

# 1 INTRODUCTORY PROVISIONS

<b>1.1</b>	<b>GENERAL.....</b>	<b>3</b>
	Title	3
	Authority	3
	Applicability	3
	Intent	3
	Regulatory Scope	4
	Compliance	4
	Fines and Penalties	4
	Conflicting Provisions	4
	Meaning & Intent	4
	Text & Graphics	5
	Severability & Invalidity	5
<b>1.2</b>	<b>ADOPTION &amp; EFFECT .....</b>	<b>5</b>
	Adoption Date	5
	Applicability	5
	Published Notice	5
	Claim of Invalidity	5
<b>1.3</b>	<b>OFFICIAL MAPS .....</b>	<b>6</b>
	Zoning Atlas	6
	Zoning Districts Map	6
	Transit Areas Map	6
	Pedestrian Streets Map	6



## 1.1 GENERAL

### 1. Title

- a. This Ordinance is known as the ‘Zoning Ordinance of the City of Somerville’ and may also be cited and referred to as ‘Somerville Zoning Ordinance’ and ‘SZO’.

### 2. Authority

- a. This Ordinance is adopted under the authority granted by Article 89 of the Amendments to the Constitution of the Commonwealth of Massachusetts and enacted in accordance with the provisions of the Massachusetts General Laws (M.G.L.) Chapter 40A, as amended.

### 3. Applicability

- a. Unless otherwise specified, this Ordinance is applicable to all real property within the City of Somerville except as follows:
  - i. Real property USED or occupied by the City of Somerville is exempt from the provisions of this Ordinance.
  - ii. Real property USED or occupied by the Commonwealth of Massachusetts in conducting its essential government functions is exempt from the provisions of this Ordinance.
- b. All divisions, departments, commissions, boards, and authorities of the City of Somerville shall comply with the procedural requirements of this Ordinance.

### 4. Intent

- a. Plan Implementation
  - i. To implement the COMPREHENSIVE PLAN of the City of Somerville and enforce officially adopted plans and policies.
  - ii. To permit DEVELOPMENT and REDEVELOPMENT according to plans that are collaboratively developed with the Somerville community.
- b. Regulatory Context
  - i. To equitably balance the regulation of real property with the interests of the community as a whole.
  - ii. To protect the health, safety, and general welfare.
- c. Land DEVELOPMENT Pattern
  - i. To ensure the DEVELOPMENT of a well-connected THOROUGHFARE network, composed of direct and convenient routes that reinforce Somerville as a walkable, human-scaled urban environment.
  - ii. To ensure that the limited land area of Somerville is efficiently divided into a BLOCK and LOT pattern consistent with the COMPREHENSIVE PLAN of the City of Somerville.
  - iii. To preserve and expand the city’s walkable network of human scaled THOROUGHFARES and the small BLOCK and LOT pattern of land division.
  - iv. To protect the social, environmental, and economic

benefits provided by a walkable DEVELOPMENT pattern.

- v. To discourage THOROUGHFARES and intersections that limit connectivity, discourage walking, induce traffic congestion, and increase vehicular air pollutant emissions by reducing the number of possible routes of travel and adding unnecessary distance between destinations.
  - vi. To require ALLEY-loaded BLOCKS that concentrate “back-of-house” elements such as utility INFRASTRUCTURE, refuse collection, and ACCESS to parking and loading in the BLOCK interior, to the rear of buildings.
  - vii. To require the platting of land so that LOTS have frontage upon and buildings are properly oriented toward the PUBLIC REALM of an ABUTTING THOROUGHFARE OR CIVIC SPACE.
- d. Neighborhoods
    - i. To develop and maintain complete, mixed-USE, walkable, transit-oriented, and environmentally sustainable neighborhoods that foster a strong sense of community throughout the city.
    - ii. To provide distinct physical habitats at different scales, including the LOT, BLOCK, and neighborhood, so that meaningful choices in living arrangement can be provided to residents with differing physical, social, and emotional needs.
    - iii. To provide a range of housing types, unit sizes, and price points to accommodate the diverse household sizes and life stages of Somerville residents at all income levels,
    - iv. To provide and protect housing that is affordable to households with low and moderate incomes.
    - v. To preserve and enhance the existing character of Somerville’s traditional housing and respect existing built form and DEVELOPMENT patterns.
  - e. PUBLIC REALM
    - i. To resolve design conflicts between vehicular and pedestrian movement in favor of the pedestrian.
    - ii. To preserve and enhance the design of Somerville’s PUBLIC REALM.
  - f. CIVIC SPACE
    - i. To ensure a variety of functional, well-designed civic and recreation spaces that complement the character of adjacent properties, contribute to a comprehensive OPEN SPACE network, and increase the livability of the city.
  - g. Transportation
    - i. To develop a comprehensive network of THOROUGHFARES that accommodate multiple modes of transportation, organized in a hierarchy defined by the character of each type.
  - h. Parking & Mobility
    - i. To ensure that off-STREET ACCESSORY parking for motor

# 1. INTRODUCTORY PROVISIONS

## General

vehicles is provided in a manner consistent with the objectives and policies of the COMPREHENSIVE PLAN of the City of Somerville.

- ii. To establish parking policies that support transit-oriented DEVELOPMENT and a walkable, human-scaled urban environment.
  - iii. To un-bundle the cost of off-STREET parking from the cost of housing, so that housing in Somerville is more affordable.
  - iv. To encourage the USE of public transportation, bicycling, and walking in lieu of motor vehicle USE when a choice of travel mode exists.
  - v. To allow flexibility in how parking is provided by allowing shared and/or off-SITE arrangements in order to accommodate the parking of motor vehicles in a manner that is less disruptive to the urban environment.
  - vi. To balance the supply of off-STREET parking with local THOROUGHFARE network capacity.
- i. Buildings
    - i. To require a strong connection and gradual transition between the PUBLIC REALM (sidewalks, THOROUGHFARES, and CIVIC SPACES) and private realm (yards and building interiors).
    - ii. To promote the adaptation of existing buildings and permit REDEVELOPMENT and infill construction that contributes to Somerville’s architectural legacy, while respecting neighborhood character.
  - j. Economic DEVELOPMENT
    - i. To increase commercial tax base in support of the fiscal health of the City.
    - ii. To permit the activities customary to daily life within walking distance of most dwellings, providing ACCESSIBILITY to goods and services for all residents of Somerville including the disabled, elderly, young, low income, and those that do not drive or choose not to own an automobile.
    - iii. To protect and promote a diverse mix of businesses.
    - iv. To increase ACCESSIBILITY to diverse employment opportunities within Somerville.
    - v. To provide opportunities for businesses to remain in Somerville as they develop and grow.
    - vi. To capture a fiscal return on investments made in transportation infrastructure by locating higher intensity DEVELOPMENT, employment opportunities, and a broad mix of USES along major corridors and within walking distance of transit stops.

### 5. Regulatory Scope

- a. The provisions of this Ordinance are the minimum necessary to achieve the stated purposes.

### 6. Compliance

- a. No real property may be occupied or USED; no USE of an existing building or land may change; no SIGN may be ERECTED, replaced, altered, refurbished, or otherwise modified; and no building or STRUCTURE may be constructed, reconstructed, altered, expanded, or enlarged in whole or in part for any purpose except as specifically authorized by this Ordinance.
- b. This Ordinance does not restrict the USE of land or STRUCTURES for activities protected by M.G.L. Chapter 40A, Section 3.

### 7. Fines and Penalties

- a. The BUILDING OFFICIAL shall fine any person who violates the provisions of this Ordinance three hundred dollars (\$300.00) for each offense, where each day that a violation is not corrected or abated constitutes a separate offense.
- b. In addition to procedure for enforcement described above, the BUILDING OFFICIAL may enforce the ordinance by a non-criminal disposition per MGL 4021d.

### 8. Conflicting Provisions

- a. This Ordinance does not abrogate, annul, or otherwise interfere with any EASEMENT, covenant, and/or other private agreements.
- b. Where the provisions of this Ordinance impose a greater restriction than required by other ordinances, regulations, resolutions, rules, EASEMENTS, covenants, or agreements, the provisions of this Ordinance apply.
- c. All DEVELOPMENT activity must comply with relevant Federal and State law and regulations. Where the provisions of this Ordinance imposes a greater restriction than required by Federal or State law, the provisions of this Ordinance apply unless otherwise prohibited by law.

### 9. Meaning & Intent

- a. Words, phrases, and terms USED in this Ordinance are defined in Article 2: Glossary & Overview .
- b. Words, phrases, and terms not defined in Article 2: Glossary & Overview are subject to the definitions of the Commonwealth of Massachusetts State Building Code (780 CMR).
- c. Words, phrases, and terms not defined by either Article 2: Glossary & Overview or the Commonwealth of Massachusetts State Building Code are defined by the most recent edition of Webster’s Unabridged Dictionary.
- d. Words used or defined in one tense or form include other tenses and derivative forms.
- e. Words in the singular or plural include the other, unless



# 1. INTRODUCTORY PROVISIONS

Adoption & Effect

expressly excluded.

- f. Words in the masculine or feminine include the other.
- g. The words 'must', 'shall', 'will', and 'may not' are mandatory.
- h. The words 'may' and 'should' are permissive.
- i. The words building, BUILDING TYPE, land, LOT, PARCEL, premises, SITE, STRUCTURE, and THOROUGHFARE are construed as though followed by the words 'or any portion thereof'.
- j. The words 'USED' or 'occupied' include designed, arranged, intended, or offered for USE or OCCUPATION.
- k. The terms 'standards', 'regulations', and 'requirements' are USED to mandate a specific course of action or built outcome. Compliance with standards, regulations, and requirements is mandatory and indicated by USE of the terms 'must', 'shall', 'will', 'may,' and 'may not'.
- l. The term 'guideline' is USED for actions or built outcomes that are strongly encouraged to fulfill the intent of specific sections of this Ordinance. Guidelines are indicated by USE of the term 'should'.
- m. Unless otherwise specifically indicated, lists of items or examples that USE terms such as 'for example', 'including', and 'such as', or similar language, are intended to provide examples and not as exhaustive lists of all possibilities.

## 10. Text & Graphics

- a. Figures and photos are intended only for illustrative purposes and to help illustrate the intent and requirements of the text. In the case of a conflict between the text of this Ordinance and any figure or photos, the text governs.
- b. Photographs provided in the Ordinance have no regulatory purpose and are intended only as examples.

## 11. Severability & Invalidity

- a. If any provision of this Ordinance or the application of any provision to real property, APPLICANT, or PROPERTY OWNER is declared unconstitutional or otherwise held invalid, the remaining provisions of this Ordinance and their application to any other real property, APPLICANT, or PROPERTY OWNER remains valid.

## 1.2 ADOPTION & EFFECT

### 1. Adoption Date

- a. This Ordinance was adopted by the Somerville City Council on Month, XX, 201X and supersedes the Zoning Ordinance of the City of Somerville adopted on March, 23, 1990, as amended.

### 2. Applicability

- a. This Ordinance is applicable on the date it is adopted.
- b. Amendments to this Ordinance are applicable on the date first publicly noticed in accordance with M.G.L. 40A.
- c. All discretionary and administrative permits, excluding Site Plan Approval, issued prior to the applicability dates of §1.2.2.a and §1.2.2.b remain valid, subject to the conditions of the permit(s), in accordance with M.G.L. 40A.

### 3. Published Notice

- a. Per M.G.L. 40 Section 32, notice of the adoption of this Ordinance, or any amendment to this Ordinance, must be published at least two (2) times in a newspaper of general circulation without delay upon its adoption by the City Council and signing into law by the Mayor. Failure to publish this notice does not affect the validity of this Ordinance or its amendments.

### 4. Claim of Invalidity

- a. No claim of invalidity of this Ordinance may be made in any legal proceeding after ninety (90) days have passed following the publication of notice of adoption.
- b. Appellants shall provide notice specifying the COURT, parties, claim of invalidity, and date of filing to the Office of the City Clerk within seven (7) days after commencement of such action.

# 1. INTRODUCTORY PROVISIONS

## Official Maps

### 1.3 OFFICIAL MAPS

#### 1. Zoning Atlas

- a. Zoning district boundaries and sub-district designations are shown on maps of the “Official Zoning Atlas of the City of Somerville”
- b. This atlas and its maps may be cited and referred to as the “Official Zoning Atlas”
- c. The Planning Director shall maintain the Official Zoning Atlas in accordance with the most recent zoning map amendment approved by the City Council.
- d. The Official Zoning Atlas may be supplemented by additional layers or separate maps to the atlas sheets when the scale of the atlas sheets do not adequately illustrate the details of boundaries or designations of a particular area.

#### 2. Zoning Districts Map

- a. Establishment of Districts
  - i. Zoning districts are established as described in this Ordinance and applied to real property as shown on the maps of the Official Zoning Atlas or on maps included within the text of this Ordinance.
- b. Boundaries
  - i. Zoning district boundary lines are intended to follow LOT LINES, or be parallel or perpendicular to them, and along the centerlines of private rights-of-way, public ALLEYS, and railroad rights-of-way as indicated on the maps of the Official Zoning Atlas.
  - ii. Where the maps of the Official Zoning Atlas indicate a district boundary line that approximately coincides with a LOT LINE, the LOT LINE is the official boundary between districts.
  - iii. Where the maps of the Official Zoning Atlas indicate a district boundary line that divides a platted LOT or undivided PARCEL of land, the boundary between districts is determined using the scale of that map in the Official Zoning Atlas and the provisions for each zoning district apply to the portion of the LOT within the respective districts.
- c. Unmapped Land
  - i. Any THOROUGHFARE that is decommissioned may be USED or developed as if it is incorporated into the adjacent zoning district.
  - ii. Any land not specifically included in any zoning district on the maps of the Official Zoning Atlas is subject to the provisions of Article 11: PUBLIC REALM Standards and classified as the Civic district unless rezoned according to the Map Amendment procedures of Article 15: Administration.

#### 3. Transit Areas Map

- a. TRANSIT STATIONS and all LOTS located within one-quarter (1/4) and one-half (1/2) mile walking distance to each station are shown on the “Official TRANSIT AREA Map of the City of Somerville”
- b. This map may be cited and referred to as the “TRANSIT AREA Map”
- c. The TRANSIT AREA Map is part of the Official Zoning Atlas as established in §1.C.1. Zoning Atlas.

#### 4. Pedestrian Streets Map

- a. PEDESTRIAN STREETS are shown on the “Official PEDESTRIAN STREETS Map of the City of Somerville”
- b. This map may be cited and referred to as the “PEDESTRIAN STREETS Map”
- c. The PEDESTRIAN STREETS Map is part of the Official Zoning Atlas as established in §1.C.1. Zoning Atlas.
- d. A PEDESTRIAN STREET designation is intended to include the entirety of each designated BLOCK FACE. Where the PEDESTRIAN STREETS Map indicates a designation that identifies only part of BLOCK FACE, the length of the designation is one hundred (100) feet of the FRONT LOT LINE or combination of FRONT LOT LINES extending from the corner of the BLOCK.

# 1 GLOSSARY & OVERVIEW

<b>1.1</b>	<b>GLOSSARY .....</b>	<b>9</b>
	General	9
<b>1.2</b>	<b>ZONING ATLAS OVERVIEW .....</b>	<b>22</b>
	Zoning Districts	22
	Transit Areas	23
	Pedestrian Streets	23
<b>1.3</b>	<b>BUILDING TYPES OVERVIEW .....</b>	<b>24</b>
	General	24
	Building Assembly	24
	Understanding the Building Type Pages	25
<b>1.4</b>	<b>STANDARDS &amp; MEASUREMENTS .....</b>	<b>26</b>
	General	26
	Lot Standards	26
	Building Placement	26
	Massing & Height	28
	Uses and Features	30
	Building Components	32



### 2.1 GLOSSARY

#### 1. General

- a. The following words, phrases, and terms identified by capitalized lowercase typeface in this Ordinance are defined in this Section.

<b>100% Affordable Housing</b>	Any building that is deed restricted so that all dwelling units are rented or sold to households with incomes at or below one hundred and twenty percent (120%) of the Median Family Income for the Boston-Cambridge-Quincy, MA-NH HUD Metro FMR Area.
<b>Abut or Abutting</b>	To physically touch or share a contiguous boundary or border, such as a common lot line, or to be separated only by an alley or shared driveway.
<b>Access</b>	The way or means to enter and leave.
<b>Accessory Building</b>	A building or structure designed, used, or occupied in relation to the principal use(s) of a given lot.
<b>Accessory Use</b>	A use(s) of a lot, structure or portion thereof that is incidental and related to a principal building or use of land and located on the same lot as the principal building or use of land.
<b>Affordable Dwelling Unit</b>	A dwelling unit sold, leased, or rented at a price affordable to a specific household income. Affordable dwelling unit is abbreviated as ADU. (See Article 12)
<b>Affordable Dwelling Unit, Existing</b>	An ADU subject to a covenant or deed restriction limiting its sale, lease, or rental. Existing affordable dwelling unit is abbreviated as Existing-ADU. (See Article 12)
<b>Albedo</b>	The amount of solar radiation reflected by a surface.
<b>Alcohol Sales</b>	A specific use type of the Consumer Goods principal use category. See §9.2.12.c.i Alcohol Sales.
<b>Allee</b>	Objects placed in a straight line.
<b>Alley</b>	A thoroughfare, located within a block and providing access to the rear of buildings, loading facilities, service areas, trash storage, motor vehicle parking, and usually containing easements for dry utilities.
<b>Amenity Space</b>	A feature of a lot or building that provides outdoor social, recreational, and/or leisure space for the comfort and/or convenience of the residents of a building.
<b>Amenity Space, Private</b>	Features of a building and outdoor areas designed for the comfort and convenience of residents.
<b>Amenity Space, Shared</b>	Rooms and facilities designed for the comfort and convenience of residents of a multi-unit building.
<b>Ancillary</b>	Providing necessary support for the operation of a principal use.
<b>Animal Services</b>	A Commercial Services principal use category. See §9.2.6.a Animal Services.
<b>Antenna</b>	Equipment for wireless communication, including but not limited to panel antennas, whip antennas, and satellite dishes that may be freestanding, mounted inside a structure (such as a steeple, belfry, cupola, or other tower or rooftop element), or side-mounted to the face of a building, penthouse, smokestack, or chimney, to conceal its presence and reduce its visual impact.
<b>Apiculture</b>	A specific use type of the Urban Agriculture accessory use category. See §9.2.14.d.i Apiculture.
<b>Applicant</b>	A person or entity who has submitted a development review application under applicable provisions of this Ordinance; a petitioner in accordance with M.G.L. 40A; the legal or beneficial owner(s) of a lot or land included in a proposed development, including the holder of an option or contract to purchase, or any other person having an enforceable proprietary interest in such land.
<b>Aquaculture</b>	The farming of aquatic organisms such as fish, crustaceans, molluscs, and aquatic plants.

## 2. GLOSSARY & OVERVIEW

### Glossary

<b>Aquaponics</b>	The production of food using conventional aquaculture with hydroponics in a symbiotic environment.
<b>Arbor</b>	A structure with an open frame, freestanding or attached to another structure, with horizontal or vertical latticework often used as a support for ornamental vines and/or climbing plants.
<b>Architectural Bay</b>	The vertically oriented area of a facade between two piers, pilasters, columns, curtain wall mullions, spandrel glass, or other equivalent architectural features.
<b>Articulate</b>	To form or have a joint.
<b>Articulated/Articulation</b>	Two or more surfaces connected by a joint.
<b>Articulation</b>	The state of being jointed.
<b>Artisinal Production</b>	An Arts & Creative Enterprise principal use category. See §9.2.2.a Artisinal Production.
<b>Arts Center</b>	A multi-purpose facility dedicated to the expansion and practice of the arts by providing recourses such as theatre space, gallery space, musical performance venues, workshop areas, educational facilities, or access to equipment to members of the community.
<b>Arts Exhibition</b>	An Arts & Creative Enterprise principal use category. See §9.2.2.b Arts Exhibition.
<b>Arts Sales or Services</b>	An Arts & Creative Enterprise principal use category. See §9.2.2.c Art Sales & Services.
<b>Assembly or Entertainment</b>	A Commercial Services principal use category. See §9.2.6.b Assembly or Entertainment.
<b>Assembly Square Plan</b>	The following documents, as amended, constitute the Assembly Square Plan: <ol style="list-style-type: none"><li>1. Assembly Square Planning Study: A Vision and Implementation Plan for the Future, prepared for the Somerville Office of Housing and Community Development (OHCD), dated October 2000;</li><li>2. Assembly Square Revitalization Plan: 2002 Major Plan Change, prepared by the Somerville OHCD, dated May 2002;</li><li>3. Assembly Square: Design Guidelines for the Public Realm, prepared for the Somerville OHCD, dated March 2002;</li><li>4. Assembly Square Transportation Plan (ASTP), prepared for the Somerville OHCD in conjunction with the Commonwealth of Massachusetts Highway Department and the Executive Office of Transportation and Construction, dated May 2003.</li></ol>
<b>Automatic Sprinkler System</b>	As defined by the MA State Building Code.
<b>Average Daily Trips</b>	The number of vehicles passing a point on a traffic way during a 24-hour period, usually calculated as the average of two (2) or more measured days of traffic. Average daily trips is abbreviated as ADT.
<b>Average Grade</b>	The mean (average) of the finished ground level of a civic space at the corners of the lot.
<b>Average Ground Level</b>	The mean (average) of the finished ground level next to a building at the exterior walls.
<b>Aviculture</b>	A specific use type of the Urban Agriculture accessory use category. See §9.2.14.d.ii Aviculture.
<b>Banking or Financial Services</b>	A Commercial Services principal use category. See §9.2.6.c Banking & Financial Services.
<b>Bakery, Cafe, or Coffee Shop</b>	A Food or Beverage Service principal use category. See §9.2.7.a Bakery, Cafe, or Coffee Shop.
<b>Bar, Restaurant, or Tavern</b>	A Food or Beverage Service principal use category. See §9.2.7.a Bar, Restaurant, or Tavern.
<b>Basement</b>	Any story, in whole or in part, below the ground story of a building.
<b>Bed &amp; Breakfast</b>	A Lodging principal use category. See §9.2.9.a Bed & Breakfast.

## 2. GLOSSARY & OVERVIEW

### Glossary

<b>Bedroom</b>	A private room for sleeping, however named, planned, intended or used, which is separated and can be closed off from other parts of the dwelling by walls and a door.
<b>Bicycle Parking, Long-Term</b>	Accommodations for the parking of a bicycle for two (2) or more hours.
<b>Bicycle Parking, Short-Term</b>	Accommodations for the parking of a bicycle for two (2) hours or less.
<b>Bike-Share Parking</b>	A specific use type of the Vehicle Parking principal use category. See §9.2.6.m.i Bike-Share Parking.
<b>Blank Wall</b>	A portion of any facade of a building that does not include a substantial material change; windows, doors, columns, pilasters or other articulation.
<b>Block</b>	The aggregate land area circumscribed by thoroughfares or other rights-of-way.
<b>Block Face</b>	The aggregate of all front lot lines, and alleys, if present, on one side of a block.
<b>Body Art Services</b>	A specific use type of the Personal Services principal use category. See §9.2.6.k.i Body Art Services.
<b>Broadcast or Recording Studio</b>	A Commercial Services principal use category. See §9.2.6.d Broadcast or Recording Studio.
<b>Building</b>	Any structure, either temporary or permanent, having a roof or other covering, and designed or used for the shelter or enclosure of any person, animal, or property of any kind, including tents, awnings, or vehicles situated on private property and used for purposes of a building.
<b>Building or Home Supplies or Equipment</b>	A Retail Sales principal use category. See §9.2.12.a Building or Home Supplies or Equipment.
<b>Building or Home Repair Services</b>	A Commercial Services principal use category. See §9.2.6.e Building or Home Repair Services.
<b>Building Components</b>	Accessory features that increase the habitable square footage or enhance the usefulness of a building.
<b>Building Official</b>	The Superintendent of Inspectional Services, Senior Building Inspector, Local Building Inspector, Zoning Review Planner, or other person designated to enforce this Ordinance.
<b>Business Support Services</b>	A Commercial Services principal use category. See §9.2.6.f Business Support Services.
<b>Building Type</b>	A classification or kind of structure characterized and differentiated by its placement on a lot, massing, composition, use, and features.
<b>By Right</b>	Uses and structures that are permitted in a zoning district.
<b>Caliper</b>	A measurement of the diameter of a tree trunk. For trees less than four (4) inches in diameter, caliper is measured six (6) inches from the ground. For trees between four (4) inches and twelve (12) inches in diameter, caliper is measured twelve (12) inches from the ground.
<b>Cannabis Cultivation</b>	A Cannabis Enterprise principal use category. See §9.2.4.b Cannabis Cultivation.
<b>Cannabis Product Manufacturing</b>	A Cannabis Enterprise principal use category. See §9.2.4.c Cannabis Product Manufacturing.
<b>Cannabis Retail Sales</b>	A Cannabis Enterprise principal use category. See §9.2.4.d Cannabis Cultivation.
<b>Cannabis Research &amp; Development</b>	A Cannabis Enterprise principal use category. See §9.2.4.e Cannabis Research & Development.
<b>Cannabis Testing Laboratory</b>	A Cannabis Enterprise principal use category. See §9.2.4.f Cannabis Testing Laboratory.
<b>Carport</b>	A roofed structure, unenclosed on two (2) or more sides, used or designed for the off-street parking of motor vehicles.
<b>Car-Share Parking</b>	A specific use type of the Vehicle Parking principal use category. See §9.2.6.m.ii Car-Share Parking.
<b>Caterer or Wholesale Food Production</b>	A Commercial Services principal use category. See §9.2.6.g Caterer or Wholesale Food Production.

## 2. GLOSSARY & OVERVIEW

### Glossary

<b>Change in Use</b>	A change in the use of real property, whether temporary or permanent, from one use category to a different use category as defined by Article 9. Use Provisions.
<b>Chicken</b>	A common domestic chicken ( <i>Gallus gallus domesticus</i> ).
<b>Civic Space</b>	An open space designed to support civic, cultural, ecological, recreational, or social activities. Civic space types are defined by a combination of characteristics, including the interrelationship between the intended uses, size, landscape design, and abutting real property.
<b>Cladding</b>	The exterior material that covers or overlays another material or structure.
<b>Clearance</b>	The height above the sidewalk or other surface, as specified, of the bottom edge of an object or building component.
<b>Co-Working Commercial</b>	An Arts & Creative Enterprise principal use category. See §9.2.2.d Co-Working.
<b>Commercial Farming</b>	A term collectively defining permitted uses from all non-residential use categories, excluding parking.
<b>Commercial Farming</b>	A specific use type of the Farming principal use category (See §9.2.13.a.i Commercial Farming) and a specific use type of the Urban Agriculture accessory use category (See §9.2.14.d.iii Commercial Farming).
<b>Commercial Parking</b>	A specific use type of the Vehicle Parking principal use category. See §9.2.6.m.iii Commercial Parking.
<b>Vehicle Repair &amp; Maintenance</b>	An Auto-Oriented principal use category. See §9.2.3.a Vehicle Repair or Maintenance.
<b>Community Center</b>	A Civic & Institutional principal use category. See §9.2.5.a Community Center.
<b>Community Farming</b>	A specific use type of the Farming principal use category. See §9.2.13.a.ii Community Farming.
<b>Community Gardening</b>	An Urban Agriculture principal use category. See §9.2.13.b Community Gardening.
<b>Comprehensive Plan</b>	The City of Somerville's official plan providing guidance and direction for future decision making that affects local government policy and community development as approved by the Planning Board per M.G.L. 41, 81d.
<b>Consumer Goods</b>	A Retail Sales principal use category. See §9.2.12.b Consumer Goods.
<b>Corner Board</b>	Flat vertical exterior casings framing siding or shingles at inside and outside corners.
<b>Cornice</b>	The molded and projecting horizontal member that crowns an architectural composition.
<b>Community or Group Residence</b>	A specific use type of the Group Living principal use category. See §9.2.11.b.i Community or Group Residence.
<b>Cost Burden</b>	When a household pays more than thirty percent (30%) of its income for housing.
<b>Cost Burden, Severe</b>	When a household pays more than fifty percent (50%) of its income for housing.
<b>Court</b>	An open, uncovered space, unobstructed to the sky, bounded on three or more sides by exterior building walls or other enclosing devices.
<b>Creative Incubator</b>	An organization providing startup and early-stage arts and creative enterprises with shared facilities and often providing business planning, access to finance, mentoring, and other business or administrative support services.
<b>Creative Studio</b>	A specific use type of the Home Occupation accessory use category. See §9.2.14.c.ii Creative Studio.
<b>Culinary Incubator</b>	An organization providing start-up catering, retail, and wholesale food businesses with shared kitchen facilities and often providing business planning, access to finance, mentoring, and other business or administrative support services.
<b>Cultivar</b>	A cultivated variety of tree; deliberately selected for its desirable physical characteristics.
<b>Curb Cut</b>	A section of sidewalk curbing removed to facilitate vehicular access to a driveway or vehicular entrance to a parking structure.
<b>Data Center</b>	An Industrial principal use category. See §9.2.8.b Data Center.



## 2. GLOSSARY & OVERVIEW

### Glossary

<b>Day Care Center, Adult</b>	A specific use type of the Day Care Services principal use category. See §9.2.6.h.i Adult Day Care Center.
<b>Day Care Center, Child</b>	A specific use type of the Commercial Services principal use category. See §9.2.6.h.ii Child Day Care Center.
<b>Day Care Services Deck</b>	A Commercial Services principal use category. See §9.2.6.h Day Care Services. A roofless, raised platform accessible from a secondary entrance to a building that provides outdoor amenity space.
<b>Demolition</b>	The destruction or removal of fifty percent (50%) or more of the surface area of the exterior walls and roof of a building or any exploratory demolition or internal demolition that compromises the structural integrity of a building. Normal maintenance is not demolition.
<b>Demolition, Exploratory</b>	The removal of non-structural interior building materials prior to renovation, rehabilitation, restoration, or remodeling in order to verify the existing conditions present in otherwise unexposed areas.
<b>Demolition, Internal</b>	The removal of non-structural interior building materials for the purpose of renovating, rehabilitating, restoring, or remodeling interior space.
<b>Design &amp; Fabrication Center</b>	A facility providing individuals and small firms access to professional manufacturing tools & equipment; classes & training; lab, workshop, and studio space; and storage for tools and supplies.
<b>Design Services</b>	An Arts & Creative Enterprise principal use category. See §9.2.2.e Design Services.
<b>Desire Line Development</b>	A route that pedestrians prefer to take to get from one location to another. The construction or modification of any principal building type, accessory building type, or other structure; the excavation, fill, or grading of land; and the establishment, change, or expansion of any use of any structure or land.
<b>Development Site</b>	The land area encompassed in a development proposal irrespective of the number or configuration of lots, land ownership, or municipal boundaries.
<b>Diameter at Breast Height</b>	The diameter of a tree trunk or the square root of the sum of each trunk squared for a multi trunk tree, measured four and one-half (4.5) feet above ground. Diameter at breast height is abbreviated as DBH.
<b>Dispatch Service</b>	An Auto-Oriented principal use category. See §9.2.3.b Dispatch Services.
<b>Driveway Apron</b>	A ramp that slopes down from the edge of the walkway of a sidewalk to the roadway surface of an abutting thoroughfare.
<b>Dry Cleaning or Laundry Services</b>	An Industrial principal use category. See §9.2.8.a Dry Cleaning or Laundry Services.
<b>Dormitory or Chapter House</b>	A specific use type of the Group Living principal use category. See §9.2.11.b.ii Dormitory or Chapter House.
<b>Dwelling Unit</b>	One (1) or more rooms providing separate, independent living space with lawful cooking and sanitary facilities for the exclusive use of the occupants.
<b>Easement</b>	A liberty, privilege, or advantage without profit, which a person(s) may have in the lands of another person(s).
<b>Educational Services</b>	A Commercial Services principal use category. See §9.2.6.i Educational Services.
<b>Employer Encroach</b>	A person or business that employs one (1) or more people for wages or salary. To break the plane of a vertical or horizontal regulatory limit with a structural element, so that it extends into a setback or over the sidewalk of a public right-of-way.
<b>Encroachment Erect</b>	Any structural element that encroaches. To construct, reconstruct, excavate, fill, drain, or conduct physical operations of any kind in preparation for or in pursuance of construction or reconstruction, or to move a building or structure upon a lot.
<b>Fabrication Laboratory</b>	A high-tech workshop that fosters innovation and invention by providing individuals with access to tools and machinery for “do-it-yourself” (DIY) digital

## 2. GLOSSARY & OVERVIEW

### Glossary

	fabrication.
<b>Facade</b>	Any exterior wall of a building oriented in whole or in part toward a front lot line, or civic space, excluding the exterior walls of any roof elements.
<b>Farm or Vendor Market</b>	A Retail Sales principal use category. See §9.2.12.e Farm or Vendor Market.
<b>Farming</b>	An Urban Agriculture principal use category. See §9.2.13.a Farming.
<b>Farm Stand</b>	A temporary structure for the display and sale of clean, whole, unprocessed produce, eggs, or honey cultivated on site.
<b>Fenestration</b>	The openings in the facade of a building, including windows and doors.
<b>Firearms Sales</b>	A specific use type of the Consumer Goods principal use category. See §9.2.12.c.ii Firearms Sales.
<b>Floor Area, Gross</b>	The sum floor area of a building, in whole or on part, as measured to the face of the exterior walls, with no deduction for corridors, stairs, closets, thickness of walls, columns, or other features.
<b>Floor Area, Leasable</b>	The floor area included in a commercial lease.
<b>Floor Area, Net</b>	The sum floor area of a building, in whole or on part, measured to the face of the interior walls.
<b>Floor Plate</b>	The total gross floor area of a single story of a building, excluding balconies.
<b>Forecourt</b>	An open space formed by a substantial recess in the central portion of a building's facade.
<b>Formula Food or Beverage Service</b>	A Food or Beverage Service principal use category. See §9.2.7.c Formula Food or Beverage Service.
<b>Formula Retail</b>	A Retail Sales principal use category. See §9.2.12.c Formula Retail.
<b>Fresh Food Market or Grocery Store</b>	A Retail Sales principal use category. See §9.2.12.d Fresh Food Market or Grocery Store.
<b>Frontage Area</b>	The area of a lot between the facade of a principal building and any front lot line(s), extending fully to each side lot line(s).
<b>Funeral Services</b>	A specific use type of the Personal Services principal use category. See §9.2.6.k.iii Funeral Services.
<b>Furniture Area</b>	An area of an amenity space that allows for the placement of furniture without restricting the movement of pedestrians.
<b>Gasoline Station</b>	An Auto-Oriented principal use category. See §9.2.3.c Gasoline Station.
<b>General Office</b>	An Office principal use category. See §9.2.10.a General Office.
<b>Green Score</b>	An performance-based environmental landscape standard measured as a ratio of the weighted value of all landscape elements to the total land area (in square feet) of a lot. See Section 10.4 Green Score for more information.
<b>Group Living</b>	A Residential principal use category. See §9.2.11.b Group Living.
<b>Health or Fitness Services</b>	A specific use type of the Personal Services principal use category. See §9.2.6.k.ii Health or Fitness Services.
<b>Habitable</b>	Spaces in a building for living, sleeping, eating or cooking. Bathrooms, toilet rooms, closets, halls, storage or utility spaces and similar areas are not considered habitable spaces.
<b>Heat Island</b>	The higher average air temperatures of the local micro-climate due to the absorption, retention, and generation of heat by buildings, pavements, and human activities.
<b>Hen</b>	A female domestic chicken.
<b>High-Rise</b>	Any building taller than seventy (70) feet above average ground level.
<b>Hobby Kennel</b>	A specific use type of the Home Occupation Accessory Use category. See §9.2.14.c.iii Hobby Kennel.
<b>Homeless Shelter</b>	A specific use type of the Group Living principal use category. See §9.2.11.b.iii Homeless Shelter.
<b>Home-Based Business</b>	A specific use type of the Home Occupation accessory use category. See §9.2.14.c.iv Home-Based Business.

<b>Home-Based Business Vehicle Parking</b>	A specific use type of the Vehicle Parking accessory use category. See §9.2.14.e.i Home-Based Business Vehicle Parking.
<b>Home-Based Day Care</b>	A specific use type of the Home Occupation accessory use category. See §9.2.14.c.v Home-Based Day Care.
<b>Home Office</b>	A specific use type of the Home Occupation accessory use category. See §9.2.14.c.vi Home Office.
<b>Home Occupation</b>	An accessory use category. See §9.2.14.c Home Occupation.
<b>Honeybee</b>	A common domestic honeybee ( <i>Apis mellifera</i> ).
<b>Hospital</b>	A Civic & Institutional principal use category. See §9.2.5.b Hospital.
<b>Hotel or Hostel</b>	A Lodging principal use category. See §9.2.9.b Hotel or Hostel.
<b>Household Living</b>	A Residential principal use category. See §9.2.11.a Household Living.
<b>Hydroculture</b>	The growing of plants in a soilless medium or an aquatic based environment.
<b>Hydroponics</b>	A method of growing plants using a mineral-nutrient solution, without soil.
<b>Junk</b>	Any discarded article or material, including unregistered motor vehicles, which is ready for destruction or has been collected or stored for salvage or conversion to some use.
<b>Lamp</b>	The source of illumination in a lighting fixture.
<b>Land Conveyance</b>	The transfer of legal title of real property from one person to another.
<b>Landscape Area</b>	The area of a lot covered by turf and other Groundcovers; planting beds; permeable, pervious, or porous pavements; and inorganic surfacing such as stone, gravel, and and other similar materials.
<b>Large Tree</b>	A woody plant with an expected mature height of thirty (30) feet or more.
<b>Library</b>	A Civic & Institutional principal use category. See §9.2.5.c Library.
<b>Light Source</b>	The lamp and all refractive, reflective, and translucent light transmitting parts of an outdoor light fixture.
<b>Local Historic District</b>	Real property designated by the City Council as historically or architecturally significant in accordance with the Historic Districts Ordinance of the City of Somerville. Local historic district is abbreviated as LHD.
<b>Lot</b>	A bounded area of land undivided by a thoroughfare intended for use, sale, legacy, or development at any time.
<b>Lot Area</b>	The horizontal measurement of a lot in square feet, exclusive of any area in a private way that is open to public use.
<b>Lot, Corner</b>	A lot fronting two (2) or more thoroughfares at their intersection.
<b>Lot Depth</b>	The horizontal distance from the midpoint of the front lot line to the midpoint of the rear lot line of a lot or to the most distant point on any other lot line where there is no rear lot line.
<b>Lot, Flag</b>	A lot in the approximate configuration of a flag pole or sign post, with the pole or post functioning primarily as an access way to the main area of the lot from the thoroughfare providing access.
<b>Lot, Interior</b>	A lot fronting one thoroughfare and abutting other lots at both sides.
<b>Lot, Key</b>	A lot with a side lot line abutting the rear lot line of another lot.
<b>Lot, Through</b>	A lot fronting on two (2) or more thoroughfares, including parallel thoroughfares and thoroughfares that do not intersect at the boundaries of the lot.
<b>Lot Line</b>	A boundary that legally and geometrically demarcates a lot.
<b>Lot Line Adjustment</b>	Reconfiguration of the boundary line between two abutting lots, whether they are commonly owned or not, and whether the resulting shift of ground from one parcel to another is minor or substantial.
<b>Lot Line, Front</b>	Any lot line abutting a civic space or thoroughfare, excluding alleys.
<b>Lot Line, Party</b>	A side lot line shared between two attached or semi-detached Building Types.
<b>Lot Line, Primary Front</b>	Any front lot line abutting a pedestrian street.
<b>Lot Line, Rear</b>	Any lot line which is parallel to or within forty-five (45) degrees of being parallel to

## 2. GLOSSARY & OVERVIEW

### Glossary

<b>Lot Line, Side</b>	a front lot line, unless that lot line is a side lot line of an abutting lot.
<b>Lot Merger</b>	Any lot line other than a front or rear lot line. The consolidation of two (2) or more adjacent lots by eliminating the lot line that previously separated them.
<b>Lot Split</b>	The division of a lot into two (2) smaller lots.
<b>Lot Width</b>	The length of the front lot line of a lot.
<b>Lumen</b>	The unit of measure used to quantify the amount of light produced by a lamp or emitted from a luminaire (as distinct from watt, a measure of power consumption).
<b>Luminaire</b>	A light unit or fixture including any bulb(s), tube(s), housing, reflective shield, lens and/or ballast. The complete lighting unit (fixture), consisting of a lamp, or lamps and ballasts, when applicable, together with the parts designed to distribute the light (reflector, lens, diffuser), to position and protect the lamps, and to connect the lamps to the power supply.
<b>Luminaire, Fully Shielded:</b>	A luminaire constructed and installed in such a manner that all light emitted by the luminaire, either directly from the lamp or a diffusing element, or indirectly by reflection or refraction from any part of the luminaire, is projected below the horizontal plane through the luminaire's lowest light emitting part.
<b>Maintenance or Repair Services</b>	A Commercial Services principal use category. See §9.2.6.j Maintenance or Repair Services.
<b>Major Utility Facility</b>	A Civic & Institutional principal use category. See §9.2.5.e Major Utility Facility.
<b>Manufacturing</b>	An Industrial principal use category. See §9.2.8.c Manufacturing.
<b>Market Rate Unit</b>	A dwelling unit developed and sold or rented on the open market.
<b>Main Massing</b>	The primary massing of a Building Type, excluding building components.
<b>Mezzanine</b>	An intermediate floor level between the floor and ceiling of a story.
<b>Minor Utility Facility</b>	A Civic & Institutional principal use category. See §9.2.5.d Minor Utility Facility.
<b>Mobility Management</b>	A broad range of strategies intended to reduce automobile trips. The alteration of travel behavior through a program of incentives, services, and policies, including encouraging the use of alternatives to single-occupant vehicles such as public transit, cycling, walking, car-pooling/ van-pooling and changes in work schedule that move trips out of the peak period or eliminate them altogether.
<b>Mobility Management Association</b>	Organizations formed to help individual uses and property owners collectively implement and administer the Mobility Management programs and services.
<b>Motor Vehicle Parking</b>	An Auto-Oriented principal use category. See §9.2.3.d Motor Vehicle Parking.
<b>Mounting Height</b>	The height of the center of a luminaire above ground level.
<b>Moving or Storage Services</b>	An Industrial principal use category. See §9.2.8.d Moving or Storage Services.
<b>Modification</b>	Construction that alters, expands, reconstructs, extends, or structurally changes an existing structure or that changes the number of dwelling units within an existing structure.
<b>Monopole</b>	A free-standing (or wire-supported) tower for wireless telecommunications facilities.
<b>Mulch, Groundcover</b>	A protective above-ground dressing consisting of organic, non-recycled wood or bark used for moisture control, weed control, erosion control, temperature control, or other similar purposes.
<b>Museum</b>	A Civic & Institutional principal use category. See §9.2.5.f Museum.
<b>Mystic River Bank</b>	The portion of land surface abutting and confining the Mystic River, as defined by 310 CMR 10.54.2.C, as amended.
<b>Net Zero Building</b>	Any building that 1) has no on-site combustion for heating and cooking (all electric systems) and 2) has an energy use intensity that is at least twenty-five percent (25%) below ASHRAE 90.1 2010, meets the requirements of Zero Carbon Certification or higher from the International Living Future Institute, or achieves PHIUS+ Certification from the Passive House Institute US.

## 2. GLOSSARY & OVERVIEW

### Glossary

<b>Normal Maintenance</b>	Improvements intended to keep an existing structure in good physical conditions including, but not limited to, painting, roof replacement, re-siding, window replacement, and other improvements that are deemed to be cosmetic or de minimus in nature by the Building Official.
<b>Nonconformity</b>	As defined by Article 14.
<b>North-Facing</b>	Within 45 degrees of due north.
<b>Nuisance</b>	That activity which arises from unreasonable, unwarranted, or unlawful use by a person of their own property, which creates an obstruction or injury to the rights of another, or to the public, or which produces annoyance, inconvenience, disruption of work, and/or discomfort to an individual or the public.
<b>Nursing Home or Assisted Living</b>	A specific use type of the Group Living principal use category. See §9.2.11.b.iv Nursing Home or Assisted Living.
<b>Off-Site Accessory Parking</b>	A specific use type of the Motor Vehicle Parking principal use category. See §9.2.3.d.i Off-Site Accessory Parking.
<b>Open Space</b>	A ground level or upper story outdoor area including, but not limited to, natural woodlands, yards, forecourts, courtyards, green roofs and civic spaces.
<b>Outdoor Cafe Seating</b>	Outdoor seating located in a frontage or on a public sidewalk that is provided with table service.
<b>Outdoor Display</b>	The outdoor exhibition or presentation of products and merchandise available for sale.
<b>Outdoor Light Fixture</b>	Outdoor artificial illuminating devices, outdoor fixtures, lamps, and other devices, permanent or portable, used for illumination or advertisement.
<b>Outdoor Storage</b>	The storage of merchandise or material in boxes, in crates, on pallets or other kinds of shipping containers, garden supplies, building supplies, plants, vehicles, and other similar equipment, inventory, materials, merchandise, or supplies not normally brought indoors overnight.
<b>Parcel</b>	An area of land.
<b>Parking Lot</b>	An uncovered area used or designed for the off-street parking of seven (7) or more motor vehicles.
<b>Parking Stacker</b>	An automated or manually operated mechanical, multi-level lift system for storing motor vehicles vertically.
<b>Parking, Reserved</b>	A parking space for the exclusive use by a specific motor vehicle(s) and unoccupied when not in use by that specific motor vehicle(s).
<b>Parking, Shared</b>	Parking spaces shared by two (2) or more uses.
<b>Parking Space, Off-street</b>	A storage area, meeting the requirements of Article 12, located in a parking lot or driveway, for one (1) automobile, van, light truck, or other similar vehicle.
<b>Parking Space, On-street</b>	A storage area located within the street right-of-way, for one (1) parked automobile, van, light truck, or other similar vehicle.
<b>Parking Structure</b>	Any structure used or designed for the off-street parking of motor vehicles, excluding an accessory garage and carport.
<b>Party Wall</b>	A wall separating two attached buildings.
<b>Patio</b>	A hard-surfaced amenity space having no permanent roof coverings, usually directly adjacent to a building, and constructed such that its finished walking surface is laid or poured directly on finished grade.
<b>Paver</b>	A masonry block of various material or size.
<b>Pedestrian Street</b>	Any thoroughfare designated as a pedestrian street on the Pedestrian Streets Map of the Somerville Zoning Atlas.
<b>Personal Services</b>	A Commercial Services principal use category. See §9.2.6.k Personal Services.
<b>Personal Vehicle Repair or Maintenance</b>	An Auto-Oriented principal use category. See §9.2.3.e Personal Vehicle Repair or Maintenance.
<b>Pervious Area</b>	The area of a lot covered by mulch, vegetation, and permeable, pervious, or



## 2. GLOSSARY & OVERVIEW

### Glossary

<b>Pet Store</b>	porous paving or materials that reduce or eliminate the amount or rate of storm water runoff directed into the sewer or storm system. A specific use type of the Consumer Goods principal use category. See §9.2.12.c.iii Pet Store.
<b>Pier</b>	A section of a wall between fenestration.
<b>Pilaster</b>	An upright rectangular architectural member that is structurally a pier, but architecturally treated as a column, and usually projects a third of its width or less from the wall.
<b>Planter</b>	A soil area provided for the planting of street trees or other landscaping.
<b>Planting Bed</b>	A soil area planted with grass and other Groundcovers, trees, bushes, shrubs, vines, flowers, and other horticultural materials with the remaining area covered by mulch.
<b>Podium</b>	The lower portion(s) of certain high-rise buildings.
<b>Point Tower</b>	The upper stories of a high-rise building, composed of apartments surrounding a central elevator core.
<b>Principal Building</b>	A structure designed, used, or occupied for the principal use(s) of a given real property.
<b>Principal Entrance</b>	The main point of access for pedestrians into a building, upper story use, or ground story tenant space.
<b>Principal Use</b>	The main or primary purpose for which a structure, building, or lot is designed, arranged, licensed or intended.
<b>Private Non-Profit Club or Lodge</b>	A Civic & Institutional principal use category. See §9.2.5.g Private Non-Profit Club or Lodge.
<b>Property Owner</b>	An owner of land as identified on the most recent tax list maintained by the Assessor's Office of the City of Somerville.
<b>Public Realm</b>	The urban environment visible and accessible to the public, inclusive of both spaces and the building walls that frame them.
<b>Public Service</b>	A Civic & Institutional principal use category. See §9.2.5.h Public Service.
<b>Rail Right-of-Way</b>	The way for any rail service, including, but not limited to, the rail tracks, guideways, overhead power lines, and shoulder.
<b>Research &amp; Development or Laboratory</b>	An Office principal use category. See §9.2.10.b Research & Development or Laboratory.
<b>Recreation Services</b>	A Commercial Services principal use category. See §9.2.6.l Recreational Services.
<b>Recycling Collection</b>	An Industrial principal use category. See §9.2.8.e Recycling Collection.
<b>Religious &amp; Educational Uses Protected by M.G.L. 40A. Sec. 3</b>	A Civic & Institutional principal use category. See §9.2.5.i Religious & Educational Uses Protected by M.G.L. 40A. Sec. 3.
<b>Reserved Parking</b>	A parking space designed, arranged, or intended to be exclusively used or occupied by a specific motor vehicle(s) and held unoccupied when not in use by that specific motor vehicle or any parking space not made available to hourly users during the day and held unoccupied for any reason by a parking facility operator.
<b>Residential Gardening</b>	A specific use type of the Urban Agriculture accessory use category. See §9.2.14.d.iv Residential Gardening.
<b>Retaining Wall</b>	A structure designed to resist the lateral displacement of soil or other materials in order to protect property or prevent erosion.
<b>Ribbon Driveway</b>	A driveway with two parallel strips of concrete, mortar-set stone or brick, or solid or turf pavers with an open, unpaved space in between.
<b>Ribbon Windows</b>	A series of windows set side by side to form a continuous horizontal band across a facade.
<b>Roof Line</b>	The highest point on any building or structure where an exterior wall or parapet

## 2. GLOSSARY & OVERVIEW

Glossary

	wall encloses roof or floor area, including floor area provided for housing mechanical equipment.
<b>Roof, Flat</b>	A roof with no slope greater than 2:12.
<b>Roof, Gable</b>	A roof sloped on two sides from a central ridge with an exterior wall (gable) enclosing each end.
<b>Roof, Gambrel</b>	A compound, gabled roof with two slopes on each of its sides, where the lower has a steeper slope or pitch than the upper, inclusive of English, Dutch, and Jerkin Head gambrel roofs.
<b>Roof, Hip</b>	A roof with four uniformly pitched or sloping sides, inclusive of kicked hip (witch's hat) and Hawaiian hip roofs.
<b>Roof, Main</b>	The roof of the main massing of a principal building.
<b>Roof, Mansard</b>	A compound, four sided roof where each side has two slopes, where the lower has a very steep, almost vertical, slope or pitch, dormer windows, and eaves extending with a radius or kick, rather than a flat projection.
<b>Rooming House</b>	A specific use type of the Group Living principal use category. See §9.2.11.b.v Rooming House.
<b>Rooming Unit</b>	One (1) or more rooms providing separate, independent living facilities for use by one (1) or two (2) human beings living together as a single household without both lawful cooking and sanitary facilities for the exclusive use of the occupants inside the rooming unit.
<b>Salvage Yard</b>	An Industrial principal use category. See §9.2.8.f Salvage Yard.
<b>Sand-Based Structural Soil System</b>	Open graded crushed stone over sand-based structural soil.
<b>Self-Storage</b>	A specific use type of the Moving or Storage Services principal use category. See §9.2.8.d.i Self Storage.
<b>Setback</b>	A horizontal distance from a particular point of reference to the location of a principal or accessory building or an accessory structure.
<b>Shared Workspace &amp; Arts Education</b>	An Arts & Creative Enterprise principal use category. See §9.2.2.f Shared Workspace & Arts Education.
<b>Shrub</b>	A multi-stemmed, woody plant with a five-gallon container size when planted.
<b>Sign</b>	Any permanent or temporary name, identification, description, emblem, logo, structure, or device, that is illuminated or non-illuminated; visible or intended to be visible from any public place; and directs attention to a person, product, place, activity, institution, business, organization, activity, or service including any letter, numeral, character, figure, emblem, painting, illustration, banner, pennant, placard, or temporary sign designed to advertise, identify, solicit, or convey information. Signs include devices designed to attract the eye by intermittent or repeated motion and any permanently installed or situated merchandise, including any banner, pennant, placard, or temporary sign, with the exception of window displays. Flags of the United States and the Commonwealth of Massachusetts are not signs.
<b>Sign Band</b>	The area of a building, above a storefront, intended for the placement of a wall sign.
<b>Site</b>	A lot or parcel and the improvements thereon.
<b>Small Tree</b>	A woody plant with an expected mature height of less than thirty (30) feet.-
<b>Soil Volume</b>	An amount of soil provided for a tree, calculated as the horizontal area of open or covered soil multiplied by three (3) feet of depth.
<b>Solar Reflectance</b>	A measure of how strongly an object reflects sunlight. Solar reflectance is measured on a scale of 0 to 1: from not reflective (0) to 100% reflective (1.0).
<b>Solar Reflectance Index</b>	A combined measure of how well a surface reflects (reflectance) and releases absorbed solar radiation (emittance). Solar reflectance index is measured on a scale of 0 to 100: where a standard black surface (reflectance 0.05, emittance 0.90) is zero (0) and a standard white surface (reflectance 0.80, emittance 0.90) is one hundred (100). Solar reflectance index is abbreviated as SRI.

## 2. GLOSSARY & OVERVIEW

### Glossary

<b>Steep Slope</b>	Any change in elevation of twenty-five percent (25%) or greater over a horizontal distance of thirty (30) feet or greater.
<b>Step-back</b>	A recess of an upper story facade a set distance behind the facade of the story below.
<b>Story</b>	The portion of a building located between the surface of a habitable floor and the surface of the habitable floor or roof next above.
<b>Story, Ground</b>	The lowest story of a building with a finished floor at or above the finished ground level next to a building at the facade.
<b>Story, Upper Street</b>	Any story above the ground story of a building. A thoroughfare, avenue, road, highway, boulevard, parkway, driveway, lane, court or private easement for use by vehicular and pedestrian traffic and providing access to lots and civic spaces.
<b>Street Tree</b>	A tree planted within the furnishing zone as a element of a thoroughfare.
<b>Structured Parking</b>	Motor vehicle parking spaces located within a principal building, whether above-ground or underground, or carriage house.
<b>Structural Cells</b>	A subsurface system that supports the weight of sidewalks or other paved surfaces and is filled with uncompacted soil.
<b>Subdivision</b>	The division of a lot, tract, or parcel of land into two (2) or more lots, building sites, or other divisions for the purpose of sale, legacy, or development at any time, where a new thoroughfare or way is needed to provide access to the lots which would otherwise be landlocked.
<b>Substantial Rehabilitation</b>	Any modification, interior renovation, or both of an existing principal building that exceeds one hundred percent (100%) of the assessed value of the building, as identified on the most recent tax list maintained by the Assessor's Office of the City of Somerville, within any twelve (12) month period.
<b>Surface Parking</b>	Motor vehicle parking spaces provided at ground level, whether in a driveway, a parking lot, under a carport, or sheltered by overhanging upper stories of a building.
<b>Suspended Pavement</b>	Pavement slabs spanning supports that allow soil under sidewalks and other paved surfaces to remain uncompacted.
<b>Terminated Vista Thoroughfare</b>	A location at the axial conclusion of a thoroughfare. A public or private way for use by vehicular and pedestrian traffic and providing access to lots and civic spaces.
<b>Tower</b>	Any portion of a high-rise building above seventy (70) feet.
<b>Towing Service</b>	A specific use type of the Dispatch Service principal use category. See §9.2.3.b.i Towing Service.
<b>Transit Area</b>	All lots within one-quarter (1/4) mile of a transit station for commercial uses and all lots within one-half (1/2) mile of a transit station for residential uses.
<b>Transit Station</b>	Any existing or planned station of the MBTA's light rail and heavy rail rapid transit lines within the City of Somerville.
<b>Tree Guard</b>	A metal fence installed around the perimeter of a tree pit to protect a street tree.
<b>Tree Pit</b>	A three (3) foot deep pit filled with soil for the planting and growth of a tree. Tree pits have surface area open to air and water flow.
<b>Trucking or Transportation Depot</b>	An Industrial principal use category. See §9.2.8.g Trucking or Transportation Depot.
<b>Urban Agriculture Use</b>	An Accessory use category. See §9.2.14.b Urban Agriculture. The purpose or activity that land or structures is designed, arranged, or intended to be occupied or used, or for which it is occupied, maintained, rented, or leased.
<b>Vehicle Parking</b>	A Commercial Services principal use category (See §9.2.6.m Vehicle Parking) and an Accessory use category (See §9.2.14.e Vehicle Parking).
<b>Vehicle Sales</b>	An Auto-Oriented principal use category. See §9.2.3.e Vehicle Sales.



## 2. GLOSSARY & OVERVIEW

Glossary

<b>Visible Light Reflectance (VLR)</b>	The percent of total visible light that is reflected by a glazing system. The lower the number, the less visible light reflected.
<b>Visible Light Transmittance (VLT)</b>	The percent of total visible light that is transmitted through a glazing system. The lower the number, the less visible light transmitted.
<b>Waiver</b>	A predetermined type of deviation from specific provisions of this Ordinance as specifically indicated elsewhere in this Ordinance.
<b>Wholesale Trade or Distribution Wireless Communications</b>	An Industrial principal use category. See §9.2.8.h Wholesale Trade or Distribution. The provision of the following types of services: cellular telephone service; personal communications; and extended specialized mobile radio service. Such essential services will be provided via wireless communications facilities, which shall include monopoles, rooftop antennas, satellite dishes, and cell sites.
<b>Wireless Communications Antenna</b>	An antenna, dish, or cell site attached to a wireless communications tower, principal building, or other accessory structure that is used to transmit or receive wireless communications signals.
<b>Wireless Communications Tower</b>	A structure or structures intended to support equipment that is used to transmit and/or receive wireless communications signals including towers, monopoles, cell sites, and other guyed and lattice construction steel structures that are freestanding and not attached to an principal building type or accessory structure.
<b>Work/Live Creative Studio</b>	An Arts & Creative Enterprise principal use category. See §9.2.2.a Artisanal Production.

# 2. GLOSSARY & OVERVIEW

## Zoning Atlas Overview

### 2.2 ZONING ATLAS OVERVIEW

#### 1. Zoning Districts

- a. Zoning districts established by §1.4.2 of this Ordinance are summarized on Table 2.1.1 and example maps showing how districts are mapped to real property are shown in Figure 2.2.1 only for illustrative purposes.
- b. The colors indicated for each zoning district on Table 2.1.1 can be used to cross reference the Somerville Zoning Atlas with the applicable provisions for each zoning district of this Ordinance.

**Table 2.2.1 Zoning Districts**

#### Residential Districts (Article 3)

- Neighborhood Residential (NR)
- Urban Residential (UR)

#### Mid-Rise Districts (Article 4)

- Mid-Rise 3 STORY (MR3)
- Mid-Rise 4 STORY (MR4)
- Mid-Rise 5 STORY (MR5)
- Mid-Rise 6 STORY (MR6)

#### High Rise Districts (Article 5)

- High Rise (HR)

#### Commercial Districts (Article 6)

- Fabrication (FAB)
- Commercial Core (CC)
- Commercial Industry (CI)
- Commercial Business (CB)

#### Special Districts (Article 7)

- Civic (CIV)
- Assembly Square (ASQ)
- North Point (NP)
- Powderhouse School ReDEVELOPMENT (PSR)
- Tufts University (TU)

**Figure 2.2.1 Example Zoning Maps**



### 2. Transit Areas

- a. An example map illustrating how the TRANSIT AREAS established by §1.4.3 of this Ordinance are mapped to real property is shown in Figure 2.2.2 only for illustrative purposes.

### 3. Pedestrian Streets

- a. An example map illustrating how the PEDESTRIAN STREETS established by §1.4.4 of this Ordinance are mapped to real property is shown in Figure 2.2.3 only for illustrative purposes.

**Figure 2.2.2 Example TRANSIT AREAS Map**



**Map 2.2.3 Example Pedestrian STREETS Map**



## 2. GLOSSARY & OVERVIEW

### Building Types Overview

#### 2.3 BUILDING TYPES OVERVIEW

##### 1. General

- a. This Ordinance USES 'BUILDING TYPES' as a tool to regulate DEVELOPMENT within each zoning district.
- b. BUILDING TYPES are defined by the combined disposition, configuration, and function of a PRINCIPAL STRUCTURE BUILDING and are USED in this Ordinance to establish the standards for new construction, renovation of existing STRUCTURES, and REDEVELOPMENT.
- c. In contrast to applying generic dimensional standards to all PRINCIPAL STRUCTURES BUILDINGS, the USE of BUILDING TYPES as a regulatory tool allows dimensional standards to differ from one class or kind of STRUCTURE to another within the same district and is authorized by M.G.L. Chapter 40A, Section 4.
- d. The selection of BUILDING TYPES permitted within a zoning district combine with the mix of permitted USES to define the intended character of each zoning district.

##### 2. Building Assembly

- a. BUILDING TYPES are comprised of the MAIN MASSING of a BUILDING and various additional BUILDING COMPONENTS.
- b. The MAIN MASSING is the primary and the most important portion defining a BUILDING TYPE's form and scale. The MAIN MASSING of each BUILDING TYPE is regulated using dimensional standards that differ for each type.
- c. BUILDING COMPONENTS are ACCESSORY elements attached to the MAIN MASSING of a PRINCIPAL BUILDING that increase the buildings USEFULNESS. Each BUILDING component has dimensional standards that differ for each type.
- d. BUILDING COMPONENTS provide an important means for achieving variety and individuality in design and are permitted as indicated for each BUILDING TYPE.

Figure 2.3.2 Building Assembly

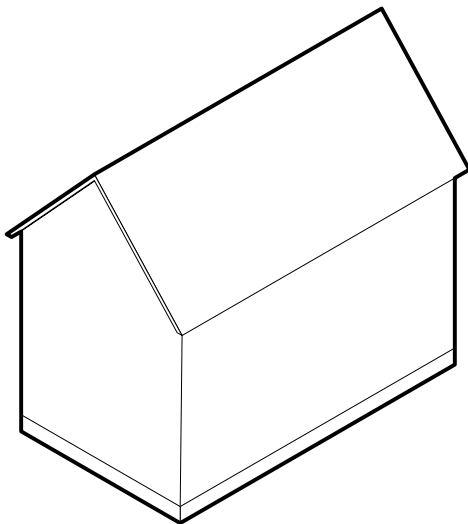

MAIN MASSING of a BUILDING

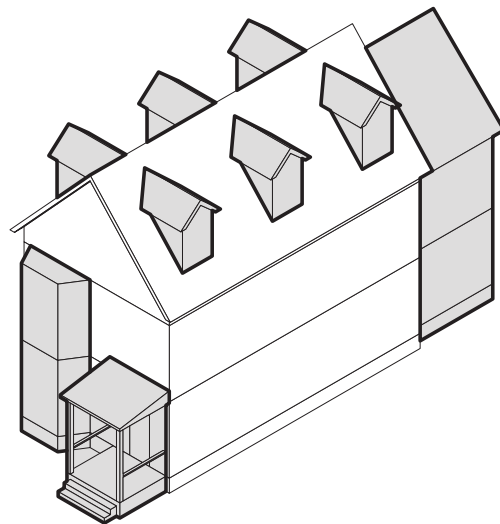

Additional BUILDING COMPONENTS

### 3. Understanding the Building Type Pages

- a. The standards for BUILDING TYPES identified in this Ordinance are presented across four pages that are the same for each BUILDING TYPE:
  - i. **Description & Precedents.** The first page for each BUILDING TYPE provides a general description and shows several images of typical buildings indicative of the variety possible within the definition of each type. The images are intended only for illustrative purposes and do not fully exemplify all of the requirements or possibilities for each type.
  - ii. **Diagrams & Dimensional Tables.** Page two and three provide the key spread of dimensional standards.
  - iii. **Additional Standards.** The fourth and final page for each BUILDING TYPE identifies various provisions applicable to the specific BUILDING TYPE, standards linked to the dimensional table, and includes any additional illustrative diagrams that are necessary.

- b. Section 2.2 provides an explanation of each line item in the BUILDING TYPE dimensional tables, defines how to measure each requirement, and provides other standards and reference information as necessary.

Badges indicate standards that are illustrated in the building type diagrams

Lot Standards

Building Standards

Color corresponds with Zoning District

3. RESIDENTIAL DISTRICTS  
Neighborhood Residence (NR)

8. Detached House (continued)

a. Lot Standards

b. Building Placement

8. Detached House (continued)

c. Massing & Height

d. Uses & Features

Zoning district labeled at the top of every page

Illustrative building type diagram

Tables of dimensional standards & other requirements

Width (min)	-
No Driveway Access	32 ft
Side or Rear Driveway Access	32 ft
Front Driveway Access	35 ft
Depth (min)	80 ft

Primary Front Setback <sup>1</sup> (min/max)	10 ft / 20 ft
Secondary Front Setback <sup>1</sup> (min/max)	10 ft / 20 ft
Side Setback (min)	0 ft
Sum of Side Setbacks (min)	10 ft
Rear Setback (min)	20 ft

Lot Coverage (max)	60%
Green Score	-
Minimum	0.35
Ideal	0.40

Primary Front Setback (min)	20 ft
Secondary Front Setback (min)	10 ft

<sup>1</sup> See §3.1.13.a Contextual Front Setbacks

Facade Build Out (min)	50%
Width (min/max)	22 ft / 28 ft
Depth (min/max)	28 ft / 48 ft
Building Height (max)	2.5
Story Height (min/max)	10 ft / 12 ft
Ground Floor Elevation (min)	2 ft
Roof Type	Flat, Gable, Gambrel, Hip, or Mansard

Ground Story Fenestration (min/max)	20% / 50%
Upper Story Fenestration (min/max)	20% / 50%

Dwelling Units per Lot (max)	4
Dwelling Units (max)	-
Outdoor Amenity Space (min)	1/ DU

# 2. GLOSSARY & OVERVIEW

## Standards & Measurements

### 2.4 STANDARDS & MEASUREMENTS

#### 1. General

a. This section provides an explanation of dimensional standards found in this Ordinance, defines how to measure each requirement, and provides other standards and reference information as necessary.

#### 2. Lot Standards

##### a. LOT LINES

- i. Any LOT LINE ABUTTING a PEDESTRIAN STREET IS a PRIMARY FRONT LOT LINE.
- ii. The FRONT LOT LINE of any INTERIOR LOT OR KEY LOT IS a PRIMARY FRONT LOT LINE.
- iii. CORNER LOTS have two FRONT LOT LINES and two SIDE LOT LINES with NO REAR LOT LINE.
  - a). Any FRONT LOT LINE of a CORNER LOT ABUTTING a PEDESTRIAN STREET IS a PRIMARY FRONT LOT LINE.
  - b). For all other CORNER LOTS, the PRIMARY FRONT LOT LINE IS designated by the PROPERTY OWNER, with all remaining FRONT LOT LINES designated as secondary FRONT LOT LINES.

##### b. LOT Dimensions

- i. LOT WIDTH
  - a). LOT WIDTH IS measured as the length of the FRONT LOT LINE of a LOT, except as follows:
    - i). For a FLAG LOT, only the 'pole' or 'post' portion of the LOT IS USED to measure LOT WIDTH.
- ii. LOT DEPTH
  - a). LOT DEPTH IS measured as the horizontal distance between the midpoint of the PRIMARY FRONT LOT LINE and the midpoint of the REAR LOT

LINE OR to the most distant point on any other LOT LINE where there IS NO REAR LOT LINE.

##### c. LOT DEVELOPMENT

- i. LOT Coverage
  - a). The maximum area of a LOT that IS permitted to be covered by STRUCTURES and impermeable surfaces. STRUCTURES are measured from the outside of the exterior walls at the GROUND STORY, including covered porches and other BUILDING COMPONENTS.
- ii. GREEN SCORE
  - a). GREEN SCORE IS landscape requirement measured as a ratio of the weighted value of various landscape elements to total LOT AREA. See §10.3 GREEN SCORE for more information.
- iii. OPEN SPACE
  - a). The minimum area of a LOT that must be provided as OPEN SPACE.

#### 3. Building Placement

##### a. BUILDING SETBACKS

- i. All principal and ACCESSORY BUILDINGS must be located at or behind any required minimum front, side, or rear SETBACK except as indicated in §2.2.3.c. SETBACK ENCROACHMENTS.
- ii. Minimum and maximum front SETBACKS are measured as follows:
  - a). Parallel to any FRONT LOT LINE that intersects a SIDE LOT LINE within five degrees (5°) of a right angle.
  - b). Parallel to the tangent of a concave FRONT LOT LINE OR to the secant of a CONVEX FRONT LOT LINE.

Figure 2.4.2 LOT Dimensions

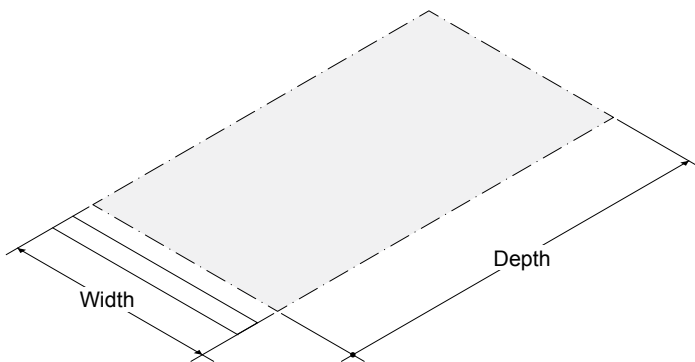
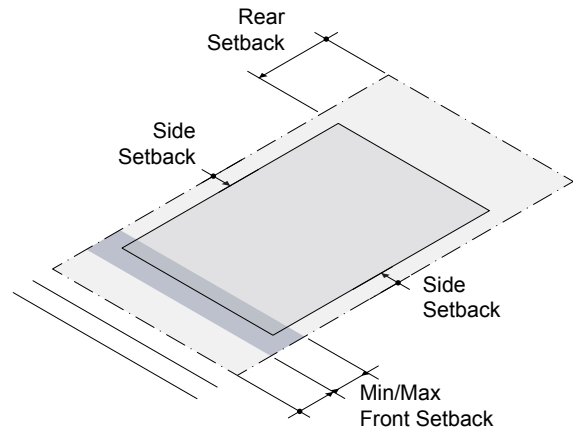

Figure 2.4.3 (a) Building SETBACKS



## 2. GLOSSARY & OVERVIEW

Standards & Measurements

- c). Perpendicular to the LOT DEPTH from the center point of the FRONT LOT LINE.
- iii. Side and rear SETBACKS are measured parallel to LOT LINES.
- iv. The FACADE of a PRINCIPAL BUILDING must be built at or in front of any maximum front SETBACK for each STORY of a BUILDING. The FACADE of UPPER STORIES may not project forward of the FACADE of the GROUND STORY except through the USE of Building COMPONENTS and BUILDING frontages.
- v. Buildings and STRUCTURES are not permitted to ENCROACH upon any EASEMENT or the right-of-way of any public THOROUGHFARE.
- vi. LOTS that cannot meet TOWER SETBACK requirements on all sides are not appropriate for tall buildings.
- b. Building Separation
  - i. Any principal or ACCESSORY BUILDING must be separated from any other principal or ACCESSORY BUILDING on the same LOT or on an ABUTTING LOT by the building separation distance specified for each BUILDING TYPE.
  - ii. Building separation is measured parallel from the face of the exterior walls of a principal or ACCESSORY BUILDING, excluding a PARTY WALL.
  - iii. Building components and the structural walls of window wells are included in the calculation of building separation.
- c. Parking SETBACKS
  - i. Unless otherwise specified, all parking, excluding underground parking, must be located at or behind any required parking SETBACK.
- d. SETBACK ENCROACHMENTS
  - i. BUILDING COMPONENTS may ENCROACH into required

SETBACK as indicated for each type elsewhere in this Ordinance.

- ii. CORNICES, belt courses, sills, PILASTERS and other architectural features may ENCROACH up to two (2) feet into a required SETBACK, provided that at least two (2) feet is maintained from the vertical plane of any SIDE LOT LINE.
- iii. Chimneys and flues may ENCROACH up to four (4) feet into a required SETBACK, provided that at least two (2) feet is maintained from the vertical plane of any LOT LINE.
- iv. BUILDING eaves and roof overhangs may ENCROACH into a required SETBACK, provided that at least two (2) feet is maintained from the vertical plane of any LOT LINE.
- v. Unenclosed fire escapes or emergency egress stairways may ENCROACH into a required side or rear SETBACK, provided that at least ten (10) feet is maintained from the vertical plane of any LOT LINE.
- vi. Mechanical equipment associated with residential USES, such as an HVAC unit, is not permitted in the FRONTAGE AREA of a LOT, but may ENCROACH into a required side or rear SETBACK, provided that at least two (2) feet or the distance provided in the manufacturer's specifications, whichever is greater, is maintained from the vertical plane of any LOT LINE.
  - a). Air heat pumps and other energy-saving mechanical equipment with a day-night 24-hr average noise level of 55 dB(A) or less may fully ENCROACH into a required SETBACK.
- vii. Exterior walls are permitted to ENCROACH into front, side, and rear SETBACKS up to eight inches (8") only for the purpose of adding insulating sheathing to

**Figure 2.4.3 (b) Parking SETBACKS**

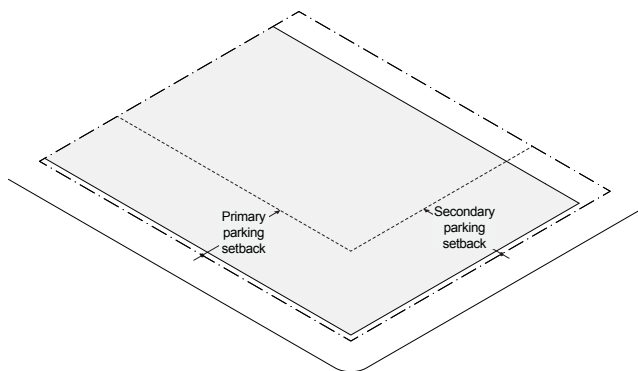

**Figure 2.4.2 (c) FRONTAGE AREA**

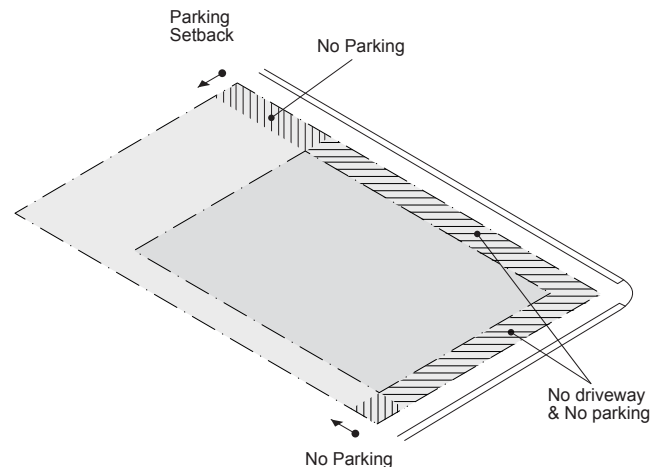



## 2. GLOSSARY & OVERVIEW

### Standards & Measurements

the exterior wall assembly, provided that at least two (2) feet is maintained from the vertical plane of any SIDE LOT LINE.

- viii. Minor STRUCTURES ACCESSORY to utilities, such as hydrants, manholes, water meters, or gas meters, may fully ENCROACH into a required front, side, or rear SETBACK.
  - ix. Transformers and other cabinet STRUCTURES may fully ENCROACH into a required side or rear SETBACK.
  - x. Terraces, uncovered and unenclosed PATIOS, and underground STRUCTURES may fully ENCROACH into a required SETBACK.
  - xi. Trellises or other STRUCTURES attached to a BUILDING for the sole purpose of growing vines or other vegetation may ENCROACH into a required SETBACK provided that at least two (2) feet is maintained from the vertical plane of any SIDE LOT LINE.
  - xii. ACCESSORY STRUCTURES, fences and walls, SIGNS, and landscape buffers may ENCROACH as indicated in Article 10: DEVELOPMENT Standards.
- e. FRONTAGE AREA
    - i. The area of a LOT between the FACADE of a PRINCIPAL BUILDING and any FRONT LOT LINE(s) extending fully to each SIDE LOT LINE(s) is the FRONTAGE AREA of a LOT.
    - ii. Parking is not permitted in the FRONTAGE AREA and driveways are not permitted in the FRONTAGE AREA between a BUILDING and the FRONT LOT LINE.

#### 4. Massing & Height

- a. General
  - i. The UPPER STORIES of a BUILDING may not project, in any direction, beyond the exterior wall plane of the

stories below, except through the use of Building COMPONENTS.

- b. MAIN MASSING
  - i. FACADE Build Out
    - a). Building façade(s) must be built parallel to the FRONT LOT LINE for the minimum façade build out specified for each BUILDING TYPE and is measured as a percentage of the LOT width, measured at the maximum front SETBACK line.
    - b). The review boards may permit buildings in the Neighborhood Residence district to have FACADES that are not parallel to a FRONT LOT LINE for any LOT where any SIDE LOT LINE intersects with the FRONT LOT LINE at an acute angle.
    - c). For LOTS with frontage on three (3) sides, the FACADE build out along a secondary frontage is only applicable to the minimum number of stories required for each BUILDING TYPE.
    - d). FORECOURTS are considered part of the BUILDING for the purpose of measuring FACADE build out.
  - ii. BUILDING WIDTH
    - a). Width is measured parallel to the FACADE of a BUILDING, from the exterior of each side wall.
  - iii. BUILDING Depth
    - a). Depth is measured perpendicularly from the FACADE as the maximum length of any exterior side wall of a BUILDING.
  - iv. FLOOR PLATE
    - a). FLOOR PLATE is measured as the total GROSS FLOOR AREA of each STORY of a BUILDING, measured at the exterior walls, but excluding BUILDING COMPONENTS.
  - v. GROUND STORY Elevation

Figure 2.4.4 (a) FACADE BUILD-OUT

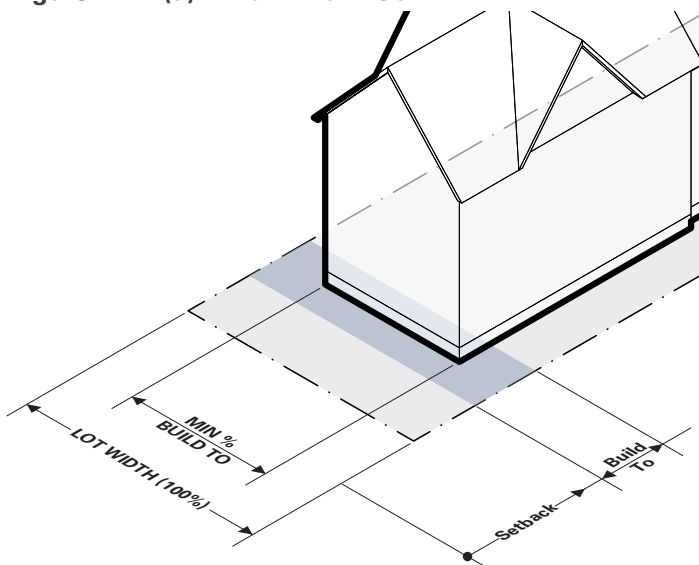
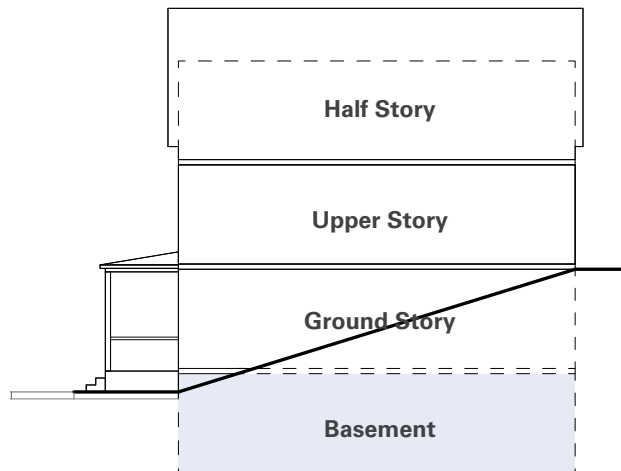
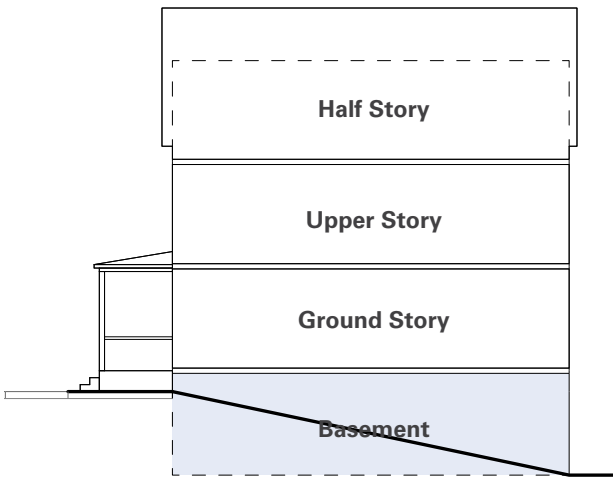

Figure 2.4.4 (b) Upward Slope





**Figure 2.4.4 (c) Downward Slope**



- a). GROUND STORY elevation is measured as the vertical distance from the average finished ground level at the FACADE(S) to the top of the finished floor of the GROUND STORY.
- vi. STORY Height
  - a). STORY height is measured vertically from the surface of the finished floor to the surface of the finished floor above at all points. When there is no floor above, STORY height is measured from the surface of the finished floor to the top of the structural beam or joists above or the top of the wall plate, whichever is more.
  - b). Minimum STORY height requirements are not measured for half-stories.
- vii. Number of Stories
  - a). The total number of stories of a BUILDING is calculated as follows:
    - i). The GROUND STORY is counted as one (1) STORY, except that a single GROUND STORY of twenty-five (25) feet or more is counted as two (2) stories.
    - ii). Each UPPER STORY is counted as one (1) additional STORY, except that any UPPER STORY with a MEZZANINE or loft is counted as two (2) stories.
    - iii). Interstitial space between stories is counted as an additional STORY if the space has a walking surface, permanent lighting, a ceiling height of seven feet six inches (7'6") or more, or is ACCESSED via a stairwell or elevator door.
    - iv). BASEMENTS are not counted as one (1) STORY unless the finished floor of the GROUND STORY is five (5) feet or more above the AVERAGE GROUND LEVEL of the LOT. See Figure 2.2 (g) and Figure 2.2 (h).
- v). Each STORY of above ground STRUCTURED PARKING is counted as one (1) STORY regardless of its relationship to HABITABLE stories, except that up to two (2) stories of above ground STRUCTURED PARKING may be counted as one (1) STORY when those stories are fully screened by a single GROUND STORY with an equal or greater STORY height.
- b). When BUILDING height allows for a half-STORY, the half STORY is counted as the HABITABLE space located directly under a pitched roof. The following standards apply:
  - i). The roof rafters must intersect the wall plate or top of wall frame of the exterior walls at a height no more than two (2) feet above the finished floor of the half-STORY.
  - ii). Ceiling height of a half STORY must not exceed twelve (12) feet in height at any point.
- c). Non-HABITABLE attic space located under a pitched roof is not counted as a half STORY.
- viii. UPPER STORY STEP-BACK
  - a). When required, any BUILDING that exceeds four (4) stories in height must STEP-BACK at the 5th STORY as indicated for each BUILDING TYPE.
    - i). Buildings on any LOT less than sixty-five (65) feet deep are exempt from the UPPER STORY STEP-BACK requirement.
- ix. BUILDING Height, Feet
  - a). BUILDING height in feet is measured as the vertical distance from the average finished ground level at the FACADE(S) to the top of the structural beam or joists of the upper most STORY.
- x. Roofs
  - a). Defined roof types are permitted as indicated for each BUILDING TYPE. If this line item is not identified on the BUILDING TYPE table, the roof is not regulated.
- xi. Roof Features
  - a). Roof DECKS are permitted only on FLAT ROOFS and must be SETBACK at least five (5) feet from any FACADE.
  - b). Mechanical & stairwell penthouses; roof mounted cellular, radio, and Internet transmission equipment; vents or exhausts; solar panels or skylights; flagpoles; belfries, chimneys, cupolas, monuments, parapets, spires, steeples, and other NON-HABITABLE architectural features are permitted on roofs.

## 2. GLOSSARY & OVERVIEW

### Standards & Measurements

Figure 2.4.5 (a) FENESTRATION

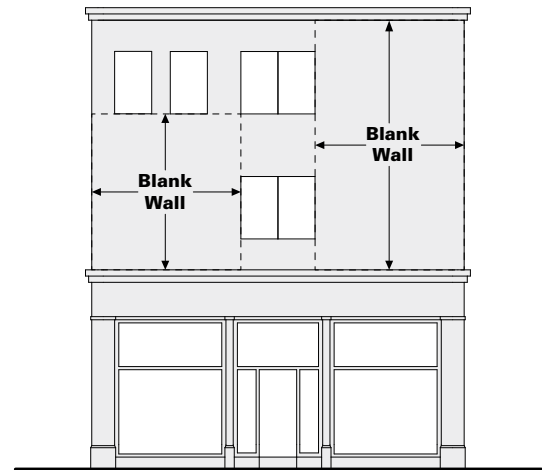
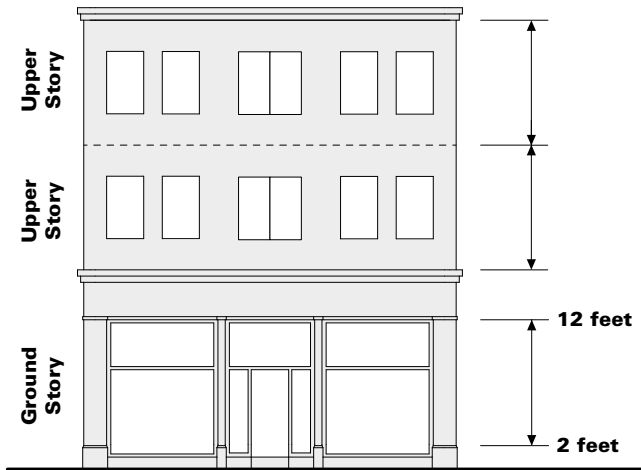

#### xii. FORECOURTS

- a). FORECOURTS must have a minimum width and depth of twelve (12) feet and a maximum height to width ratio of two to one (2:1).
- b). A FORECOURT must be enclosed by walls on three sides.
- c). BUILDING COMPONENTS may ENCROACH into a FORECOURT.
- d). Driveways, parking spaces, passenger drop-offs, garage entrances, loading and service areas, exhaust vents, mechanical equipment, and refuse or recycling storage are not permitted in FORECOURTS.

VISIBLE LIGHT TRANSMITTANCE (VLT) and no more than fifteen percent (15%) VISIBLE LIGHT REFLECTANCE (VLR).

- ii). For UPPER STORY FENESTRATION, glazing must have a minimum of forty percent (40%) VLT and no more than fifteen percent (15%) VLR.
- ii. BLANK WALL Area
  - a). BLANK WALL area is any portion of a FACADE that does not include FENESTRATION (doors and windows) and surface relief through the USE of columns, CORNICES, moldings, PIERS, PILASTERS, sills, SIGN BANDS, other equivalent architectural

## 5. Uses and Features

### a. FACADE Composition

#### i. FENESTRATION

- a). FENESTRATION must be provided as indicated for each BUILDING TYPE and is calculated as a percentage of the area of a FACADE.
  - i). For buildings with GROUND STORY commercial spaces, GROUND STORY FENESTRATION is measured between two (2) feet and twelve (12) feet above the finished floor of the GROUND STORY.
  - ii). For all other buildings and all other stories, FENESTRATION is measured independently for each STORY, from the top of a finished floor to the top of the finished floor above.
- b). FENESTRATION enclosed with glazing may be included in the calculation if it meets the following criteria:
  - i). For GROUND STORY FENESTRATION, glazing must have a minimum sixty percent (60%)

Figure 2.4.5 (b) Entrance Spacing

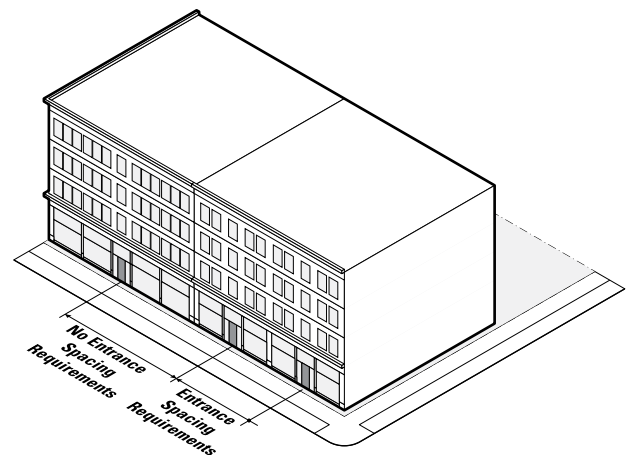

features that either recess or project from the average plane of the FACADE by at least four (4) inches.

- b). BLANK WALL area limitations apply both vertically and horizontally for all stories of a BUILDING for any FACADE.
- b. Use & Occupancy
  - i. Pedestrian ACCESS
    - a). Buildings must have at least one (1) PRINCIPAL ENTRANCE. PRINCIPAL ENTRANCES must be located on the FACADE, provide both ingress and egress, and be operable at all times.
    - b). Multi-STORY buildings with GROUND STORY commercial spaces must have at least one (1) PRINCIPAL ENTRANCE for each commercial space in addition to any PRINCIPAL ENTRANCE(s) necessary for accessing the upper stories.
    - c). PRINCIPAL ENTRANCE spacing is measured as the distance between center line of doors along a FACADE.
    - d). All residential buildings developed after the adoption date of this Ordinance must provide at least one (1) zero step entrance at the front, side, or rear of the building. Per Article VI of the Code of Ordinances of the City of Somerville, reasonable accomodation may be requested to comply with this standard.
    - e). Light wells may be provided within the FRONTAGE AREA to provide light and ACCESS into lower stories or to accommodate a change in grade across the front of a BUILDING.
    - f). The FRONTAGE AREA of a LOT may be terraced to accommodate pedestrian ACCESS where a change in grade exists across the front of a BUILDING.
  - ii. HABITABLE Space Depth
    - a). GROUND STORY DWELLING UNITS must have a HABITABLE room at least twenty (20) feet in depth, measured as the distance from the FACADE towards the interior of the BUILDING.
  - iii. GROUND STORY Commercial Space
    - a). Any building fronting a PEDESTRIAN STREET must provide GROUND STORY commercial space for one hundred percent (100%) of the total width of the building, excluding lobbies for UPPER STORY USES, means of egress, and any building systems rooms.
    - b). Required commercial space may be provided to one or more tenants and certain BUILDING TYPES may require more than one (1) commercial space.
  - iv. Commercial Space Depth
    - a). At least seventy percent (70%) of the LEASABLE FLOOR AREA of any GROUND STORY commercial

**Figure 2.4.5 (c) Commercial Space Depth**

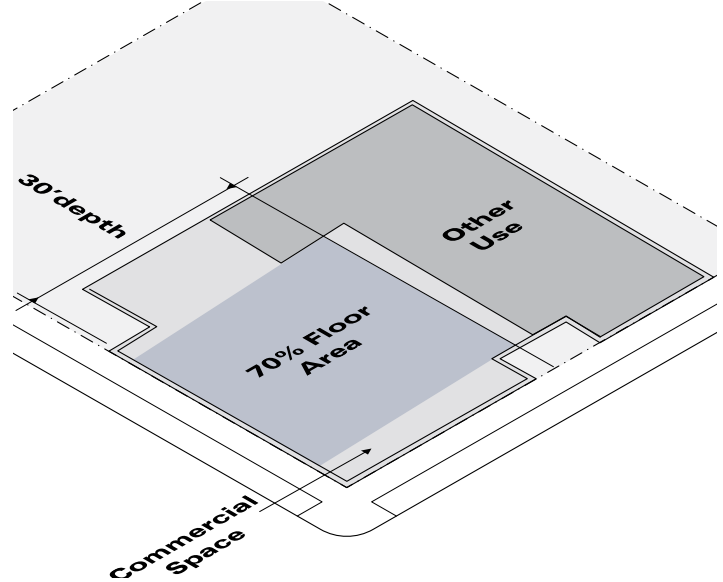

space must have the commercial space depth indicated for each BUILDING TYPE, measured as the distance from the FACADE towards the interior of a building.

- v. DWELLING UNITS per LOT
  - a). The total combined number of DWELLING UNITS, that are permitted within a PRINCIPAL BUILDING TYPE and ACCESSORY BUILDING TYPE on the same LOT.
- vi. DWELLING UNITS
  - a). The minimum or maximum number of DWELLING UNITS permitted for a BUILDING TYPE.
  - b). Existing structures may not be MODIFIED to conflict with number of DWELLING UNITS permitted for each BUILDING TYPE.
- vii. GROSS FLOOR AREA per DWELLING UNIT (GFA/DU)
  - a). The maximum number of DWELLING UNITS permitted for a BUILDING TYPE is equal to the total GROSS FLOOR AREA of the BUILDING, minus the NET FLOOR AREA of any parking, divided by the GFA/DU indicated for each BUILDING TYPE.
    - i). The GFA/DU permitted for each BUILDING TYPE is different for buildings on different sized LOTS, NET ZERO BUILDINGS, and 100% AFFORDABLE HOUSING.
- viii. Outdoor AMENITY SPACE
  - a). When required for a BUILDING TYPE, outdoor AMENITY SPACE must be provided as a balcony, DECK, PATIO, porch, roof DECK, roof terrace, or yard that is directly ACCESSIBLE by a doorway from a HABITABLE room within the DWELLING UNIT the outdoor AMENITY SPACE is meant to serve.
  - b). Each outdoor AMENITY SPACE must provide an unobstructed area of at least twenty-four (24) square feet that may be used for seating.

## 2. GLOSSARY & OVERVIEW

### Standards & Measurements

- c). Buildings with seven (7) or more DWELLING UNITS may provide shared outdoor AMENITY SPACE, provided that the space includes the total seating area required for each DWELLING UNIT that the shared space is meant to serve.

#### 6. Building Components

- a. Dimensions
  - i. Projection
  - ii. SETBACK ENCROACHMENT
    - a). The distance a component may ENCROACH into a required SETBACK, provided that at least two (2) feet is maintained from the vertical plane of any SIDE LOT LINE.
  - iii. CLEARANCE
  - iv. Seating Area, Clear
- b. Bays
- c. Entry Canopys
- d. Stoops
- e. Porticos
- f. Porchs
- g. Engaged Porchs
- h. All Dormers
  - i. If the face wall of a dormer is oriented toward the FRONT LOT LINE, the SETBACK requirements are similarly oriented.
- i. Window Dormers
- j. Shed Dormers
- k. Cross GABLES
- l. Projecting GABLES
- m. Side Wings
- n. Rear Additions

# 3 RESIDENTIAL DISTRICTS

<b>3.1</b>	<b>NEIGHBORHOOD RESIDENCE (NR) .....</b>	<b>35</b>
	Character Description	35
	Intent	36
	Purpose	36
	Applicability	36
	Development Review	36
	Building Types	36
	Building Components	61
	Building Design Standards	68
	Architectural Design Guidelines	69
	Use Provisions	70
	Development Standards	71
	Parking & Mobility	72
	Public Realm	73
<b>3.2</b>	<b>URBAN RESIDENCE (UR) .....</b>	<b>75</b>
	Character Description	75
	Intent	76
	Purpose	76
	Applicability	76
	Development Review	76
	Building Types	76
	Building Components	97
	Building Design Standards	103
	Architectural Design Guidelines	103
	Use Provisions	104
	Development Standards	105
	Parking & Mobility	106
	Public Realm	107



## 3.1 NEIGHBORHOOD RESIDENCE (NR)

### 1. Character Description

The Neighborhood Residence district is characterized by a variety of small and moderate FLOOR PLATE, one-, two-, and three-unit PRINCIPAL\_BUILDINGS with minimal front and side SETBACKS to help prioritize rear yard space. The district is almost entirely residential, with occasional neighborhood stores, schools, places of worship, and arts related uses and on advantageous SITES.





## 3. RESIDENTIAL DISTRICTS

### Neighborhood Residence (NR)

#### 2. Intent

- a. To implement the objectives of the COMPREHENSIVE PLAN of the City of Somerville.
- b. To conserve already established areas of detached and semi-detached residential buildings.

#### 3. Purpose

- a. To permit the DEVELOPMENT of one-, two-, and three-unit detached and semi-detached residential buildings on individual LOTS.
- b. To permit contextual MODIFICATIONS to existing detached and semi-detached residential buildings.
- c. To permit the adaptive REUSE of certain existing nonconforming buildings for arts & creative enterprise and retail USES compatible with residential areas.
- d. To create DWELLING UNIT types, sizes, and BEDROOM counts ideal for larger households in HOUSES, semi-attached HOUSES, duplexes, and triple DECKERS.
- e. To create DWELLING UNIT types, sizes, and BEDROOM counts ideal for smaller households in cottages and carriage HOUSES.

#### 4. Applicability

- a. The section is applicable to all real property within the Neighborhood Residence district as shown on the maps of the Official Zoning Atlas of the City of Somerville.

#### 5. Development Review

- a. DEVELOPMENT review is subject to the provisions of Article 15: Administration of this Ordinance.
- b. All DEVELOPMENT, excluding NORMAL MAINTENANCE, requires the submittal of a development review application to the BUILDING OFFICIAL and the issuance of a Certificate of Zoning Compliance prior to the issuance of a BUILDING Permit or Certificate of Occupancy.
- c. Proposed DEVELOPMENT may or may not necessitate the need for Subdivision Plan Approval, Site Plan Approval, a Special Permit, or a Hardship Variance based on the nature of the proposal. In such cases, additional DEVELOPMENT review is required in accordance with Article 15: Administration.
  - i. The Zoning Board of Appeals is the decision making authority for all DEVELOPMENT that requires a Special Permit or HardSHIP Variance in the Neighborhood Residence district.
- d. Upon verification that no additional DEVELOPMENT review is necessary, or completion of the required DEVELOPMENT review, the BUILDING OFFICIAL shall issue a Zoning Compliance Certificate to certify compliance with the provisions and procedures of this Ordinance.

#### 6. Building Types

- a. One (1) PRINCIPAL BUILDING TYPE and one (1) ACCESSORY BUILDING TYPE are permitted on each LOT.
- b. Unless otherwise specified, the following PRINCIPAL BUILDING TYPES are permitted in the Neighborhood Residence district:
  - i. Cottage
  - ii. Detached House
  - iii. Semi-Detached House
  - iv. Duplex
  - v. Detached Triple DECKER
- c. The detached triple DECKER BUILDING TYPE is permitted only on a compliant LOT that is either ABUTTING at the side or directly opposite on any THOROUGHFARE from a LOT with an existing triple DECKER BUILDING TYPE.
- d. The following ACCESSORY BUILDING TYPES are permitted by Site Plan Approval in the Neighborhood Residence district:
  - i. Carriage House
- e. ACCESSORY STRUCTURES are regulated according to Article 10: DEVELOPMENT Standards of this Ordinance.



## 3. RESIDENTIAL DISTRICTS

Neighborhood Residence (NR)

### 3.1.7 Cottage

A small FLOOR PLATE, detached, PRINCIPAL BUILDING TYPE with one (1) DWELLING UNIT. The cottage is the smallest type of detached PRINCIPAL BUILDING in Somerville. Two variants exist, one with a half-STORY under pitched roof and another with a full height second STORY and a shallow pitched roof or a FLAT ROOF.

The following images are examples from Somerville of the cottage BUILDING TYPE and are intended only for illustrative purposes.



# 3. RESIDENTIAL DISTRICTS

Neighborhood Residence (NR)

## 3.1.7 Cottage (continued)

a. LOT Standards

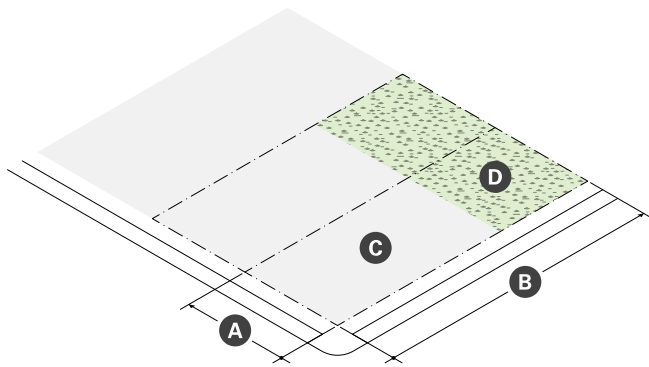

b. BUILDING Placement

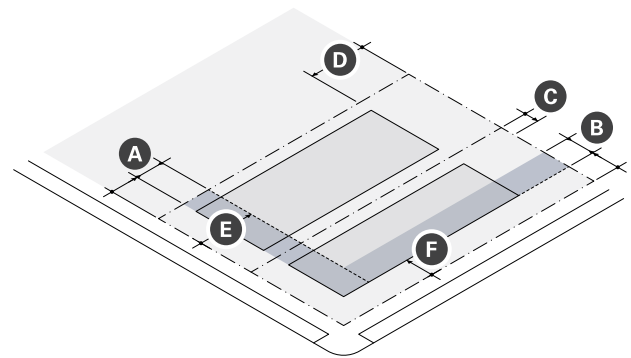

Lot Dimensions	
<b>A</b> LOT WIDTH (min)	–
No Driveway ACCESS	32 ft
Side or Rear Driveway ACCESS	32 ft
Front Driveway ACCESS	34 ft
<b>B</b> LOT DEPTH (min)	70 ft

Lot Development	
<b>C</b> LOT COVERAGE (max)	60%
<b>D</b> GREEN SCORE	–
Minimum	0.35
Ideal	0.40

Building Setbacks		
<b>A</b> Primary Front SETBACK <sup>1</sup> (min/max)	10 ft	20 ft
<b>B</b> Secondary Front SETBACK <sup>1</sup> (min/max)	10 ft	20 ft
<b>C</b> Side SETBACK (min)	–	
No Driveway ACCESS	5 ft	
Side or Rear Driveway ACCESS	5 ft	
Front Driveway ACCESS	3 ft	
Sum of Side SETBACKS (min)	–	
No Driveway ACCESS	10 ft	
Side or Rear Driveway ACCESS	10 ft	
Front Driveway ACCESS	12 ft	
<b>D</b> Rear SETBACK (min)	20 ft	
<b>E</b> Building Separation (min)	10 ft	

Parking Setbacks	
<b>F</b> Primary Front SETBACK (min)	20 ft
<b>G</b> Secondary Front SETBACK (min)	10 ft

<sup>1</sup> See §3.1.13.a Contextual Front SETBACKS

# 3. RESIDENTIAL DISTRICTS

Neighborhood Residence (NR)

## 3.1.7 Cottage (continued)

c. Massing & Height

d. Uses & Features

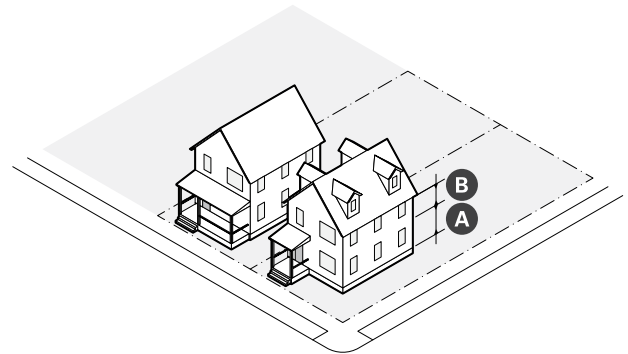
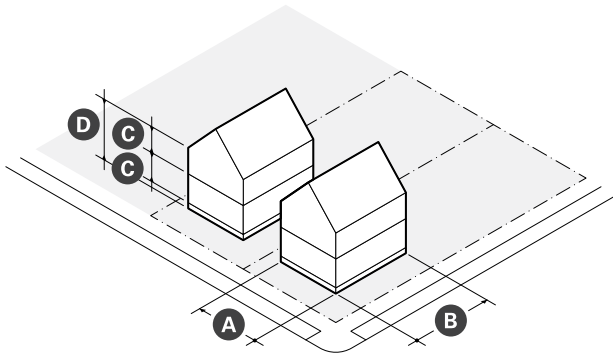

Main Mass	
FAÇADE Build Out (min)	60%
<b>A</b> Width (min/max)	22 ft 26 ft
<b>B</b> Depth (min/max)	24 ft 32 ft
GROUND STORY Elevation (min)	2 ft
<b>C</b> STORY Height (min/max)	10 ft 12 ft
<b>D</b> Number of Stories (max)	2
Roof Type	Flat, GABLE, MANSARD

Facade Composition	
<b>A</b> GROUND STORY FENESTRATION (min/max)	20% 50%
<b>B</b> UPPER STORY FENESTRATION (min/max)	20% 50%

Use & Occupancy	
DWELLING UNITS per LOT (max)	1
DWELLING UNITS (max)	1
Outdoor AMENITY SPACE (min)	1/ DU

## 3. RESIDENTIAL DISTRICTS

Neighborhood Residence (NR)

### 3.1.7 Cottage (continued)

e. Reserved.



# 3. RESIDENTIAL DISTRICTS

Neighborhood Residence (NR)

## 3.1.8 Detached House

A moderate FLOOR PLATE, detached, PRINCIPAL BUILDING TYPE with one (1) to three (3) vertically stacked DWELLING UNITS, where each unit typically has its own front door. The house is the most prevalent BUILDING TYPE in Somerville. When the second floor is split between the two DWELLING UNITS, this type is referred to as a “Philly Style”.

The following images are examples from Somerville of the house BUILDING TYPE and are intended only for illustrative purposes.



# 3. RESIDENTIAL DISTRICTS

Neighborhood Residence (NR)

## 3.1.8 Detached House (continued)

a. LOT Standards

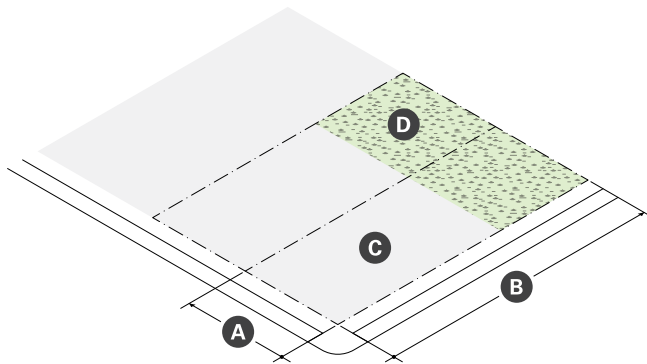

Lot Dimensions	
<b>A</b> LOT WIDTH (min)	–
No Driveway ACCESS	32 ft
Side or Rear Driveway ACCESS	32 ft
Front Driveway ACCESS	34 ft
<b>B</b> LOT DEPTH (min)	80 ft

Lot Development	
<b>C</b> LOT COVERAGE (max)	60%
<b>D</b> GREEN SCORE	--
Minimum	0.35
Ideal	0.40

b. BUILDING Placement

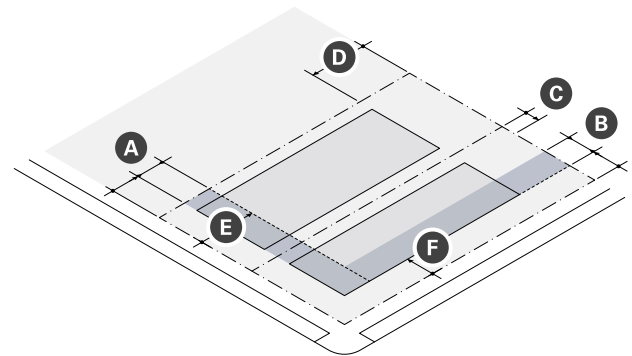

Building Setbacks		
<b>A</b> Primary Front SETBACK <sup>1</sup> (min/max)	10 ft	20 ft
<b>B</b> Secondary Front SETBACK <sup>1</sup> (min/max)	10 ft	20 ft
<b>C</b> Side SETBACK (min)	=	
No Driveway ACCESS	5 ft	
Side or Rear Driveway ACCESS	5 ft	
Front Driveway ACCESS	3 ft	
Sum of Side SETBACKS (min)	=	
No Driveway ACCESS	10 ft	
Side or Rear Driveway ACCESS	10 ft	
Front Driveway ACCESS	12 ft	
<b>D</b> Rear SETBACK (min)	20 ft	
<b>E</b> Building Separation (min)	10 ft	

Parking Setbacks	
<b>F</b> Primary Front SETBACK (min)	20 ft
<b>G</b> Secondary Front SETBACK (min)	10 ft

<sup>1</sup> See §3.1.13.a Contextual Front SETBACKS

# 3. RESIDENTIAL DISTRICTS

Neighborhood Residence (NR)

## 3.1.8 Detached House (continued)

c. Massing & Height

d. Uses & Features

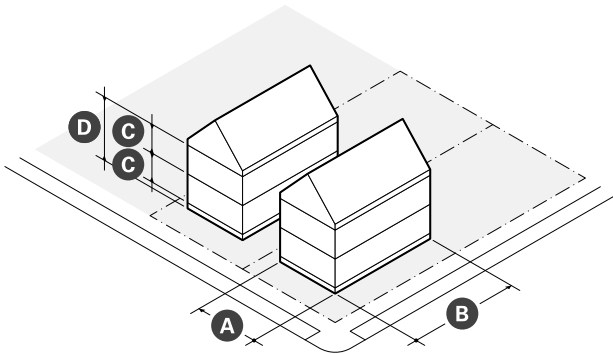

Main Mass	
FACADE Build Out (min)	50%
<b>A</b> Width (min/max)	22 ft 28 ft
<b>B</b> Depth (min/max)	28 ft 48 ft
GROUND STORY Elevation (min)	2 ft
<b>C</b> STORY Height (min/max)	10 ft 12 ft
<b>D</b> Number of STORIES (max)	2.5
Roof Type	Flat, GABLE, GAMBREL, HIP, or MANSARD

Facade Composition		
<b>A</b> GROUND STORY FENESTRATION (min/max)	20%	50%
<b>B</b> UPPER STORY FENESTRATION (min/max)	20%	50%

Use & Occupancy	
DWELLING UNITS per LOT (max)	3
DWELLING UNITS (max)	3
Outdoor AMENITY SPACE (min)	1/ DU



# 3. RESIDENTIAL DISTRICTS

Neighborhood Residence (NR)

## 3.1.8 Detached House (continued)

- e. Housing
  - i. Multiple DWELLING UNITS within a detached house BUILDING TYPE must be, generally, stacked one over the other. Common examples are shown in Figure 3.1.8. DWELLING UNITS that are side-by-side or front-to-back in orientation are not permitted.
- f. DEVELOPMENT Benefits
  - i. DEVELOPMENT is subject to the provisions of Article 12: DEVELOPMENT Benefits of this Ordinance. Where the provisions of this section conflict with those of Article 12, the provisions of Article 12 apply.
  - ii. DEVELOPMENT of a detached house PRINCIPAL BUILDING must provide AFFORDABLE DWELLING UNITS as specified on Table 3.1.8.
  - iii. Required ADUs must be priced as a Tier 3 ADU.

Table 3.1.8 Required ADUs

Dwelling Units per Lot	Required ADUs
0 to 2 units	None
3 units	1 unit

Figure 3.1.8 Dwelling Unit Orientation Options

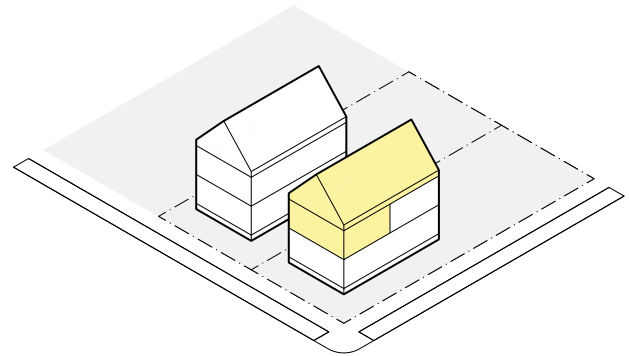
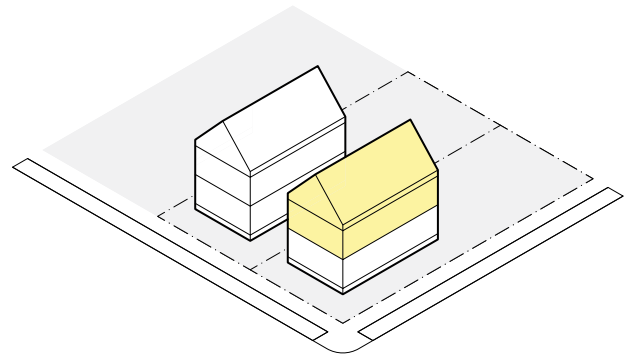

# 3. RESIDENTIAL DISTRICTS

Neighborhood Residence (NR)

## 3.1.9 Semi-Detached House

A moderate FLOOR PLATE, semi-detached, PRINCIPAL BUILDING TYPE with one (1) to three (3) vertically stacked DWELLING UNITS. A semi-detached house must be attached on one side to another semi-detached house by a PARTY WALL.

The following images are examples from Somerville of the semi-detached house BUILDING TYPE and are intended only for illustrative purposes.



# 3. RESIDENTIAL DISTRICTS

Neighborhood Residence (NR)

## 3.1.9 Semi-Detached House (continued)

a. LOT Standards

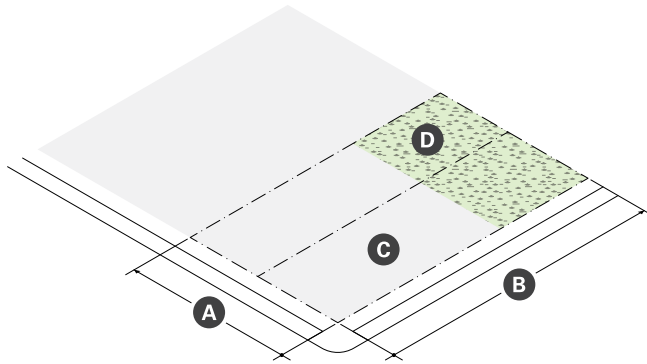

b. BUILDING Placement

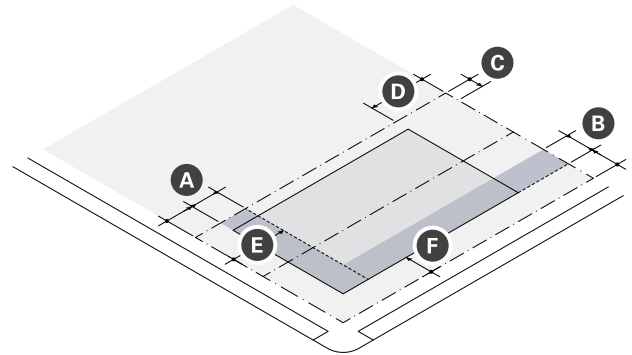

Lot Dimensions	
<b>A</b> LOT WIDTH (min)	--
No Driveway ACCESS	27 ft
Side or Rear Driveway ACCESS	27 ft
Front Driveway ACCESS	30 ft
<b>B</b> LOT DEPTH (min)	80 ft

Lot Development	
<b>C</b> LOT COVERAGE (max)	60%
<b>D</b> GREEN SCORE	--
Minimum	0.35
Ideal	0.40

Building Setbacks		
<b>A</b> Primary Front SETBACK <sup>1</sup> (min/max)	10 ft	20 ft
<b>B</b> Secondary Front SETBACK <sup>1</sup> (min/max)	10 ft	20 ft
<b>C</b> Side SETBACK (min)	--	
No Driveway ACCESS	5 ft	
Side or Rear Driveway ACCESS	5 ft	
Front Driveway ACCESS	8 ft	
Party Line SETBACK (min)	0 ft	
Sum of Side SETBACKS (min)	--	
No Driveway ACCESS	5 ft	
Side or Rear Driveway ACCESS	5 ft	
Front Driveway ACCESS	8 ft	
<b>D</b> Rear SETBACK (min)	20 ft	
<b>E</b> Building Separation (min)	10 ft	

Parking Setbacks	
<b>F</b> Primary Front SETBACK (min)	20 ft
<b>G</b> Secondary Front SETBACK (min)	10 ft

<sup>1</sup> See §3.1.13.a Contextual Front SETBACKS

# 3. RESIDENTIAL DISTRICTS

Neighborhood Residence (NR)

## 3.1.9 Semi-Detached House (continued)

c. Massing & Height

d. Uses & Features

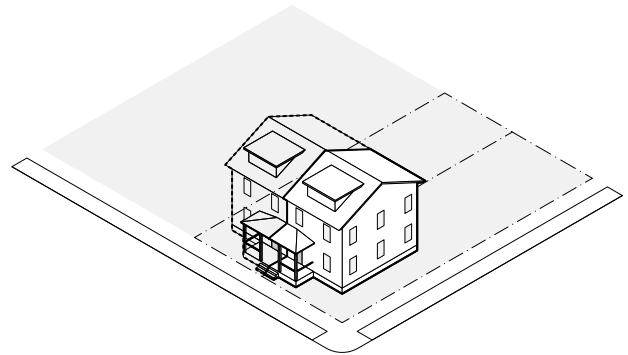
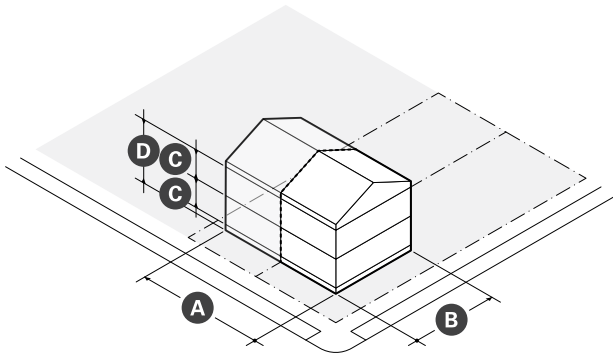

Main Massing	
FACADE Build Out (min)	50%
<b>A</b> Width (min/max)	22 ft 28 ft
<b>B</b> Depth (min/max)	28 ft 48 ft
GROUND STORY Elevation (min)	2 ft
<b>C</b> STORY Height (min/max)	10 ft 12 ft
<b>D</b> Number of Stories (max)	2.5
Roof Type	Flat, GABLE, HIP, MANSARD

Facade Composition		
<b>A</b> GROUND STORY FENESTRATION (min/max)	20%	50%
<b>B</b> UPPER STORY FENESTRATION (min/max)	20%	50%

Use & Occupancy	
DWELLING UNITS per LOT (max)	3
DWELLING UNITS (max)	3
Outdoor AMENITY SPACE (min)	1/ DU

# 3. RESIDENTIAL DISTRICTS

Neighborhood Residence (NR)

## 3.1.9 Semi-Detached House (continued)

- e. Housing
  - i. Multiple DWELLING UNITS within a semi-detached HOUSE BUILDING TYPE must be, generally, stacked one over the other. Common examples are shown in Figure 3.1.9. DWELLING UNITS that are side-by-side or front-to-back in orientation are not permitted.
- f. DEVELOPMENT Benefits
  - i. DEVELOPMENT is subject to the provisions of Article 12: DEVELOPMENT Benefits of this Ordinance. Where the provisions of this section conflict with those of Article 12, the provisions of Article 12 apply.
  - ii. DEVELOPMENT of a detached HOUSE PRINCIPAL BUILDING must provide AFFORDABLE DWELLING UNITS as specified on Table 3.1.9.
  - iii. Required ADUs must be priced as a Tier 3 ADU.

**Table 3.1.9 Required ADUs**

DWELLING UNITS per LOT	Required ADUs
0 to 2 units	None
3 units	1 unit

**Figure 3.1.9 DWELLING UNIT Orientation Options**

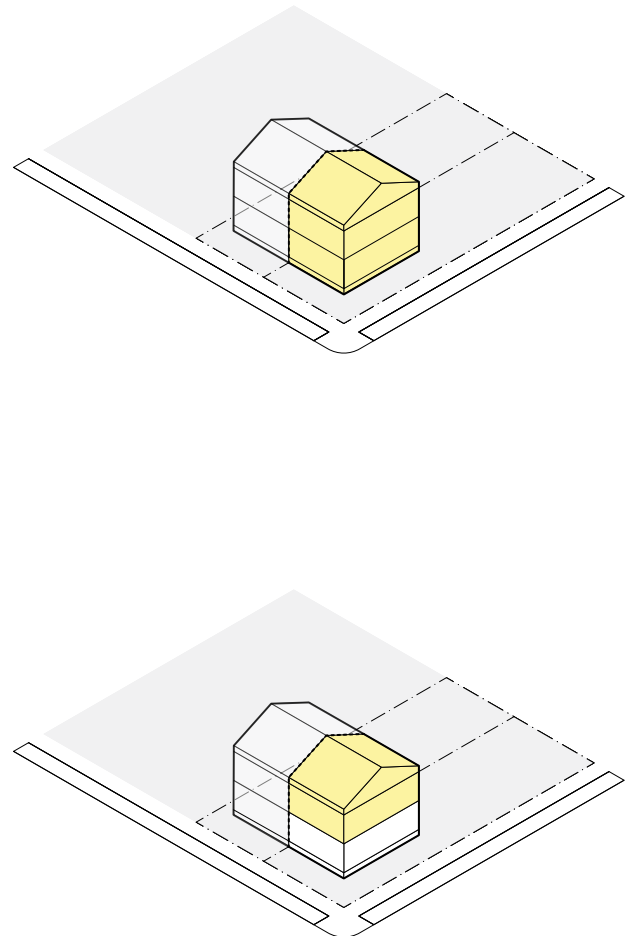



# 3. RESIDENTIAL DISTRICTS

Neighborhood Residence (NR)

## 3.1.10 Duplex

A moderate FLOOR PLATE, detached, PRINCIPAL BUILDING TYPE with two (2) side-by-side DWELLING UNITS. When occupying a CORNER LOT, the duplex may have DWELLING UNITS attached back to side so that one (1) DWELLING UNIT is oriented toward each frontage.

The following images are primarily examples from Somerville of the duplex BUILDING TYPE and are intended only for illustrative purposes.



# 3. RESIDENTIAL DISTRICTS

Neighborhood Residence (NR)

## 3.1.10 Duplex (continued)

a. LOT Standards

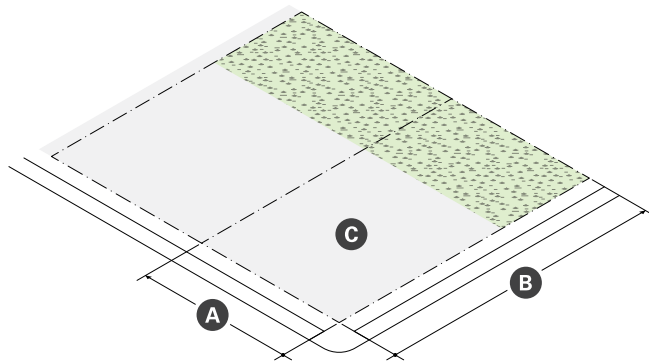

b. BUILDING Placement

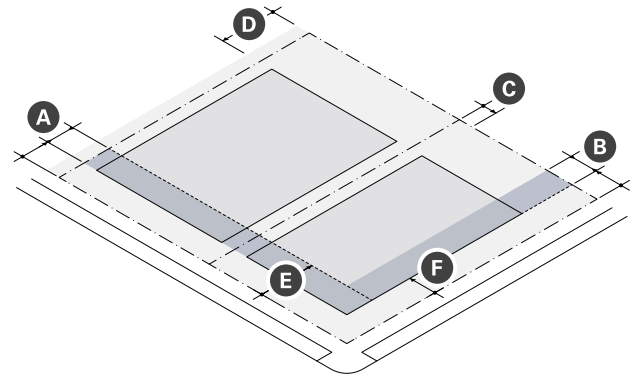

Lot Dimensions	
<b>A</b> LOT WIDTH (min)	--
No Driveway ACCESS	50 ft
Side or Rear Driveway ACCESS	50 ft
Front Driveway ACCESS	52 ft
<b>B</b> LOT DEPTH (min)	70 ft

Lot Development	
<b>C</b> LOT COVERAGE (max)	60%
GREEN SCORE	--
Minimum	0.35
Ideal	0.40

Building Setbacks		
<b>A</b> Primary Front SETBACK <sup>1</sup> (min/max)	10 ft	20 ft
<b>B</b> Secondary Front SETBACK <sup>1</sup> (min/max)	10 ft	20 ft
<b>C</b> Side SETBACK (min)	--	
No Driveway ACCESS	5 ft	
Side or Rear Driveway ACCESS	5 ft	
Front Driveway ACCESS	3 ft	
Sum of Side SETBACKS (min)	--	
No Driveway ACCESS	10 ft	
Side or Rear Driveway ACCESS	10 ft	
Front Driveway ACCESS	12 ft	
<b>D</b> Rear SETBACK (min)	20 ft	
<b>E</b> Building Separation (min)	10 ft	

Parking Setbacks	
<b>F</b> Primary Front SETBACK (min)	20 ft
<b>G</b> Secondary Front SETBACK (min)	10 ft

<sup>1</sup> See §3.1.13.a Contextual Front SETBACKS



# 3. RESIDENTIAL DISTRICTS

Neighborhood Residence (NR)

## 3.1.10 Duplex (continued)

c. Massing & Height

d. Uses & Features

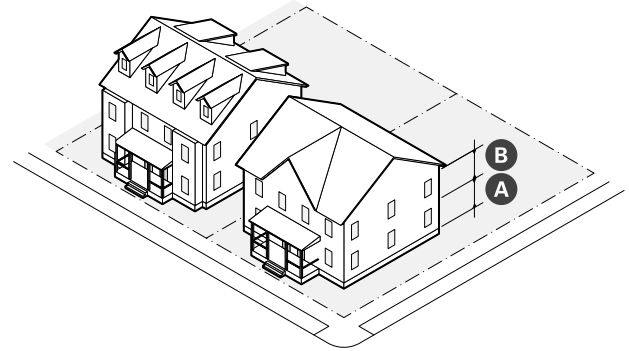
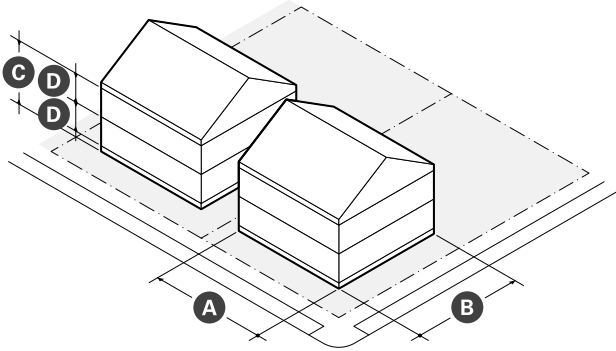

Main Massing	
FACADE Build Out (min)	50%
<b>A</b> Width (min/max)	40 ft 56 ft
<b>B</b> Depth (min/max)	30 ft 52 ft
GROUND STORY Elevation (min)	2 ft
<b>C</b> STORY Height (min/max)	10 ft 12 ft
<b>D</b> Number of Buildings (max)	2.5 stories
Roof Type	Flat, GABLE, HIP, MANSARD

Facade Composition		
<b>A</b> GROUND STORY FENESTRATION (min/max)	20%	50%
<b>B</b> UPPER STORY FENESTRATION (min/max)	20%	50%

Use & Occupancy	
DWELLING UNITS per LOT (max)	2
DWELLING UNITS (max)	2
Outdoor AMENITY SPACE (min)	1/ DU

# 3. RESIDENTIAL DISTRICTS

## Neighborhood Residence (NR)

### 3.1.10 Duplex (continued)

e. Housing

- i. The two (2) DWELLING UNITS within a duplex BUILDING TYPE must be side-by-side and both must be oriented toward the FRONT LOT LINE. On CORNER LOTS, one DWELLING UNIT may be oriented toward each FRONT LOT LINE resulting in units that are back-to-side in orientation. See Figure 3.1.10. DWELLING UNITS that are stacked one over the other or attached front to back in orientation are not permitted.

Figure 3.1.10 Dwelling Unit Orientation Options

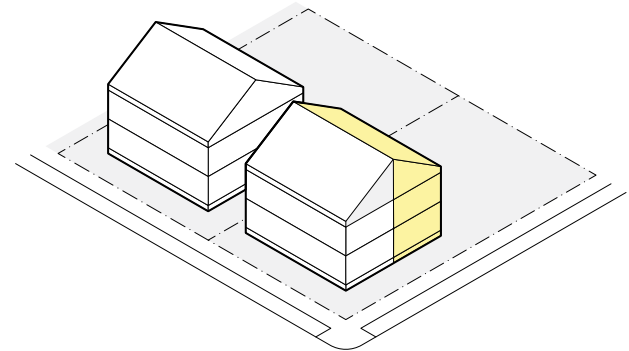
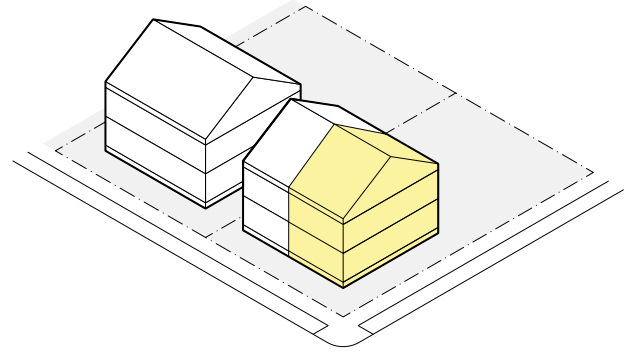

# 3. RESIDENTIAL DISTRICTS

Neighborhood Residence (NR)

## 3.1.11 Detached Triple Decker

A moderate FLOOR PLATE, detached, PRINCIPAL BUILDING TYPE with two (2) to three (3) vertically stacked DWELLING UNITS.

The following images are examples from Somerville of the detached triple DECKER BUILDING TYPE and are intended only for illustrative purposes.



# 3. RESIDENTIAL DISTRICTS

Neighborhood Residence (NR)

## 3.1.11 Detached Triple Decker (continued)

a. Lot Standards

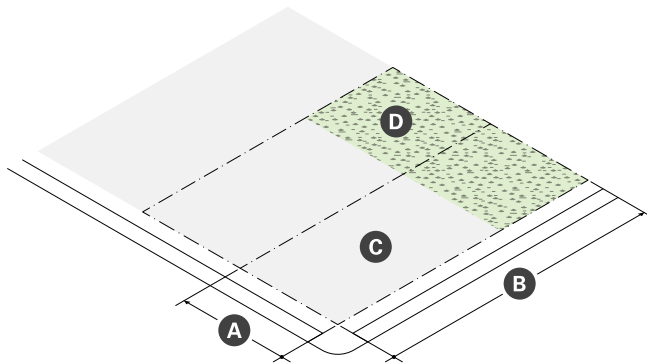

Lot Dimensions	
<b>A</b> LOT WIDTH (min)	--
No Driveway ACCESS	34 ft
Side or Rear Driveway ACCESS	34 ft
Front Driveway ACCESS	36 ft
<b>B</b> LOT DEPTH (min)	80 ft

Lot Development	
<b>C</b> LOT COVERAGE (max)	60%
<b>D</b> GREEN SCORE	--
Minimum	0.35
Ideal	0.40

b. BUILDING Placement

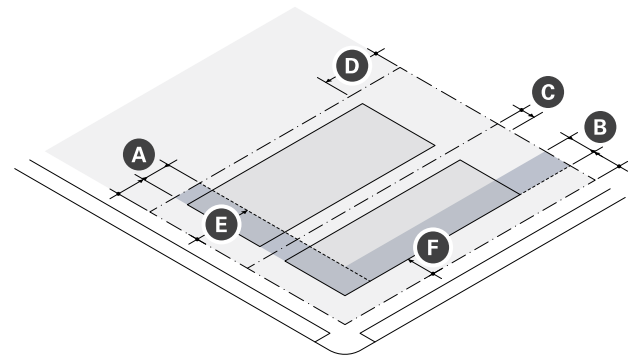

Building Setbacks		
<b>A</b> Primary Front SETBACK <sup>1</sup> (min/max)	10 ft	20 ft
<b>B</b> Secondary Front SETBACK <sup>1</sup> (min/max)	10 ft	20 ft
<b>C</b> Side SETBACK (min)	--	
No Driveway ACCESS	5 ft	
Side or Rear Driveway ACCESS	5 ft	
Front Driveway ACCESS	3 ft	
Sum of Side SETBACKS (min)	--	
No Driveway ACCESS	10 ft	
Side or Rear Driveway ACCESS	10 ft	
Front Driveway ACCESS	12 ft	
<b>D</b> Rear SETBACK (min)	20 ft	
<b>E</b> Building Separation (min)	10 ft	

Parking Setbacks	
<b>F</b> Primary Front SETBACK (min)	20 ft
<b>G</b> Secondary Front SETBACK (min)	10 ft

<sup>1</sup> See §3.1.13.a Contextual Front SETBACKS

# 3. RESIDENTIAL DISTRICTS

Neighborhood Residence (NR)

## 3.1.11 Detached Triple Decker (continued)

c. Massing & Height

d. Uses & Features

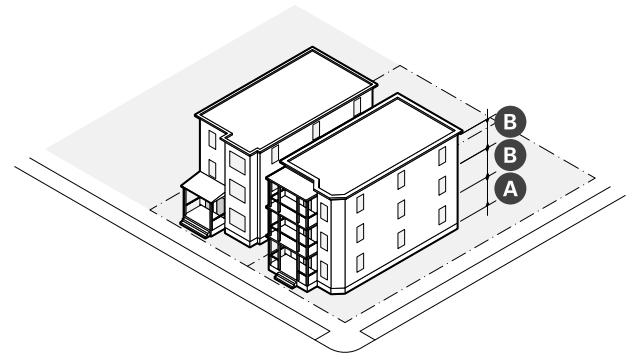
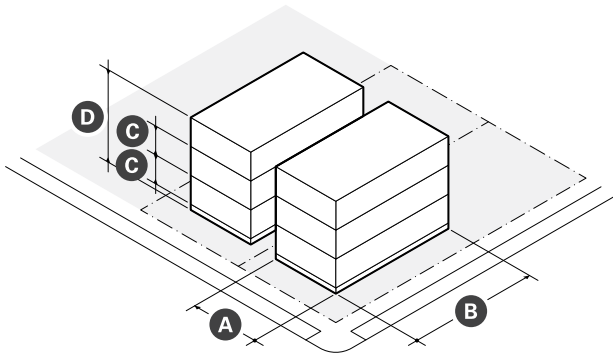

Main Massing	
FACADE Build Out (min)	60%
<b>A</b> Width (min/max)	24 ft 30 ft
<b>B</b> Depth (min/max)	36 ft 50 ft
GROUND STORY Elevation (min)	2 ft
<b>C</b> STORY Height (min/max)	10 ft 12 ft
<b>D</b> Number of Stories (max)	3 stories
Roof Type	Flat

Facade Composition	
<b>A</b> GROUND STORY FENESTRATION (min/max)	20% 50%
<b>B</b> UPPER STORY FENESTRATION (min/max)	20% 50%

Use & Occupancy	
DWELLING UNITS per LOT (max)	3
DWELLING UNITS (max)	3
Outdoor AMENITY SPACE (min)	1/ DU

# 3. RESIDENTIAL DISTRICTS

Neighborhood Residence (NR)

## 3.1.11 Detached Triple Decker (continued)

- e. Housing
  - i. Multiple DWELLING UNITS within a detached triple DECKER BUILDING TYPE must be, generally, stacked one over the other. Common examples are shown in Figure 3.1.11. DWELLING UNITS that are side-by-side or front-to-back in orientation are not permitted.
- f. DEVELOPMENT Benefits
  - i. DEVELOPMENT is subject to the provisions of Article 12: DEVELOPMENT Benefits of this Ordinance. Where the provisions of this section conflict with those of Article 12, the provisions of Article 12 apply.
  - ii. DEVELOPMENT of a detached triple DECKER must provide AFFORDABLE DWELLING UNITS as specified on Table 3.1.11.
  - iii. Required ADUs must be priced as a Tier 3 ADU.

**Table 3.1.11 Required ADUs**

DWELLING UNITS per LOT	Required ADUs
0 to 2 units	None
3 units	1 unit

**Figure 3.1.11 DWELLING UNIT Orientation**

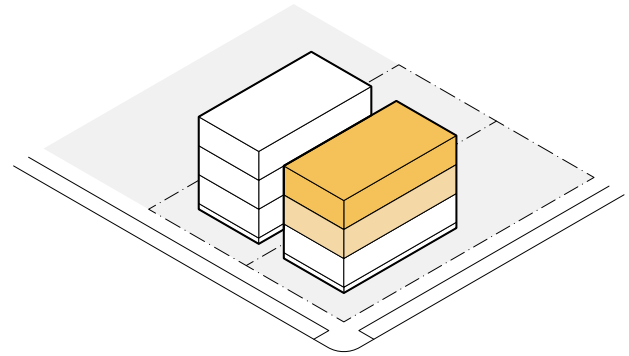



# 3. RESIDENTIAL DISTRICTS

Neighborhood Residence (NR)

## 3.1.12 Carriage House

A small FLOOR PLATE, detached, ACCESSORY BUILDING TYPE typically providing space for one (1) small DWELLING UNIT, a home OCCUPATION, creative studio space, shed storage, a playhouse for children, or vehicular parking.

The following images are examples from Somerville of the carriage house OUTBUILDING TYPE and are intended only for illustrative purposes.





# 3. RESIDENTIAL DISTRICTS

Neighborhood Residence (NR)

## 3.1.12 Carriage House (continued)

a. LOT Standards

b. BUILDING Placement

Lot Dimensions	
<b>A</b> LOT WIDTH (min)	–
No Driveway ACCESS	32 ft
Side or Rear Driveway ACCESS	32 ft
Front Driveway ACCESS	34 ft
<b>B</b> LOT DEPTH (min)	80 ft

Lot Development	
<b>C</b> LOT Coverage (max)	per PRINCIPAL BUILDING
<b>D</b> GREEN SCORE (min)	per PRINCIPAL BUILDING

Building Setbacks	
<b>A</b> Primary Front SETBACK (min)	60 ft
<b>B</b> Secondary Front SETBACK (min)	10 ft
<b>C</b> Side SETBACK (min)	3 ft
<b>E</b> Rear SETBACK (min)	3 ft
ALLEY	3 or 20 ft
No ALLEY	3 ft
<b>E</b> Building Separation (min)	10 ft

# 3. RESIDENTIAL DISTRICTS

Neighborhood Residence (NR)

## 3.1.12 Carriage House (continued)

c. Massing & Height

d. Uses & Features

Main Massing	
<b>A</b> Width (min/max)	18 ft 36 ft
<b>B</b> Depth (min/max)	20 ft 30 ft
GROUND STORY Elevation (min)	0 ft
<b>D</b> STORY Height (min/max)	10 ft 12 ft
<b>C</b> Number of Stories (max)	2 stories
Roof Type	Any

Facade Composition	
<b>A</b> GROUND STORY FENESTRATION (min/max)	20% 50%
<b>B</b> UPPER STORY FENESTRATION (min/max)	20% 50%

Use & Occupancy	
DWELLING UNITS per LOT (max)	per PRINCIPAL BUILDING
DWELLING UNITS (max)	1

## 3. RESIDENTIAL DISTRICTS

### Neighborhood Residence (NR)

#### 3.1.12 Carriage House (continued)

- e. Housing
  - i. Reserved
- f. DEVELOPMENT Benefits
  - i. DEVELOPMENT is subject to the provisions of Article 12: DEVELOPMENT Benefits of this Ordinance. Where the provisions of this section conflict with those of Article 12, the provisions of Article 12 apply.
  - ii. DEVELOPMENT of a Carriage House ACCESSORY BUILDING may or may not require a DWELLING UNIT to be an AFFORDABLE DWELLING UNIT based on the number DWELLING UNITS provided in the PRINCIPAL BUILDING on the same LOT. See the standards for each PRINCIPAL BUILDING TYPE for additional information.
  - iii. Required ADUs must be priced as a Tier 3 ADU.
- g. Design Standards
  - i. A three (3) foot wide paved walkway capable of allowing an ambulance cot to be wheeled to and from the carriage house is required.
  - ii. Utility services for the carriage house must be buried underground.
  - iii. By order of the Fire Prevention Bureau, carriage houses occupied by any permitted Residential PRINCIPAL USE must have an AUTOMATIC SPRINKLER SYSTEM unless they are on a CORNER LOT, a LOT with a driveway leading to the carriage house, or a LOT ABUTTING AN ALLEY.

### 3. RESIDENTIAL DISTRICTS

Neighborhood Residence (NR)

#### 13. Building Components

- a. BUILDING COMPONENTS are ACCESSORY elements attached to the MAIN MASSING of a PRINCIPAL BUILDING.
- b. BUILDING COMPONENTS are permitted as specified on Table 3.1.13.
- c. Building components that are not identified on Table 3.1.13 are prohibited.
- d. Unless otherwise specified, BUILDING COMPONENTS may attach to other BUILDING COMPONENTS to create assemblies of components.

**Table 3.1.13 Building Components**

	Cottage	Detached House	Semi-Detached House	Duplex	Detached Triple Decker	Carriage House
Entry Canopy	P	P	P	P	P	P
Stoop	P	P	P	P	P	P
Portico	P	P	P	P	P	P
Projecting Porch	P	P	P	P	P	P
Engaged Porch	P	P	P	P	N	N
Bay	P	P	P	P	P	N
Dormer	P	P	P	P	N	P
Shed Dormer	P	P	P	P	N	P
Cross Gable	P	P	P	P	N	P
Projecting Gable	P	P	P	P	N	N
Side Wing	P	P	P	P	N	N
Rear Addition	P	P	P	P	N	N

P - Permitted    SP - Special Permit Required    N - Not Permitted

### 3. RESIDENTIAL DISTRICTS

Neighborhood Residence (NR)

#### e. Entry Canopy

- i. An entry canopy is a wall-mounted structure that provides shade and weather protection over the entrance of a BUILDING.

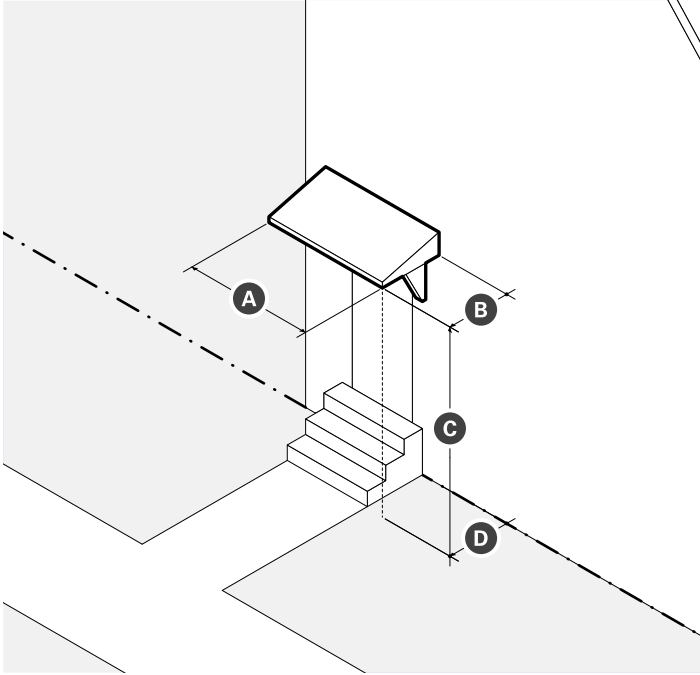

Dimensions	
<b>A</b> Width (min)	See §3.1.11.D.ii.b
<b>B</b> Projection (max)	3 ft
<b>C</b> CLEARANCE (min)	7 ft
<b>D</b> SETBACK ENCROACHMENT (max)	--
Front	100%
Side	0 ft
Rear	0 ft

- ii. Standards
  - a). Entry canopies must be visually supported by brackets, cables, or rods.
  - b). The width of an entry canopy must be equal to or greater than the width of the doorway surround, trim, or exterior casing it is mounted above.

#### f. Stoop

- i. A stoop is a set of stairs with a landing that provides ACCESS to the entrance of a BUILDING.

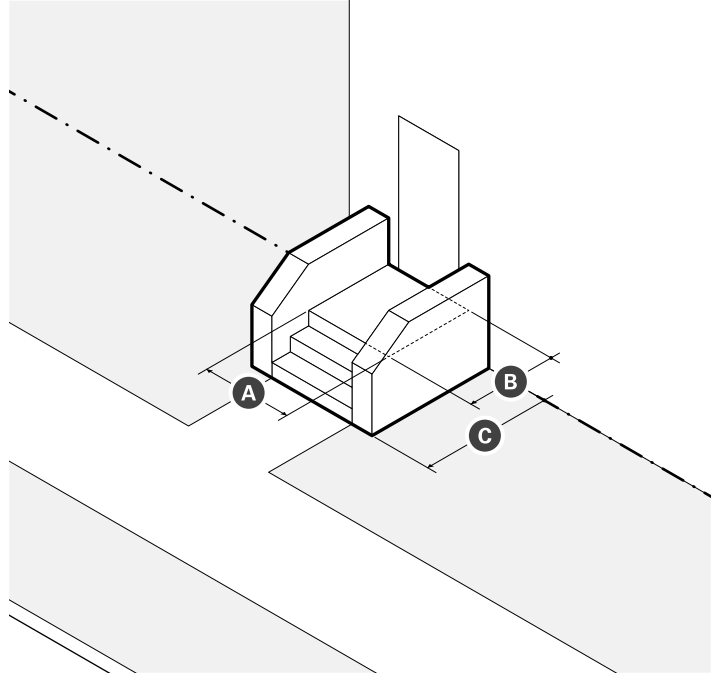

Dimensions	
<b>A</b> Landing Width (min)	4 ft
<b>B</b> Landing Depth (min)	4 ft
<b>C</b> SETBACK ENCROACHMENT (max)	--
Front	100%
Side	0 ft
Rear	0 ft

- ii. Standards
  - a). Stairs may be recessed into the BUILDING FACADE when the BUILDING is set back four (4) feet or less.
  - b). Stairs are not permitted to ENCROACH onto any ABUTTING sidewalk.
  - c). Stairs may be built perpendicular or parallel to the BUILDING FACADE, but must lead directly to ground level or an ABUTTING sidewalk.

# 3. RESIDENTIAL DISTRICTS

Neighborhood Residence (NR)

## g. Portico

- i. A portico is a raised platform with a roof supported by columns, PIERS, or posts and set of stairs with a landing that provides ACCESS to the entrance of a BUILDING.

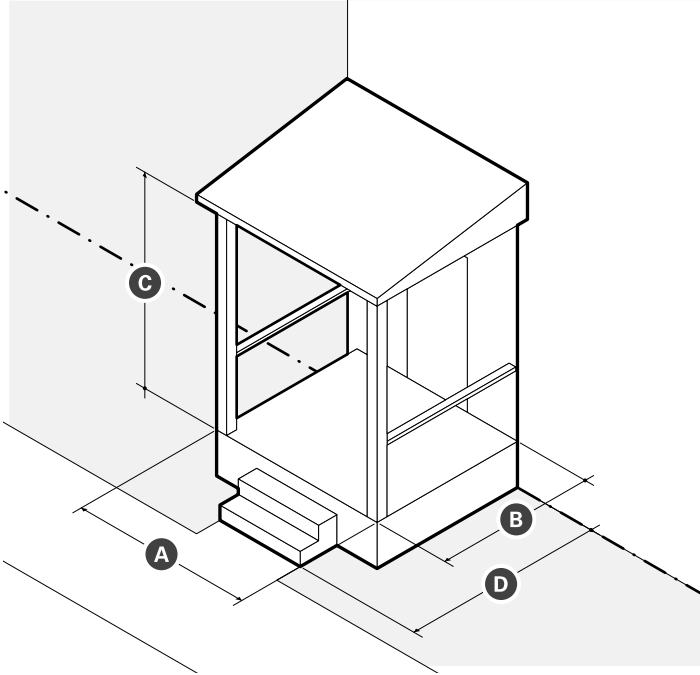

Dimensions	
<b>A</b> Landing Width (min)	4 ft
<b>B</b> Landing Depth (max)	4 ft
<b>C</b> CLEARANCE (min)	7 ft
<b>D</b> SETBACK ENCROACHMENT (max)	--
Front	100%
Side	0 ft
Rear	0 ft

- ii. Standards
  - a). Stairs are not permitted to ENCROACH onto any ABUTTING sidewalk.
  - b). Stairs may be built perpendicular or parallel to the BUILDING FACADE, but must lead directly to ground level or an ABUTTING sidewalk.

## h. Porch

- i. A porch is a wide, raised platform with a roof supported by columns, PIERS, or posts; an area for seating; and set of stairs with a landing that provides ACCESS to the entrance of a BUILDING.

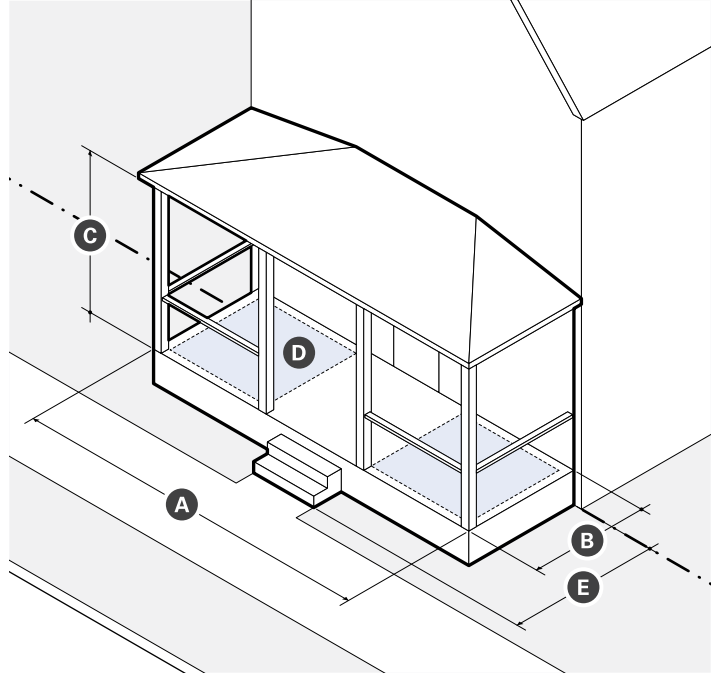

Dimensions	
<b>A</b> Width (min)	10' or 50% of FACADE width, whichever is greater
<b>B</b> Projection (min)	6 ft
<b>C</b> CLEARANCE (min)	7 ft
<b>D</b> FURNITURE AREA, Clear (min)	6 ft x 6 ft
<b>D</b> SETBACK ENCROACHMENT (max)	--
Front	100%
Side	0 ft
Rear	0 ft

- ii. Standards
  - a). Stairs are not permitted to ENCROACH onto any ABUTTING sidewalk.
  - b). Porch railings must permit visual supervision of the PUBLIC REALM through the posts and rails.
  - c). A porch may be screened provided the percentage of window area to wall area is seventy percent (70%) or greater. Permanent enclosure of a porch to create year-round living space is not permitted.

### 3. RESIDENTIAL DISTRICTS

#### Neighborhood Residence (NR)

#### i. Engaged Porch

- i. An engaged porch is a porch attached to a BUILDING at two sides, one to the FACADE and the other to a mud room or entry foyer.

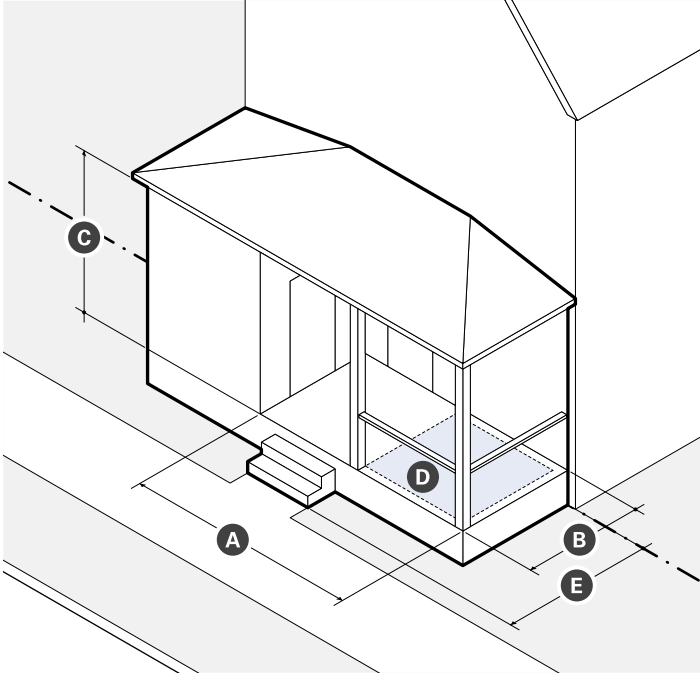

Dimensions	
<b>A</b> Width (min)	10' or 50% of FACADE width, whichever is greater
<b>B</b> Depth (min)	6 ft
<b>C</b> CLEARANCE (min)	8 ft
<b>D</b> FURNITURE AREA, Clear (min)	6 ft x 6 ft
<b>E</b> SETBACK ENCROACHMENT (max)	--
Front	100%
Side	0 ft
Rear	0 ft

- ii. Standards
  - a). Stairs are not permitted to ENCROACH onto any ABUTTING sidewalk.
  - b). Porch railings must permit visual supervision of the PUBLIC REALM through the posts and rails.
  - c). A porch may be screened provided that the percentage of window area to wall area is seventy percent (70%) or greater. Permanent enclosure of a porch to create year-round living space is not permitted.

#### j. Bay Window

- i. A bay window is an assembly of windows projecting from a building to provide additional HABITABLE space, increased light, multi-directional views, and ARTICULATION to an exterior wall.

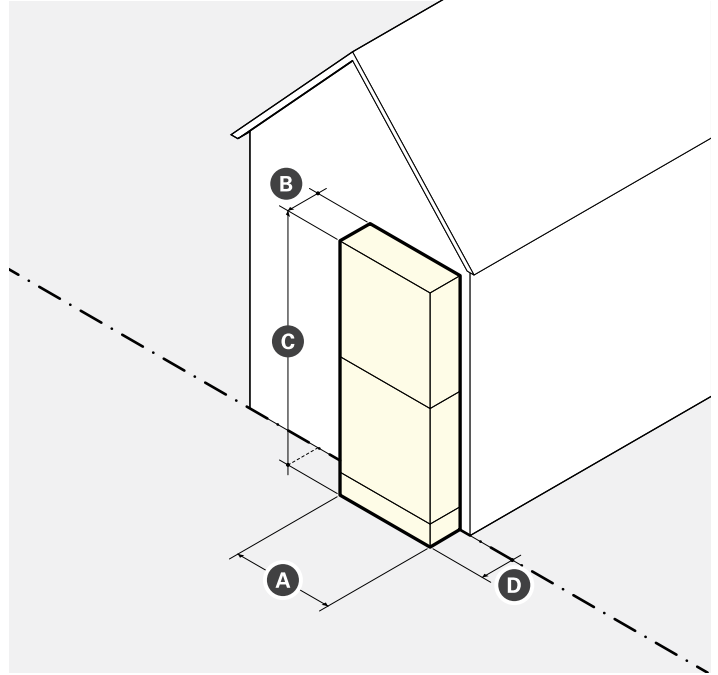

Dimensions	
<b>A</b> Width (max)	16 ft
<b>B</b> Projection (max)	3 ft
<b>C</b> Height (max)	Height of BUILDING in Stories
<b>D</b> SETBACK ENCROACHMENT (max)	--
Front	3 ft
Side	0 ft
Rear	0 ft

- ii. Standards
  - a). Bay windows, including box and bow windows, must include at least three (3) windows.
  - b). The cumulative width of multiple bays may equal up to fifty percent (50%) of the width of the exterior wall from which the bays project.
  - c). Bays projecting over the sidewalk of a public THOROUGHFARE must have at least two (2) stories of CLEARANCE and be compliant with all City Ordinances.



### 3. RESIDENTIAL DISTRICTS

Neighborhood Residence (NR)

#### k. Dormer

- i. A dormer is a window space with a GABLE, HIP, or arched roof that projects perpendicularly from a pitched roof below. Dormer windows provide light to the HABITABLE space of a half-STORY.

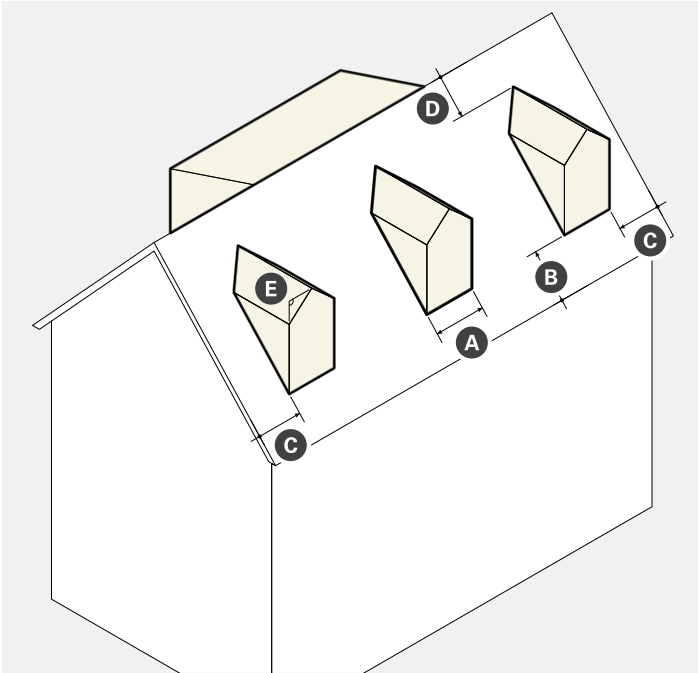

Dimensions	
<b>A</b> Width (max)	window(s) width + 18 in
Side Wall SETBACK (min)	–
Roof with eave	0 ft
Roof without eave	1 ft
<b>B</b> Front & Rear Wall SETBACK (min)	3 ft
<b>C</b> Ridge SETBACK (min)	1 ft
<b>D</b> Roof Slope (min)	4:12 (18.43°)
<b>E</b> Dormer Separation (min)	50% of dormer width

- ii. Standards
  - a). The face wall of a dormer window may not project beyond the exterior wall of the BUILDING and may not interrupt the eave of the roof.
  - b). Dormer windows may be combined with a shed dormer(s) to create a Nantucket dormer.
  - c). The cumulative width of a single, multiple, or attached combinations of dormers may equal up to fifty percent (50%) of the eave length of the roof below.

#### l. Shed Dormer

- i. A shed dormer is window space with a shed roof that projects perpendicularly from a pitched roof below. Shed dormers provide light and additional HABITABLE space to a half-STORY.

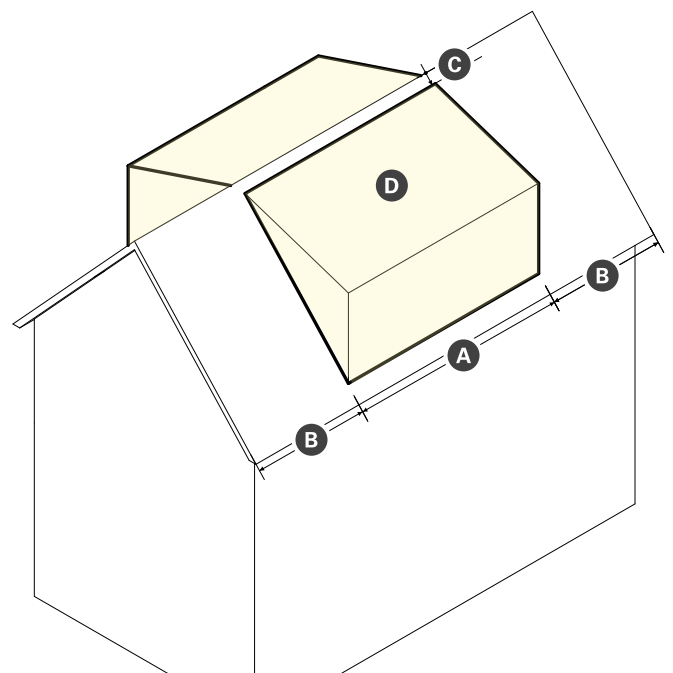

Dimensions	
<b>A</b> Width (max)	window(s) width + 36 in
Side Wall SETBACK (min)	–
Roof with eave	0 ft
Roof without eave	1 ft
<b>B</b> Front & Rear Wall SETBACK (min)	3 ft
<b>C</b> Ridge SETBACK (min)	1 ft
<b>D</b> Roof Slope (min)	4:12 (18.43°)
<b>E</b> Dormer Separation (min)	50% of dormer width

- ii. Standards
  - a). The face wall of a shed dormer may not project beyond the exterior wall of the BUILDING and may not interrupt the eave of the roof.
  - b). Shed dormers may be combined with a dormer window(s) to create a Nantucket dormer.
  - c). The cumulative width of a single, multiple, or attached combinations of dormers may equal up to fifty percent (50%) of the eave length of the roof below.

### 3. RESIDENTIAL DISTRICTS

Neighborhood Residence (NR)

#### m. Cross GABLE

- i. A CROSS GABLE is a sloped roof that projects perpendicularly from the roof of a BUILDING to provide significant additional HABITABLE space to a half-STORY.

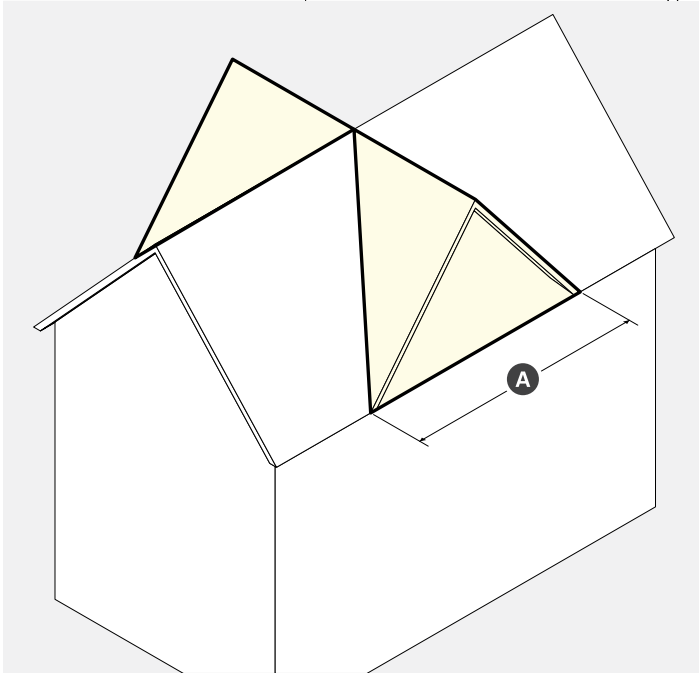

Dimensions	
<b>A</b> Width (max)	Equal to the width of the FACADE or side wall of the BUILDING, which ever is less
FENESTRATION (min)	20%

- ii. Standards
  - a). The ridge and eave of the cross GABLE must be structurally integrated into the ridge and eave of the MAIN ROOF.
  - b). Cross GABLES never have cheek walls.

#### n. Projecting GABLE

- i. A projecting GABLE is an extension of the wall enclosing a pitched roof that expands the size of an attic or the HABITABLE space of a half-STORY.

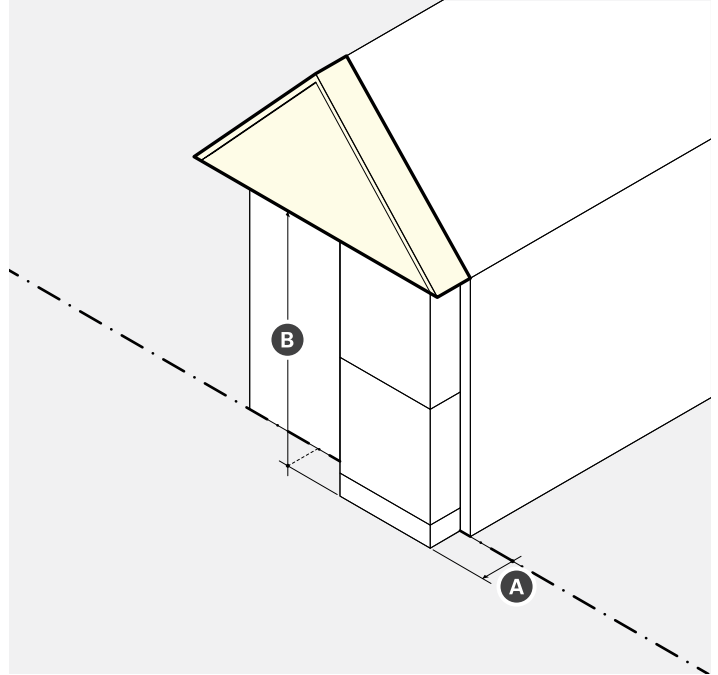

Dimensions	
<b>A</b> Front SETBACK ENCROACHMENT (max)	Same as the furthest projecting Bay or Porch
<b>B</b> CLEARANCE (min)	Height of BUILDING in Stories

- ii. Standards
  - a). A projecting GABLE may extend only forward of the FACADE of a BUILDING.
  - b). A projecting GABLE is permitted only when a Bay or Porch is also present.

### 3. RESIDENTIAL DISTRICTS

Neighborhood Residence (NR)

#### o. Side Wing

- i. A side wing is a multi-STORY extension from one or more side walls of a BUILDING.

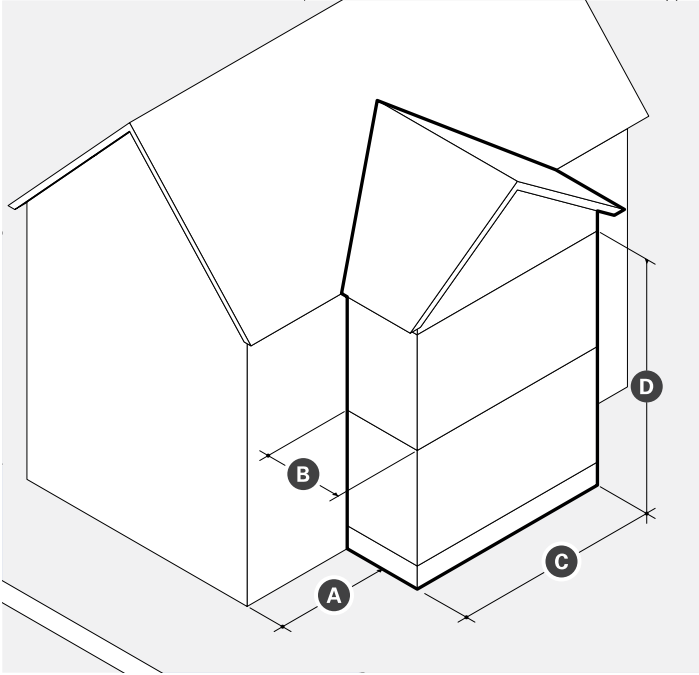

#### p. Rear Addition

- i. A rear addition is an extension from the rear wall of a BUILDING.

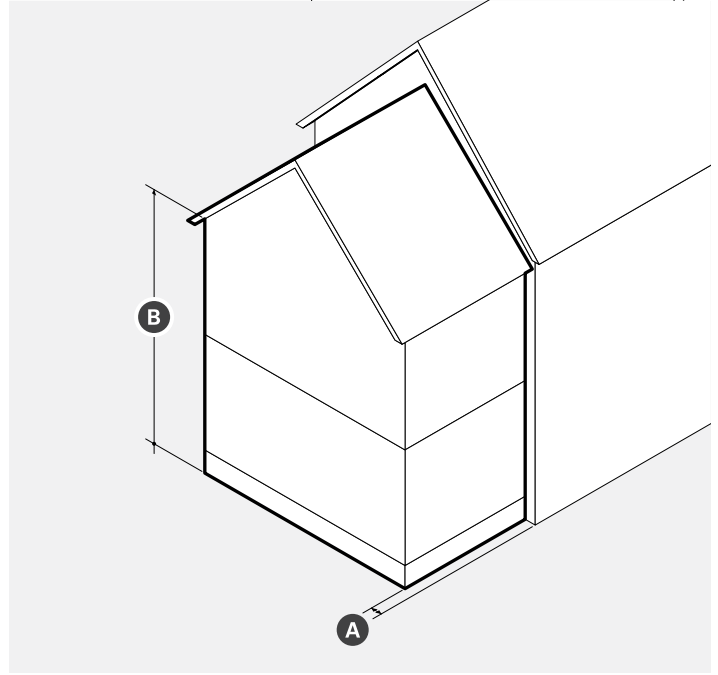

Dimensions	
<b>A</b> SETBACK from FACADE (min)	5 ft
<b>B</b> Width (max)	1/2 of MAIN MASSING Width
<b>C</b> Depth (max)	100% of Main Mass Width
<b>D</b> Height (max)	Same as PRINCIPAL BUILDING
SETBACK ENCROACHMENT (max)	--
Front	0 ft
Side	0 ft
Rear	0 ft

Dimensions	
<b>A</b> SETBACK from Exterior Side Walls (min)	1 ft
FLOOR PLATE (max)	50% of the FLOOR PLATE of the PRINCIPAL BUILDING
<b>B</b> Height (max)	Two (2) Stories
SETBACK ENCROACHMENT (max)	--
Front	0 ft
Side	0 ft
Rear	0 ft

#### ii. Standards

- a). Side wings must include a similarly style roof as the PRINCIPAL BUILDING.

#### ii. Standards

- a). A rear addition may extend only backward from the rear of a BUILDING.
- b). The slope of any pitched roof of a rear addition must be equal to or less than slope of the roof of the MAIN MASS of the BUILDING and no less than nine and one-half degrees (9.5°; 2:12).

# 3. RESIDENTIAL DISTRICTS

Neighborhood Residence (NR)

## 14. Building Design Standards

- a. Contextual Front SETBACKS
  - i. Notwithstanding the front SETBACKS identified for each BUILDING TYPE, new construction must have a contextual front SETBACK as follows:
    - a). If the subject LOT is an INTERIOR LOT OR KEY LOT, the minimum and maximum front SETBACKS are equal to the actual distances that PRINCIPAL STRUCTURES BUILDINGS are set back from the FRONT LOT LINE on the two ABUTTING LOTS of the same BLOCK FACE. See Figure 3.1.14.
    - b). If the subject LOT is a CORNER LOT, the minimum front SETBACK is equal to the actual distance that the PRINCIPAL STRUCTURE BUILDING is set back from the FRONT LOT LINE on the ABUTTING LOT that is oriented toward the same THOROUGHFARE.
    - c). If the LOT on either side of the subject LOT is vacant, the minimum and maximum front SETBACK identified for each BUILDING TYPE governs.
  - ii. The contextual front SETBACK provision does not exempt any BUILDING from complying with the maximum front SETBACK required for each BUILDING TYPE.

**Figure 3.1.14 Contextual Front SETBACK**

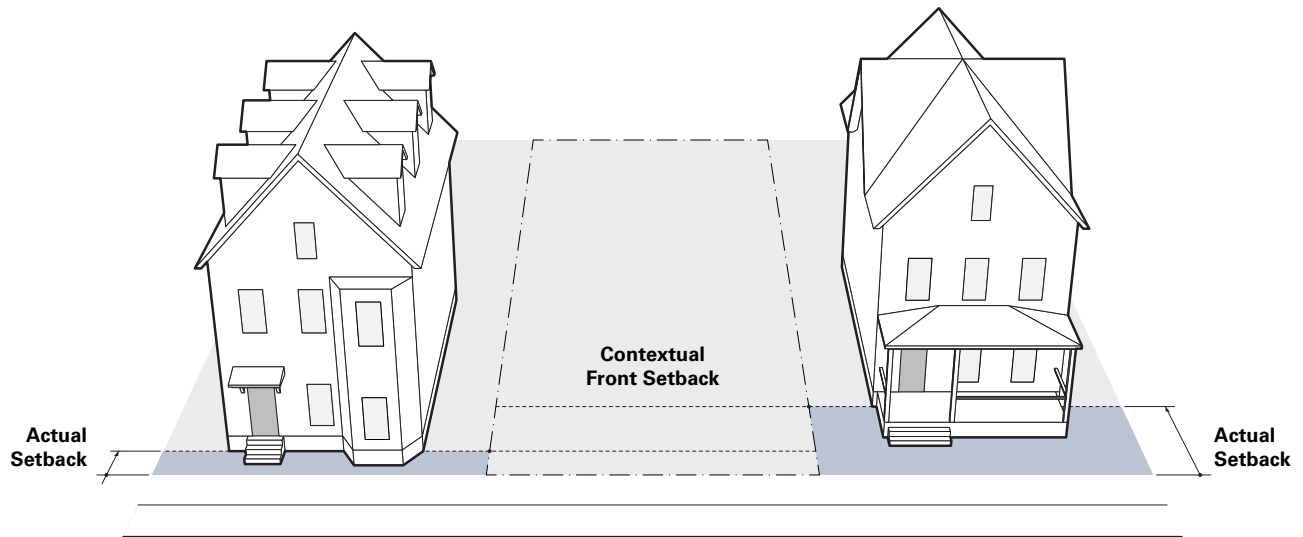

## 15. Architectural Design Guidelines

- a. Privacy
  - i. GROUND STORY DWELLING UNITS should be elevated above the grade of any adjacent sidewalk so that the window sills of the DWELLING UNIT are at or above the eye-level of passing pedestrians. This elevation change maintains privacy for occupants while also encouraging open blinds or curtains to allow natural daylight into the unit.
  - ii. Dormer and sidewall window locations should break the direct line of sight between neighboring properties to every extent practicable. Translucent glass on the bottom half of windows or strategically placed landscape elements should be utilized if it is not practical to off-set windows in such a way as to minimize privacy impacts.
  - iii. Outdoor AMENITY SPACES that are elevated, such as roof DECKS, fully projecting balconies, and UPPER STORY rear porches should, provide sight-obscuring visual screening at the sides to increase privacy, security, and to limit views of ABUTTING properties from elevated vantage points.

Figure 3.1.15 Visual Screening Example



### 3. RESIDENTIAL DISTRICTS

Neighborhood Residence (NR)

#### 16. Use Provisions

- a. General
  - i. The USE of real property is subject to the provisions of Article 9: USE Provisions of this Ordinance. Where the provisions of this section conflict with those of Article 9, the provisions of Article 9 apply.
  - ii. USE categories are permitted as specified on Table 3.1.16.
  - iii. USE categories not identified on Table 3.1.16 are prohibited.
  - iv. All USES must comply with any USE-specific standards applicable for each USE in §9.2 USE Definitions & Limitations.
  - v. USES permitted by Special Permit require additional DEVELOPMENT review in accordance with §15.2.1 Special Permits.
- b. USE Limitations
  - i. Occupancy of a Carriage HOUSE ACCESSORY BUILDING TYPE that is nonconforming to the required minimum side or rear SETBACKS by any permitted Residential PRINCIPAL USE is prohibited.
- c. Adaptive Re-Use of Specific Buildings
  - i. The USE of any PRINCIPAL BUILDING constructed before the adoption date of this Ordinance for a non-residential USE that is considered nonconforming in the Neighborhood Residence district, as established by permit records or other historical documents accepted by the BUILDING OFFICIAL, or any BUILDING USED for municipal operations by the City of Somerville may be changed to any USE within the following PRINCIPAL USE categories in accordance with Table 3.1 (b):
    - a). ARTISINAL PRODUCTION;
    - b). Arts Sales & Services;
    - c). Design SERVICES;
    - d). Shared Workspace & Arts Education;
    - e). CONSUMER GOODS; or
    - f). Fresh Food Market or Grocery.

**Table 3.1.16 Permitted Uses**

Use Category Specific Use	NR
<b>Arts &amp; Creative Enterprise</b>	
Artisinal Production	SP
Arts Sales & Service	SP
Design Services	SP
Shared Workspaces & Arts Education	SP
<b>Auto-Oriented</b>	
Motor Vehicle Parking (as noted below)	--
Off-Site Accessory Parking	SP
<b>Civic &amp; Institutional</b>	
Minor Utility Facility	SP
Public Service	P
Religious & Educational Uses Protected by M.G.L. 40A. Sec. 3	P
<b>Commercial Services</b>	
Day Care Service (as noted below)	--
Child Day Care Center	P
<b>Lodging</b>	
Bed & Breakfast	SP
<b>Residential</b>	
Household Living	P
Group Living (except as follows)	SP
Community or Group Residence	P
Dormitory or Chapter House	N
Homeless Shelter	N
Nursing Home/Assisted Living Facility	N
Rooming House	N

P - Permitted    SP - Special Permit Required    N - Not Permitted



### 3. RESIDENTIAL DISTRICTS

Neighborhood Residence (NR)

**Table 3.1.16 Permitted Uses (continued)**

Use Category Specific Use	NR
<b>Retail Sales</b>	
<b>Consumer Goods (except as follows)</b>	P
Alcohol Sales	N
Firearms Sales	N
Pet Store	N
<b>Fresh Food Market or Grocery Store</b>	P
<b>Urban Agriculture</b>	
<b>Farming (as noted below)</b>	--
Commercial Farming	N
Community Farming	P
<b>Community Gardening</b>	P
<b>Accessory Uses</b>	
<b>Home Occupations (as noted below)</b>	--
Creative Studio	P
Hobby Kennel	SP
Home-Based Business	P
Home-Based Day Care	SP
Home Office	P
<b>Urban Agriculture (as noted below)</b>	--
Apiculture	P
Aviculture	P
Commercial Farming	P
Residential Gardening	P
<b>Vehicle Parking, Accessory (except as follows)</b>	P
Home-Based Business Vehicle Parking	SP

P - Permitted SP - Special Permit Required N - Not Permitted

#### 17. Development Standards

- a. General
  - i. DEVELOPMENT is subject to the provisions of Article 10: DEVELOPMENT Standards of this Ordinance. Where the provisions of this section conflict with those of Article 10, the provisions of Article 10 apply.
- b. SIGNS
  - i. A SIGN, individual numerals or letters, or a nonelectrical nameplate identifying the property address is required for all real property as follows:
    - a). Each GROUND STORY non-residential USE must identify the STREET address either on the PRINCIPAL ENTRANCE door or above or beside the PRINCIPAL ENTRANCE of the USE.
    - b). All residential BUILDING TYPES must identify the STREET address either on the PRINCIPAL ENTRANCE door, above or beside the PRINCIPAL ENTRANCE, or on a mailbox.
  - ii. Address SIGNS must be made easily visible through the USE of colors or materials that contrast with the background material they are attached to and must be conspicuously located to provide visibility from the THOROUGHFARE that the BUILDING faces.
  - iii. Address SIGNS must be twelve (12) inches or less in height and may include the name of the occupant.

# 3. RESIDENTIAL DISTRICTS

Neighborhood Residence (NR)

## 18. Parking & Mobility

- a. General
  - i. DEVELOPMENT is subject to the provisions of Article 11: Parking & Mobility of this Ordinance. Where the provisions of this section conflict with those of Article 11, the provisions of Article 11 apply.
  - ii. Vehicular parking must be provided as specified on Table 3.1.18, except as follows:
    - a). Non-residential uses with five thousand (5,000) square feet or less of GROSS LEASABLE FLOOR AREA are exempt from any minimum requirements of Table 3.1.18.
  - iii. There are no parking requirements for ACCESSORY USES.
  - iv. Parking may be shared between USES on the same LOT and buildings on the same BLOCK in accordance with §11.3 SHARED PARKING.
  - v. DEVELOPMENT outside of a TRANSIT AREA may count one (1) on STREET parking space for every twenty (20) feet of LOT WIDTH toward any minimum parking requirement if residential permit parking is permitted along the same side of the STREET as the LOT that the spaces will serve.
- b. Type
  - i. MOTOR VEHICLE PARKING may be provided as SURFACE PARKING spaces, above ground STRUCTURED PARKING, underground STRUCTURED PARKING, and on STREET parking spaces.
- c. Driveways
  - i. New driveways require a permit from the City Engineer.
  - ii. Driveways must be compliant with all City Ordinances and constructed in accordance with all standards established by relevant City Departments.
  - iii. Driveways are not permitted in the FRONTAGE AREA between a BUILDING and the FRONT LOT LINE.
  - iv. Driveways may be no wider than twelve (12) feet in the FRONTAGE AREA of a LOT.
  - v. Driveways may provide ACCESS in whole or in part on or across an ABUTTING LOT(s), provided that an ACCESS EASEMENT exists between all PROPERTY OWNERS.
  - vi. New driveways should accommodate at least two (2) motor vehicles for every one (1) ON-STREET PARKING SPACE that will be removed as a result of the new driveway.
  - vii. RIBBON DRIVEWAYS and permeable driveways are highly encouraged. See Figure 3.1.18 for examples.
- d. Parking Design
  - i. The design of all parking is subject to §11.1 Bicycle Parking and §11.2 MOTOR VEHICLE PARKING of this Ordinance.
- e. Parking Location
  - i. Required vehicular parking, excluding any required handicapped parking, may be provided on a

**Table 3.1.18 Vehicular Parking**

Use Category Specific Use	BICYCLE		MOTOR VEHICLE	
	Short-Term (min)	Long-Term (min)	Within a TRANSIT AREA <sup>1</sup> (min/max)	Outside of a TRANSIT AREA <sup>1</sup> (min)
<b>Arts &amp; Creative Enterprise Uses</b>				
All Permitted Uses	1.0 / 10,000 sf	1.0 / 3,000 sf	none	1.0 / 1,000 sf
<b>Civic &amp; Institutional</b>				
Religious & Educational Uses Protected by M.G.L. 40A. Sec. 3	none	none	none	none
<b>Lodging Uses</b>				
Bed & Breakfast	none	2.0	none	1.0 / 4 rooms
<b>Residential Uses</b>				
All Permitted Uses	none	none	none	1.0 / DU
<b>Retail Sales Uses</b>				
All Permitted Uses	1.0 / 2,500 sf	1.0 / 10,000 sf	none	1.0 / 1,500 sf

sf - Gross Leasable Square Footage

DU - Dwelling Unit RU - Rooming Unit

<sup>1</sup> See the Transit Area Map

### 3. RESIDENTIAL DISTRICTS

Neighborhood Residence (NR)

contiguous LOT under the same ownership as the LOT that the parking will serve as follows:

- a). Pedestrian ACCESS to off-SITE vehicular parking must be via a paved sidewalk or walkway.
- b). A lease, recorded covenant, or other comparable legal instrument guaranteeing long term USE of the SITE must be provided to the review board or BUILDING OFFICIAL and executed and filed with the Registry of Deeds.
- ii. For real property located in more than one municipality, MOTOR VEHICLE PARKING need not be located within the City of Somerville.
- f. Unbundled Parking
  - i. MOTOR VEHICLE PARKING spaces must be rented or leased as an option rather than a requirement of the rental, lease, or purchase of a DWELLING UNIT or non-residential floor space.
  - ii. Bicycle parking must be provided at no cost or fee to customers, visitors, employees, tenants, and residents.
- g. Parking Relief
  - i. Relief from the parking standards of Table 3.1.18 requires a Special Permit.
    - a). In addition to the review criteria for all Special Permits specified in §15.2.1.e. Review Criteria, the review board shall make findings considering the following in its discretion to approve or deny a special permit authorizing relief from the parking standards of Table 3.1.18:
      - i). The supply and demand of on-STREET

parking in the neighborhood, as determined through a parking study.

- ii). MOBILITY MANAGEMENT programs and services provided by the APPLICANT to reduce the demand for parking.
- iii). That parking provided in excess of any maximum permitted does not result in the increase in impervious LOT AREA.

#### 19. Public Realm

- a. Sidewalk CURB CUTS
  - i. A CURB CUT requires a permit from the City Engineer and must be compliant with all City Ordinances.
  - ii. Unless otherwise specified, the City Engineer may not permit more than one (1) CURB CUT per FRONT LOT LINE of a LOT.
  - iii. CURB CUTS are prohibited along all THOROUGHFARES designated as a PEDESTRIAN STREET.
  - iv. CURB CUTS must be located to minimize conflicts with pedestrians and bicyclists and must have a clear distance from fire hydrants, STREET TREES, utility poles, and other furnishings as deemed necessary by the City Engineer.
    - a). CURB CUTS for commercial or high-volume driveways should be at least one-hundred (100) feet from an UNSIGNALIZED or SIGNALIZED intersection.
    - b). CURB CUTS for residential driveways should be at least twenty (20) feet from an UNSIGNALIZED intersection and at least forty (40) feet from a

Figure 3.1.18 Example Driveways



### 3. RESIDENTIAL DISTRICTS

#### Neighborhood Residence (NR)

SIGNALIZED intersection.

- v. The interior width of a CURB CUT (between curb stones) may be no wider than the driveway, vehicular entrance, or loading facility it serves.
- vi. A DRIVEWAY APRON may be installed only within the furnishing zone of a sidewalk and must be constructed in accordance with all standards established by relevant City Departments.
- vii. The grade, cross slope, and clear width of the walkway of a sidewalk must be maintained between the DRIVEWAY APRON and the ABUTTING driveway. The appearance of the walkway (ie. scoring pattern or paving material) must indicate that, although a vehicle may cross, the area traversed by a vehicle remains part of the sidewalk.

**Figure 3.1.19 Sidewalk Curb Cuts**

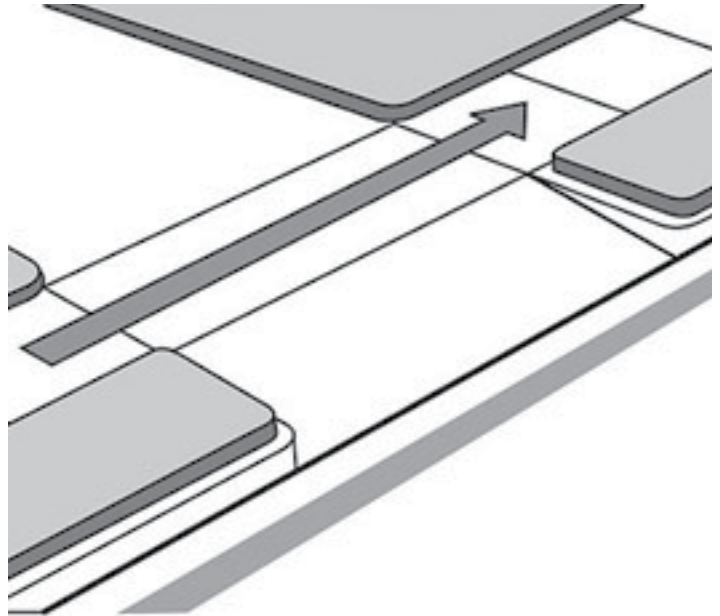



## 3.2 URBAN RESIDENCE (UR)

### 1. Character Description

The Urban Residence district is characterized by a variety of moderate FLOOR PLATE, multi-unit buildings where outdoor AMENITY SPACE is typically shared between the residents of a BUILDING. The district is almost entirely residential, with occasional neighborhood stores, schools, places of worship, and arts related uses on advantageous sites. This district can provide a transition between Neighborhood Residence and the Mid-Rise, HIGH-RISE, and Commercial Districts when mapped accordingly.



## 3. RESIDENTIAL DISTRICTS

### Urban Residence (UR)

#### 2. Intent

- a. To implement the objectives of the COMPREHENSIVE PLAN of the City of Somerville.
- b. To create, maintain, and enhance areas appropriate for multi-unit residential buildings.

#### 3. Purpose

- a. To permit the DEVELOPMENT of multi-unit detached and semi-detached residential buildings on individual LOTS.
- b. To permit contextual MODIFICATIONS to existing detached and semi-detached residential buildings.
- c. To permit the adaptive REUSE of certain existing nonconforming buildings for arts & creative enterprise and retail USES compatible with residential areas.
- d. To create DWELLING UNIT\_types, sizes, and BEDROOM\_counts ideal for both large and small households in permitted BUILDING TYPES.
- e. To permit increased residential density for apartment buildings meeting the definition of a NET ZERO BUILDING or 100% AFFORDABLE HOUSING.

#### 4. Applicability

- a. The section is applicable to all real property within the Urban Residence district as shown on the maps of the Official Zoning Atlas of the City of Somerville.

#### 5. Development Review

- a. DEVELOPMENT review is subject to the provisions of Article 15: Administration of this Ordinance.
- b. All DEVELOPMENT, excluding NORMAL MAINTENANCE, requires the submittal of a development review application to the BUILDING OFFICIAL and the issuance of a Certificate of Zoning Compliance prior to the issuance of a BUILDING Permit or Certificate of Occupancy.
- c. A pre-submittal meeting, in accordance with Article 15: Administration is recommended for all DEVELOPMENT.
- d. Proposed DEVELOPMENT may or may not necessitate the need for Subdivision Plan Approval, Site Plan Approval, a Special Permit, or a Hardship Variance based on the nature of the proposal. In such cases, additional DEVELOPMENT review is required in accordance with Article 15: Administration.
  - i. The Zoning Board of Appeals is the decision making authority for all DEVELOPMENT that requires a Special Permit or HardSHIP Variance in the Urban Residence district.
- e. Upon verification that no additional DEVELOPMENT review is necessary, or completion of the required DEVELOPMENT review, the BUILDING OFFICIAL shall issue a Zoning Compliance Certificate to certify compliance with the provisions and procedures of this Ordinance.

#### 6. Building Types

- a. One (1) PRINCIPAL BUILDING TYPE is permitted on each LOT.
- b. The following PRINCIPAL BUILDING TYPES are permitted in the Urban Residence district:
  - i. Semi-Detached Triple Decker
  - ii. Multi-Plex
  - iii. Apartment House
  - iv. Apartment Building
  - v. Row Houses
- c. ACCESSORY STRUCTURES are regulated according to Article 10: DEVELOPMENT Standards of this Ordinance.



## 3.2.7 Semi-Detached Triple Decker

A moderate FLOOR PLATE, semi-detached, PRINCIPAL BUILDING TYPE with three vertically stacked DWELLING UNITS. A semi-detached triple DECKER must be attached on one side to another semi-detached triple DECKER by a PARTY WALL.

The following images are examples from Somerville of the semi-detached triple DECKER BUILDING TYPE and are intended only for illustrative purposes.



# 3. RESIDENTIAL DISTRICTS

Urban Residence (UR)

## 3.2.7. Semi-Detached Triple Decker (continued)

a. Lot Standards

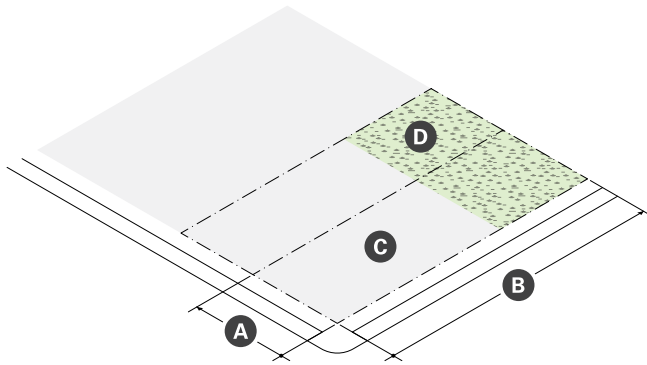

Lot Dimensions	
<b>A</b> LOT WIDTH (min)	--
No Driveway ACCESS	29 ft
Side or Rear Driveway ACCESS	29 ft
Front Driveway ACCESS	32 ft
<b>B</b> LOT DEPTH (min)	80 ft

Lot Development	
<b>C</b> LOT COVERAGE (max)	65%
<b>D</b> GREEN SCORE	--
Minimum	0.35
Ideal	0.40

b. BUILDING Placement

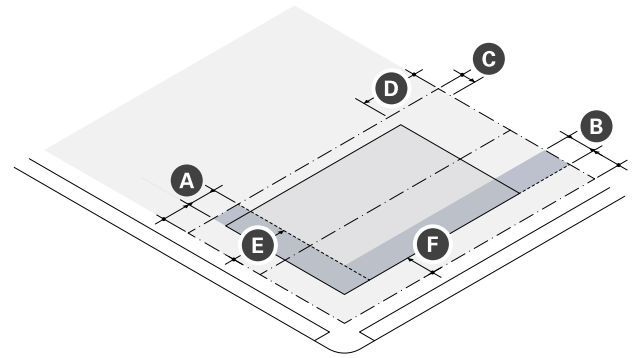

Building Setbacks		
<b>A</b> Primary Front SETBACK <sup>1</sup> (min/max)	10 ft	20 ft
<b>B</b> Secondary Front SETBACK <sup>1</sup> (min/max)	10 ft	20 ft
<b>C</b> Side SETBACK (min)		
PARTY LOT LINE	0 ft	
SIDE LOT LINE	5 ft	
<b>D</b> Rear SETBACK (min)	20 ft	

Parking Setbacks	
<b>E</b> Primary Front SETBACK (min)	20 ft
<b>F</b> Secondary Front SETBACK (min)	10 ft

<sup>1</sup> See §3.2.13.a Contextual Front SETBACKS

## 3.2.7. Semi-Detached Triple Decker (continued)

c. Massing & Height

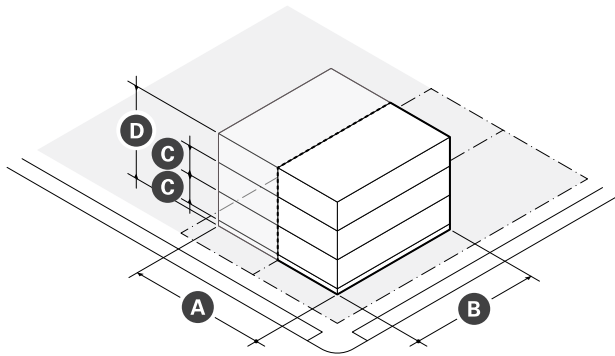

d. Uses & Features

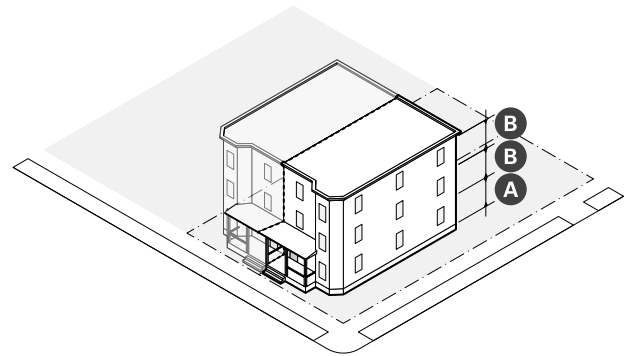

Main Mass	
FACADE Build Out (min)	60%
<b>A</b> Width (min/max)	24 ft 30 ft
<b>B</b> Depth (min/max)	36 ft 50 ft
GROUND STORY Elevation (min)	2 ft
<b>C</b> STORY Height (min/max)	10 ft 12 ft
<b>D</b> Number of Stories (max)	3 stories
Roof Type	Flat

Facade Composition		
<b>A</b> GROUND STORY FENESTRATION (min/max)	20%	50%
<b>B</b> UPPER STORY FENESTRATION (min/max)	20%	50%

Use & Occupancy	
DWELLING UNITS (max)	3
OUTDOOR AMENITY SPACE (min)	1/ DU

# 3. RESIDENTIAL DISTRICTS

Urban Residence (UR)

## 3.2.7. Semi-Detached Triple Decker (continued)

e. Housing

- i. The DWELLING UNITS of a semi-detached triple DECKER must be, generally, stacked one over the other. Common examples are shown in Figure 3.2.7. DWELLING UNITS that are side-by-side or front-to-back in orientation are not permitted.

Figure 3.2.7 Dwelling Unit Orientation

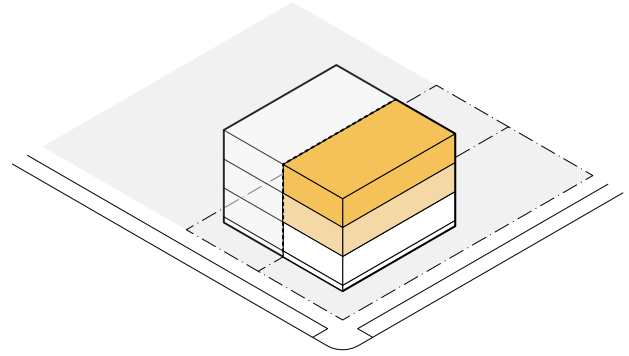



# 3. RESIDENTIAL DISTRICTS

Urban Residence (UR)

## 3.2.8 Multi-Plex

A moderate FLOOR PLATE, detached, PRINCIPAL BUILDING TYPE with four to six DWELLING UNITS.

The following images are examples from Somerville of the multi-plex BUILDING TYPE and are intended only for illustrative purposes.



# 3. RESIDENTIAL DISTRICTS

Urban Residence (UR)

## 3.2.8. Multi-Plex (continued)

a. LOT Standards

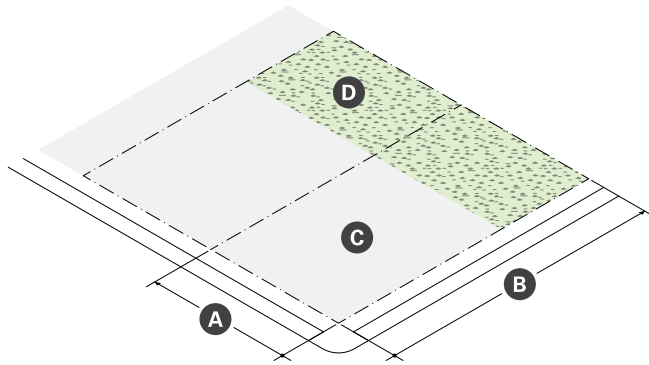

Lot Dimensions	
<b>A</b> LOT WIDTH (min)	--
No Driveway ACCESS	46 ft
Side or Rear Driveway ACCESS	46 ft
Front Driveway ACCESS	49 ft
<b>B</b> LOT DEPTH (min)	85 ft

Lot Development	
<b>C</b> LOT COVERAGE (max)	65%
<b>D</b> GREEN SCORE	--
Minimum	0.35
Ideal	0.40

b. BUILDING Placement

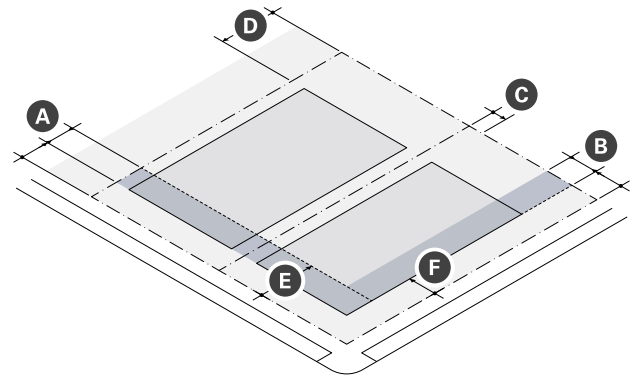

Building Setbacks		
<b>A</b> Primary Front SETBACK <sup>1</sup> (min/max)	10 ft	20 ft
<b>B</b> Secondary Front SETBACK <sup>1</sup> (min/max)	10 ft	20 ft
<b>C</b> Side SETBACK (min)	5 ft	
<b>D</b> Rear SETBACK (min)	20 ft	

Parking Setbacks	
<b>E</b> Primary Front SETBACK (min)	20 ft
<b>F</b> Secondary Front SETBACK (min)	10 ft

<sup>1</sup> See §3.2.13.a Contextual Front SETBACKS



## 3.2.8. Multi-Plex (continued)

c. Massing & Height

d. Uses & Features

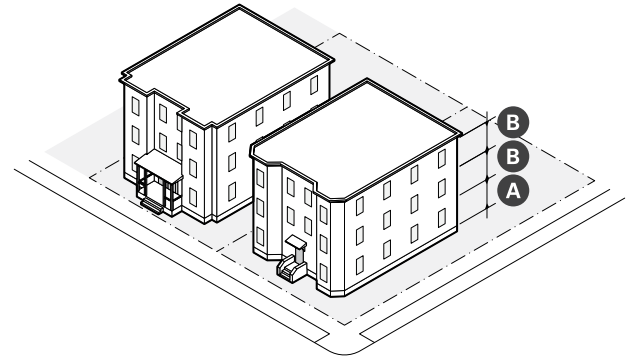
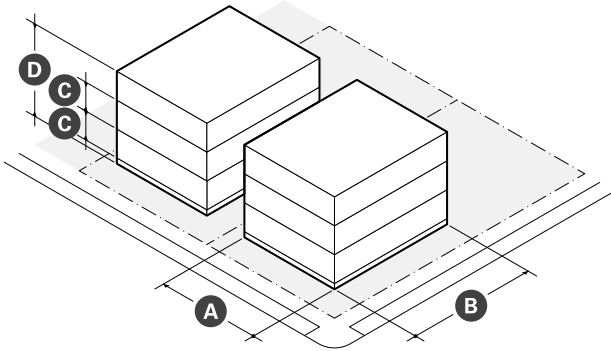

Main Mass	
FACADE Build Out (min)	70%
<b>A</b> Width (min/max)	36 ft 50 ft
<b>B</b> Depth (min/max)	44 ft 64 ft
GROUND STORY Elevation (min)	2 ft
<b>C</b> STORY Height (min/max)	10 ft 12 ft
<b>D</b> Number of Stories (max)	3 stories
Roof Type	Flat, GABLE, HIP

Facade Composition		
<b>A</b> GROUND STORY FENESTRATION (min/max)	20%	50%
<b>B</b> UPPER STORY FENESTRATION (min/max)	20%	50%

Use & Occupancy	
DWELLING UNITS (min/max)	4 6
Outdoor AMENITY SPACE (min)	1/ DU

# 3. RESIDENTIAL DISTRICTS

Urban Residence (UR)

## 3.2.8. Multi-Plex (continued)

- e. Housing
  - i. The DWELLING UNITS of a multi-plex must be, generally, stacked one over the other. Common examples are shown in Figure 3.2.8. DWELLING UNITS that are front-to-back in orientation are not permitted.

Figure 3.2.8 Dwelling Unit Orientation

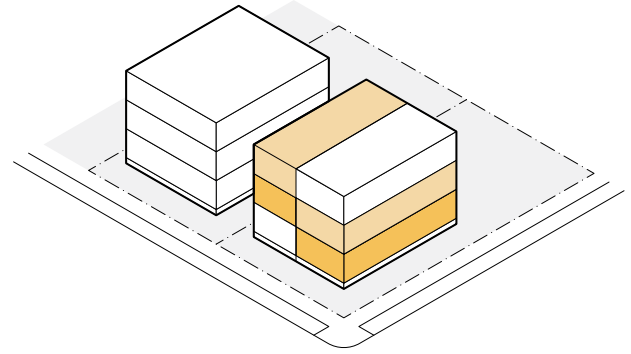

## 3.2.9 Apartment House

A moderate FLOOR PLATE, detached, PRINCIPAL BUILDING TYPE with six to ten DWELLING UNITS designed to appear as a large HOUSE.

The following images are primarily examples from Somerville of the apartment house BUILDING TYPE and are intended only for illustrative purposes.



# 3. RESIDENTIAL DISTRICTS

Urban Residence (UR)

## 3.2.9 Apartment House (continued)

a. LOT Standards

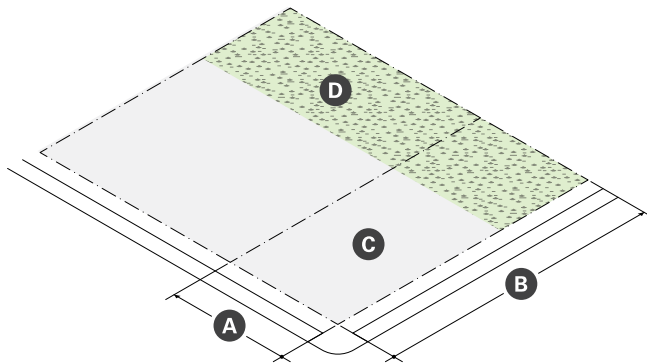

b. BUILDING Placement

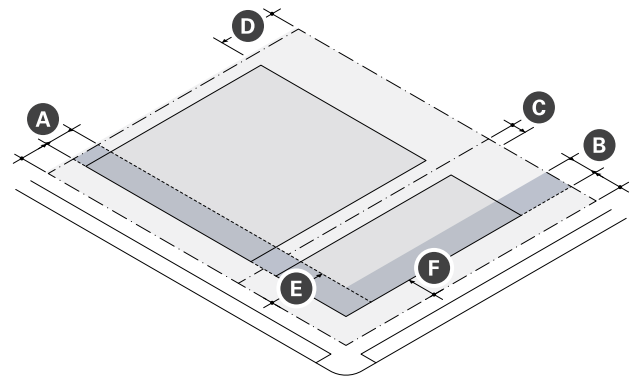

### Lot Dimensions

<b>A</b> LOT WIDTH (min)	--
No Driveway ACCESS	38 ft
Side or Rear Driveway ACCESS	38 ft
Front Driveway ACCESS	41 ft
<b>B</b> LOT DEPTH (min)	100 ft

### Lot Development

<b>C</b> LOT Coverage (max)	65%
<b>D</b> GREEN SCORE	--
Minimum	0.35
Ideal	0.40

### Building Setbacks

<b>A</b> Primary Front SETBACK <sup>1</sup> (min/max)	10 ft 20 ft
<b>B</b> Secondary Front SETBACK <sup>1</sup> (min/max)	10 ft 20 ft
<b>C</b> Side SETBACK (min)	5 ft
<b>D</b> Rear SETBACK (min)	20 ft

### Parking Setbacks

<b>E</b> Primary Front SETBACK (min)	20 ft
<b>F</b> Secondary Front SETBACK (min)	10 ft

<sup>1</sup> See §3.2.13.a Contextual Front SETBACKS

## 3.2.9 Apartment House (continued)

c. Massing & Height

d. Uses & Features

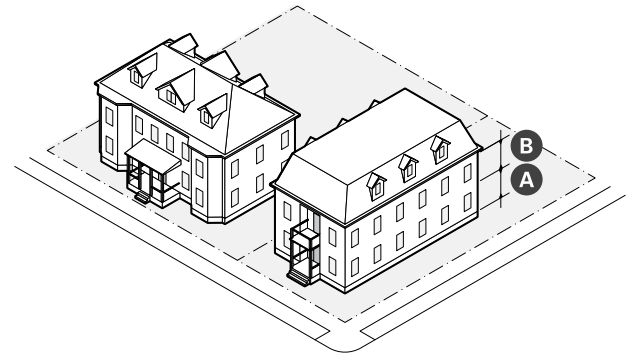
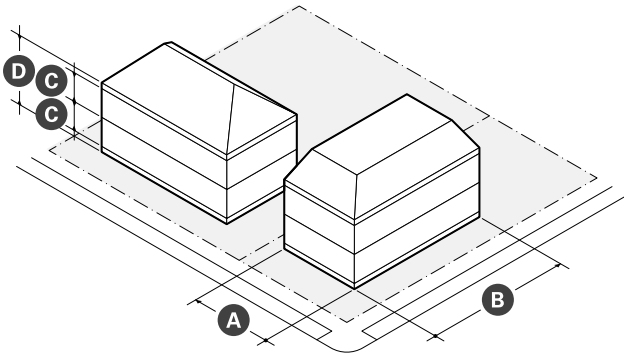

Main Mass	
FACADE Build Out (min)	70%
<b>A</b> Width (min/max)	28 ft 56 ft
<b>B</b> Depth (min/max)	44 ft 68 ft
GROUND STORY Elevation (min)	2 ft
<b>C</b> STORY Height (min/max)	10 ft 12 ft
<b>D</b> Number of Stories (max)	2.5 stories
Roof Type	GABLE, HIP, MANSARD

Facade Composition		
<b>A</b> GROUND STORY FENESTRATION (min/max)	20%	50%
<b>B</b> UPPER STORY FENESTRATION (min/max)	20%	50%

Use & Occupancy		
DWELLING UNITS (min/max)	4	10
Outdoor AMENITY SPACE (min)	1/ DU	

# 3. RESIDENTIAL DISTRICTS

Urban Residence (UR)

## 3.2.9 Apartment House (continued)

- e. Housing
  - i. Reserved
- f. DEVELOPMENT Benefits
  - i. DEVELOPMENT is subject to the provisions of Article 12: DEVELOPMENT Benefits of this Ordinance. Where the provisions of this section conflict with those of Article 12, the provisions of Article 12 apply.
  - ii. DEVELOPMENT of an apartment house must provide AFFORDABLE DWELLING UNITS as specified on Table 3.2.9.

**Table 3.2.9 Required ADUs**

Total DWELLING UNITS	Required ADUs
0 to 5 units	None
6 units	1 unit OR fractional buyout for 0.4 units
7 units	1 unit OR fractional buyout for 0.6 units
8 to 10 units	17.5% of units



## 3.2.10 Apartment Building

A moderate FLOOR PLATE, multi-STORY PRINCIPAL BUILDING TYPE with multiple DWELLING UNITS primarily ACCESSED from a single PRINCIPAL ENTRANCE and interior hallway or stairway.

The following images are examples of the apartment BUILDING TYPE and are intended only for illustrative purposes.



# 3. RESIDENTIAL DISTRICTS

Urban Residence (UR)

## 3.2.10 Apartment Building (continued)

a. LOT Standards

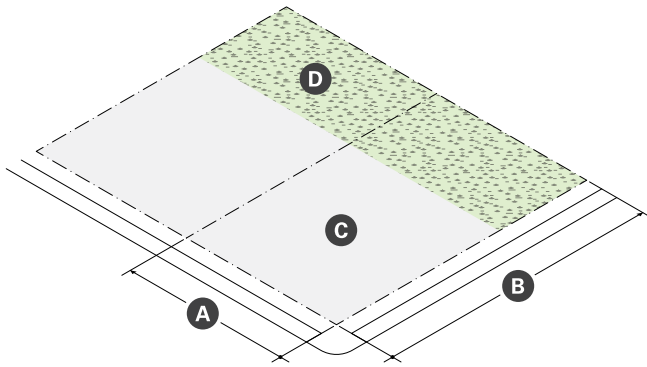

b. BUILDING Placement

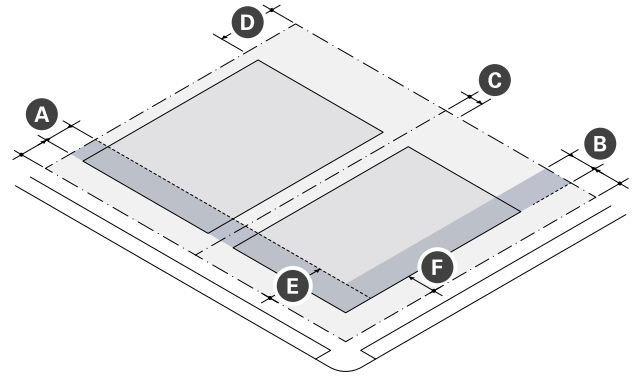

Lot Dimensions	
<b>A</b> LOT WIDTH (min)	--
No Driveway ACCESS	55 ft
Side or Rear Driveway ACCESS	55 ft
Front Driveway ACCESS	58 ft
<b>B</b> LOT DEPTH (min)	90 ft

Lot Development	
<b>C</b> LOT COVERAGE (max)	65%
<b>D</b> GREEN SCORE	--
Minimum	0.35
Ideal	0.40

Building Setbacks		
<b>A</b> Primary Front SETBACK <sup>1</sup> (min/max)	10 ft	20 ft
<b>B</b> Secondary Front SETBACK <sup>1</sup> (min/max)	10 ft	20 ft
<b>C</b> Side SETBACK (min)	5 ft	
Side SETBACK ABUTTING NR (min)	20 ft	
<b>D</b> Rear SETBACK (min)	10 ft	
Rear SETBACK ABUTTING NR (min)	20 ft	

Parking Setbacks		
<b>E</b> Primary Front SETBACK (min)	--	
SURFACE PARKING	20 ft	
STRUCTURED PARKING	20 ft	
<b>F</b> Secondary Front SETBACK (min)	--	
SURFACE PARKING	10 ft	
STRUCTURED PARKING	10 ft	

<sup>1</sup> See §3.2.13.a Contextual Front SETBACKS

## 3.2.10 Apartment Building (continued)

### c. Massing & Height

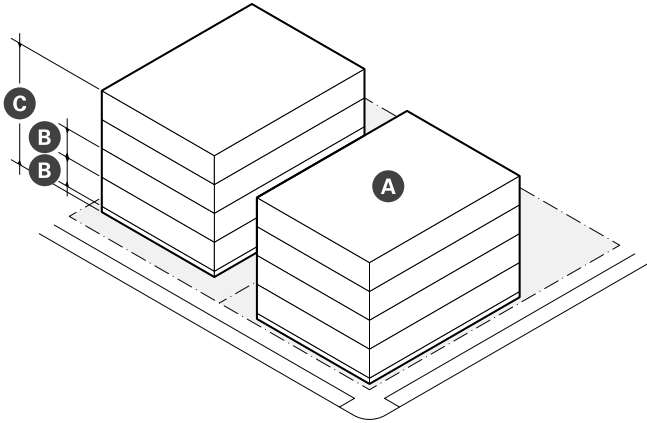

### d. Uses & Features

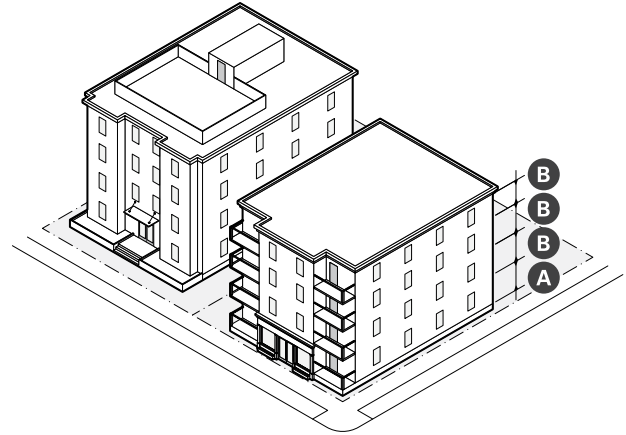

Main Mass	
FACADE Build Out (min)	80%
<b>A</b> FLOOR PLATE (max)	--
with FORECOURT	16,000 sf
without a FORECOURT	7,000 sf
GROUND STORY Elevation (min)	2 ft
<b>B</b> STORY Height (min/max)	10 ft 12 ft
<b>C</b> Number of Stories (min)	2 4
Roof Type	Flat, MANSARD

Facade Composition		
<b>A</b> GROUND STORY FENESTRATION (min/max)	20%	50%
<b>B</b> UPPER STORY FENESTRATION (min/max)	20%	50%

Use & Occupancy	
GROSS FLOOR AREA per DU (min)	--
LOT AREA < 5,000 sf	1,500
LOT AREA >= 5,000 sf	1,125
100% AFFORDABLE HOUSING	875
NET ZERO BUILDING	875
Outdoor AMENITY SPACE (min)	1/DU

# 3. RESIDENTIAL DISTRICTS

Urban Residence (UR)

## 3.2.10 Apartment Building (continued)

- e. Housing
  - i. Reserved
- f. DEVELOPMENT Benefits
  - i. DEVELOPMENT is subject to the provisions of Article 12: DEVELOPMENT Benefits of this Ordinance. Where the provisions of this section conflict with those of Article 12, the provisions of Article 12 apply.
  - ii. DEVELOPMENT of an apartment building must provide AFFORDABLE DWELLING UNITS as specified on Table 3.2.10.

**Table 3.2.10 Required ADUs**

Total DWELLING UNITS	Required ADUs
0 to 5 units	None
6 units	1 unit OR fractional buyout for 0.4 units
7 units	1 unit OR fractional buyout for 0.6 units
8 to 17 units	17.5% of units
18 or more units	20% of units



# 3. RESIDENTIAL DISTRICTS

Urban Residence (UR)

## 3.2.11 Row Houses

A moderate floorplate, multi-STORY, PRINCIPAL BUILDING TYPE designed as series of three (3) or more small FLOOR PLATE, attached, residential buildings, each with one (1) DWELLING UNIT.

The following images are examples from Somerville of the row houses BUILDING TYPE and are intended only for illustrative purposes.



# 3. RESIDENTIAL DISTRICTS

Urban Residence (UR)

## 3.2.11 Row Houses (continued)

a. LOT Standards

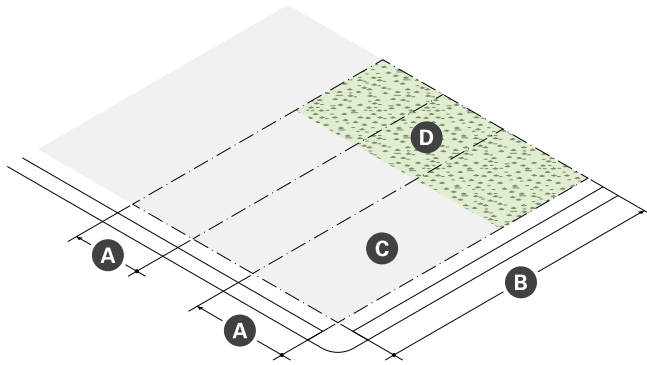

SITE Dimensions	
Width (min/max)	82 ft 250 ft

Lot Dimensions	
<b>A</b> LOT WIDTH (min)	--
INTERIOR LOT in Sequence	--
No Driveway ACCESS	24 ft
End LOT in Sequence	--
No Driveway ACCESS	29 ft
Side or Rear Driveway ACCESS	29 ft
Front Driveway ACCESS	32 ft
<b>B</b> LOT DEPTH (min)	80 ft

Lot Development	
<b>C</b> LOT Coverage (max)	65%
<b>D</b> GREEN SCORE	--
Minimum	0.35
Ideal	0.40

b. BUILDING Placement

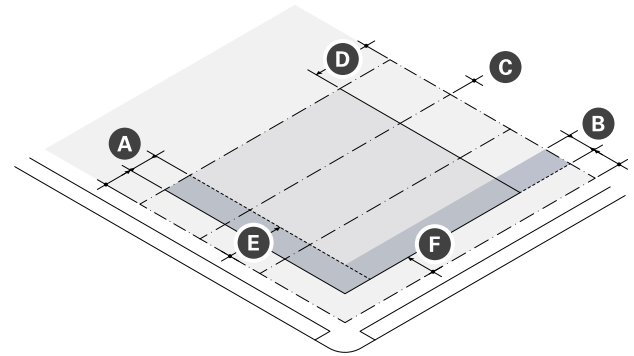

Building Setbacks	
<b>A</b> Primary Front SETBACK <sup>1</sup> (min/max)	10 ft 20 ft
<b>B</b> Secondary Front SETBACK <sup>1</sup> (min/max)	10 ft 20 ft
<b>C</b> Side SETBACK (min)	5 ft
PARTY LOT LINE	0 ft
SIDE LOT LINE	5 ft
<b>D</b> Rear SETBACK (min)	20 ft

Parking Setbacks	
<b>E</b> Primary Front SETBACK (min)	20 ft
<b>F</b> Secondary Front SETBACK (min)	10 ft

<sup>1</sup> See §3.2.13.a Contextual Front SETBACKS



## 3.2.11 Row Houses (continued)

c. Massing & Height

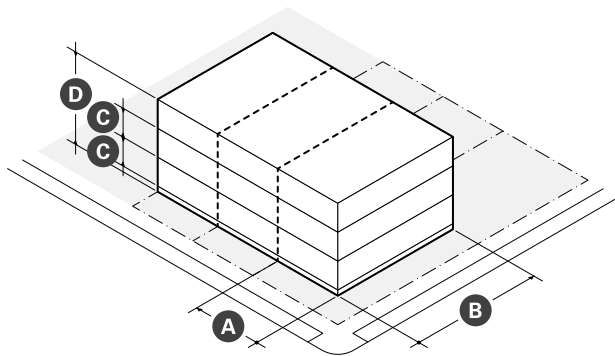

d. Uses & Features

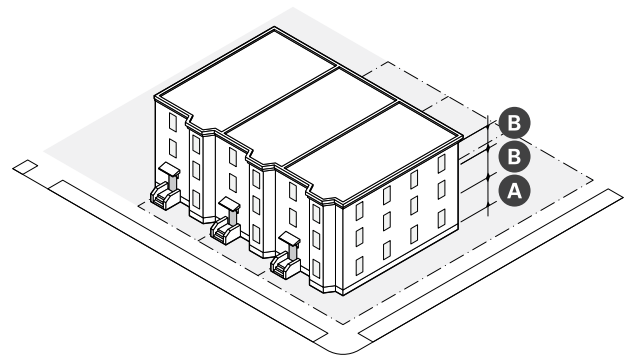

Main Mass	
FACADE Build Out (min)	70%
<b>A</b> Width per Rowhouse (min/max)	24 ft 30 ft
<b>B</b> Depth (min/max)	34 ft 60 ft
Rowhouses in Sequence (min/max)	3   10
GROUND STORY Elevation (min)	2 ft
<b>C</b> STORY Height (min/max)	10 ft 12 ft
<b>D</b> Number of Stories (min)	2 stories
Roof Type	Flat, GABLE, MANSARD

Facade Composition		
<b>A</b> GROUND STORY FENESTRATION (min/max)	20%	50%
<b>B</b> UPPER STORY FENESTRATION (min/max)	20%	50%

Use & Occupancy		
DWELLING UNITS per SITE (min/max)	3	10
DWELLING UNITS per Row House (max)	1	
Outdoor AMENITY SPACE (min)	1/ DU	

# 3. RESIDENTIAL DISTRICTS

Urban Residence (UR)

## 3.2.11 Row Houses (continued)

- e. Housing
  - i. Reserved
- f. DEVELOPMENT Benefits
  - i. DEVELOPMENT is subject to the provisions of Article 12: DEVELOPMENT Benefits of this Ordinance. Where the provisions of this section conflict with those of Article 12, the provisions of Article 12 apply.
  - ii. DEVELOPMENT of row HOUSES must provide AFFORDABLE DWELLING UNITS as specified on Table 3.2.11.

**Table 3.2.11 Required ADUs**

Total DWELLING UNITS	Required ADUs
0 to 5 units	None
6 units	1 unit OR fractional buyout for 0.4 units
7 units	1 unit OR fractional buyout for 0.6 units
8 to 10 units	17.5% of units

### 3. RESIDENTIAL DISTRICTS

Urban Residence (UR)

#### 12. Building Components

- a. BUILDING COMPONENTS are ACCESSORY elements attached to the main mass of a PRINCIPAL BUILDING.
- b. BUILDING COMPONENTS are permitted as specified on Table 3.2.12.
- c. BUILDING COMPONENTS not identified on Table 3.2.12 are prohibited.
- d. Unless otherwise specified, BUILDING COMPONENTS may attach to other BUILDING COMPONENTS to create assemblies of components.

**Table 3.2.12 Building Components**

	<b>Semi-Detached Triple Decker</b>	<b>Multi-Plex</b>	<b>Apartment HoUSE</b>	<b>Apartment BUILDING</b>	<b>RowhoUSES</b>
Entry Canopy	P	P	P	P	P
Stoop	P	P	P	P	P
Portico	P	P	P	P	P
Projecting Porch	P	P	P	P	P
Lobby Entrance	N	N	N	P	N
Bay	P	P	P	P	P
Balcony	N	P	P	P	P
Dormer	N	Y	Y	N	Y
Shed Dormer	N	Y	Y	N	N
Cross GABLE	N	Y	Y	N	N

P - Permitted    SP - Special Permit Required    N - Not Permitted

### 3. RESIDENTIAL DISTRICTS

Urban Residence (UR)

#### e. Entry Canopy

- i. An entry canopy is a wall-mounted STRUCTURE that provides shade and weather protection over the entrance of a BUILDING.

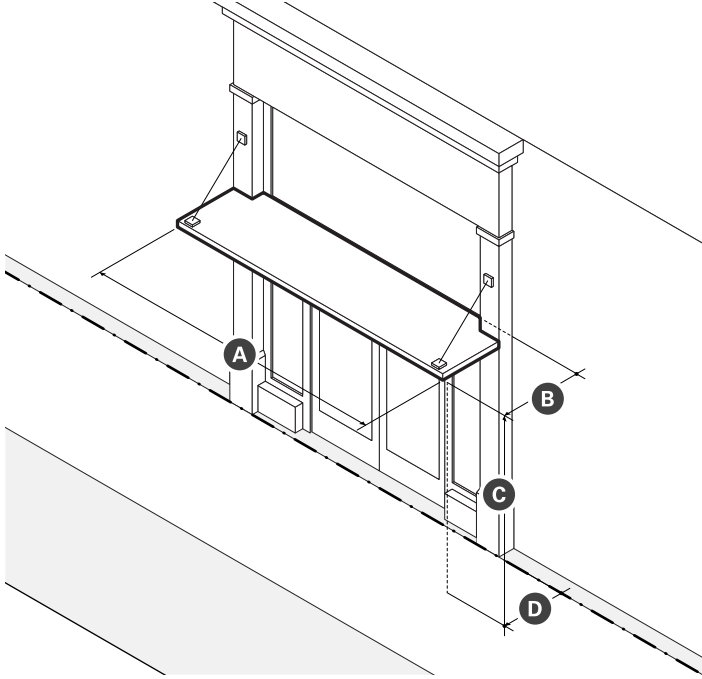

Dimensions	
<b>A</b> Width (min)	See §D.ii.b
<b>B</b> Depth (max)	3 ft
<b>C</b> CLEARANCE (min)	8 ft clear
<b>D</b> SETBACK ENCROACHMENT (max)	--
Front	100%
Side	0 ft
Rear	0 ft

- ii. Standards
  - a). Entry canopies must be visually supported by brackets, cables, or rods.
  - b). The width of an entry canopy must be equal to or greater than the width of the doorway surround or exterior casing it is mounted over.

#### f. Stoop

- i. A stoop is a frontage type featuring a set of stairs with a landing leading to the entrance of a BUILDING.

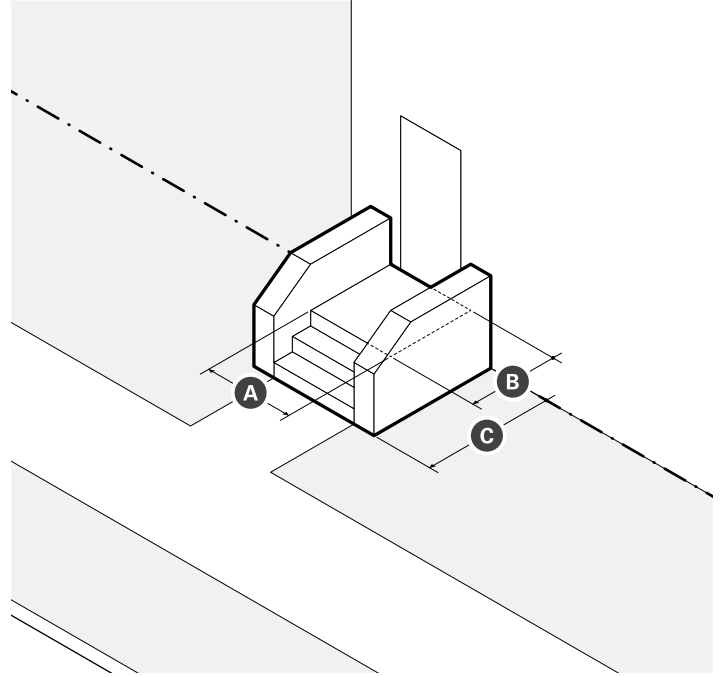

Dimensions	
<b>A</b> Landing Width (min)	4 ft
<b>B</b> Landing Depth (min)	4 ft
<b>C</b> SETBACK ENCROACHMENT (max)	--
Front	100%
Side	0 ft
Rear	0 ft

- ii. Standards
  - a). Stairs may be recessed into the BUILDING FACADE when the BUILDING is set back four (4) feet or less.
  - b). Stairs are not permitted to ENCROACH onto any ABUTTING sidewalk.
  - c). Stairs may be built perpendicular or parallel to the BUILDING FACADE, but must lead directly to ground level or an ABUTTING sidewalk.

## g. Portico

- i. A portico is a frontage type featuring a set of stairs with a landing leading to the entrance of a BUILDING and a roof supported by columns, PIERS, or posts.

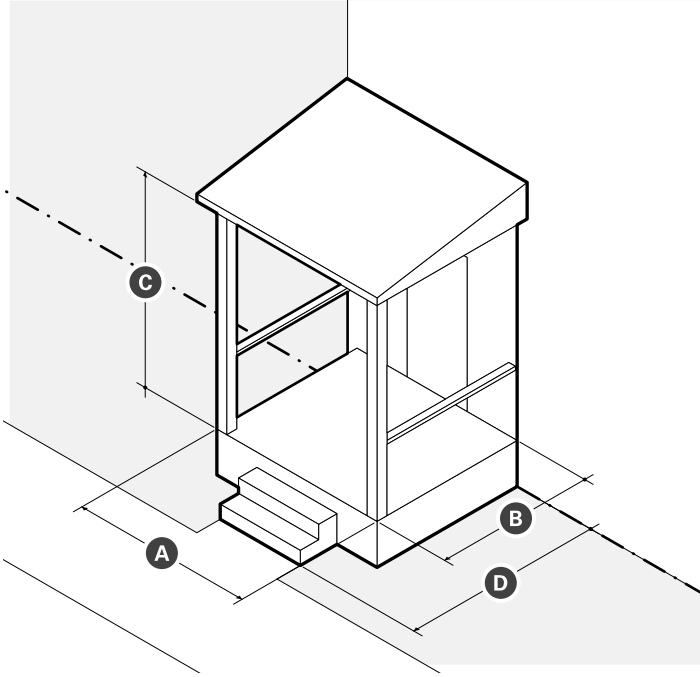

Dimensions	
<b>A</b> Landing Width (min)	4 ft
<b>B</b> Landing Depth (max)	4 ft
<b>C</b> CLEARANCE (max)	8 ft
<b>D</b> SETBACK ENCROACHMENT (max)	--
Front	100%
Side	0 ft
Rear	0 ft

- ii. Standards
  - a). Stairs are not permitted to ENCROACH onto any ABUTTING sidewalk.
  - b). Stairs may be built perpendicular or parallel to the BUILDING FACADE, but must lead directly to ground level or an ABUTTING sidewalk.

## h. Projecting Porch

- i. A projecting porch is a frontage type featuring a set of stairs with a landing leading to the entrance of a BUILDING and a roof supported by columns, PIERS, or posts.

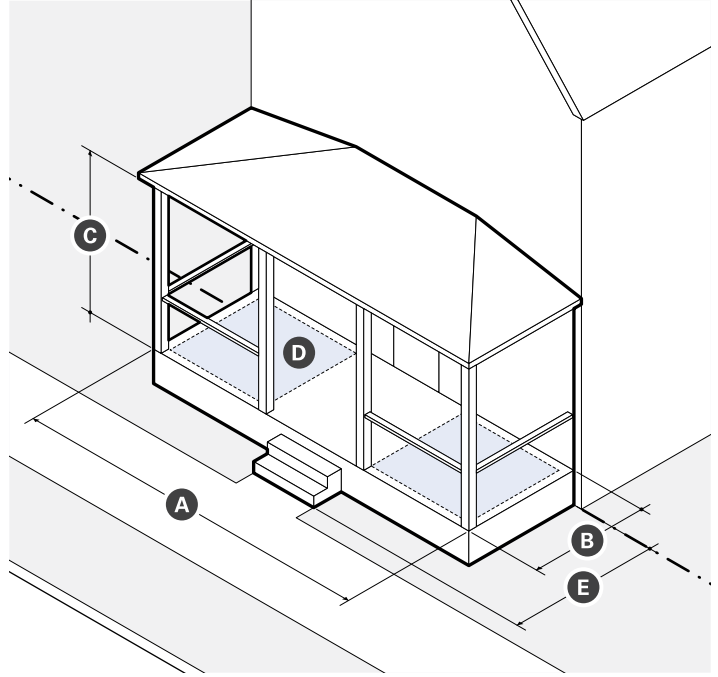

Dimensions	
<b>A</b> Width (min)	10' or 50% of FACADE width, whichever is greater
<b>B</b> Depth (min)	6 ft
<b>C</b> CLEARANCE (min)	8 ft
<b>D</b> FURNITURE AREA, Clear (min)	6 ft x 6 ft
<b>E</b> SETBACK ENCROACHMENT (max)	--
Front	100%
Side	0 ft
Rear	0 ft

- ii. Standards
  - a). Stairs are not permitted to ENCROACH onto any ABUTTING sidewalk.
  - b). Porch railings must permit visual supervision of the PUBLIC REALM through the posts and rails.
  - c). A porch may be screened provided the percentage of window area to wall area is seventy percent (70%) or greater. Permanent enclosure of a porch to create year-round living space is not permitted.

# 3. RESIDENTIAL DISTRICTS

Urban Residence (UR)

## i. Lobby Entrance

- i. A lobby entrance frontage type featuring an at-grade PRINCIPAL ENTRANCE providing ACCESS TO UPPER STORY USES of a BUILDING.

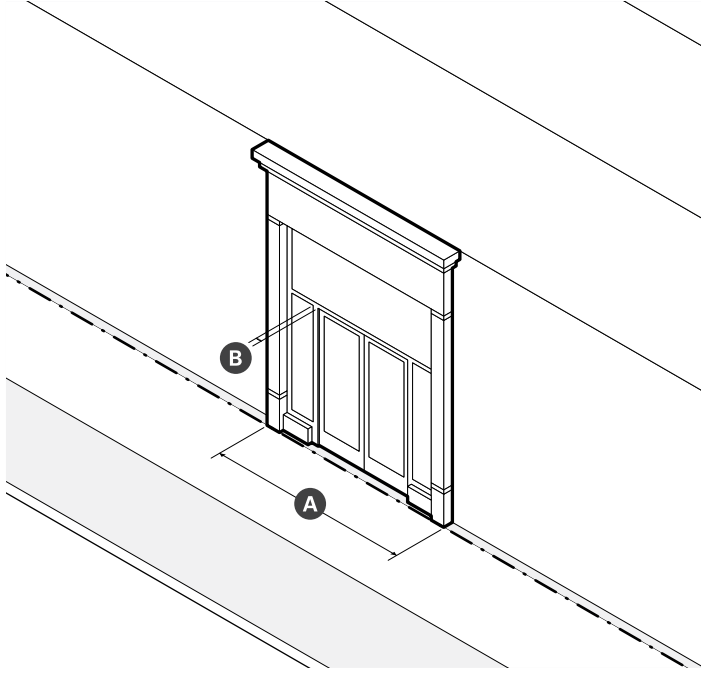

Dimensions	
<b>A</b> Width (max)	30 ft
<b>B</b> Recessed Entrance Width (max)	15 ft
Recessed Entrance Depth (max)	5 ft

- ii. Standards
  - a). Lobby entrances must be well-defined, clearly visible, and universally ACCESSIBLE from the ABUTTING sidewalk.
  - b). Lobby entrances should be made clearly identifiable using a difference in design from the rest of the FACADE.
  - c). Lobby entrances must include an awning or entry canopy above the PRINCIPAL ENTRANCE to provide weather protection.
  - d). When a lobby entrance is set back from the FRONT LOT LINE, the frontage must be paved to match the ABUTTING sidewalk.

## j. Bay Window

- i. A bay window is an assembly of windows projecting from a building to provide additional HABITABLE space, increased light, multi-directional views, and ARTICULATION to an exterior wall.

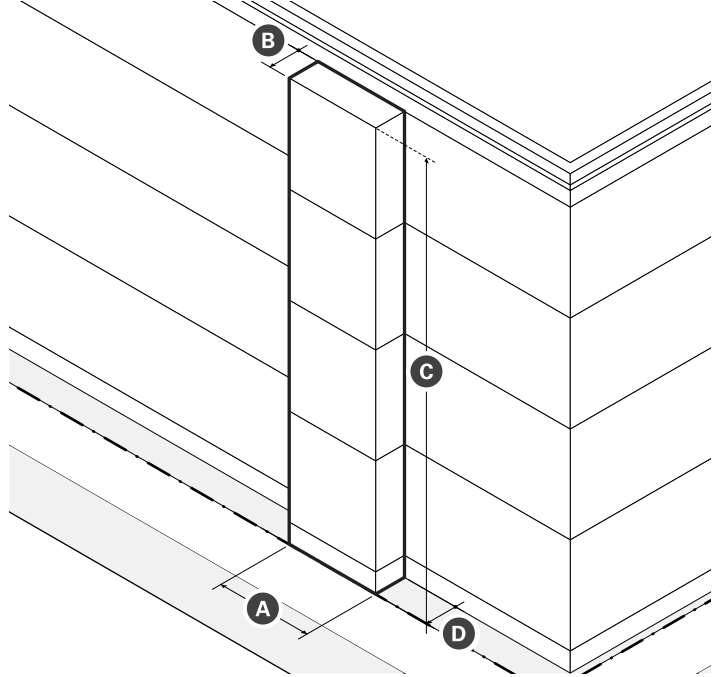

Dimensions	
<b>A</b> Width (max)	16 ft
<b>B</b> Projection (max)	3 ft
<b>C</b> Height (max)	Height of BUILDING in Stories
<b>D</b> SETBACK ENCROACHMENT (max)	-
Front	3 ft
Side	0 ft
Rear	0 ft

- ii. Standards
  - a). Bay windows, including box and bow windows, must include at least three (3) windows.
  - b). The cumulative width of multiple bays may equal up to fifty percent (50%) of the width of the exterior wall from which the bays project.
  - c). Bays projecting over the sidewalk of a public THOROUGHFARE must have at least two (2) stories of CLEARANCE and be compliant with all City Ordinances.



## k. Balcony

- i. A balcony is a platform with a railing that provides outdoor AMENITY SPACE.

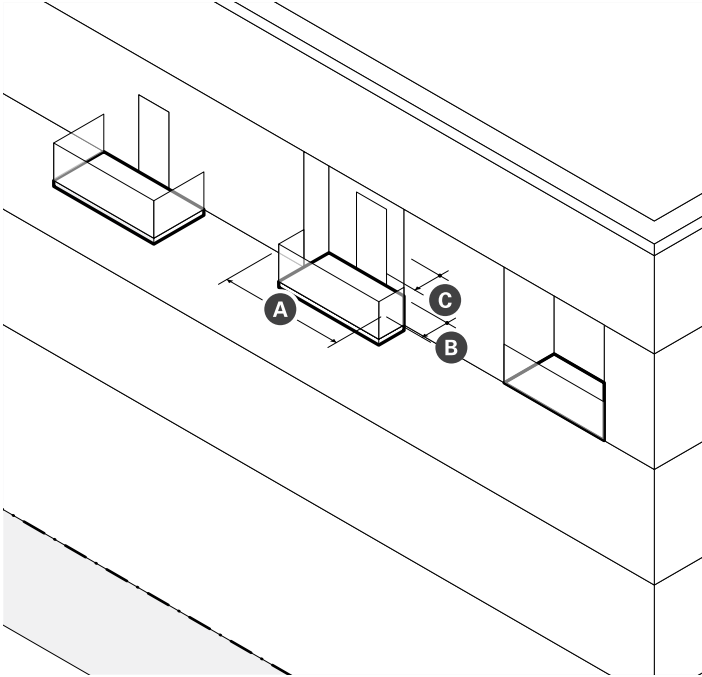

Dimensions	
<b>A</b> Width (min)	5 ft
<b>B</b> Depth (min)	5 ft
Area (min)	50 sf
CLEARANCE (min)	10 ft
<b>C</b> SETBACK ENCROACHMENT (max)	--
Front	100%
Side	0 ft
Rear	0 ft

- ii. Standards
  - a). Balconies may be recessed, projecting, a combination of the two, or terraced as part of the roof of a portico, porch, or bay.
  - b). Balconies that project over any public sidewalk requires compliance with all City Ordinances.
  - c). Front balconies must permit visual supervision of the PUBLIC REALM through the posts and rails. Side and rear balconies ABUTTING the NR district must include sight-obscuring visual screening so that it is at least fifty percent (50%) opaque.

## l. Dormer

- i. A dormer is a window space with a GABLE, HIP, or arched roof that projects perpendicularly from a pitched roof below. Dormer windows provide light to the HABITABLE space of a half-STORY.

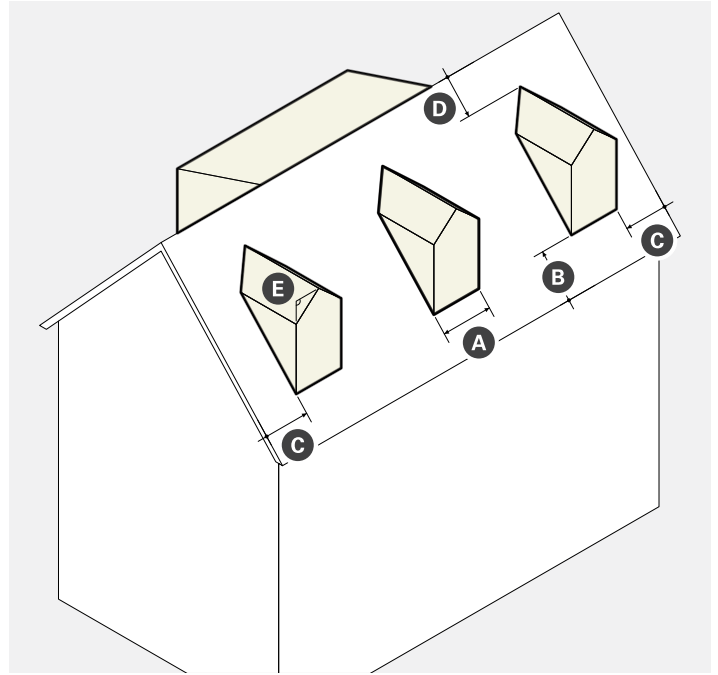

Dimensions	
<b>A</b> Width (max)	window(s) width + 18 in
Side Wall SETBACK (min)	--
Roof with eave	0 ft
Roof without eave	1 ft
<b>B</b> Front & Rear Wall SETBACK (min)	3 ft
<b>C</b> Ridge SETBACK (min)	1 ft
<b>D</b> Roof Slope (min)	4:12 (18.43°)
<b>E</b> Dormer Separation (min)	50% of dormer width

- ii. Standards
  - a). The face wall of a dormer window may not project beyond the exterior wall of the BUILDING and may not interrupt the eave of the roof.
  - b). Dormer windows may be combined with a shed dormer(s) to create a Nantucket dormer.
  - c). The cumulative width of a single, multiple, or attached combinations of dormers may equal up to fifty percent (50%) of the eave length of the roof below.

### 3. RESIDENTIAL DISTRICTS

Urban Residence (UR)

#### m. Shed Dormer

- i. A shed dormer is window space with a shed roof that projects perpendicularly from a pitched roof below. Shed dormers provide light and additional HABITABLE space to a half-STORY.

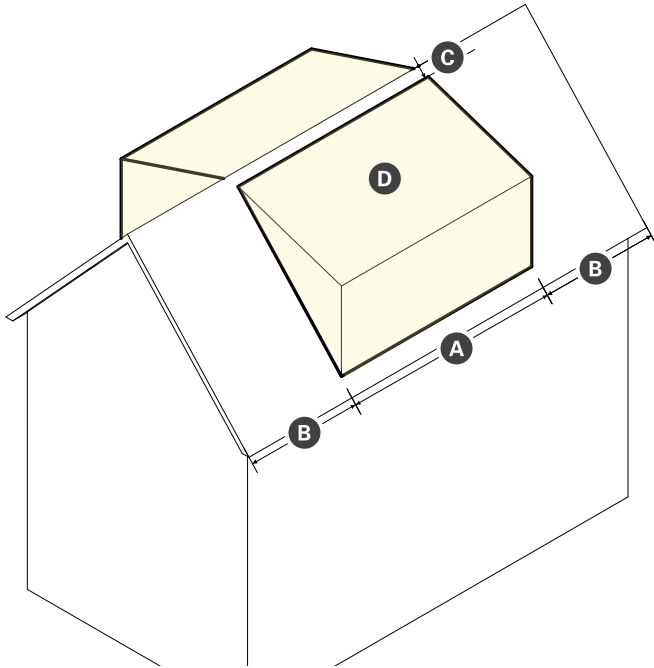

Dimensions	
<b>A</b> Width (max)	window(s) width + 36 in
Side Wall SETBACK (min)	–
Roof with eave	0 ft
Roof without eave	1 ft
<b>B</b> Front & Rear Wall SETBACK (min)	3 ft
<b>C</b> Ridge SETBACK (min)	1 ft
<b>D</b> Roof Slope (min)	4:12 (18.43°)
<b>E</b> Dormer Separation (min)	50% of dormer width

- ii. Standards
  - a). The face wall of a shed dormer may not project beyond the exterior wall of the BUILDING and may not interrupt the eave of the roof.
  - b). Cheek wall windows are permitted.
  - c). Shed dormers may be combined with a dormer window(s) to create a Nantucket dormer.
  - d). The cumulative width of a single, multiple, or attached combinations of dormers may equal up to fifty percent (50%) of the eave length of the roof below.

#### n. Cross Gable

- i. A cross GABLE is a sloped roof that projects perpendicularly from the MAIN ROOF of a BUILDING to significantly increase the HABITABLE space of a half-STORY.

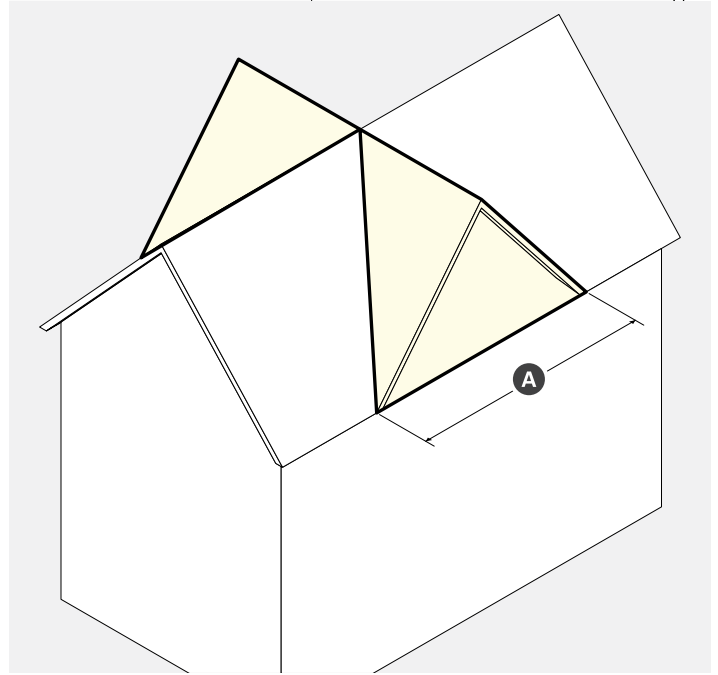

Dimensions	
<b>A</b> Width (max)	50% of the eave length of the MAIN ROOF

- ii. Standards
  - a). The ridge and eave of the cross GABLE must be structurally integrated into the ridge and eave of the MAIN ROOF.
  - b). Cross GABLES never have cheek walls.

## 13. Building Design Standards

- a. Contextual Front SETBACKS
  - i. Notwithstanding the front SETBACKS identified for each BUILDING TYPE, new construction must have a contextual front SETBACK as follows:
    - a). If the subject LOT is an INTERIOR LOT OR KEY LOT, the minimum and maximum front SETBACKS are equal to the actual distances that PRINCIPAL STRUCTURES BUILDING are set back from the FRONT LOT LINE ON the TWO ABUTTING LOTS of the same BLOCK FACE. See Figure 3.2.13.
    - b). If the subject LOT is a CORNER LOT, the minimum front SETBACK is equal to the actual distance that the PRINCIPAL STRUCTURE BUILDING is set back from the FRONT LOT LINE ON the ABUTTING LOT that is oriented toward the same THOROUGHFARE.
    - c). If the LOT on either side of the subject LOT is vacant, the minimum and maximum front SETBACK identified for each BUILDING TYPE governs.
  - ii. The contextual front SETBACK provision does not exempt any BUILDING from complying with the maximum front SETBACK required for each BUILDING TYPE.

## 14. Architectural Design Guidelines

- a. Residential Privacy
  - i. GROUND STORY DWELLING UNITS should be elevated above the grade of any adjacent sidewalk so that the window sills of the the DWELLING UNIT are at or above the eye-level of passing pedestrians. This elevation change maintains privacy for occupants while also encouraging open blinds or curtains to allow natural daylight into the unit.
  - ii. Dormer and sidewall window locations should break the direct line of sight between neighboring properties to every extent practicable. Translucent glass on the bottom half of windows or strategically placed landscape elements should be utilized if it is not practical to off-set windows in such a way as to minimize privacy impacts.
  - iii. Outdoor AMENITY SPACES that are elevated, such as roof DECKS, fully projecting balconies, and UPPER STORY rear porches should, provide sight-obscuring visual screening at the sides to increase privacy, security, and to limit views of ABUTTING properties from elevated vantage points.

Figure 3.2.13 Contextual Front Setback

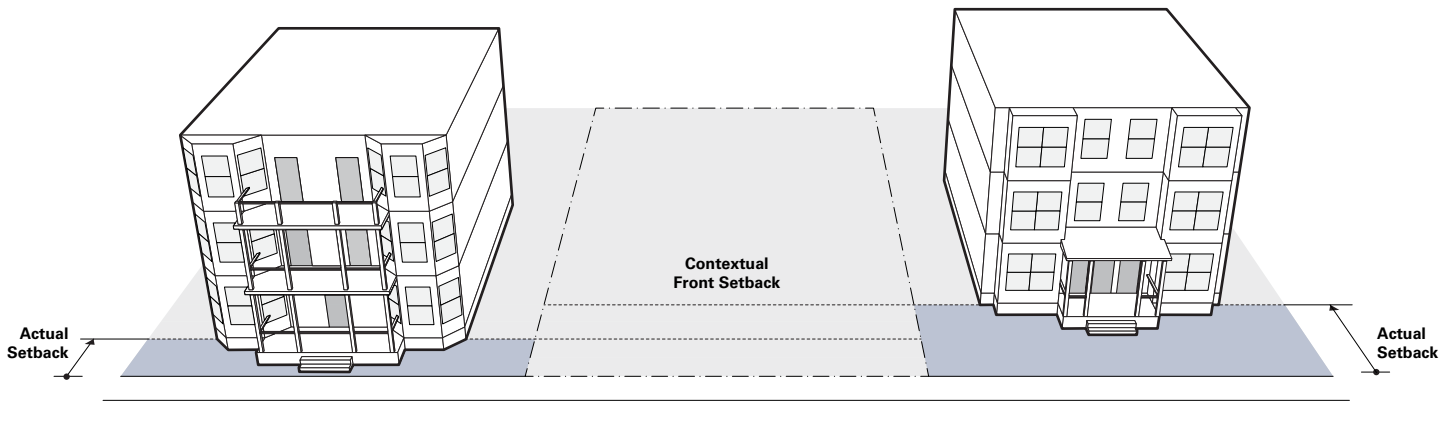

### 3. RESIDENTIAL DISTRICTS

Urban Residence (UR)

#### 15. Use Provisions

- a. General
  - i. The USE of real property is subject to the provisions of Article 9: USE Provisions of this Ordinance. Where the provisions of this section conflict with those of Article 9, the provisions of Article 9 apply.
  - ii. USE categories are permitted as specified on Table 3.2.15.
  - iii. USE categories not identified on Table 3.2.15 are prohibited.
  - iv. All USES must comply with any USE-specific standards applicable for each USE in §9.2 USE Definitions & Limitations.
  - v. USES permitted by Special Permit require additional DEVELOPMENT review in accordance with §15.2.1 Special Permits.
- b. Adaptive Re-Use of Specific Buildings
  - i. The USE of any PRINCIPAL STRUCTURE BUILDING constructed before the effective date of this Ordinance for a USE that is considered nonconforming in the Urban Residential district, as established by permit records or other historical documents accepted by the BUILDING OFFICIAL, or any BUILDING USED for municipal operations by the City of Somerville may be changed to any USE within the following PRINCIPAL USE categories in accordance with Table 3.2 (c):
    - a). ARTISINAL PRODUCTION;
    - b). Arts Sales & Services;
    - c). Design SERVICES;
    - d). Shared Workspace & Arts Education;
    - e). CONSUMER GOODS; or
    - f). Fresh Food Market or Grocery.

**Table 3.2.15 Permitted Uses**

Use Category Specific Use	UR
<b>Arts &amp; Creative Enterprise</b>	
Artisinal Production	SP
Arts Sales & Service	SP
Design Services	SP
Shared Workspace & Arts Education	SP
<b>Auto-Oriented</b>	
Motor Vehicle Parking (as noted below)	--
Off-Site Accessory Parking	SP
<b>Civic &amp; Institutional</b>	
Minor Utility Facility	SP
Public Service	P
Religious & Educational Uses Protected by M.G.L. 40A. Sec. 3	P
<b>Commercial Services</b>	
Day Care Service (as noted below)	--
Child Day Care Center	P
Vehicle Parking (except as follows)	N
Bike Share Parking	P
Car Share Parking (3 or fewer spaces)	P
Car Share Parking (4 or more spaces)	SP
<b>Lodging</b>	
Bed & Breakfast	SP
<b>Residential</b>	
Household Living	P
Group Living (except as follows)	SP
Community or Group Residence	P
Dormitory, Fraternity, or Sorority	SP
Homeless Shelter	N
Nursing Home/Assisted Living Facility	SP
Rooming House	SP

P - Permitted SP - Special Permit Required N - Not Permitted

**Table 3.2.15 Permitted Uses (continued)**

Use Category Specific Use	NR
<b>Retail Sales</b>	
<b>Consumer Goods (except as follows)</b>	<b>P</b>
Alcohol Sales	<b>N</b>
Firearms Sales	<b>N</b>
Pet Store	<b>N</b>
<b>Fresh Food Market or Grocery Store</b>	<b>P</b>
<b>Urban Agriculture</b>	
<b>Farming (as noted below)</b>	--
Commercial Farming	<b>N</b>
Community Farming	<b>P</b>
<b>Community Gardening</b>	<b>P</b>
<b>Accessory Uses</b>	
<b>Home Occupations (as noted below)</b>	--
Creative Studio	<b>P</b>
Home-Based Business	<b>P</b>
Home Office	<b>P</b>
<b>Urban Agriculture (as noted below)</b>	--
Apiculture	<b>P</b>
Aviculture	<b>P</b>
Commercial Farming	<b>P</b>
Residential Gardening	<b>P</b>
<b>Vehicle Parking, Accessory (except as follows)</b>	<b>P</b>
Home Business Vehicle Parking	<b>SP</b>

P - Permitted    SP - Special Permit Required    N - Not Permitted

## 16. Development Standards

- a. General
  - i. DEVELOPMENT is subject to the provisions of Article 10: DEVELOPMENT Standards of this Ordinance. Where the provisions of this section conflict with those of Article 10, the provisions of Article 10 apply.
- b. SIGNS
  - i. A SIGN, individual numerals or letters, or a nonelectrical nameplate identifying the property address is required for all real property as follows:
    - a). Each GROUND STORY non-residential USE must identify the STREET address either on the PRINCIPAL ENTRANCE door or above or beside the PRINCIPAL ENTRANCE of the USE.
    - b). All residential BUILDING TYPES must identify the STREET address either on the PRINCIPAL ENTRANCE door, above or beside the PRINCIPAL ENTRANCE, or on a mailbox.
  - ii. Address SIGNS must be made easily visible through the USE of colors or materials that contrast with the background material they are attached to and must be conspicuously located to provide visibility from the THOROUGHFARE that the BUILDING faces.
  - iii. Address SIGNS must be twelve (12) inches in height or less and may include the name of the occupant.

# 3. RESIDENTIAL DISTRICTS

Urban Residence (UR)

## 17. Parking & Mobility

- a. General
  - i. DEVELOPMENT is subject to the provisions of Article 11: Parking & Mobility of this Ordinance. Where the provisions of this section conflict with those of Article 11, the provisions of Article 11 apply.
  - ii. Vehicular parking must be provided as specified on Table 3.2.17, except as follows:
    - a). Non-residential USES with five thousand (5,000) square feet or less of GROSS LEASABLE FLOOR AREA are exempt from any minimum requirements of Table 3.2.17.
  - iii. There are no parking requirements for ACCESSORY USES.
  - iv. Parking may be shared between USES on the same LOT and buildings on the same BLOCK in accordance with §11.3 SHARED PARKING.
  - v. DEVELOPMENT outside of a TRANSIT AREA may count one (1) on STREET parking space for every twenty (20) feet of LOT WIDTH toward any minimum parking requirement if residential permit parking is permitted along the same side of the STREET as the LOT that the spaces will serve.
- b. Type
  - i. MOTOR VEHICLE PARKING may be provided as SURFACE PARKING spaces, above ground STRUCTURED PARKING, underground STRUCTURED PARKING, and on STREET parking spaces.
- c. Driveways
  - i. New driveways require a permit from the City Engineer.
  - ii. Driveways must be compliant with all City Ordinances and constructed in accordance with all standards established by relevant City Departments.
  - iii. Driveways are not permitted in the FRONTAGE AREA between a BUILDING and the FRONT LOT LINE.
  - iv. Driveways may be no wider than twelve (12) feet in the FRONTAGE AREA of a LOT.
  - v. Driveways may provide ACCESS in whole or in part on or across an ABUTTING LOT(s), provided that an ACCESS EASEMENT exists between all PROPERTY OWNERS.
  - vi. New driveways should accommodate at least two (2) motor vehicles for every one (1) ON-STREET PARKING SPACE that will be removed as a result of the new driveway.
  - vii. RIBBON DRIVEWAYS and permeable driveways are highly encouraged. See Figure 3.2 (b) for examples.
- d. Parking Design
  - i. The design of all parking is subject to §11.1 Bicycle Parking and §11.2 MOTOR VEHICLE PARKING of this Ordinance.
- e. Parking Location
  - i. Required vehicular parking, excluding any required handicapped parking, may be provided on a

**Table 3.2.17 Vehicular Parking**

Use Category Specific Use	BICYCLE		MOTOR VEHICLE	
	Short-Term (min)	Long-Term (min)	Within a TRANSIT AREA <sup>1</sup> (max)	Outside of a TRANSIT AREA <sup>1</sup> (min)
<b>Arts &amp; Creative Enterprise Uses</b>				
All Permitted Uses	1.0 / 10,000 sf	1.0 / 3,000 sf	none	1.0 / 1,000 sf
<b>Civic &amp; Institutional</b>				
Religious & Educational Uses Protected by M.G.L. 40A. Sec. 3	none	none	none	none
<b>Lodging Uses</b>				
Bed & Breakfast	none	2.0	none	1.0 / 4 rooms
<b>Residential Uses</b>				
All Permitted Uses	none	none	none	1.0 / DU
<b>Retail Sales Uses</b>				
All Permitted Uses	1.0 / 2,500 sf	1.0 / 10,000 sf	none	1.0 / 1,500 sf

sf - Gross Leasable Square Footage

DU - Dwelling Unit RU - Rooming Unit

<sup>1</sup> See the Transit Area Map



contiguous LOT under the same ownership as the LOT that the parking will serve as follows:

- a). Pedestrian ACCESS to off-SITE vehicular parking must be via a paved sidewalk or walkway.
- b). A lease, recorded covenant, or other comparable legal instrument guaranteeing long term USE of the SITE must be provided to the review board or BUILDING OFFICIAL and executed and filed with the Registry of Deeds.
- ii. For real property located in more than one municipality, MOTOR VEHICLE PARKING need not be located within the City of Somerville.
- f. Unbundled Parking
  - i. MOTOR VEHICLE PARKING spaces must be rented or leased as an option rather than a requirement of the rental, lease, or purchase of a DWELLING UNIT or non-residential floor space.
  - ii. Bicycle parking must be provided at no cost or fee to customers, visitors, employees, tenants, and residents.
- g. Parking Relief
  - i. Relief from the parking standards of Table 3.2.17 requires a Special Permit.
    - a). In addition to the review criteria for all Special Permits specified in §15.2.1.e. Review Criteria, the review board shall make findings considering the following in its discretion to approve or deny a special permit authorizing relief from the parking standards of Table 3.2.17:
      - i). The supply and demand of on-STREET

parking in the neighborhood, as determined through a parking study.

- ii). MOBILITY MANAGEMENT programs and services provided by the APPLICANT to reduce the demand for parking.
- iii). That parking provided in excess of any maximum permitted does not result in the increase in impervious LOT AREA.

#### 18. Public Realm

- a. Sidewalk CURB CUTS
  - i. A CURB CUT requires a permit from the City Engineer and must be compliant with all City Ordinances.
  - ii. Unless otherwise specified, the City Engineer may not permit more than one (1) CURB CUT per FRONT LOT LINE of a LOT.
  - iii. CURB CUTS are prohibited along all THOROUGHFARES designated as a PEDESTRIAN STREET.
  - iv. CURB CUTS must be located to minimize conflicts with pedestrians and bicyclists and must have a clear distance from fire hydrants, STREET TREES, utility poles, and other furnishings as deemed necessary by the City Engineer.
    - a). CURB CUTS for commercial or high-volume driveways should be at least one-hundred (100) feet from an UNSIGNALIZED or SIGNALIZED intersection.
    - b). CURB CUTS for residential driveways should be at least twenty (20) feet from an UNSIGNALIZED intersection and at least forty (40) feet from a

Figure 3.2.17 Example Driveways



### 3. RESIDENTIAL DISTRICTS

Urban Residence (UR)

SIGNALIZED intersection.

- v. The interior width of a CURB CUT (between curb stones) may be no wider than the driveway, vehicular entrance, or loading facility it serves.
- vi. A DRIVEWAY APRON may be installed only within the furnishing zone of a sidewalk and must be constructed in accordance with all standards established by relevant City Departments.
- vii. The grade, cross slope, and clear width of the walkway of a sidewalk must be maintained between the DRIVEWAY APRON and the ABUTTING driveway. The appearance of the walkway (ie. scoring pattern or paving material) must indicate that, although a vehicle may cross, the area traversed by a vehicle remains part of the sidewalk.

**Figure 3.2.19 Sidewalk Curb Cuts**

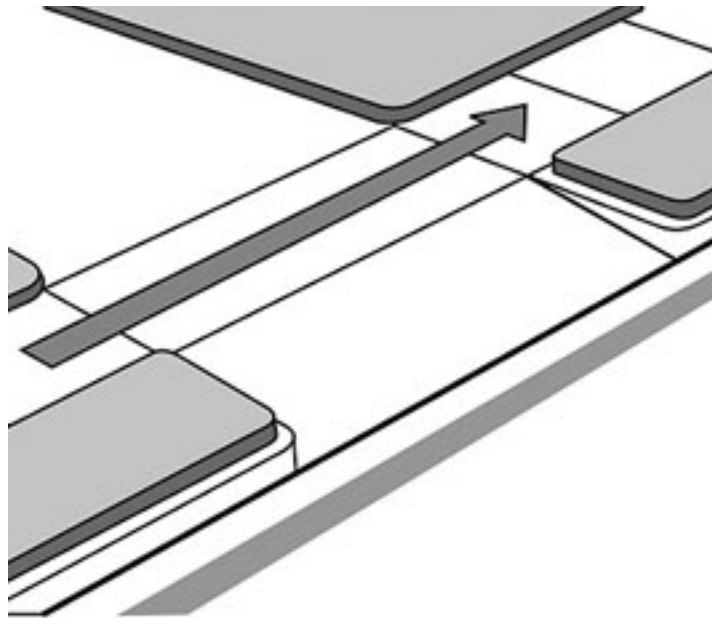

## 4 MID-RISE DISTRICTS

<b>4.1 MID-RISE 3 (MR3)</b> .....	<b>111</b>	<b>4.4 MID-RISE 6 (MR6)</b> .....	<b>195</b>
Description	111	Character Description	195
Intent	112	Intent	196
Purpose	112	Purpose	196
Applicability	112	Applicability	196
Development Review	112	Development Review	196
Building Types	112	Building Types	196
Building Components	125	Building Components	213
Facade Design	130	Facade Design	218
Architectural Design Guidelines	130	Architectural Design Guidelines	218
Use Provisions	132	Use Provisions	220
Development Standards	134	Development Standards	222
Parking & Mobility	135	Parking & Mobility	223
Public Realm	135	Public Realm	223
<b>4.2 MID-RISE 4 (MR4)</b> .....	<b>139</b>		
Character Description	139		
Intent	140		
Purpose	140		
Applicability	140		
Development Review	140		
Building Types	140		
Building Components	153		
Facade Design	158		
Architectural Design Guidelines	158		
Use Provisions	160		
Development Standards	162		
Parking & Mobility	163		
Public Realm	163		
<b>4.3 MID-RISE 5 (MR5)</b> .....	<b>167</b>		
Description	167		
Intent	168		
Purpose	168		
Applicability	168		
Development Review	168		
Building Types	168		
Building Components	181		
Facade Design	186		
Architectural Design Guidelines	186		
Use Provisions	188		
Development Standards	190		
Parking & Mobility	191		
PUBLIC REALM	191		



### 4.1 MID-RISE 3 (MR3)

#### 1. Description

The Mid-Rise 3 district is characterized by a variety of moderate FLOOR PLATE buildings up to three (3) stories in height. Buildings are set close to the sidewalk to create a defined STREET wall that supports pedestrian activity and a sense of place. The district is primarily commercial, with GROUND STORY USES that typically address the needs of residents and employees in the immediate neighborhood.



## 4. MID-RISE DISTRICTS

### Mid-Rise 3 (MR3)

#### 2. Intent

- a. To implement the objectives of the COMPREHENSIVE PLAN of the City of Somerville.
- b. To create, maintain, and enhance areas appropriate for smaller scale, multi-USE and mixed-USE buildings and neighborhood serving commercial USES.

#### 3. Purpose

- a. To permit the DEVELOPMENT of multi-unit and mixed-USE buildings that do not exceed three (3) stories in height.
- b. To provide quality commercial spaces and permit small-scale, neighborhood serving commercial USES.
- c. To create DWELLING UNIT types, sizes, and BEDROOM counts ideal for larger households in apartment buildings.
- d. To create DWELLING UNIT types, sizes, and BEDROOM counts ideal for smaller households in general buildings.
- e. To permit increased residential density for buildings that meet the definition of a NET ZERO BUILDING or 100% AFFORDABLE HOUSING.

#### 4. Applicability

- a. The section is applicable to all real property within the Mid-Rise 3 district as shown on the maps of the Official Zoning Atlas of the City of Somerville.

#### 5. Development Review

- a. DEVELOPMENT review is subject to the provisions of Article 15: Administration of this Ordinance.
- b. All DEVELOPMENT, excluding NORMAL MAINTENANCE, requires the submittal of a development review application to the BUILDING OFFICIAL and the issuance of a Certificate of Zoning Compliance prior to the issuance of a BUILDING Permit or Certificate of Occupancy.
- c. Proposed DEVELOPMENT may or may not necessitate the need for SUBDIVISION Plan Approval, Subdivision Plan Approval, Site Plan Approval, a Special Permit, or a Hardship Variance based on the nature of the proposal. In such cases, additional DEVELOPMENT review is required in accordance with Article 15: Administration.
  - i. The Planning Board is the decision making authority for all DEVELOPMENT that requires Site Plan Approval or a Special Permit.
  - ii. The Zoning Board of Appeals is the Review Board for all HARDSHIP Variances.
- d. Upon verification that no additional DEVELOPMENT review is necessary, or completion of the required DEVELOPMENT review, The BUILDING OFFICIAL shall issue a Zoning Compliance Certificate to certify compliance with the provisions and procedures of this Ordinance.

#### 6. Building Types

- a. One (1) PRINCIPAL BUILDING TYPE is permitted on each LOT.
- b. The following BUILDING TYPES are permitted by Site Plan Approval in the Mid-Rise 3 district:
  - i. Apartment Building
  - ii. General Building
  - iii. Commercial Building
- c. Apartment Buildings are prohibited on any LOT fronting a PEDESTRIAN STREET.
- d. ACCESSORY structures are regulated according to Article 10: DEVELOPMENT Standards of this Ordinance.



## 4.1.7 Apartment Building

A small to moderate FLOOR PLATE, multi-STORY, PRINCIPAL BUILDING TYPE purpose built for OCCUPATION by residential USES on all stories.

The following images are examples of the apartment BUILDING TYPE and are intended only for illustrative purposes.



# 4. MID-RISE DISTRICTS

Mid-Rise 3 (MR3)

## 4.1.7. Apartment Building (continued)

a. LOT Standards

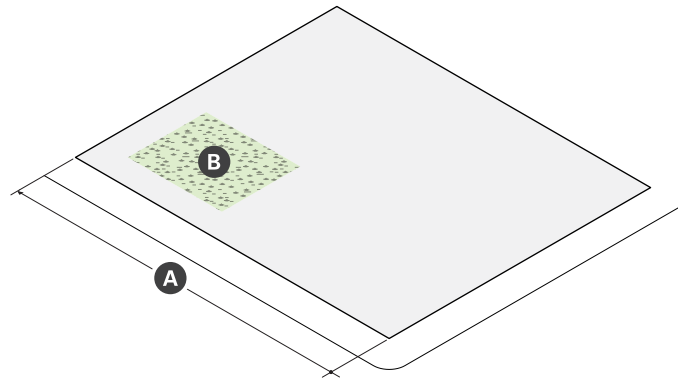

Lot Dimensions	
<b>A</b> LOT WIDTH (min)	30 ft

Lot Development	
LOT Coverage (max)	90%
GREEN SCORE	--
Minimum	0.25
Ideal	0.30
<b>B</b> OPEN SPACE (min)	15%

b. BUILDING Placement

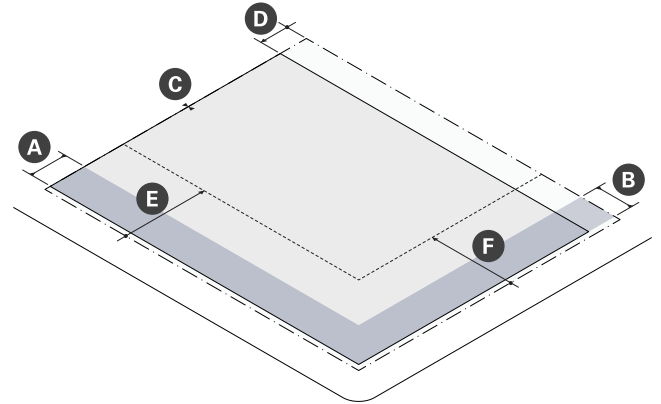

Building Setbacks		
<b>A</b> Primary Front SETBACK (min/max)	2 ft	12 ft
<b>B</b> Secondary Front SETBACK (min/max)	2 ft	12 ft
<b>C</b> Side SETBACK (min)	0 ft	
Side SETBACK ABUTTING NR or LHD (min)	10 ft	
<b>D</b> Rear SETBACK (min)	--	
ALLEY	0 ft	
No ALLEY	10 ft	
No ALLEY & ABUTTING NR or LHD	15 ft	

Parking Setbacks	
<b>E</b> Primary Front SETBACK (min)	--
SURFACE PARKING	30 ft
STRUCTURED PARKING	30 ft
<b>F</b> Secondary Front SETBACK (min)	--
SURFACE PARKING	10 ft
STRUCTURED PARKING	2 ft

## 4.1.7. Apartment Building (continued)

### c. Massing & Height

### d. Uses & Features

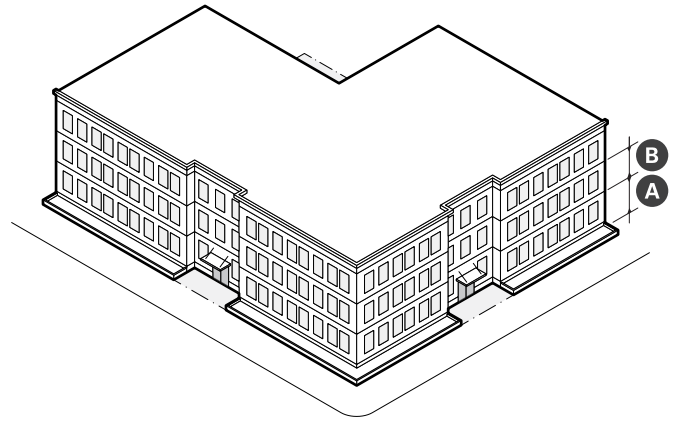
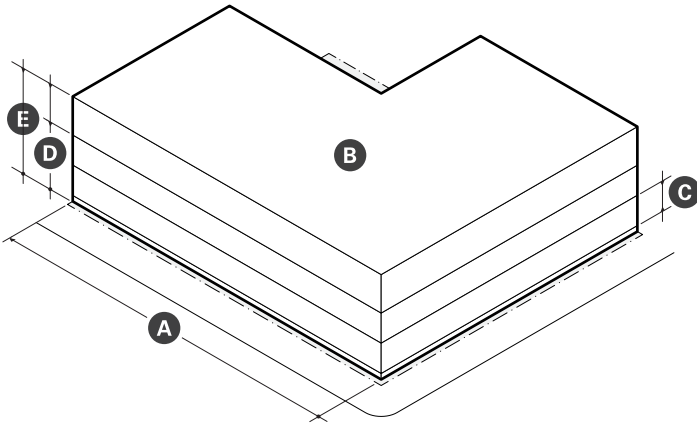

Main Massing	
<b>A</b> BUILDING WIDTH (max)	200 ft
FACADE Build Out (min)	--
Primary Front	80%
Secondary Front	65%
<b>B</b> FLOOR PLATE (max)	15,000 sf
GROUND STORY Elevation (min)	2 ft
<b>C</b> STORY Height (min)	10 ft
<b>D</b> Number of Stories (min/max)	2   3
<b>E</b> BUILDING Height, Feet (max)	40 ft
Roof Type	Flat

Facade Composition	
<b>A</b> GROUND STORY FENESTRATION (min/max)	20%   50%
<b>B</b> UPPER STORY FENESTRATION (min/max)	20%   50%
BLANK WALL (max)	20 ft

Use & Occupancy	
GROSS FLOOR AREA per DU	--
LOT AREA < 5,000 sf	1,500
LOT AREA >= 5,000 sf	1,125
NET ZERO BUILDING	850
100% AFFORDABLE HOUSING	850
Outdoor AMENITY SPACE (min)	1/DU

## 4. MID-RISE DISTRICTS

Mid-Rise 3 (MR3)

### 4.1.7. Apartment Building (continued)

- e. DEVELOPMENT Benefits
  - i. DEVELOPMENT of an apartment building is subject to the provisions of Article 12: DEVELOPMENT Benefits of this Ordinance. Where the provisions of this section conflict with those of Article 12, the provisions of Article 12 apply.
  - ii. DEVELOPMENT of a general building must provide AFFORDABLE DWELLING UNITS as specified on Table 4.1.7.
- f. Design Guidelines
  - i. GROUND STORY DWELLING UNITS should be elevated above the grade of any adjacent sidewalk so that the window sills of the the DWELLING UNIT are at or above the eye-level of passing pedestrians. This elevation change maintains privacy for occupants while also encouraging open blinds or curtains to allow natural daylight and ventilation into the unit.
  - ii. FENESTRATION patterns and window configurations that break the direct line of sight between neighboring properties should be utilized to every extent possible. Translucent glass on the bottom half of windows or strategically placed landscape elements should be utilized if it is not practical to off-set windows in such a way as to minimize privacy impacts.
  - iii. Outdoor AMENITY SPACES that are elevated, such as roof DECKS, fully projecting balconies, and UPPER STORY rear porches should, provide sight-obscuring visual screening at the sides to increase privacy, security, and to limit views of ABUTTING properties from elevated vantage points.

**Table 4.1.7 Required ADUs**

Total DWELLING UNITS	Required ADUs
0 to 5 units	None
6 units	1 unit OR fractional buyout for 0.4 units
7 units	1 unit OR fractional buyout for 0.6 units
8 to 17 units	17.5% of units
18 or more units	20% of units



## 4.1.8 General Building

A moderate FLOOR PLATE, multi-STORY PRINCIPAL BUILDING TYPE with GROUND STORY commercial space and no limitations on the occupancy of upper stories for permitted USES. The upper stories of a general building are typically residential, but a wide variety exists. As the number of stories increases, it becomes more likely for the upper stories of a general building to host commercial uses as well as residential.

The following images are examples of the general BUILDING TYPE and are intended only for illustrative purposes.



# 4. MID-RISE DISTRICTS

Mid-Rise 3 (MR3)

## 4.1.8. General Building (continued)

a. Lot Standards

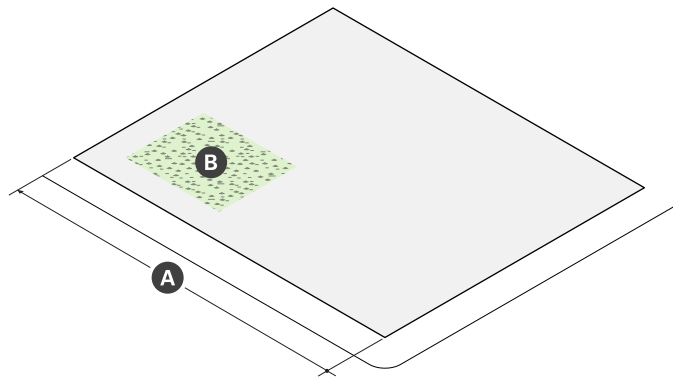

Lot Dimensions	
<b>A</b> LOT WIDTH (min)	30 ft

Lot Development	
LOT Coverage (max)	90%
GREEN SCORE	--
Minimum	0.25
Ideal	0.30
<b>B</b> OPEN SPACE (min)	15%

b. BUILDING Placement

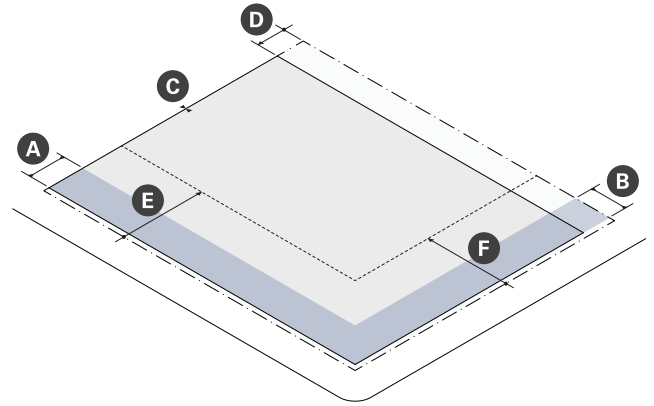

Building Setbacks		
<b>A</b> Primary Front SETBACK (min/max)	2 ft	12 ft
<b>B</b> Secondary Front SETBACK (min/max)	2 ft	12 ft
<b>C</b> Side SETBACK (min)	0 ft	
Side SETBACK ABUTTING NR or LHD (min)	10 ft	
<b>D</b> Rear SETBACK (min)	--	
ALLEY	0 ft	
No ALLEY	10 ft	
No ALLEY & ABUTTING NR or LHD	15 ft	

Parking Setbacks	
<b>E</b> Primary Front SETBACK (min)	--
SURFACE PARKING	30 ft
STRUCTURED PARKING	30 ft
<b>F</b> Secondary Front SETBACK (min)	--
SURFACE PARKING	10 ft
STRUCTURED PARKING	2 ft



### 4.1.8. General Building (continued)

c. Massing & Height

d. Uses & Features

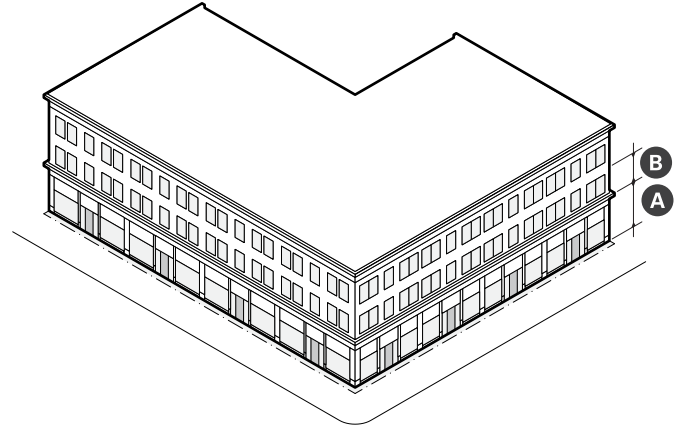
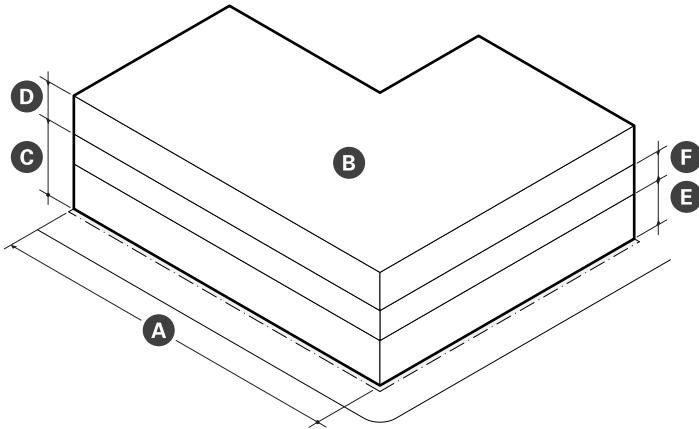

Main Massing	
<b>A</b> BUILDING WIDTH (max)	200 ft
FACADE Build Out, Primary Front (min)	--
Primary Front	80%
Secondary Front	65%
<b>B</b> FLOOR PLATE (max)	15,000 sf
<b>C</b> GROUND STORY Height (min)	14 ft
<b>D</b> UPPER STORY Height (min)	10 ft
<b>E</b> Number of Stories (min/max)	2   3
<b>F</b> BUILDING Height, Feet (max)	45 ft
Roof Type	Flat

Facade Composition	
<b>A</b> GROUND STORY FENESTRATION (min)	70%
<b>B</b> UPPER STORY FENESTRATION (min/max)	20%   50%
BLANK WALL (max)	20 ft

Use & Occupancy	
GROUND STORY Entrance Spacing (max)	30 ft
Commercial Space Depth (min)	30 ft
GROSS FLOOR AREA per DU	--
LOT AREA < 5,000 sf	1,500
LOT AREA >= 5,000 sf	1,125
NET ZERO BUILDING	850
100% AFFORDABLE HOUSING	850
Outdoor AMENITY SPACE (min)	1/DU

## 4. MID-RISE DISTRICTS

Mid-Rise 3 (MR3)

### 4.1.8. General Building (continued)

- e. DEVELOPMENT Benefits
  - i. DEVELOPMENT is subject to the provisions of Article 12: DEVELOPMENT Benefits of this Ordinance. Where the provisions of this section conflict with those of Article 12, the provisions of Article 12 apply.
  - ii. DEVELOPMENT of a general building must provide AFFORDABLE DWELLING UNITS as specified on Table 4.1.8 (a).
  - iii. DEVELOPMENT of a general building must provide linkage payments as specified on Table 4.1.8. (b).
- f. Design Guidelines
  - i. FENESTRATION patterns and window configurations should break the direct line of sight between neighboring properties to every extent practicable. Translucent glass on the bottom half of windows or strategically placed landscape elements should be utilized if it is not practical to off-set windows in such a way as to minimize privacy impacts.
  - ii. Outdoor AMENITY SPACES that are elevated, such as roof DECKS, fully projecting balconies, and UPPER STORY rear porches should, provide sight-obscuring visual screening at the sides to increase privacy, security, and to limit views of ABUTTING properties from elevated vantage points.

**Table 4.1.8. (a) Required ADUs**

Total DWELLING UNITS	Required ADUs
0 to 5 units	None
6 units	1 unit OR fractional buyout for 0.4 units
7 units	1 unit OR fractional buyout for 0.6 units
8 to 17 units	17.5% of units
18 or more units	20% of units

**Table 4.1.8 (b) Linkage**

Commercial GROSS FLOOR AREA	Affordable Housing Linkage	Employment Linkage
30,000 sf or less	None	None
Over 30,000 sf	\$10/sf	\$2.46/sf

## 4.1.9 Commercial Building

A moderate FLOOR PLATE, multi-STORY, PRINCIPAL BUILDING TYPE purpose built for occupation by commercial USES on all stories. GROUND STORY commercial space is primarily occupied by commercial service, food & beverage service, or retail sales PRINCIPAL USES. Floor space on upper stories may be occupied by retail USES that do not rely on the visibility of a storefront at sidewalk level.

The following images are examples of the commercial BUILDING TYPE and are intended only for illustrative purposes.



# 4. MID-RISE DISTRICTS

Mid-Rise 3 (MR3)

## 4.1.9 Commercial Building (continued)

a. LOT Standards

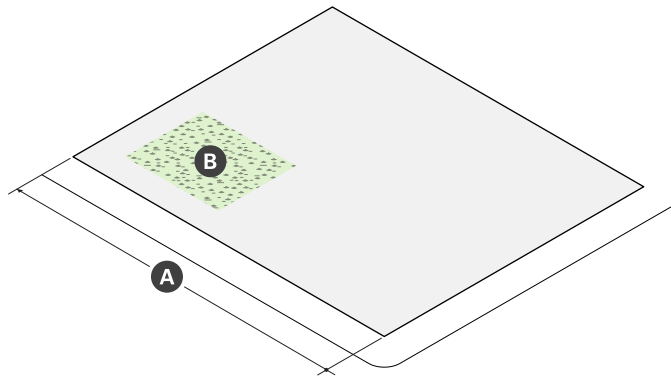

Lot Dimensions	
<b>A</b> LOT WIDTH (min)	30 ft

Lot Development	
LOT Coverage (max)	90%
GREEN SCORE	--
Minimum	0.25
Ideal	0.30
<b>B</b> OPEN SPACE (min)	15%

b. BUILDING Placement

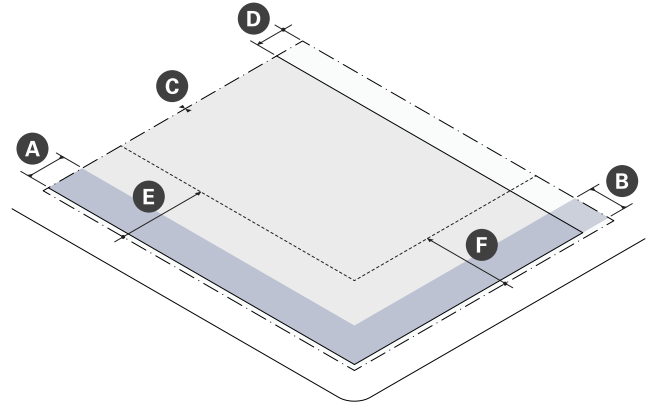

Building Setbacks		
<b>A</b> Primary Front SETBACK (min/max)	2 ft	12 ft
<b>B</b> Secondary Front SETBACK (min/max)	2 ft	12 ft
<b>C</b> Side SETBACK (min)	0 ft	
Side SETBACK ABUTTING NR or LHD (min)	10 ft	
<b>D</b> Rear SETBACK (min)	--	
ALLEY	0 ft	
No ALLEY	10 ft	
No ALLEY & ABUTTING NR or LHD	15 ft	

Parking Setbacks	
<b>E</b> Primary Front SETBACK (min)	--
SURFACE PARKING	30 ft
STRUCTURED PARKING	30 ft
<b>F</b> Secondary Front SETBACK (min)	--
SURFACE PARKING	10 ft
STRUCTURED PARKING	2 ft

## 4.1.9 Commercial Building (continued)

### c. Massing & Height

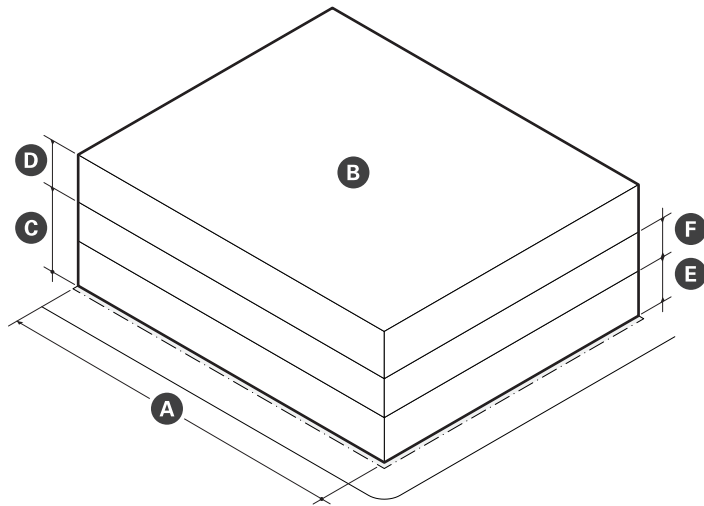

Main Massing	
<b>A</b> BUILDING WIDTH (max)	200 ft
FACADE Build Out, (min)	--
Primary Front	80%
Secondary Front	65%
<b>B</b> FLOOR PLATE (max)	15,000 sf
<b>C</b> GROUND STORY Height (min)	14 ft
<b>D</b> UPPER STORY Height (min)	10 ft
<b>E</b> NUMBER OF STORIES (min)	2   3
<b>F</b> BUILDING Height, Feet (max)	50 ft
Roof Type	Flat

### d. Uses & Features

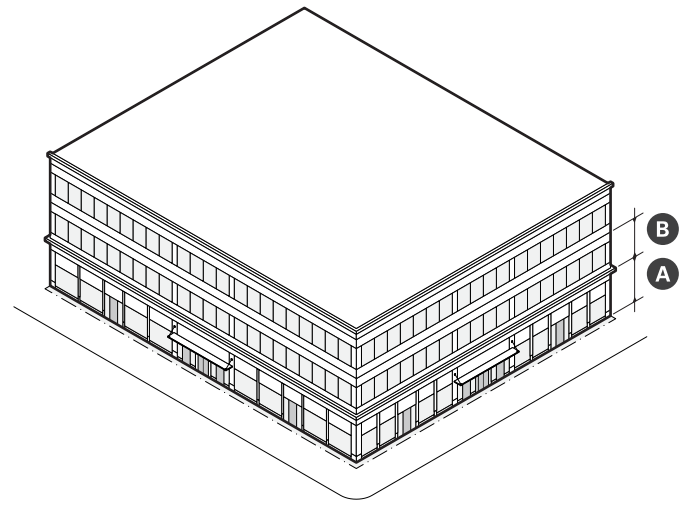

Facade Composition	
<b>A</b> GROUND STORY FENESTRATION (min)	70%
<b>B</b> UPPER STORY FENESTRATION (min/max)	20%   70%
BLANK WALL (max)	20 ft

Use & Occupancy	
GROUND STORY Entrance Spacing (max)	30 ft
Commercial Space Depth (min)	30 ft

## 4. MID-RISE DISTRICTS

Mid-Rise 3 (MR3)

### 4.1.9. Commercial Building (continued)

- e. DEVELOPMENT Benefits
  - i. DEVELOPMENT is subject to the provisions of Article 12: DEVELOPMENT Benefits of this Ordinance. Where the provisions of this section conflict with those of Article 12, the provisions of Article 12 apply.
  - ii. DEVELOPMENT of a general building must provide linkage payments as specified on Table 4.1.9.

**Table 4.1.9 Linkage**

<b>Commercial GROSS FLOOR AREA</b>	<b>Affordable Housing Linkage</b>	<b>Employment Linkage</b>
30,000 sf or less	None	None
Over 30,000 sf	\$10/sf	\$2.46/sf



**10. Building Components**

- a. Building components are ACCESSORY elements attached to the MAIN MASSING of a PRINCIPAL BUILDING.
- b. Building components are permitted by Site Plan Approval as specified on Table 4.1.10.
  - i. At least one (1) storefront is required for each GROUND STORY commercial space.
- c. Building components not identified on Table 4.1.10 are prohibited.
- d. Unless otherwise specified, building components may attach to other building components to create assemblies of components.

**Table 4.1.10 Building Components**

	Apartment BUILDING	General BUILDING	Commercial BUILDING
Awning	N	P	P
Entry Canopy	P	P	P
Lobby Entrance	P	P	P
Storefront	N	P	P
Stoop	P	N	N
Bay Window	P	P	P
Balcony	P	P	N
Arcade	N	N	N

P - Permitted      N - Not Permitted

# 4. MID-RISE DISTRICTS

## Mid-Rise 3 (MR3)

### e. Awning

- i. An awning is a wall mounted frame covered with fabric or other material that provides shade and weather protection over a storefront or building entrance.

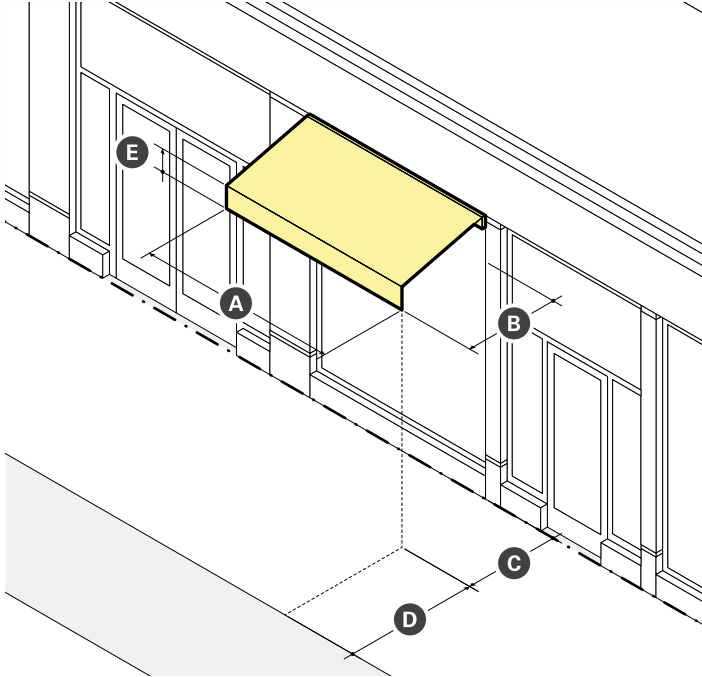

Dimensions	
<b>A</b> Width (min)	See ii Standards
<b>B</b> Projection (min)	3 ft
<b>C</b> CLEARANCE (min)	8 ft
Front SETBACK ENCROACHMENT (max)	100%
<b>D</b> SETBACK from Curb (min)	2 ft
<b>E</b> Valance Height (max)	12 in

- ii. Standards
  - a). Awnings must be securely attached to and supported by the building and must fit the windows or doors the awning is attached to.
  - b). An awning must be made of durable, weather-resistant material that is water repellent.
  - c). Internally illuminated or back-lit awnings are prohibited.
  - d). An awning that projects over the sidewalk of a public THOROUGHFARE requires compliance with all City Ordinances.

### f. Entry Canopy

- i. An entry canopy is a wall-mounted structure that provides shade and weather protection over a storefront or building entrance.

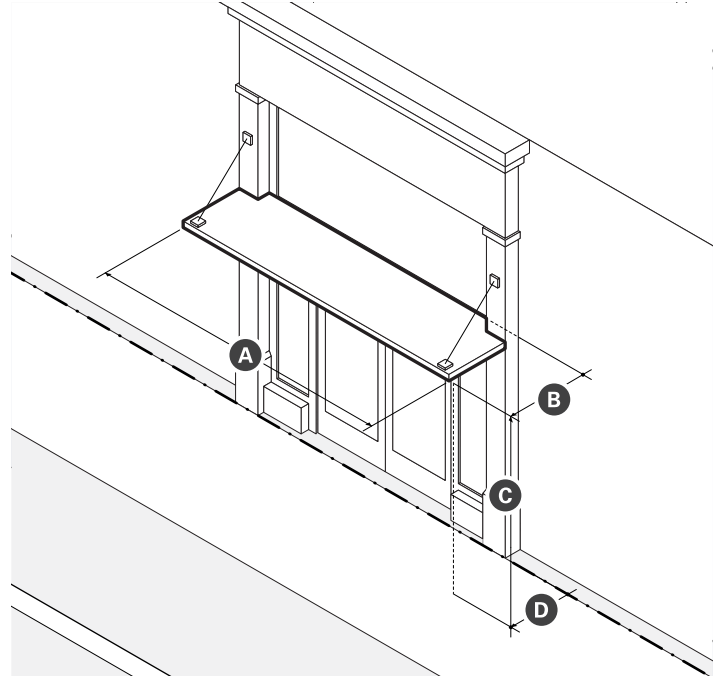

Dimensions	
<b>A</b> Width (min)	See ii Standards
<b>B</b> Projection (min)	3 ft
<b>C</b> CLEARANCE (min)	8 ft
<b>D</b> Front SETBACK ENCROACHMENT (max)	100%
SETBACK from Curb (min)	2 ft

- ii. Standards
  - a). Entry canopies must be visually supported by brackets, cables, or rods.
  - b). The width of an entry canopy must be equal to or greater than the width of the doorway surround or exterior casing it is mounted over.

**g. Lobby Entrance**

- i. A lobby entrance is a non-load bearing assembly of entry doors and windows providing access and light to the lobby of a building.

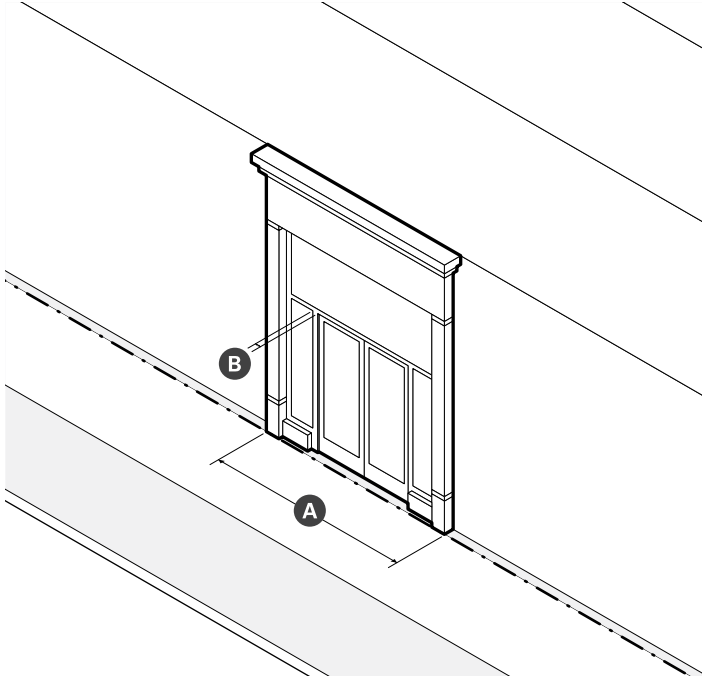

Dimensions		
<b>A</b> Width (min/max)	15 ft	30 ft
<b>B</b> Height (min)	80% of GROUND STORY Height	
Recessed Entrance Width (max)	15 ft	
Recessed Entrance Depth (max)	5 ft	

- ii. Standards
  - a). When a lobby entrance is set back from the FRONT LOT LINE, the FRONTAGE AREA must be paved.

**h. Storefront**

- i. A storefront is a non-load bearing assembly of commercial entry doors and windows providing ACCESS and light to a commercial space and a place to display goods, services, and SIGNS.

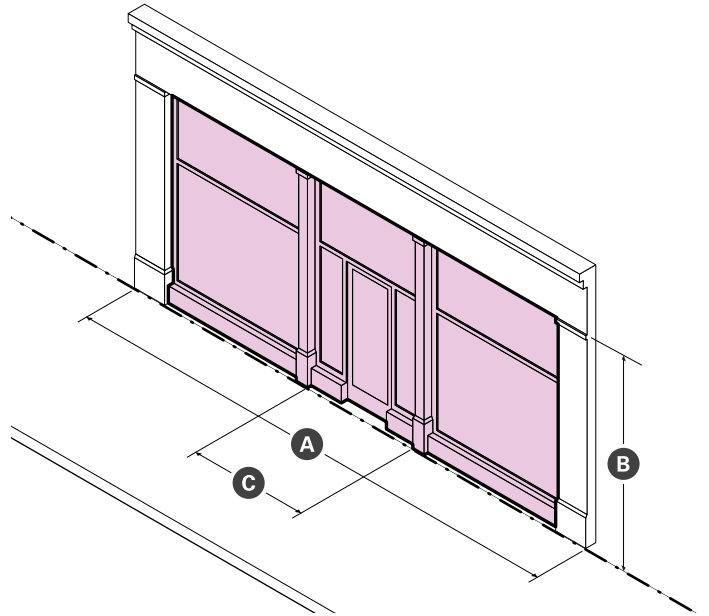

Dimensions		
<b>A</b> Width (min/max)	15 ft	30 ft
<b>B</b> Height (min)	80% of GROUND STORY Height	
Display Window Height (min)	8 ft	
Recessed Entrance Width (max)	15 ft	
Recessed Entrance Depth (max)	5 ft	

- ii. Standards
  - a). An unobstructed view of the interior space or a lighted and maintained merchandise display(s) must be provided for a depth of at least four (4) feet behind storefront display windows.
  - b). When storefronts are set back from the FRONT LOT LINE, the FRONTAGE AREA must be paved.
  - c). When present, awnings and canopies must be mounted between columns, PILASTERS, OR PIERS; above doorways and display windows; and below the SIGN BAND.
  - d). Exterior security grilles, gates, and roll-down security doors and windows are prohibited.

# 4. MID-RISE DISTRICTS

Mid-Rise 3 (MR3)

## i. Stoop

- i. A stoop is a set of stairs with a landing leading to the entrance of a building.

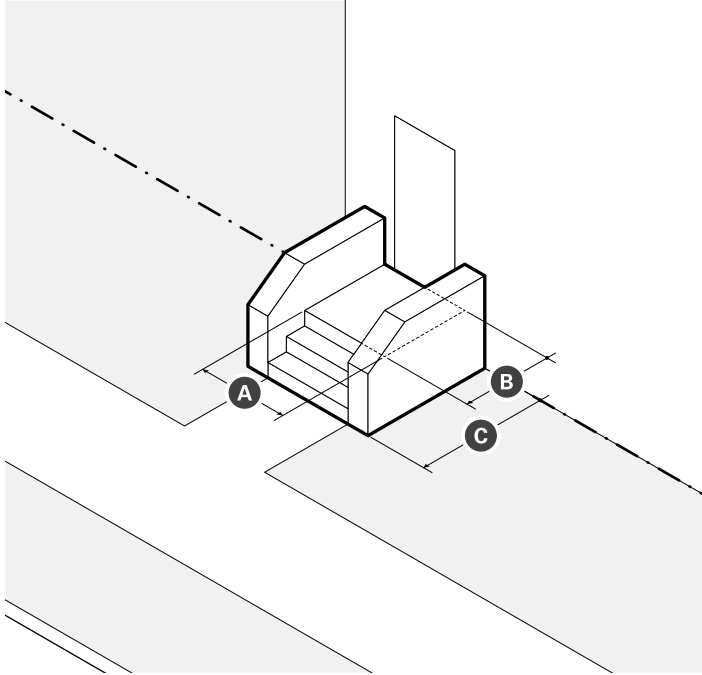

Dimensions	
<b>A</b> Landing Width (min)	4 ft
<b>B</b> Landing Depth (min)	4 ft
<b>C</b> Front SETBACK ENCROACHMENT (max)	100%

- ii. Standards
  - a). Paving, excluding driveways, must match the ABUTTING sidewalk unless paved with pervious, porous, or permeable materials.
  - b). Stairs may be recessed into the building FACADE when the building is set back four (4) feet or less.
  - c). Stairs are not permitted to ENCROACH onto any ABUTTING sidewalk.
  - d). Stairs may be built perpendicular or parallel to the building FACADE, but must lead directly to ground level or an ABUTTING sidewalk.

## j. Bay Window

- i. A bay window is an assembly of windows projecting from a building to provide additional HABITABLE space, increased light, multi-directional views, and ARTICULATION to an exterior wall.

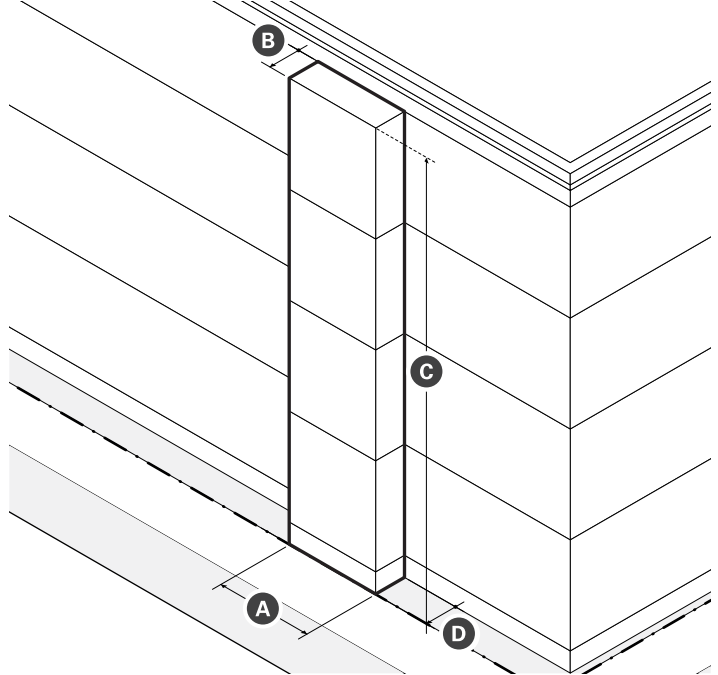

Dimensions	
<b>A</b> Width (max)	16 ft
<b>B</b> Projection (max)	3 ft
<b>C</b> Height (max)	Height of BUILDING in Stories
<b>D</b> Front SETBACK ENCROACHMENT (max)	3 ft
FENESTRATION (min)	60%

- ii. Standards
  - a). Bay windows, including box and bow windows, must include at least three (3) windows.
  - b). The cumulative width of multiple bays may equal up to fifty percent (50%) of the width of the exterior wall from which the bays project.
  - c). Bays projecting over the sidewalk of a public THOROUGHFARE must have at least two (2) stories of CLEARANCE and be compliant with all City Ordinances.

## k. Balcony

- i. A balcony is a platform with a railing that provides outdoor AMENITY SPACE.

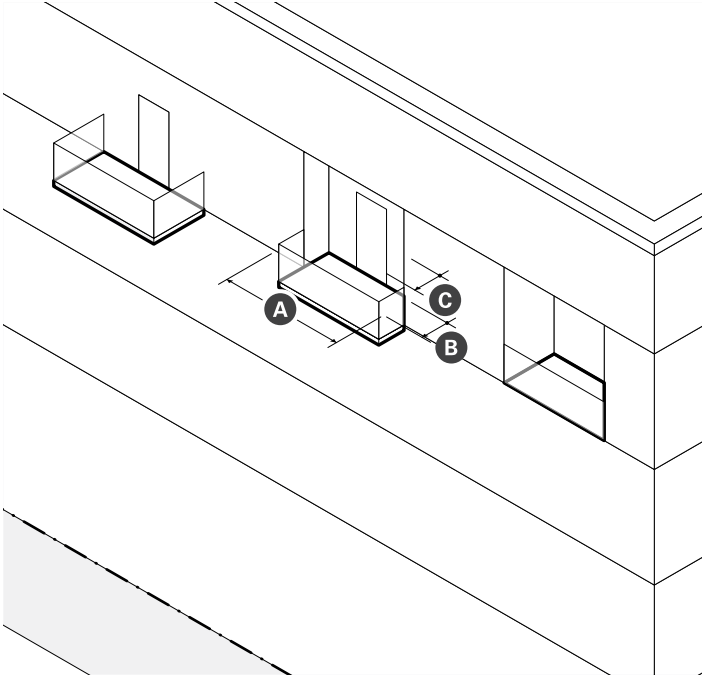

Dimensions	
<b>A</b> Width (min)	5 ft
<b>B</b> Depth (max)	5 ft
<b>D</b> Area (min)	50 ft
CLEARANCE (min)	10 ft
Permitted Front SETBACK ENCROACHMENT (max)	6 ft

- ii. Standards
  - a). Balconies may be recessed, projecting, a combination of the two, or terraced as part of the roof of a portico, porch, or bay.
  - b). A balcony that projects over the sidewalk of a public THOROUGHFARE requires compliance with all City Ordinances.
  - c). The guard rail of any balcony oriented toward a FRONT LOT LINE must permit visual supervision of the PUBLIC REALM through the posts and rails.
  - d). The guard rail of any balcony oriented toward a side OF REAR LOT LINE ABUTTING the NR district must include sight-obscuring visual screening so that it is at least fifty percent (50%) opaque.

## l. Arcade

- i. An arcade is a pedestrian walkway covered by the upper floors of a building. The GROUND STORY FACADE is SETBACK and upper floors are supported by a colonnade or supports.

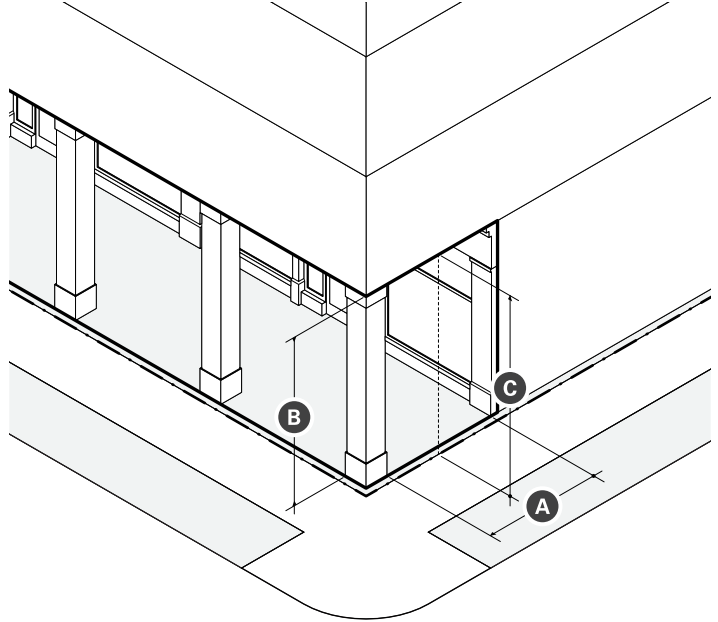

Dimensions		
<b>A</b> Depth (min/max)	10 ft	15 ft
<b>B</b> Height (max)	1 STORY	
<b>C</b> CLEARANCE (min/max)	14 ft	24 ft

- ii. Standards
  - a). Arcades must extend the entire width of a building and must have a consistent depth.
  - b). Support columns or PIERS may be spaced no farther apart than they are tall.
  - c). Arcades are considered part of the building for the purpose of measuring FACADE build out.
  - d). Arcades may be combined only with storefront and lobby entrance frontages.
  - e). The finished ceiling of an arcade interior may be arched or flat, but must have a greater CLEARANCE than the openings between columns OR PIERS.

## 4. MID-RISE DISTRICTS

### Mid-Rise 3 (MR3)

#### 11. Facade Design

- a. FACADES must provide solid material framing each storefront and lobby entrance as follows:
  - i. PILASTERS or columns supporting a horizontal lintel and CORNICE;
  - ii. a spandrel positioned between PILASTERS or columns that extend from upper stories of the building to the ground; or
  - iii. flat wall above and to either side of a void or punched opening.
- b. Storefronts and lobby entrances must be set within the resulting frame provided for each by the FACADE.
- c. Materials framing each storefront or lobby entrance may be integrated into the design of the FACADE or customized for individual storefronts and lobby entrances.
- d. Mechanical louvers necessary for venting purposes are not permitted in the required frame, but may be incorporated into any storefront or lobby entrance system.
- e. FACADES must differentiate the GROUND STORY of the building from the upper stories through horizontal ARTICULATION, a change in material, or a change in window size or pattern to create a distinct base to the building FACADE. The entire height of the GROUND STORY must be included in the FACADE base.
- f. For buildings with more than one FACADE, the design of the base must align horizontally at the corner.
- g. FACADES must provide surface relief from the average plane of the FACADE by at least four (4) inches, through

the USE of architectural elements such as bay windows, columns, CORNER BOARDS, CORNICES, door and window surrounds, moldings, PIERS, PILASTERS, recessed storefronts or lobby entrances, seat walls, sills, wall thickness, and recessed or projecting windows.

- h. The FACADE of any building greater than one hundred (100) feet in width must be designed as two (2) or more separate and distinct facades of differing architectural design so that the building appears to be multiple buildings. The facade designs must include a change in CORNICE, roof eave, or parapet design from one another.

#### 12. Architectural Design Guidelines

- a. FACADES should be visually divided into a series of ARCHITECTURAL BAYS that are derived, in general, from the building's structural bay spacing.
- b. PIERS, PILASTERS, or other features defining each ARCHITECTURAL BAY should either extend all the way to the ground or terminate at any horizontal ARTICULATION defining the base of the building.
- c. ARCHITECTURAL BAYS should align, in general, with individual or groups of storefronts and lobby entrances.
- d. PIERS, PILASTERS, or other features defining each ARCHITECTURAL BAY should always project forward and be uninterrupted by any horizontal articulation, excluding any horizontal ARTICULATION USED to differentiate the base of the building.
- e. Vents, exhausts, and other utility features on building FACADES should be architecturally integrated into

**Figure 4.1.11 (a) Storefront & Lobby Entrance Framing**

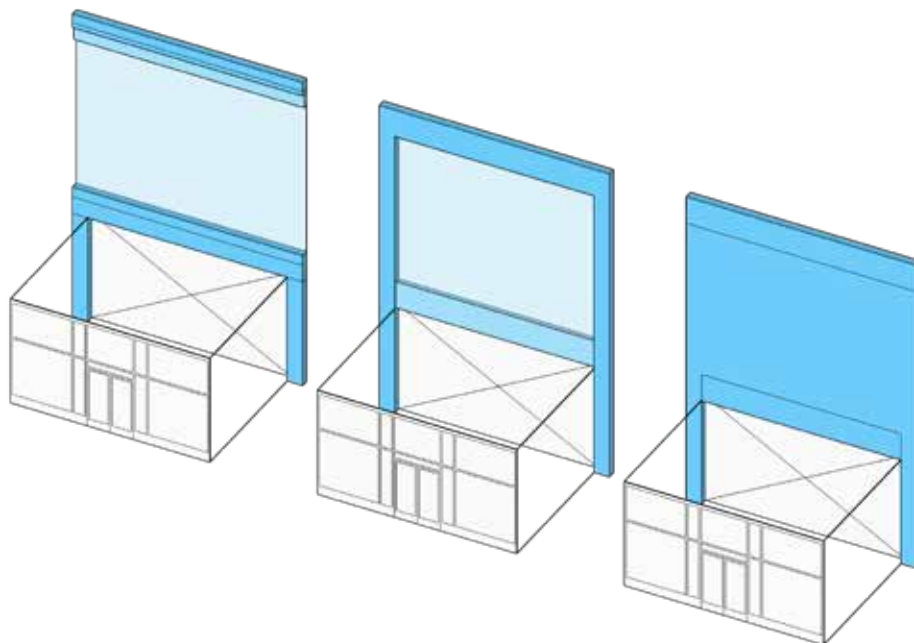



the design of the building and should be located to minimize adverse effects on pedestrian comfort along sidewalks and within OPEN SPACES.

- f. Buildings at TERMINATED VISTAS should be ARTICULATED with design features that function as focal points.
- g. FENESTRATION glazing should be inset from the plane of exterior wall surfaces.
- h. RIBBON WINDOWS should be avoided.
- i. Monotonous and repetitive storefront or lobby systems, awnings, canopies, SIGN types, colors, or designs should be avoided.
- j. Storefronts and lobby entrances should include awnings or canopies to provide weather protection for pedestrians and reduce glare for storefront display areas. Awnings should be open-ended and operable.
- k. Lobby entrances for UPPER STORY USES should be optimally located, well defined, clearly visible, and separate from the entrance for other GROUND STORY USES.
- l. Lobbies should be limited in both width and total area to preserve floor space and frontage for other GROUND STORY USES. Buildings should USE any combination of FACADE ARTICULATION, a double-height ceiling, a distinctive doorway, a change in wall material, a change in paving material within the FRONTAGE AREA, or some other architectural element(s) to make lobbies visual and materially distinctive.
- m. The selection of materials, FENESTRATION, and ornamentation should result in a consistent and harmonious composition that appears as a unified whole rather than a collection of unrelated parts, no

matter the style.

- n. The type and color of materials should be kept to a minimum, preferably three (3) or fewer.
- o. Two (2) or more wall materials should be combined only one above the other, except for bay windows.
- p. Wall materials appearing heavier in weight should be used below wall materials appearing lighter in weight (wood and metal above brick, and all three above stone)
- q. Horizontal or vertical board siding or shingles, regardless of material, should be avoided.
- r. Architectural details and finish materials for the base of a building should be constructed of architectural concrete or pre-cast cementitious panels, natural or cast stone, heavy gauge metal panels, glazed or unglazed architectural terracotta, or brick.
- s. Exterior Insulation and Finish Systems (EIFS) should be avoided.

**Figure 4.1.11 (b) Appearance of Two Buildings**



# 4. MID-RISE DISTRICTS

Mid-Rise 3 (MR3)

## 13. Use Provisions

- a. General
  - i. The USE of real property is subject to the provisions of Article 9: USE Provisions of this Ordinance. Where the provisions of this section conflict with those of Article 9, the provisions of Article 9 apply.
  - ii. USE categories are permitted as specified on Table 4.1.13. USE categories that are not identified on Table 4.1.13 are prohibited.
  - iii. All USES must comply with any USE-specific standards applicable for each USE in §9.2 USE Definitions & Limitations.
  - iv. USES permitted by Special Permit require additional DEVELOPMENT review in accordance with §15.2.1 Special Permits.
- b. USE Limitations
  - i. The USE of any GROUND STORY commercial space fronting a PEDESTRIAN STREET, excluding lobbies for UPPER STORY USES, is limited to the following PRINCIPAL USE categories:
    - a). Arts & Creative Enterprise
    - b). Food & Beverage Service
    - c). Retail Sales
    - d). Civic & Institutional
- c. Increases in Density
  - i. Existing structures may not be altered to conflict with number of DWELLING UNITS permitted for each BUILDING TYPE.

**Table 4.1.13 Permitted Uses**

Use Category Specific Use	MR3
<b>Arts &amp; Creative Enterprise</b>	
Artisinal Production	P
Arts Exhibition	P
Arts Sales & Services	P
Co-working	P
Design Services	P
Shared Workspaces & Arts Education	P
<b>Cannabis Establishment</b>	
Cannabis Cultivation	P
Cannabis Retail Sales	SP
Cannabis Research & Development	P
Cannabis Testing Laboratory	P
<b>Civic &amp; Institutional</b>	
Community Center	P
Hospital	SP
Library	P
Minor Utility Facility	SP
Museum	P
Private Non-Profit Club or Lodge	SP
Public Service	P
Religious & Educational Uses Protected by M.G.L 40A. Sec 3	P

P - Permitted    SP - Special Permit Required    N - Not Permitted

**Table 4.1.13 Permitted Uses (continued)**

Use Category Specific Use	MR3
<b>Commercial Services</b>	
Animal Services (as noted below)	--
Commercial Kennel	SP
Pet Grooming	P
Pet Daycare & Training	SP
Veterinarian	SP
Assembly or Entertainment	SP
Banking & Financial Services (except as follows)	P
Personal Credit	SP
Broadcast and/or Recording Studio	P
Building & Home Repair Services	SP
Business Support Services	P
Caterer/Wholesale Food Production	SP
Day Care Service (as noted below)	--
Adult Day Care Center	P
Child Day Care Center	P
Educational Services	P
Maintenance & Repair of Consumer Goods	P
Personal Services (except as follows)	P
Body-Art Services	SP
Fitness Services	P
Funeral Services	SP
Health Care Services	SP
Formula Personal Services	SP
Recreation Services	SP
Vehicle Parking, Commercial (except as follows)	--
Bike Share Parking	P
Car Share Parking (3 or fewer spaces)	P
Car Share Parking (4 or more spaces)	P
Commercial Parking	P
<b>Food and Beverage Service</b>	
Bar/Restaurant/Tavern	P
Bakery/Café/Coffee Shop	P
Formula Food & Beverage Service	SP

P - Permitted    SP - Special Permit Required    N - Not Permitted

**Table 4.1.13 Permitted Uses (continued)**

Use Category Specific Use	MR3
<b>Lodging</b>	
Bed & Breakfast	SP
Hotel or Hostel	SP
<b>Office</b>	
General Office	P
Research and Development or Laboratory	P
<b>Residential</b>	
Household Living	SP
Group Living (except as follows)	SP
Community or Group Residence	P
Dormitory, Fraternity or Sorority	SP
Homeless Shelter	SP
Nursing Home/Assisted Living Facility	SP
Rooming House	SP
<b>Retail Sales</b>	
Building/Home Supplies & Equipment	SP
Consumer Goods (except as follows)	P
Alcohol Sales	SP
Firearms Sales	N
Pet Store	SP
Formula Retail	SP
Fresh Food Market or Grocery Store	P
Farm/Vendor Market	P
<b>Urban Agriculture</b>	
Farming (as noted below)	--
Commercial Farming	P
Community Farming	P
Community Gardening	P

P - Permitted    SP - Special Permit Required    N - Not Permitted

# 4. MID-RISE DISTRICTS

Mid-Rise 3 (MR3)

**Table 4.1.13 Permitted Uses (continued)**

Use Category Specific Use	MR3
<b>Accessory Uses</b>	
<b>Home Occupations (as noted below)</b>	--
Creative Studio	N
Hobby Kennel	N
Home-Based Business	N
Home Day Care	N
Home Office	P
<b>Urban Agriculture (as noted below)</b>	--
Apiculture	P
Aviculture	P
Commercial Farming	P
Residential Gardening	P
<b>Vehicle Parking, Accessory (except as follows)</b>	P
Home Business Vehicle Parking	N

P - Permitted    SP - Special Permit Required    N - Not Permitted

## 14. Development Standards

- a. General
  - i. DEVELOPMENT is subject to the provisions of Article 10: DEVELOPMENT Standards of this Ordinance. Where the provisions of this section conflict with those of Article 10, the provisions of Article 10 apply.
- b. SIGNS
  - i. A SIGN, individual numerals or letters, or a nonelectrical nameplate identifying the property address is required for all real property as follows:
    - a). Each GROUND STORY non-residential USE must identify the STREET address either on the PRINCIPAL ENTRANCE door or above or beside the PRINCIPAL ENTRANCE of the USE.
    - b). All residential BUILDING TYPES must identify the STREET address either on the PRINCIPAL ENTRANCE door, above or beside the PRINCIPAL ENTRANCE, or on a mailbox.
  - ii. Address SIGNS must be made easily visible through the USE of colors or materials that contrast with the background material they are attached to and must be conspicuously located to provide visibility from the THOROUGHFARE that the building faces.
  - iii. Address SIGNS must be twelve (12) inches in height or less and may include the name of the occupant.

**15. Parking & Mobility**

- a. General
  - i. DEVELOPMENT is subject to the provisions of Article 11: Parking & Mobility of this Ordinance. Where the provisions of this section conflict with those of Article 11, the provisions of Article 11 apply.
  - ii. Vehicular parking must be provided as specified on Table 4.1 (d), except as follows:
    - a). Non-residential USES with five thousand (5,000) square feet or less of GROSS LEASABLE FLOOR AREA are exempt from any minimum requirements of Table 4.1. (d).
    - b). Any CHANGE IN USE within a non-residential structure constructed before the effective date of this Ordinance, provided that the change is to a permitted USE, is exempt from any minimum requirements of Table 4.1 (d).
  - iii. There are no parking requirements for ACCESSORY USES.
  - iv. Motor vehicle parking spaces may be shared between USES on the same LOT and buildings on the same BLOCK in accordance with §11.3 SHARED PARKING.
- b. Type
  - i. Motor vehicle parking may be provided as SURFACE PARKING, above ground STRUCTURED PARKING, and underground STRUCTURED PARKING.
- c. Driveways
  - i. New driveways require a permit from the City Engineer.
  - ii. Driveways must be compliant with all City Ordinances and constructed in accordance with all standards established by relevant City Departments.
  - iii. Driveways are not permitted in the FRONTAGE AREA between a building and the FRONT LOT LINE.
  - iv. Driveways may be no wider than twelve (12) feet in the FRONTAGE AREA OF A LOT.
  - v. Driveways may provide ACCESS in whole or in part on or across an ABUTTING LOT(s), provided that an ACCESS EASEMENT exists between all PROPERTY OWNERS.
- d. Parking Design
  - i. The design of all parking is subject to §11.1 Bicycle Parking and §11.2 Motor Vehicle Parking of this Ordinance.
- e. Parking Location
  - i. Required vehicular parking, excluding any required handicapped parking, may be provided on a contiguous LOT under the same ownership as the LOT that the parking will serve as follows:
    - a). Pedestrian ACCESS to off-SITE vehicular parking must be via a paved sidewalk or walkway.
    - b). A lease, recorded covenant, or other comparable legal instrument guaranteeing long

- term USE of the SITE must be provided to the review board or BUILDING OFFICIAL and executed and filed with the Registry of Deeds.
- ii. For real property located in more than one municipality, motor vehicle parking need not be located within the City of Somerville.
- f. Unbundled Parking
  - i. Motor vehicle parking spaces must be rented or leased as an option rather than a requirement of the rental, lease, or purchase of a DWELLING UNIT or non-residential floor space.
  - ii. Bicycle parking must be provided at no cost or fee to customers, visitors, employees, tenants, and residents.
- g. Parking Relief
  - i. Relief from the parking standards of Table 4.1 (d) requires a special permit.
    - a). In addition to the review criteria for all Special Permits specified in §15.2.1.e. Review Criteria, the review board shall make findings considering the following in its discretion to approve or deny a special permit authorizing relief from the parking standards of Table 4.1 (d):
      - i). The supply and demand of on-STREET parking in the neighborhood, as determined through a parking study.
      - ii). MOBILITY MANAGEMENT programs and services provided by the APPLICANT to reduce the demand for parking.
      - iii). That parking provided in excess of any maximum permitted does not result in the increase in impervious LOT AREA.

**16. Public Realm**

- a. Sidewalks
  - i. When DEVELOPMENT OCCURS on any LOT ABUTTING a sidewalk that is less than twelve (12) feet in total width, the building must be set-back an additional distance to accommodate expansion of the ABUTTING sidewalk to a width of at least twelve (12) feet. The minimum and maximum front SETBACKS for each BUILDING TYPE are increased accordingly.
- b. Sidewalk CURB CUTS
  - i. A CURB CUT requires a permit from the City Engineer and must be compliant with all City Ordinances.
  - ii. Unless otherwise specified, the City Engineer may not permit more than one (1) CURB CUT per FRONT LOT LINE of a LOT.
  - iii. CURB CUTS are prohibited along all THOROUGHFARES designated as a PEDESTRIAN STREET.
  - iv. CURB CUTS must be located to minimize conflicts with pedestrians and bicyclists and must have a clear distance from fire hydrants, STREET TREES, utility



# 4. MID-RISE DISTRICTS

Mid-Rise 3 (MR3)

**Table 4.1.15 Vehicular Parking**

Use Category Specific Use	BICYCLE		MOTOR VEHICLE	
	Short-Term (min)	Long-Term (min)	Within a TRANSIT AREA <sup>1</sup> (max)	Outside of a TRANSIT AREA <sup>1</sup> (min)
<b>Arts &amp; Creative Enterprise</b>				
All Permitted Uses	1 / 10,000 sf	1 / 3,000 sf	1 / 800 sf	1 / 1,000 sf
<b>Cannabis Establishment</b>				
Cannabis Retail Sales	1 / 2,500 sf	1 / 10,000 sf	1 / 1,500 sf	1 / 750 sf
Cannabis Research & Development	1 / 20,000 sf	1 / 5,000 sf	1 / 1,000 sf	1 / 1,000 sf
Cannabis Testing Laboratory	1 / 20,000 sf	1 / 5,000 sf	1 / 1,000 sf	1 / 1,000 sf
<b>Civic &amp; Institutional</b>				
Community Center	1 / 10,000 sf	4 / 10,000 sf	1 / 1,800 sf	1 / 600 sf
Educational Facility	1.0 / classroom	4.0 / classroom	1.5 / classroom	3.0 / classroom
Hospital	10 per entrance	1 / 5,000 sf	1 / 200 sf	1 / 1,000 sf
Library	1 / 3,000 sf	1 / 5,000 sf	1 / 800 sf	1 / 500 sf
Minor Utility Facility	n/a	n/a	n/a	n/a
Museum	1 / 2,000 sf	1 / 10,000 sf	1 / 800 sf	1 / 500 sf
Private Non-Profit Club or Lodge	1 / 2,000 sf	1 / 10,000 sf	1 / 200 sf	1 / 1,000 sf
<b>Commercial Services</b>				
Animal Services (as noted below)	–	–	–	–
Commercial Kennel	1 / 2,500 sf	1 / 10,000 sf	1 / 500 sf	1 / 500 sf
Pet Grooming	1 / 2,500 sf	none	1 / 500 sf	1 / 500 sf
Pet Day Care or Training	1 / 2,500 sf	none	1 / 500 sf	1 / 500 sf
Veterinarian	1 / 2,500 sf	1 / 5,000 sf	1 / 500 sf	1 / 500 sf
Assembly or Entertainment	1 / 40 seats	1 / 10,000 sf	1 / 6 seats	1 / 6 seats
Banking & Financial Services (except as noted below)	1 / 2,000 sf	1 / 10,000 sf	1 / 450 sf	1 / 400 sf
Broadcast and/or Recording Studio	1 / 2,500 sf	1 / 10,000 sf	1 / 800 sf	1 / 600 sf
Building & Home Repair Services	1 / 2,500 sf	1 / 10,000 sf	1 / 1,000 sf	1 / 2,000 sf
Business Support Services	1 / 2,500 sf	1 / 10,000 sf	1 / 900 sf	1 / 600 sf
Caterer/Wholesale Food Production	1 / 2,500 sf	1 / 10,000 sf	1 / 800 sf	1 / 1,000 sf
Day Care Service	2	1 / 10,000 sf	1 / 900 sf	1 / 600 sf
Maintenance & Repair of Consumer Goods	1 / 2,500 sf	1 / 10,000 sf	1 / 750 sf	1 / 1,000 sf
Personal Services (except as noted below)	1 / 2,500 sf	1 / 10,000 sf	1 / 750 sf	1 / 1,000 sf
Health Care Services	1 / 2,000 sf	1 / 10,000 sf	1 / 500 sf	1 / 300 sf
Recreation Services	1 / 2,500 sf	1 / 10,000 sf		

sf - Gross Leasable Square Footage      DU - Dwelling Unit      RU - Rooming Unit

<sup>1</sup> See the Transit Area Map



**Table 4.1.15 Vehicular Parking (continued)**

\*See Transit Orientation Map for distance to a TRANSIT STATION

Use Category Specific Use	BICYCLE		MOTOR VEHICLE	
	Short-Term (min)	Long-Term (min)	Within a TRANSIT AREA <sup>1</sup> (max)	Outside of a TRANSIT AREA <sup>1</sup> (min)
<b>Food and Beverage Service</b>				
All Permitted Uses	1 / 1,000 sf	1 / 5,000 sf	1 / 300 sf	1 / 500 sf
<b>Lodging</b>				
Bed & Breakfast	n/a	2	1 / DU + 1 / 4 guest rooms	1 / DU + 1 / 4 guest rooms
Hotel or Hostel	1 / 20 rooms	1 / 10 rooms	1 / 2 rooms	1 / 2 rooms
<b>Office</b>				
Co-Working	1 / 20,000 sf	1 / 3,000 sf	1 / 1,200 sf	1 / 800 sf
General Office	1 / 20,000 sf	1 / 3,000 sf	1 / 900 sf	1 / 650 sf
Research and Development or Laboratory	1 / 20,000 sf	1 / 5,000 sf	1 / 1,000 sf	1 / 1,000 sf
<b>Residential</b>				
Household Living	0.1 / DU	1.0 / DU	1.0 / DU	1.0 / DU
Group Living (except as follows)	0.05 / RU	0.5 / RU	–	–
Community or Group Residence	–	–	–	–
Dormitory, Fraternity or Sorority	0.1 / bed	0.5 / bed	.05 / bed	1.0 / 4 beds
Homeless Shelter	–	–	4.0	4.0
Nursing Home/Assisted Living Facility	–	–	1 / 6 beds	1 / 6 beds
Single Room Occupancy Housing	–	–	1 / 6 beds	1 / 4 beds
<b>Retail Sales</b>				
Building/Home Supplies & Equipment	1 / 2,500 sf	1 / 10,000 sf	1 / 1,000 sf	1 / 1,000 sf
Consumer Goods (except as follows)	1 / 2,500 sf	1 / 10,000 sf	1 / 1,500 sf	1 / 750 sf
Formula Retail	1 / 2,500 sf	1 / 10,000 sf	1 / 1,500 sf	1 / 750 sf
Fresh Food Market or Grocery Store	1 / 1,000 sf	1 / 10,000 sf	1 / 500 sf	1 / 1,500 sf
Farm/Vendor Market	n/a	n/a	n/a	1 / 1,500 sf

sf - Gross Leasable Square Footage      DU - Dwelling Unit      RU - Rooming Unit

<sup>1</sup> See the Transit Area Map

## 4. MID-RISE DISTRICTS

### Mid-Rise 3 (MR3)

poles, and other furnishings as deemed necessary by the City Engineer.

- a). CURB CUTS for commercial or high-volume driveways should be at least one-hundred (100) feet from an UNSIGNALIZED or SIGNALIZED intersection.
- b). CURB CUTS for residential driveways should be at least twenty (20) feet from an UNSIGNALIZED intersection and at least forty (40) feet from a SIGNALIZED intersection.
- v. The interior width of a CURB CUT (between curb stones) may be no wider than the driveway, vehicular entrance, or loading facility it serves.
- vi. A DRIVEWAY APRON may be installed only within the furnishing zone of a sidewalk and must be constructed in accordance with all standards established by relevant City Departments.
- vii. The grade, cross slope, and clear width of the walkway of a sidewalk must be maintained between the DRIVEWAY APRON and the ABUTTING driveway. The appearance of the walkway (ie. scoring pattern or paving material) must indicate that, although a vehicle may cross, the area traversed by a vehicle remains part of the sidewalk.

**Figure 4.1.17 Sidewalk Curb Cuts**

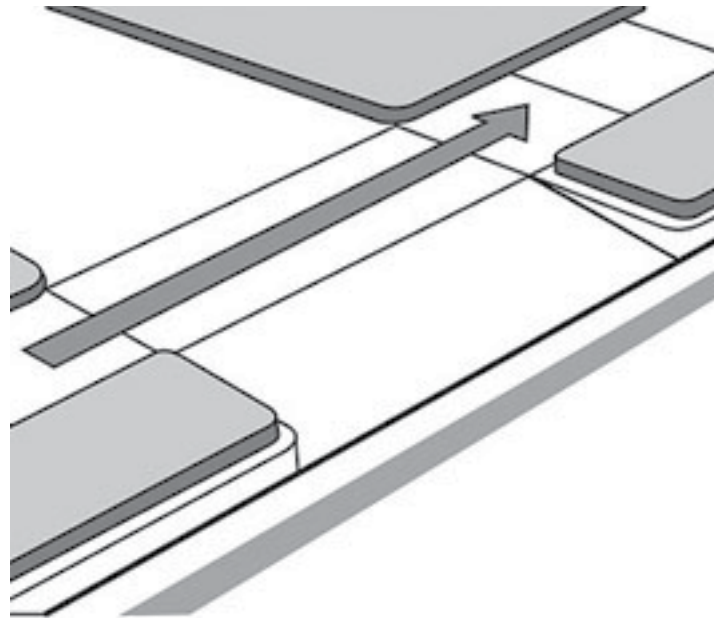

## 4.2 MID-RISE 4 (MR4)

### 1. Character Description

The Mid-Rise 4 district is characterized by a variety of moderate FLOOR PLATE buildings up to four (4) stories in height. Buildings are set close to the sidewalk to create a defined STREET wall that supports pedestrian activity

and a sense of place. The district is primarily commercial, with GROUND STORY USES that typically address the needs of residents and employees in the immediate neighborhood.



## 4. MID-RISE DISTRICTS

### Mid-Rise 4 (MR4)

#### 2. Intent

- a. To implement the objectives of the COMPREHENSIVE PLAN of the City of Somerville.
- b. To create, maintain, and enhance areas appropriate for smaller scale, multi-USE and mixed-USE buildings and neighborhood serving USES.

#### 3. Purpose

- a. To permit the DEVELOPMENT of multi-unit and mixed-USE buildings that do not exceed four (4) stories in height.
- b. To provide quality commercial spaces and permit small-scale, neighborhood serving commercial USES.
- c. To create DWELLING UNIT types, sizes, and BEDROOM counts ideal for larger households in apartment buildings.
- d. To create DWELLING UNIT types, sizes, and BEDROOM counts ideal for smaller households in general buildings.
- e. To permit increased residential density for buildings that are sustainable or that provide 100% AFFORDABLE HOUSING.
- f. To permit increased residential density for buildings that meet the definition of a NET ZERO BUILDING or 100% AFFORDABLE HOUSING.

#### 4. Applicability

- a. The section is applicable to all real property within the Mid-Rise 4 district as shown on the maps of the Official Zoning Atlas of the City of Somerville.

#### 5. Development Review

- a. DEVELOPMENT review is subject to the provisions of Article 15: Administration of this Ordinance.
- b. All DEVELOPMENT, excluding NORMAL MAINTENANCE, requires the submittal of a development review application to the BUILDING OFFICIAL and the issuance of a Certificate of Zoning Compliance prior to the issuance of a Building Permit or Certificate of Occupancy.
- c. Proposed DEVELOPMENT may or may not necessitate the need for SUBDIVISION Plan Approval, Site Plan Approval, a Special Permit, or a Hardship Variance based on the nature of the proposal. In such cases, additional DEVELOPMENT review is required in accordance with Article 15: Administration.
  - i. The Planning Board is the decision making authority for all DEVELOPMENT that requires Site Plan Approval or a Special Permit.
  - ii. The Zoning Board of Appeals is the Review Board for all HARSHIP Variances.
- d. Upon verification that no additional DEVELOPMENT review is necessary, or completion of the required DEVELOPMENT review, the BUILDING OFFICIAL shall issue a Zoning Compliance Certificate to certify compliance with the provisions and procedures of this Ordinance.

#### 6. Building Types

- a. One (1) PRINCIPAL BUILDING TYPE is permitted on each LOT.
- b. The following BUILDING TYPES are permitted by Site Plan Approval in the Mid-Rise 4 district:
  - i. Apartment Building
  - ii. General Building
  - iii. Commercial Building
- c. Apartment Buildings are prohibited on any LOT fronting a PEDESTRIAN STREET.
- d. ACCESSORY structures are regulated according to Article 10: DEVELOPMENT Standards of this Ordinance.



## 4.2.7 Apartment Building

A moderate FLOOR PLATE, multi-STORY, PRINCIPAL BUILDING TYPE purpose built for OCCUPATION by residential USES on all stories.

The following images are examples of the apartment BUILDING TYPE and are intended only for illustrative purposes.



[Version Notes:](#)  
§4.2.3.c deleted from previous version

# 4. MID-RISE DISTRICTS

Mid-Rise 4 (MR4)

## 4.2.7. Apartment Building (continued)

a. Lot Standards

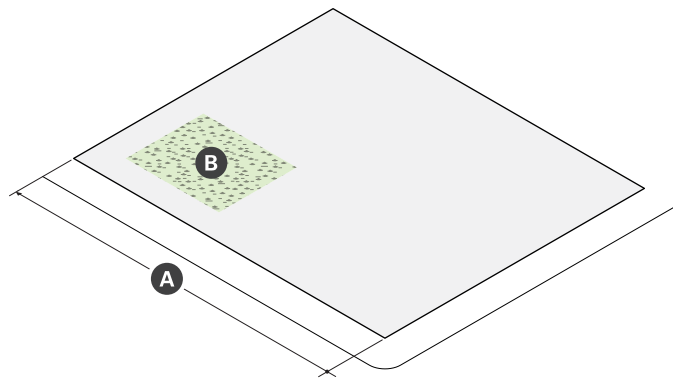

Lot Dimensions	
<b>A</b> LOT WIDTH (min)	30 ft

Lot Development	
LOT Coverage (max)	90%
GREEN SCORE	--
Minimum	0.25
Ideal	0.30
<b>B</b> OPEN SPACE (min)	15%

b. BUILDING Placement

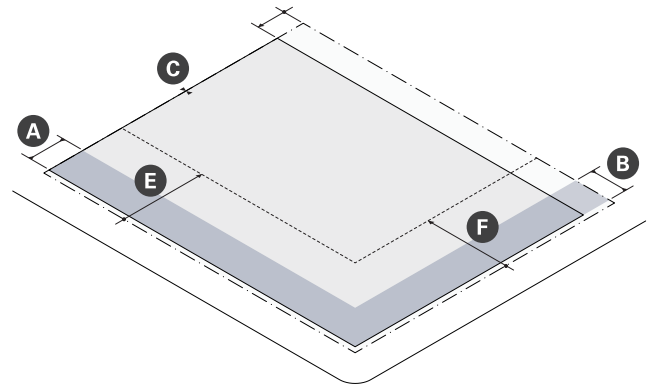

Building Setbacks		
<b>A</b> Primary Front SETBACK (min/max)	2 ft	12 ft
<b>B</b> Secondary Front SETBACK (min/max)	2 ft	12 ft
<b>C</b> Side SETBACK (min)	0 ft	
Side SETBACK ABUTTING NR or LHD (min)	10 ft	
<b>D</b> Rear SETBACK (min)	--	
ALLEY	0 ft	
No ALLEY	10 ft	
No ALLEY & ABUTTING NR or LHD	15 ft	

Parking Setbacks	
<b>E</b> Primary Front SETBACK (min)	--
SURFACE PARKING	30 ft
STRUCTURED PARKING	30 ft
<b>F</b> Secondary Front SETBACK (min)	--
SURFACE PARKING	10 ft
STRUCTURED PARKING	2 ft



## 4.2.7. Apartment Building (continued)

### c. Massing & Height

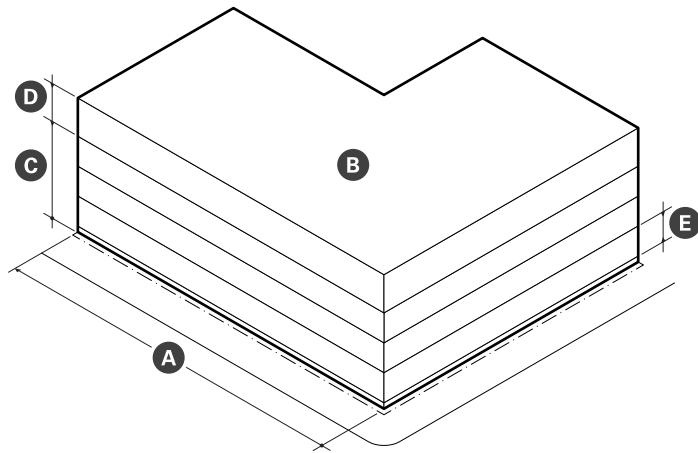

Main Massing	
<b>A</b> BUILDING WIDTH (max)	200 ft
FACADE Build Out (min)	–
Primary Front	80%
Secondary Front	65%
<b>B</b> FLOOR PLATE (max)	15,000 sf
GROUND STORY Elevation (min)	2 ft
<b>C</b> STORY Height (min)	10 ft
<b>D</b> Number of Stories (min/max)	3   4
<b>E</b> BUILDING Height, Feet (max)	50 ft
Roof Type	Flat

### d. Uses & Features

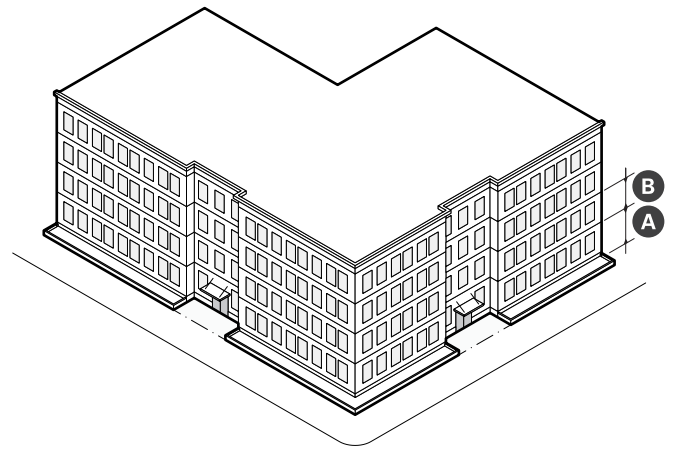

Facade Composition	
<b>A</b> GROUND STORY FENESTRATION (min/max)	20% 50%
<b>B</b> UPPER STORY FENESTRATION (min/max)	20% 50%
BLANK WALL (max)	20 ft

Use & Occupancy	
GROSS FLOOR AREA per DU	–
LOT AREA < 5,500 sf	1,500
LOT AREA >= 5,500 sf	1,125
NET ZERO BUILDING	850
100% AFFORDABLE HOUSING	850
Outdoor AMENITY SPACE (min)	1/DU

# 4. MID-RISE DISTRICTS

Mid-Rise 4 (MR4)

## 4.2.7. Apartment Building (continued)

- e. DEVELOPMENT Benefits
  - i. DEVELOPMENT is subject to the provisions of Article 12: DEVELOPMENT Benefits of this Ordinance. Where the provisions of this section conflict with those of Article 12, the provisions of Article 12 apply.
  - ii. DEVELOPMENT of a general building must provide AFFORDABLE DWELLING UNITS as specified on Table 4.2.7.
- f. Design Guidelines
  - i. GROUND STORY DWELLING UNITS should be elevated above the grade of any adjacent sidewalk so that the window sills of the DWELLING UNIT are at or above the eye-level of passing pedestrians. This elevation change maintains privacy for occupants while also encouraging open blinds or curtains to allow natural daylight into the unit.
  - ii. FENESTRATION patterns and window configurations should break the direct line of sight between neighboring properties to every extent practicable. Translucent glass on the bottom half of windows or strategically placed landscape elements should be utilized if it is not practical to off-set windows in such a way as to minimize privacy impacts.
  - iii. Outdoor AMENITY SPACES that are elevated, such as roof DECKS, fully projecting balconies, and UPPER STORY rear porches should, provide sight-obscuring visual screening at the sides to increase privacy, security, and to limit views of ABUTTING properties from elevated vantage points.

**Table 4.2.7 Required ADUs**

Total DWELLING UNITS	Required ADUs
0 to 5 units	None
6 units	1 unit OR fractional buyout for 0.4 units
7 units	1 unit OR fractional buyout for 0.6 units
8 to 17 units	17.5% of units
18 or more units	20% of units

## 4.2.8 General Building

A moderate FLOOR PLATE, multi-STORY PRINCIPAL BUILDING TYPE with GROUND STORY commercial space and no limitations on the occupancy of UPPER STORIES for permitted USES. The UPPER STORIES of a general BUILDING are typically residential, but a wide variety exists. As the number of stories increases, it becomes more likely for the UPPER STORIES of a general BUILDING to host commercial USES as well as residential.

The following images are examples of the general BUILDING TYPE and are intended only for illustrative purposes.



# 4. MID-RISE DISTRICTS

Mid-Rise 4 (MR4)

## 4.2.8. General Building (continued)

a. Lot Standards

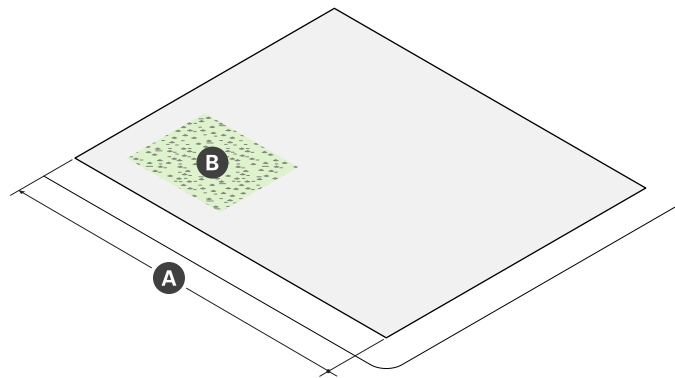

Lot Dimensions	
<b>A</b> LOT WIDTH (min)	30 ft

Lot Development	
LOT Coverage (max)	90%
GREEN SCORE	--
Minimum	0.25
Ideal	0.30
<b>B</b> OPEN SPACE (min)	15%

b. BUILDING Placement

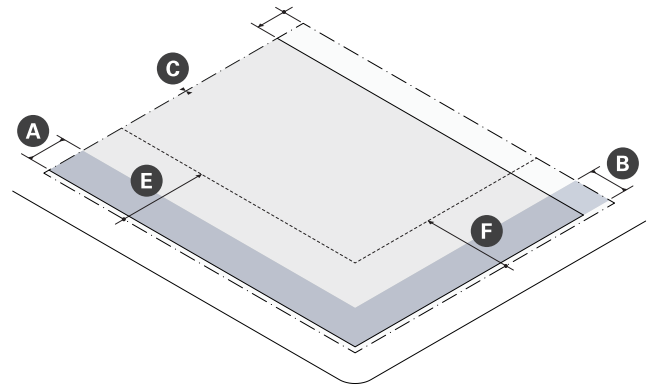

Building Setbacks		
<b>A</b> Primary Front SETBACK (min/max)	2 ft	15 ft
<b>B</b> Secondary Front SETBACK (min/max)	2 ft	15 ft
<b>C</b> Side SETBACK (min)	0 ft	
Side SETBACK ABUTTING NR or LHD (min)	10 ft	
<b>D</b> Rear SETBACK (min)	--	
ALLEY	0 ft	
No ALLEY	10 ft	
No ALLEY & ABUTTING NR or LHD	15 ft	

Parking Setbacks	
<b>E</b> Primary Front SETBACK (min)	--
SURFACE PARKING	30 ft
STRUCTURED PARKING	30 ft
<b>F</b> Secondary Front SETBACK (min)	--
SURFACE PARKING	10 ft
STRUCTURED PARKING	2 ft

## 4.2.8. General Building (continued)

### c. Massing & Height

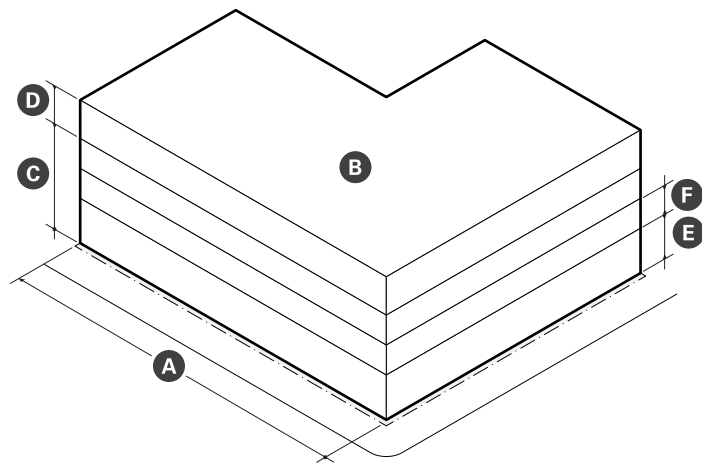

Main Massing	
<b>A</b> BUILDING WIDTH (max)	200 ft
FACADE Build Out, Primary Front (min)	–
Primary Front	80%
Secondary Front	65%
<b>B</b> FLOOR PLATE (max)	15,000 sf
<b>C</b> GROUND STORY Height (min)	14 ft
<b>D</b> UPPER STORY Height (min)	10 ft
<b>E</b> Number of Stories (min)	3   4
<b>F</b> BUILDING Height, Feet (max)	55 ft
Roof Type	Flat

### d. Uses & Features

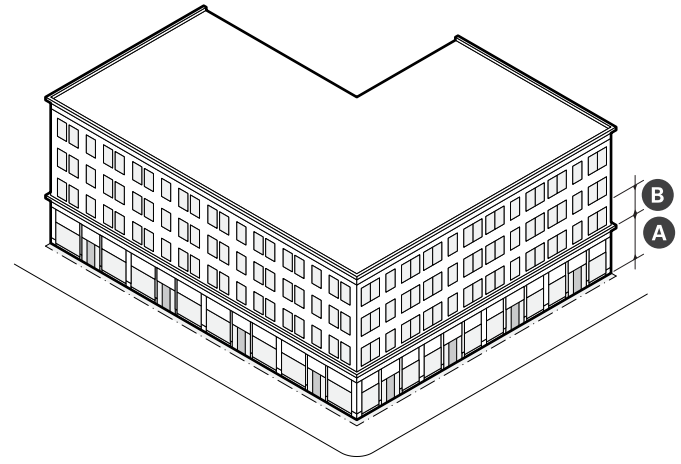

Facade Composition	
<b>A</b> GROUND STORY FENESTRATION (min)	70%
<b>B</b> UPPER STORY FENESTRATION (min/max)	20%   50%
BLANK WALL (max)	20 ft

Use & Occupancy	
GROUND STORY Entrance Spacing (max)	30 ft
Commercial Space Depth (min)	30 ft
GROSS FLOOR AREA per DU	–
LOT AREA < 5,500 sf	1,500
LOT AREA >= 5,500 sf	1,125
NET ZERO BUILDING	850
100% AFFORDABLE HOUSING	850
Outdoor AMENITY SPACE (min)	1/DU

# 4. MID-RISE DISTRICTS

Mid-Rise 4 (MR4)

## 4.2.8. General Building (continued)

- e. DEVELOPMENT Benefits
  - i. DEVELOPMENT is subject to the provisions of Article 12: DEVELOPMENT Benefits of this Ordinance. Where the provisions of this section conflict with those of Article 10, the provisions of Article 10 apply.
  - ii. DEVELOPMENT of a general building must provide AFFORDABLE DWELLING UNITS as specified on Table 4.2.8 (a).
  - iii. DEVELOPMENT of a general building must provide linkage payments as specified on Table 4.2.8 (b).
- f. Design Guidelines
  - i. FENESTRATION patterns and window configurations should break the direct line of sight between neighboring properties to every extent practicable. Translucent glass on the bottom half of windows or strategically placed landscape elements should be utilized if it is not practical to off-set windows in such a way as to minimize privacy impacts.
  - ii. Outdoor AMENITY SPACES that are elevated, such as roof DECKS, fully projecting balconies, and UPPER STORY rear porches should, provide sight-obscuring visual screening at the sides to increase privacy, security, and to limit views of ABUTTING properties from elevated vantage points.

**Table 4.2.8 (a) Required ADUs**

Total DWELLING UNITS	Required ADUs
0 to 5 units	None
6 units	1 unit OR fractional buyout for 0.4 units
7 units	1 unit OR fractional buyout for 0.6 units
8 to 17 units	17.5% of units
18 or more units	20% of units

**Table 4.2.8 (b) Linkage**

Commercial GROSS FLOOR AREA	Affordable Housing Linkage	Employment Linkage
30,000 sf or less	None	None
Over 30,000 sf	\$10/sf	\$2.46/sf



## 4.2.9 Commercial Building

A moderate FLOOR PLATE, multi-STORY, PRINCIPAL BUILDING TYPE purpose built for occupation by commercial uses on all stories. GROUND STORY commercial space is primarily occupied by commercial service, food & beverage service, or retail sales PRINCIPAL USES. Floor space on upper stories may be occupied by retail uses that do not rely on the visibility of a storefront at sidewalk level.

The following images are examples of the general BUILDING TYPE and are intended only for illustrative purposes.



# 4. MID-RISE DISTRICTS

Mid-Rise 4 (MR4)

## 4.2.9. Commercial Building (continued)

a. LOT Standards

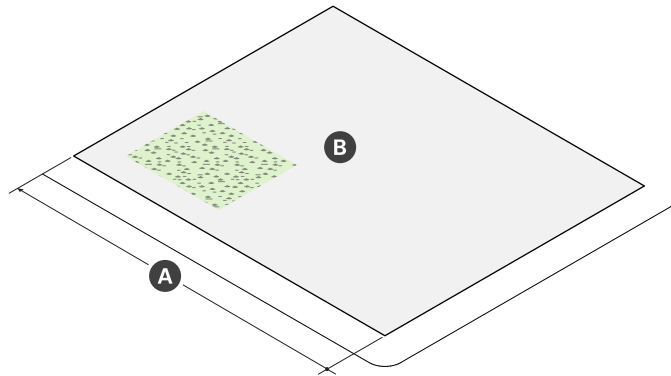

Lot Dimensions	
<b>A</b> LOT WIDTH (min)	30 ft

Lot Development	
LOT Coverage (max)	90%
GREEN SCORE	--
Minimum	0.25
Ideal	0.30
<b>B</b> OPEN SPACE (min)	15%

b. BUILDING Placement

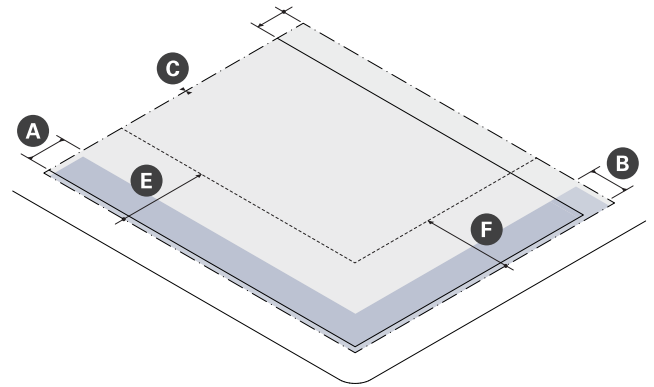

Building Setbacks		
<b>A</b> Primary Front SETBACK (min/max)	2 ft	15 ft
<b>B</b> Secondary Front SETBACK (min/max)	2 ft	15 ft
<b>C</b> Side SETBACK (min)	0 ft	
Side SETBACK ABUTTING NR or LHD (min)	10 ft	
<b>D</b> Rear SETBACK (min)	--	
ALLEY	0 ft	
No ALLEY	10 ft	
No ALLEY & ABUTTING NR or LHD	15 ft	

Parking Setbacks	
<b>E</b> Primary Front SETBACK (min)	--
SURFACE PARKING	30 ft
STRUCTURED PARKING	30 ft
<b>F</b> Secondary Front SETBACK (min)	--
SURFACE PARKING	10 ft
STRUCTURED PARKING	2 ft

## 4.2.9. Commercial Building (continued)

### c. Massing & Height

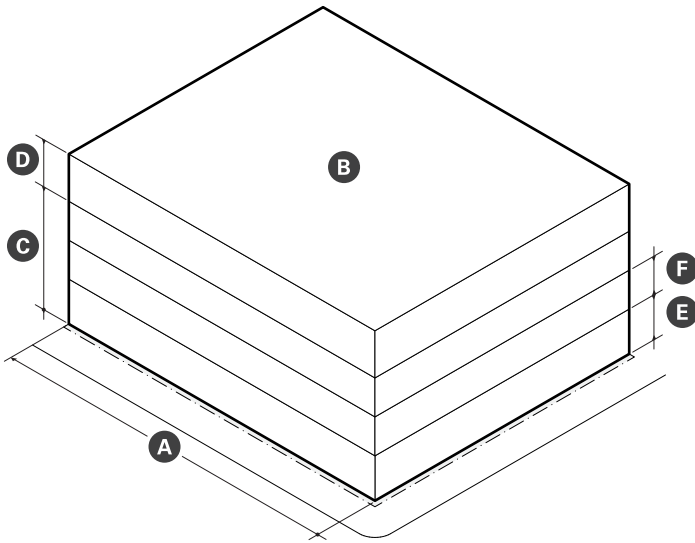

### d. Uses & Features

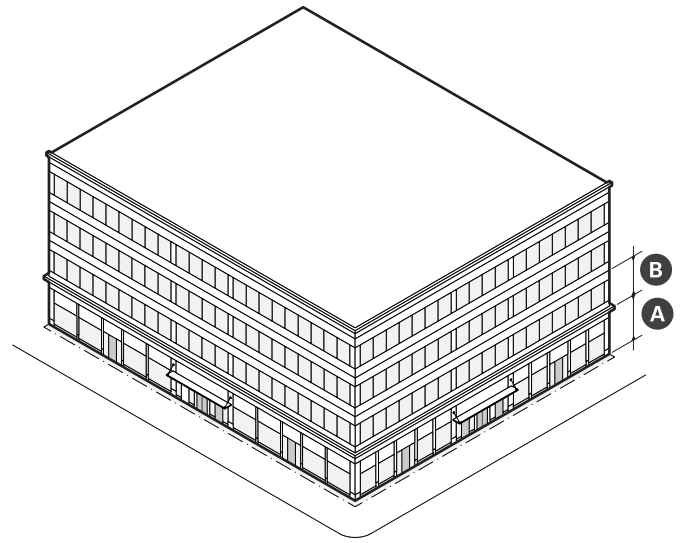

Main Massing	
<b>A</b> BUILDING WIDTH (max)	200 ft
FACADE Build Out, Primary Front (min)	–
Primary Front	80%
Secondary Front	65%
<b>B</b> FLOOR PLATE (max)	15,000 sf
<b>C</b> BUILDING Height, Stories (min)	3 stories
<b>D</b> BUILDING Height, Stories (max)	4 stories
<b>E</b> GROUND STORY Height (min)	14 ft
<b>F</b> UPPER STORY Height (min)	10 ft
BUILDING Height, Feet (max)	65 ft
Roof Type	Flat

Facade Composition	
<b>A</b> GROUND STORY FENESTRATION (min)	70%
<b>B</b> UPPER STORY FENESTRATION (min/max)	20% 70%
BLANK WALL (max)	20 ft

Use & Occupancy	
PRINCIPAL ENTRANCE Spacing (max)	30 ft
Commercial Space Depth (min)	30 ft

## 4. MID-RISE DISTRICTS

Mid-Rise 4 (MR4)

### 4.2.9. Commercial Building (continued)

- e. DEVELOPMENT Benefits
- i. DEVELOPMENT is subject to the provisions of Article 12: DEVELOPMENT Benefits of this Ordinance. Where the provisions of this section conflict with those of Article 12, the provisions of Article 12 apply.
  - ii. DEVELOPMENT of a general building must provide linkage payments as specified on Table 4.2.9.

**Table 4.2.9 Linkage**

<b>Commercial GROSS FLOOR AREA</b>	<b>Affordable Housing Linkage</b>	<b>Employment Linkage</b>
<b>30,000 sf or less</b>	<b>None</b>	<b>None</b>
<b>Over 30,000 sf</b>	<b>\$10/sf</b>	<b>\$2.46/sf</b>

## 10. Building Components

- a. BUILDING COMPONENTS are ACCESSORY elements attached to the MAIN MASSING of a PRINCIPAL BUILDING.
- b. BUILDING COMPONENTS are permitted by Site Plan Approval as specified on Table 4.2.10.
  - i. At least one (1) storefront is required for each GROUND STORY commercial space.
- c. BUILDING COMPONENTS not identified on Table 4.2.10 are prohibited.
- d. Unless otherwise specified, BUILDING COMPONENTS may attach to other BUILDING COMPONENTS to create assemblies of components.

**Table 4.2.10 Building Components**

	Apartment BUILDING	General BUILDING	Commercial BUILDING
Awning	N	P	P
Entry Canopy	P	P	P
Lobby Entrance	P	P	P
Storefront	N	P	P
Stoop	P	N	N
Bay Window	P	P	P
Balcony	P	P	N
Arcade	N	N	N

P - Permitted    SP - Special Permit Required    N - Not Permitted

# 4. MID-RISE DISTRICTS

Mid-Rise 4 (MR4)

## e. Awning

- i. An awning is a wall mounted frame covered with fabric or other material that provides shade and weather protection over a storefront or BUILDING entrance.

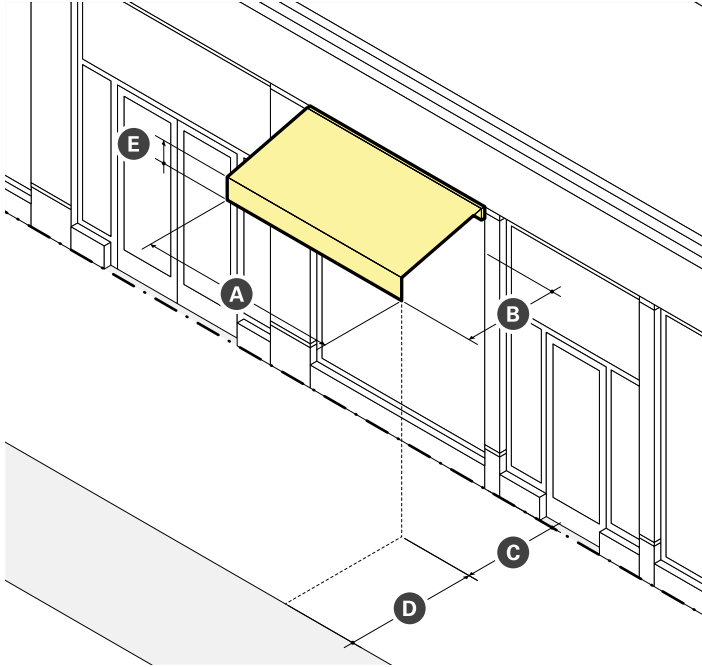

Dimensions	
<b>A</b> Width (min)	See ii Standards
<b>B</b> Projection (min)	3 ft
<b>C</b> CLEARANCE (min)	8 ft
Front SETBACK ENCROACHMENT (max)	100%
<b>D</b> SETBACK from Curb (min)	2 ft
<b>E</b> Valance Height (max)	12 in

- ii. Standards
  - a). Awnings must be securely attached to and supported by the BUILDING and must fit the windows or doors the awning is attached to.
  - b). An awning must be made of durable, weather-resistant material that is water repellent.
  - c). Internally illuminated or back-lit awnings are prohibited.
  - d). An awning that projects over the sidewalk of a public THOROUGHFARE requires compliance with all City Ordinances.

## f. Entry Canopy

- i. An entry canopy is a wall-mounted STRUCTURE that provides shade and weather protection over a storefront or BUILDING entrance.

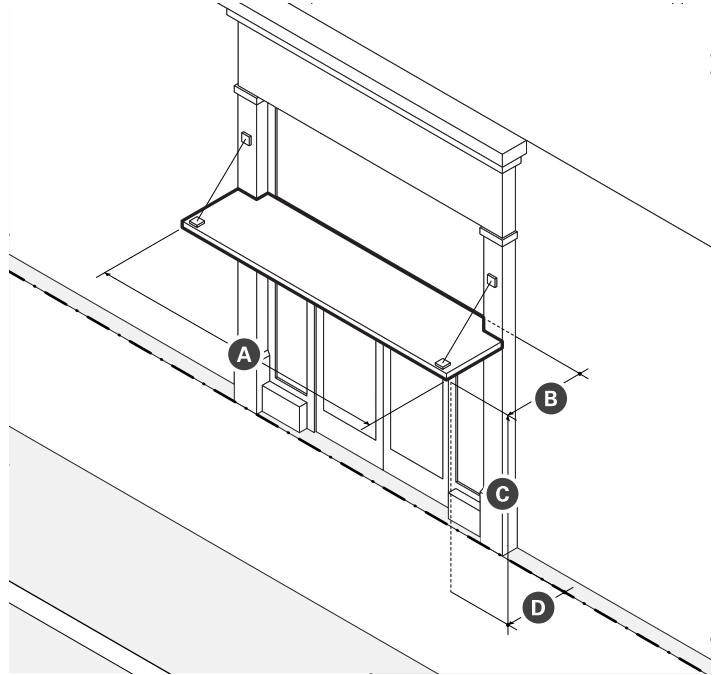

Dimensions	
<b>A</b> Width (min)	See ii Standards
<b>B</b> Projection (min)	3 ft
<b>C</b> CLEARANCE (min)	8 ft
<b>D</b> Front SETBACK ENCROACHMENT (max)	100%
SETBACK from Curb (min)	2 ft

- ii. Standards
  - a). Entry canopies must be visually supported by brackets, cables, or rods.
  - b). The width of an entry canopy must be equal to or greater than the width of the doorway surround or exterior casing it is mounted over.



### g. Lobby Entrance

- i. A lobby entrance is a non-load bearing assembly of entry doors and windows providing ACCESS and light to the lobby of a BUILDING.

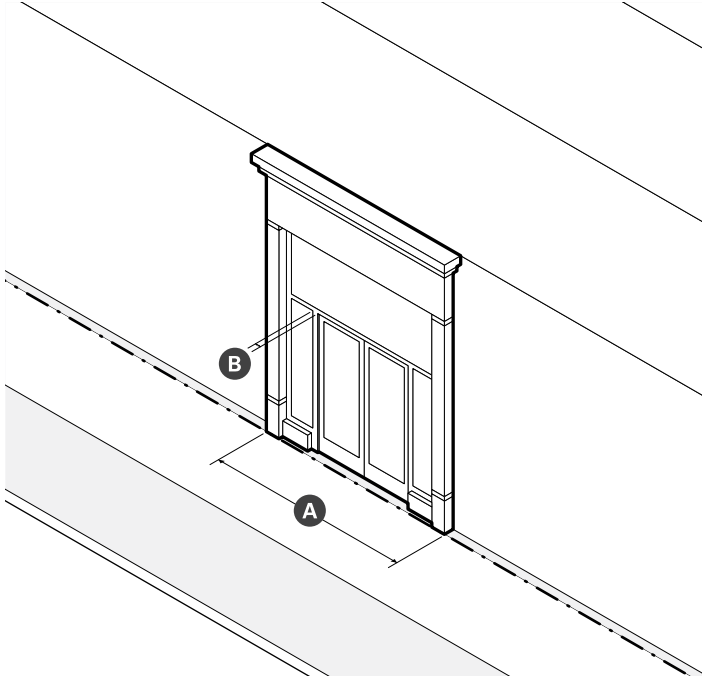

Dimensions		
<b>A</b> Width (min/max)	15 ft	30 ft
<b>B</b> Height (min)	80% of GROUND STORY Height	
Recessed Entrance Width (max)	15 ft	
Recessed Entrance Depth (max)	5 ft	

- ii. Standards
  - a). When a lobby entrance is set back from the FRONT LOT LINE, the FRONTAGE AREA must be paved.

### h. Storefront

- i. A storefront is a non-load bearing assembly of commercial entry doors and windows providing ACCESS and light to a commercial space and a place to display goods, services, and SIGNS.

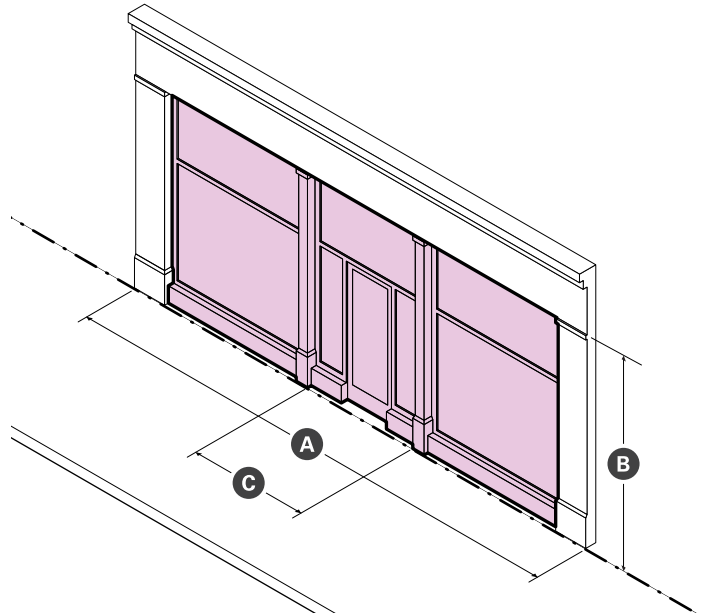

Dimensions		
<b>A</b> Width (min/max)	15 ft	30 ft
<b>B</b> Height (min)	80% of GROUND STORY Height	
Display Window Height (min)	8 ft	
Recessed Entrance Width (max)	15 ft	
Recessed Entrance Depth (max)	5 ft	

- ii. Standards
  - a). An unobstructed view of the interior space or a lighted and maintained merchandise display(s) must be provided for a depth of at least four (4) feet behind storefront display windows.
  - b). When storefronts are set back from the FRONT LOT LINE, the FRONTAGE AREA must be paved.
  - c). When present, awnings and canopies must be mounted between columns, PILASTERS, OR PIERS; above doorways and display windows; and below the SIGN BAND.
  - d). Exterior security grilles, gates, and roll-down security doors and windows are prohibited.

# 4. MID-RISE DISTRICTS

Mid-Rise 4 (MR4)

## i. Stoop

- i. A stoop is a set of stairs with a landing leading to the entrance of a BUILDING.

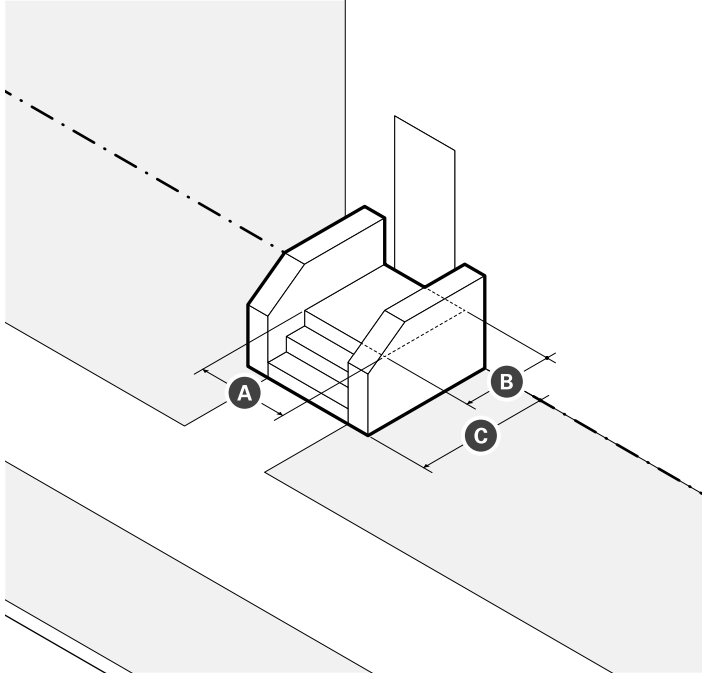

Dimensions	
<b>A</b> Landing Width (min)	4 ft
<b>B</b> Landing Depth (min)	4 ft
<b>C</b> Front SETBACK ENCROACHMENT (max)	100%

- ii. Standards
  - a). Paving, excluding driveways, must match the ABUTTING sidewalk unless paved with pervious, porous, or permeable materials.
  - b). Stairs may be recessed into the BUILDING FACADE when the BUILDING is set back four (4) feet or less.
  - c). Stairs are not permitted to ENCROACH onto any ABUTTING sidewalk.
  - d). Stairs may be built perpendicular or parallel to the BUILDING FACADE, but must lead directly to ground level or an ABUTTING sidewalk.

## j. Bay Window

- i. A bay window is an assembly of windows projecting from a building to provide additional HABITABLE space, increased light, multi-directional views, and ARTICULATION to an exterior wall.

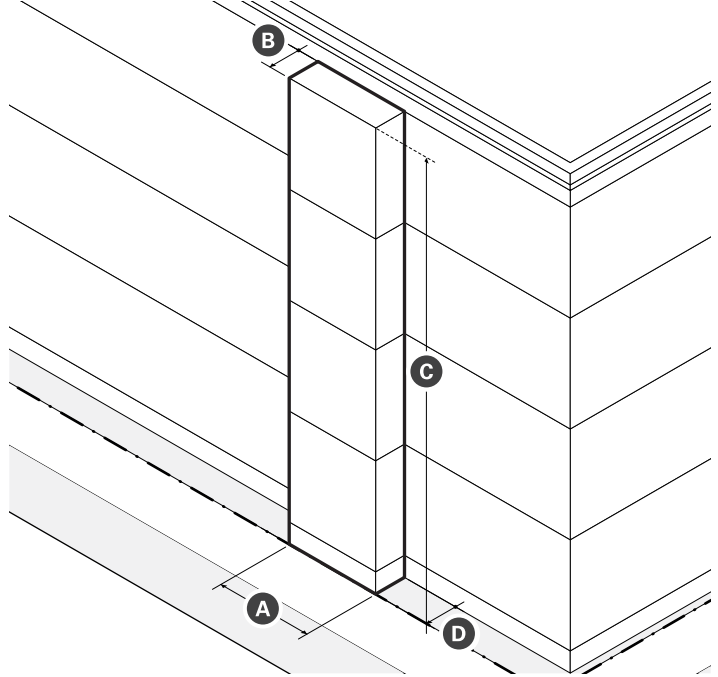

Dimensions	
<b>A</b> Width (max)	16 ft
<b>B</b> Projection (max)	3 ft
<b>C</b> Height (max)	Height of BUILDING in Stories
<b>D</b> Front SETBACK ENCROACHMENT (max)	3 ft
FENESTRATION (min)	60%

- ii. Standards
  - a). Bay windows, including box and bow windows, must include at least three (3) windows.
  - b). The cumulative width of multiple bays may equal up to fifty percent (50%) of the width of the exterior wall from which the bays project.
  - c). Bays projecting over the sidewalk of a public THOROUGHFARE must have at least two (2) stories of CLEARANCE and be compliant with all City Ordinances.

## k. Balcony

- i. A balcony is a platform with a railing that provides outdoor AMENITY SPACE.

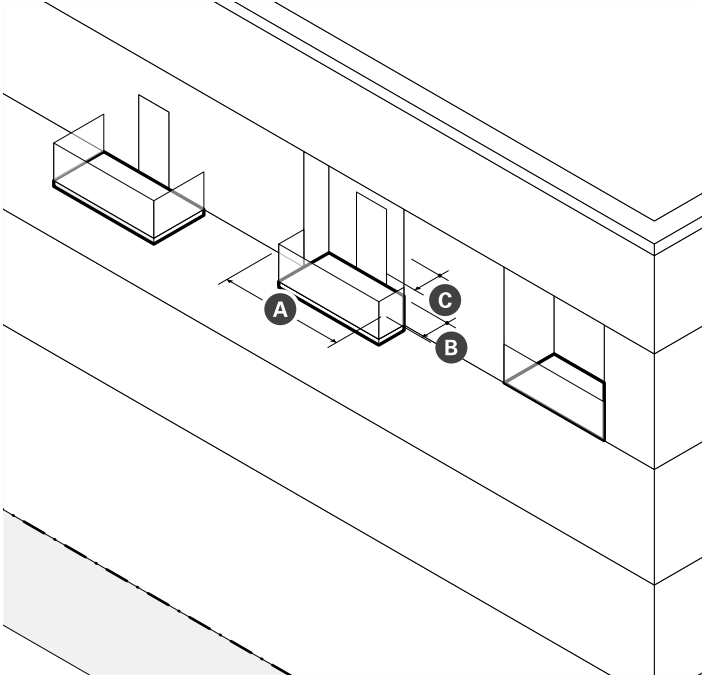

Dimensions	
<b>A</b> Width (min)	5 ft
<b>B</b> Depth (max)	5 ft
<b>D</b> Area (min)	50 ft
CLEARANCE (min)	10 ft
Permitted Front SETBACK ENCROACHMENT (max)	6 ft

- ii. Standards
  - a). Balconies may be recessed, projecting, a combination of the two, or terraced as part of the roof of a portico, porch, or bay.
  - b). A balcony that projects over the sidewalk of a public THOROUGHFARE requires compliance with all City Ordinances.
  - c). The guard rail of any balcony oriented toward a FRONT LOT LINE must permit visual supervision of the PUBLIC REALM through the posts and rails.
  - d). The guard rail of any balcony oriented toward a side OF REAR LOT LINE ABUTTING the NR district must include sight-obscuring visual screening so that it is at least fifty percent (50%) opaque.

## l. Arcade

- i. An arcade is a pedestrian walkway covered by the upper floors of a BUILDING. The GROUND STORY FACADE is SETBACK and upper floors are supported by a colonnade or supports.

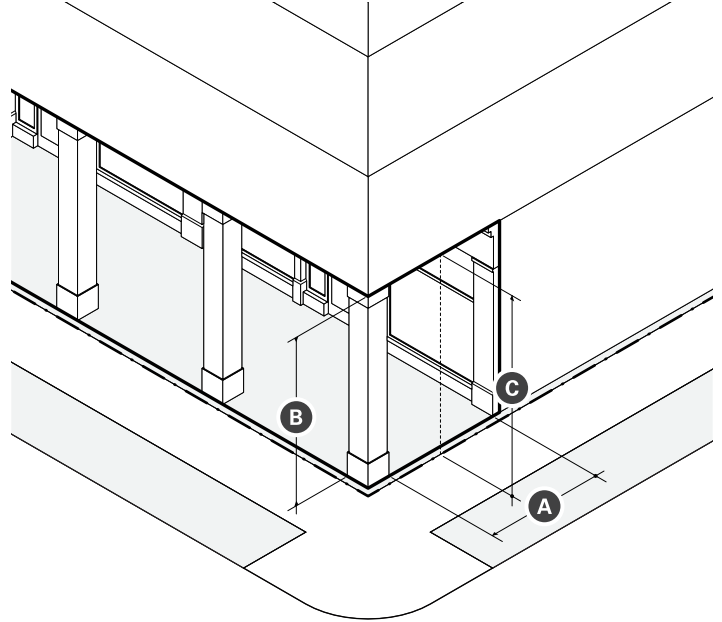

Dimensions		
<b>A</b> Depth (min/max)	10 ft	15 ft
<b>B</b> Height (max)	1 STORY	
<b>C</b> CLEARANCE (min/max)	14 ft	24 ft

- ii. Standards
  - a). Arcades must extend the entire width of a BUILDING and must have a consistent depth.
  - b). Support columns or PIERS may be spaced no farther apart than they are tall.
  - c). Arcades are considered part of the BUILDING for the purpose of measuring FACADE build out.
  - d). Arcades may be combined only with storefront and lobby entrance frontages.
  - e). The finished ceiling of an arcade interior may be arched or flat, but must have a greater CLEARANCE than the openings between columns OR PIERS.

# 4. MID-RISE DISTRICTS

Mid-Rise 4 (MR4)

## 11. Facade Design

- a. FACADES must provide solid material framing each storefront and lobby entrance as follows:
  - i. PILASTERS or columns supporting a horizontal lintel and CORNICE;
  - ii. a spandrel positioned between PILASTERS or columns that extend from upper stories of the building to the ground; or
  - iii. flat wall above and to either side of a void or punched opening.
- b. Storefronts and lobby entrances must be set within the resulting frame provided for each by the FACADE.
- c. Materials framing each storefront or lobby entrance may be integrated into the design of the FACADE or customized for individual storefronts and lobby entrances.
- d. Mechanical louvers necessary for venting purposes are not permitted in the required frame, but may be incorporated into any storefront or lobby entrance system.
- e. FACADES must differentiate the GROUND STORY of the building from the upper stories through horizontal ARTICULATION, a change in material, or a change in window size or pattern to create a distinct base to the building FACADE. The entire height of the GROUND STORY must be included in the FACADE base.
- f. For buildings with more than one FACADE, the design of the base must align horizontally at the corner.
- g. FACADES must provide surface relief from the average plane of the FACADE by at least four (4) inches, through

the USE of architectural elements such as bay windows, columns, CORNER BOARDS, CORNICES, door and window surrounds, moldings, PIERS, PILASTERS, recessed storefronts or lobby entrances, seat walls, sills, wall thickness, and recessed or projecting windows.

- h. The FACADE of any building greater than one hundred (100) feet in width must be designed as two (2) or more separate and distinct facades of differing architectural design so that the building appears to be multiple buildings. The facade designs must include a change in CORNICE, roof eave, or parapet design from one another.

## 12. Architectural Design Guidelines

- a. FACADES should be visually divided into a series of ARCHITECTURAL BAYS that are derived, in general, from the building's structural bay spacing.
- b. PIERS, PILASTERS, or other features defining each ARCHITECTURAL BAY should either extend all the way to the ground or terminate at any horizontal ARTICULATION defining the base of the building.
- c. ARCHITECTURAL BAYS should align, in general, with individual or groups of storefronts and lobby entrances.
- d. PIERS, PILASTERS, or other features defining each ARCHITECTURAL BAY should always project forward and be uninterrupted by any horizontal articulation, excluding any horizontal ARTICULATION USED to differentiate the base of the building.
- e. Vents, exhausts, and other utility features on building FACADES should be architecturally integrated into

Figure 4.2.11 (a) Storefront & Lobby Entrance Framing

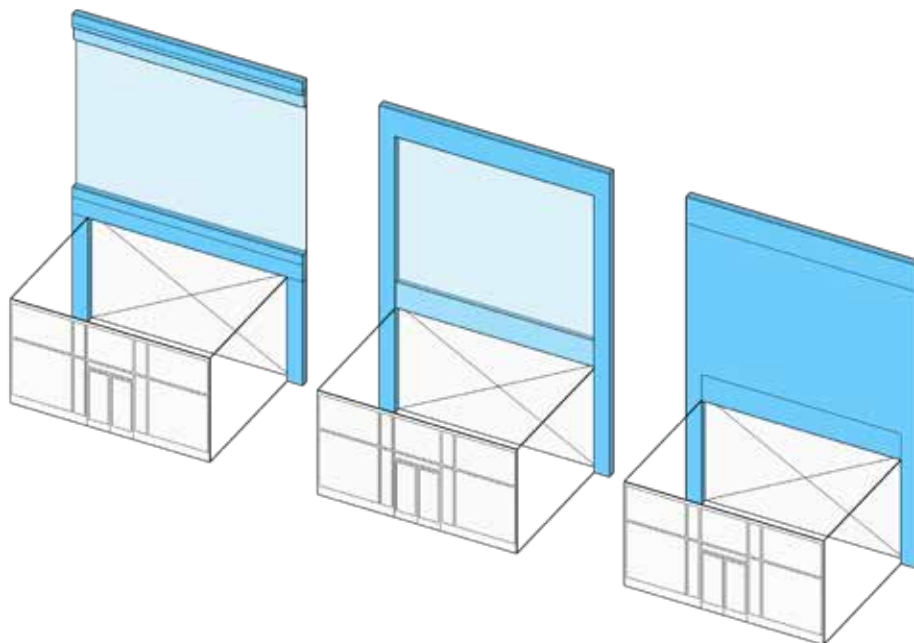

the design of the building and should be located to minimize adverse effects on pedestrian comfort along sidewalks and within OPEN SPACES.

- f. Buildings at TERMINATED VISTAS should be ARTICULATED with design features that function as focal points.
- g. FENESTRATION glazing should be inset from the plane of exterior wall surfaces.
- h. RIBBON WINDOWS should be avoided.
- i. Monotonous and repetitive storefront or lobby systems, awnings, canopies, SIGN types, colors, or designs should be avoided.
- j. Storefronts and lobby entrances should include awnings or canopies to provide weather protection for pedestrians and reduce glare for storefront display areas. Awnings should be open-ended and operable.
- k. Lobby entrances for UPPER STORY USES should be optimally located, well defined, clearly visible, and separate from the entrance for other GROUND STORY USES.
- l. Lobbies should be limited in both width and total area to preserve floor space and frontage for other GROUND STORY USES. Buildings should USE any combination of FACADE ARTICULATION, a double-height ceiling, a distinctive doorway, a change in wall material, a change in paving material within the FRONTAGE AREA, or some other architectural element(s) to make lobbies visual and materially distinctive.
- m. The selection of materials, FENESTRATION, and ornamentation should result in a consistent and harmonious composition that appears as a unified whole rather than a collection of unrelated parts, no

matter the style.

- n. The type and color of materials should be kept to a minimum, preferably three (3) or fewer.
- o. Two (2) or more wall materials should be combined only one above the other, except for bay windows.
- p. Wall materials appearing heavier in weight should be used below wall materials appearing lighter in weight (wood and metal above brick, and all three above stone)
- q. Horizontal or vertical board siding or shingles, regardless of material, should be avoided.
- r. Architectural details and finish materials for the base of a building should be constructed of architectural concrete or pre-cast cementitious panels, natural or cast stone, heavy gauge metal panels, glazed or unglazed architectural terracotta, or brick.
- s. Exterior Insulation and Finish Systems (EIFS) should be avoided.

**Figure 4.2.11 (b) Appearance of Two Buildings**





# 4. MID-RISE DISTRICTS

Mid-Rise 4 (MR4)

## 13. Use Provisions

- a. General
  - i. The USE of real property is subject to the provisions of Article 9: USE Provisions of this Ordinance. Where the provisions of this section conflict with those of Article 9, the provisions of Article 9 apply.
  - ii. USE categories are permitted as specified on Table 4.2.13. USE categories that are not identified on Table 4.2.13 are prohibited.
  - iii. All USEs must comply with any USE-specific standards applicable for each USE in §9.2 USE Definitions & Limitations.
  - iv. USEs permitted by Special Permit require additional DEVELOPMENT review in accordance with §15.2.1 Special Permits.
- b. USE Limitations
  - i. The USE of any GROUND STORY commercial space fronting a PEDESTRIAN STREET, excluding lobbies for UPPER STORY USES, is limited to the following PRINCIPAL USE categories:
    - a). Arts & Creative Enterprise
    - b). Food & Beverage Service
    - c). Retail Sales
    - d). Civic & Institutional
- c. Increases in Density
  - i. Existing STRUCTURES may not be altered to conflict with number of DWELLING UNITS permitted for each BUILDING TYPE.

**Table 4.2.13 Permitted Uses**

Use Category Specific Use	MR4
<b>Arts &amp; Creative Enterprise</b>	
Artisinal Production	P
Arts Exhibition	P
Arts Sales & Services	P
Co-working	P
Design Services	P
Shared Workspaces & Arts Education	P
<b>Cannabis Establishment</b>	
Cannabis Cultivation	P
Cannabis Retail Sales	SP
Cannabis Research & Development	P
Cannabis Testing Laboratory	P
<b>Civic &amp; Institutional</b>	
Community Center	P
Hospital	SP
Library	P
Minor Utility Facility	SP
Museum	P
Private Non-Profit Club or Lodge	SP
Public Service	P
Religious & Educational Uses Protected by M.G.L. 40A. Sec. 3	P

P - Permitted    SP - Special Permit Required    N - Not Permitted



**Table 4.2.13 Permitted Uses (continued)**

Use Category Specific Use	MR4
<b>Commercial Services</b>	
Animal Services (as noted below)	--
Commercial Kennel	SP
Pet Grooming	P
Pet Daycare & Training	SP
Veterinarian	SP
Assembly or Entertainment	SP
Banking & Financial Services (except as noted below)	P
Personal Credit	SP
Broadcast and/or Recording Studio	P
Building & Home Repair Services	SP
Business Support Services	P
Caterer/Wholesale Food Production	SP
Day Care Service (as noted below)	--
Adult Day Care Center	P
Child Day Care Center	P
Educational Services	P
Maintenance & Repair of Consumer Goods	P
Personal Services (except as noted below)	P
Body-Art Services	SP
Fitness Services	P
Funeral Services	SP
Health Care Services	SP
Formula Personal Services	SP
Recreation Services	SP
Vehicle Parking (except as follows)	--
Bike Share Parking	P
Car Share Parking (3 or fewer spaces)	P
Car Share Parking (4 or more spaces)	P
Commercial Parking	P
<b>Food and Beverage Service</b>	
Bar/Restaurant/Tavern	P
Bakery/Café/Coffee Shop	P
Formula Food & Beverage Service	SP

P - Permitted    SP - Special Permit Required    N - Not Permitted

**Table 4.2.13 Permitted Uses (continued)**

Use Category Specific Use	MR4
<b>Lodging</b>	
Bed & Breakfast	SP
Hotel or Hostel	SP
<b>Office</b>	
General Office	P
Research and Development or Laboratory	P
<b>Residential</b>	
Household Living	SP
Group Living (except as follows)	SP
Community or Group Residence	P
Dormitory, Fraternity or Sorority	SP
Homeless Shelter	SP
Nursing Home/Assisted Living Facility	SP
Rooming House	SP
<b>Retail Sales</b>	
Building/Home Supplies & Equipment	SP
Consumer Goods (except as follows)	P
Alcohol Sales	SP
Firearms Sales	N
Pet Store	SP
Formula Retail	SP
Fresh Food Market or Grocery Store	P
Farm/Vendor Market	P
<b>Urban Agriculture</b>	
Farming (as noted below)	--
Commercial Farming	P
Community Farming	P
Community Gardening	P

P - Permitted    SP - Special Permit Required    N - Not Permitted

# 4. MID-RISE DISTRICTS

Mid-Rise 4 (MR4)

**Table 4.2.13 Permitted Uses (continued)**

Use Category Specific Use	MR4
<b>Accessory Uses</b>	
<b>Home Occupations (as noted below)</b>	--
Home Office	P
<b>Urban Agriculture (as noted below)</b>	--
Apiculture	P
Aviculture	P
Commercial Farming	P
Residential Gardening	P
<b>Vehicle Parking, Accessory (except as follows)</b>	P
Home Business Vehicle Parking	N

P - Permitted SP - Special Permit Required N - Not Permitted

## 14. Development Standards

- a. General
  - i. DEVELOPMENT is subject to the provisions of Article 10: DEVELOPMENT STANDARDS of this Ordinance. Where the provisions of this section conflict with those of Article 10, the provisions of Article 10 apply.
- b. SIGNS
  - i. A SIGN, individual numerals or letters, or a nonelectrical nameplate identifying the property address is required for all real property as follows:
    - a). Each GROUND STORY non-residential USE must identify the STREET address either on the PRINCIPAL ENTRANCE door or above or beside the PRINCIPAL ENTRANCE of the USE.
    - b). All residential BUILDING TYPES must identify the STREET address either on the PRINCIPAL ENTRANCE door, above or beside the PRINCIPAL ENTRANCE, or on a mailbox.
  - ii. Address SIGNS must be made easily visible through the USE of colors or materials that contrast with the background material they are attached to and must be conspicuously located to provide visibility from the THOROUGHFARE that the BUILDING faces.
  - iii. Address SIGNS must be twelve (12) inches in height or less and may include the name of the occupant.

## 15. Parking & Mobility

- a. General
  - i. DEVELOPMENT is subject to the provisions of Article 11: Parking & Mobility of this Ordinance. Where the provisions of this section conflict with those of Article 11, the provisions of Article 11 apply.
  - ii. Vehicular parking must be provided as specified on Table 4.1 (d), except as follows:
    - a). Non-residential USES with five thousand (5,000) square feet or less of GROSS LEASABLE FLOOR AREA are exempt from any minimum requirements of Table 4.1. (d).
    - b). Any CHANGE IN USE within a non-residential STRUCTURE constructed before the effective date of this Ordinance, provided that the change is to a permitted USE, is exempt from any minimum requirements of Table 4.1 (d).
  - iii. There are no parking requirements for ACCESSORY USES.
  - iv. MOTOR VEHICLE PARKING spaces may be shared between USES on the same LOT and buildings on the same BLOCK in accordance with §11.3 SHARED PARKING.
- b. Type
  - i. MOTOR VEHICLE PARKING may be provided as SURFACE PARKING, above ground STRUCTURED PARKING, or underground STRUCTURED PARKING.
- c. Driveways
  - i. New driveways require a permit from the City Engineer.
  - ii. Driveways must be compliant with all City Ordinances and constructed in accordance with all standards established by relevant City Departments.
  - iii. Driveways are not permitted in the FRONTAGE AREA between a BUILDING and the FRONT LOT LINE.
  - iv. Driveways may be no wider than twenty four (24) feet in the FRONTAGE AREA of a LOT.
  - v. Driveways may provide ACCESS in whole or in part on or across an ABUTTING LOT(s), provided that an ACCESS EASEMENT exists between all PROPERTY OWNERS.
- d. Parking Design
  - i. The design of all parking is subject to §11.1 Bicycle Parking and §11.2 MOTOR VEHICLE PARKING of this Ordinance.
- e. Parking Location
  - i. Required vehicular parking, excluding any required handicapped parking, may be provided on a contiguous LOT under the same ownership as the LOT that the parking will serve as follows:
    - a). Pedestrian ACCESS to off-SITE vehicular parking must be via a paved sidewalk or walkway.
    - b). A lease, recorded covenant, or other comparable legal instrument guaranteeing long term USE of the SITE must be provided to the review board or BUILDING OFFICIAL and executed and filed with the Registry of Deeds.
  - ii. For real property located in more than one municipality, MOTOR VEHICLE PARKING need not be located within the City of Somerville.
- f. Unbundled Parking
  - i. MOTOR VEHICLE PARKING spaces must be rented or leased as an option rather than a requirement of the rental, lease, or purchase of a DWELLING UNIT or non-residential floor space.
  - ii. Bicycle parking must be provided at no cost or fee to customers, visitors, employees, tenants, and residents.
- g. Parking Relief
  - i. Relief from the parking standards of Table 4.2 (d) requires a Special Permit.
    - a). In addition to the review criteria for all Special Permits specified in §15.2.1.e. Review Criteria, the review board shall make findings considering the following in its discretion to approve or deny a special permit authorizing relief from the parking standards of Table 4.2 (d):
      - i). The supply and demand of on-STREET parking in the neighborhood, as determined through a parking study.
      - ii). MOBILITY MANAGEMENT programs and services provided by the APPLICANT to reduce the demand for parking.
      - iii). That parking provided in excess of any maximum permitted does not result in the increase in impervious LOT AREA.

## 16. Public Realm

- a. Sidewalks
  - i. When DEVELOPMENT OCCURS on any LOT ABUTTING a sidewalk that is less than twelve (12) feet in total width, the BUILDING must be set-back an additional distance to accommodate expansion of the ABUTTING sidewalk to a width of at least twelve (12) feet. The minimum and maximum front SETBACKS for each BUILDING TYPE are increased accordingly.
- b. Sidewalk CURB CUTS
  - i. A CURB CUT requires a permit from the City Engineer and must be compliant with all City Ordinances.
  - ii. Unless otherwise specified, the City Engineer may not permit more than one (1) CURB CUT per FRONT LOT LINE of a LOT.
  - iii. CURB CUTS are prohibited along all THOROUGHFARES designated as a PEDESTRIAN STREET.
  - iv. CURB CUTS must be located to minimize conflicts with pedestrians and bicyclists and must have a clear distance from fire hydrants, STREET TREES, utility

# 4. MID-RISE DISTRICTS

Mid-Rise 4 (MR4)

**Table 4.2.15 Vehicular Parking**

Use Category Specific Use	BICYCLE		MOTOR VEHICLE	
	Short-Term (min)	Long-Term (min)	Within a TRANSIT AREA <sup>1</sup> (max)	Outside of a TRANSIT AREA <sup>1</sup> (min)
<b>Arts &amp; Creative Enterprise</b>				
All Permitted Uses	1 / 10,000 sf	1 / 3,000 sf	1 / 800 sf	1 / 1,000 sf
<b>Cannabis Establishment</b>				
Cannabis Retail Sales	1 / 2,500 sf	1 / 10,000 sf	1 / 1,500 sf	1 / 750 sf
Cannabis Research & Development	1 / 20,000 sf	1 / 5,000 sf	1 / 1,000 sf	1 / 1,000 sf
Cannabis Testing Laboratory	1 / 20,000 sf	1 / 5,000 sf	1 / 1,000 sf	1 / 1,000 sf
<b>Civic &amp; Institutional</b>				
Community Center	1 / 10,000 sf	4 / 10,000 sf	1 / 1,800 sf	1 / 600 sf
Educational Facility	1.0 / classroom	4.0 / classroom	1.5 / classroom	3.0 / classroom
Hospital	10 per entrance	1 / 5,000 sf	1 / 200 sf	1 / 1,000 sf
Library	1 / 3,000 sf	1 / 5,000 sf	1 / 800 sf	1 / 500 sf
Minor Utility Facility	n/a	n/a	n/a	n/a
Museum	1 / 2,000 sf	1 / 10,000 sf	1 / 800 sf	1 / 500 sf
Private Non-Profit Club or Lodge	1 / 2,000 sf	1 / 10,000 sf	1 / 200 sf	1 / 1,000 sf
<b>Commercial Services</b>				
Animal Services (as noted below)	–	–	–	–
Commercial Kennel	1 / 2,500 sf	1 / 10,000 sf	1 / 500 sf	1 / 500 sf
Pet Grooming	1 / 2,500 sf	none	1 / 500 sf	1 / 500 sf
Pet Day Care or Training	1 / 2,500 sf	none	1 / 500 sf	1 / 500 sf
Veterinarian	1 / 2,500 sf	1 / 5,000 sf	1 / 500 sf	1 / 500 sf
Assembly or Entertainment	1 / 40 seats	1 / 10,000 sf	1 / 6 seats	1 / 6 seats
Banking & Financial Services (except as noted below)	1 / 2,000 sf	1 / 10,000 sf	1 / 450 sf	1 / 400 sf
Broadcast and/or Recording Studio	1 / 2,500 sf	1 / 10,000 sf	1 / 800 sf	1 / 600 sf
Building & Home Repair Services	1 / 2,500 sf	1 / 10,000 sf	1 / 1,000 sf	1 / 2,000 sf
Business Support Services	1 / 2,500 sf	1 / 10,000 sf	1 / 900 sf	1 / 600 sf
Caterer/Wholesale Food Production	1 / 2,500 sf	1 / 10,000 sf	1 / 800 sf	1 / 1,000 sf
Day Care Service	2	1 / 10,000 sf	1 / 900 sf	1 / 600 sf
Maintenance & Repair of Consumer Goods	1 / 2,500 sf	1 / 10,000 sf	1 / 750 sf	1 / 1,000 sf
Personal Services (except as noted below)	1 / 2,500 sf	1 / 10,000 sf	1 / 750 sf	1 / 1,000 sf
Health Care Services	1 / 2,000 sf	1 / 10,000 sf	1 / 500 sf	1 / 300 sf
Recreation Services	1 / 2,500 sf	1 / 10,000 sf	–	–

sf - Gross Leasable Square Footage

DU - Dwelling Unit RU - Rooming Unit

<sup>1</sup> See the Transit Area Map

**Table 4.2.15 Vehicular Parking (continued)**

Use Category Specific Use	BICYCLE		MOTOR VEHICLE	
	Short-Term (min)	Long-Term (min)	Within a TRANSIT AREA <sup>1</sup> (max)	Outside of a TRANSIT AREA <sup>1</sup> (min)
<b>Food and Beverage Service</b>				
All Permitted Uses	1 / 1,000 sf	1 / 5,000 sf	1 / 300 sf	1 / 500 sf
<b>Lodging</b>				
Bed & Breakfast	n/a	2.0	1 / DU + 1 / 4 guest rooms	1 / DU + 1 / 4 guest rooms
Hotel or Hostel	1 / 20 rooms	1 / 10 rooms	1 / 2 rooms	1 / 2 rooms
<b>Office</b>				
Co-Working	1 / 20,000 sf	1 / 3,000 sf	1 / 1,200 sf	1 / 800 sf
General Office	1 / 20,000 sf	1 / 3,000 sf	1 / 900 sf	1 / 650 sf
Research and Development or Laboratory	1 / 20,000 sf	1 / 5,000 sf	1 / 1,000 sf	1 / 1,000 sf
<b>Residential</b>				
Household Living	0.1 / DU	1.0 / DU	1.0 / DU	1.0 / DU
Group Living (except as follows)	0.05 / room	0.5 / room	--	--
Community or Group Residence	--	--	--	--
Dormitory, Fraternity or Sorority	0.1 / room	0.5 / room	.05 / bed	1.0 / 4 beds
Homeless Shelter	--	--	4.0	4.0
Nursing Home/Assisted Living Facility	--	--	1 / 6 beds	1 / 6 beds
Single Room Occupancy Housing	--	--	1 / 6 beds	1 / 4 beds
<b>Retail Sales</b>				
Building/Home Supplies & Equipment	1 / 2,500 sf	1 / 10,000 sf	1 / 1,000 sf	1 / 1,000 sf
Consumer Goods (except as follows)	1 / 2,500 sf	1 / 10,000 sf	1 / 1,500 sf	1 / 750 sf
Formula Retail	1 / 2,500 sf	1 / 10,000 sf	1 / 1,500 sf	1 / 750 sf
Fresh Food Market or Grocery Store	1 / 1,000 sf	1 / 10,000 sf	1 / 500 sf	1 / 1,500 sf
Farm/Vendor Market	n/a	n/a	n/a	1 / 1,500 sf

sf - Gross Leasable Square Footage      DU - Dwelling Unit      RU - Rooming Unit

<sup>1</sup> See the Transit Area Map

## 4. MID-RISE DISTRICTS

### Mid-Rise 4 (MR4)

poles, and other furnishings as deemed necessary by the City Engineer.

- a). CURB CUTS for commercial or high-volume driveways should be at least one-hundred (100) feet from an UNSIGNALIZED or SIGNALIZED intersection.
- b). CURB CUTS for residential driveways should be at least twenty (20) feet from an UNSIGNALIZED intersection and at least forty (40) feet from a SIGNALIZED intersection.
- v. The interior width of a CURB CUT (between curb stones) may be no wider than the driveway, vehicular entrance, or loading facility it serves.
- vi. A DRIVEWAY APRON may be installed only within the furnishing zone of a sidewalk and must be constructed in accordance with all standards established by relevant City Departments.
- vii. The grade, cross slope, and clear width of the walkway of a sidewalk must be maintained between the DRIVEWAY APRON and the ABUTTING driveway. The appearance of the walkway (ie. scoring pattern or paving material) must indicate that, although a vehicle may cross, the area traversed by a vehicle remains part of the sidewalk.

**Figure 4.2.16 Sidewalk Curb Cuts**

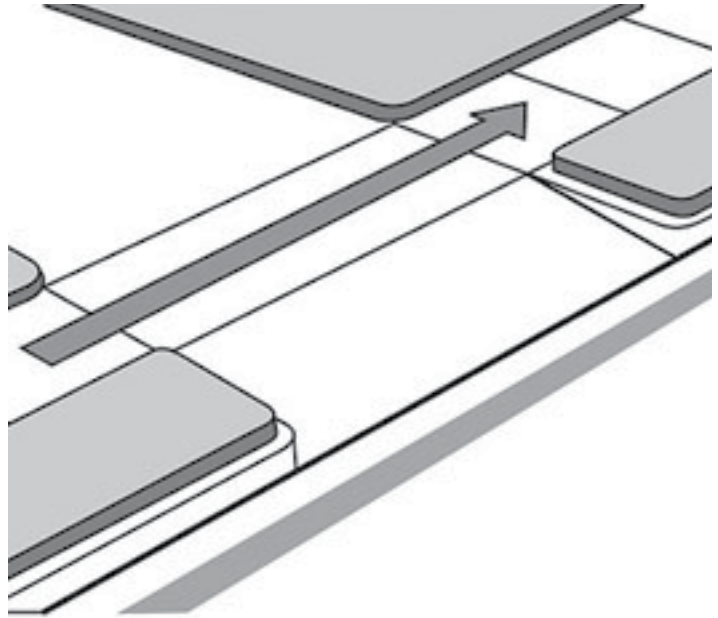



### 4.3 MID-RISE 5 (MR5)

#### 1. Description

The Mid-Rise 5 district is characterized by a variety of moderate to large FLOOR PLATE buildings up to five (5) stories in height with an UPPER STORY STEP-BACK after the fourth (4th) floor. Buildings are set close to the sidewalk to create a defined STREET wall that supports pedestrian activity and a sense of place. The district is primarily commercial, with GROUND STORY USES that address the needs of residents and employees from the immediate neighborhood, but can also provide goods and services to the larger Somerville community and visitors from the broader Boston metropolitan area.

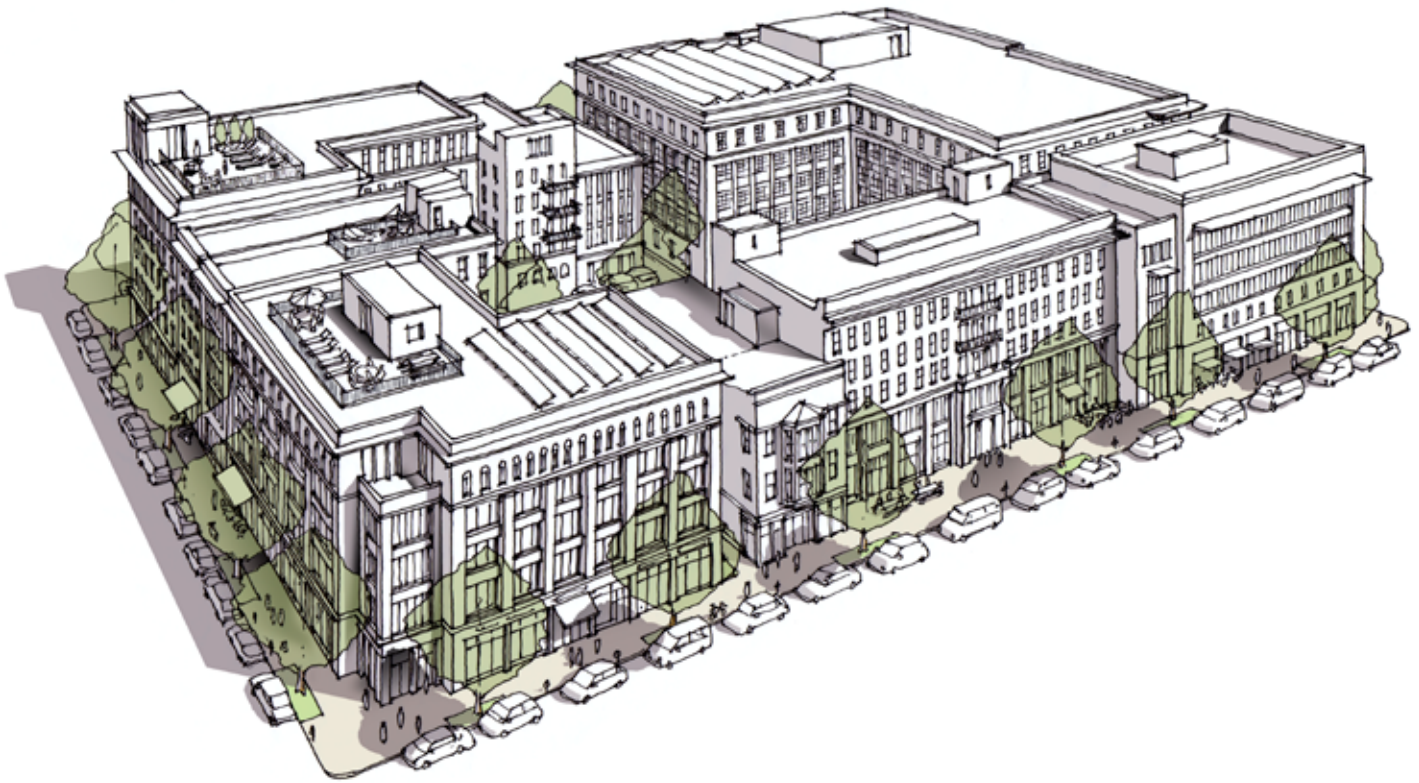

## 4. MID-RISE DISTRICTS

### Mid-Rise 5 (MR5)

#### 2. Intent

- a. To implement the objectives of the COMPREHENSIVE PLAN of the City of Somerville.
- b. To create, maintain, and enhance areas appropriate for moderate scale, multi-USE and mixed-USE buildings and neighborhood- and community-serving USES.

#### 3. Purpose

- a. To permit the DEVELOPMENT of multi-unit and mixed-USE buildings that do not exceed five (5) stories in height.
- b. To provide quality commercial spaces and permit small and medium scale, neighborhood- and community-serving commercial USES.
- c. To create DWELLING UNIT types, sizes, and BEDROOM counts ideal for larger households in apartment buildings.
- d. To create DWELLING UNIT types, sizes, and BEDROOM counts ideal for smaller households in general buildings.
- e. To permit increased residential density for buildings that are sustainable or that provide 100% AFFORDABLE HOUSING.
- f. To permit increased residential density for buildings that meet the definition of a NET ZERO BUILDING or 100% AFFORDABLE HOUSING.

#### 4. Applicability

- a. The section is applicable to all real property within the Mid-Rise 5 district as shown on the maps of the Official Zoning Atlas of the City of Somerville.

#### 5. Development Review

- a. DEVELOPMENT review is subject to the provisions of Article 15: Administration of this Ordinance.
- b. All DEVELOPMENT, excluding NORMAL MAINTENANCE, requires the submittal of a development review application to the BUILDING OFFICIAL and the issuance of a Certificate of Zoning Compliance prior to the issuance of a BUILDING Permit or Certificate of Occupancy.
- c. Proposed DEVELOPMENT may or may not necessitate the need for SUBDIVISION Plan Approval, Site Plan Approval, a Special Permit, or a Hardship Variance based on the nature of the proposal. In such cases, additional DEVELOPMENT review is required in accordance with Article 15: Administration.
  - i. The Planning Board is the decision making authority for all DEVELOPMENT that requires Site Plan Approval or a Special Permit.
  - ii. The Zoning Board of Appeals is the Review Board for all HARDSHIP Variances.
- d. Upon verification that no additional DEVELOPMENT review is necessary, or completion of the required DEVELOPMENT review, the BUILDING OFFICIAL shall issue a Zoning Compliance CERTIFICATE to certify compliance with the

provisions and procedures of this Ordinance.

#### 6. Building Types

- a. One (1) PRINCIPAL BUILDING TYPE is permitted on each LOT.
- b. The following BUILDING TYPES are permitted by Site Plan Approval in the Mid-Rise 5 district:
  - i. Apartment BUILDING
  - ii. General BUILDING
  - iii. Commercial BUILDING
- c. Apartment Buildings are prohibited on any LOT fronting a PEDESTRIAN STREET.
- d. ACCESSORY STRUCTURES are regulated according to Article 10: DEVELOPMENT Standards of this Ordinance.

## 4.3.7 Apartment Building

A moderate FLOOR PLATE, multi-STORY, PRINCIPAL BUILDING TYPE purpose built for OCCUPATION by residential USES on all stories.

The following images are examples of the apartment BUILDING TYPE and are intended only for illustrative purposes.





# 4. MID-RISE DISTRICTS

Mid-Rise 5 (MR5)

## 4.3.7. Apartment Building (continued)

a. Lot Standards

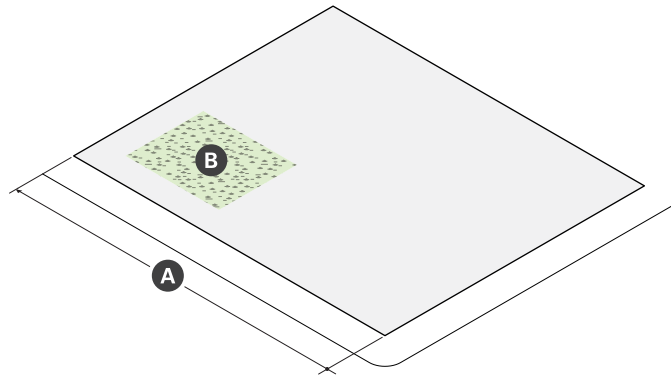

Lot Dimensions	
<b>A</b> LOT WIDTH (min)	30 ft

Lot Development	
LOT Coverage (max)	90%
GREEN SCORE	--
Minimum	0.20
Ideal	0.25
<b>B</b> OPEN SPACE (min)	15%

b. BUILDING Placement

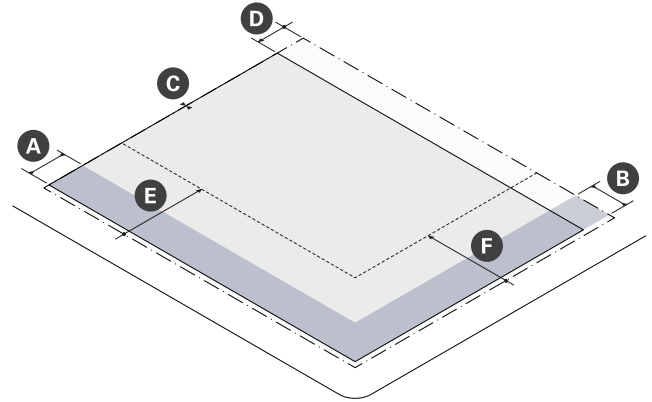

Building Setbacks		
<b>A</b> Primary Front SETBACK (min/max)	2 ft	12 ft
<b>B</b> Secondary Front SETBACK (min/max)	2 ft	12 ft
<b>C</b> Side SETBACK (min)	0 ft	
Side SETBACK ABUTTING NR or LHD (min)	10 ft	
<b>D</b> Rear SETBACK (min)	--	
ALLEY	0 ft	
No ALLEY	10 ft	
No ALLEY & ABUTTING NR or LHD	15 ft	

Parking Setbacks	
<b>E</b> Primary Front SETBACK (min)	--
SURFACE PARKING	30 ft
STRUCTURED PARKING	30 ft
<b>F</b> Secondary Front SETBACK (min)	--
SURFACE PARKING	10 ft
STRUCTURED PARKING	2 ft

## 4.3.7. Apartment Building (continued)

### c. Massing & Height

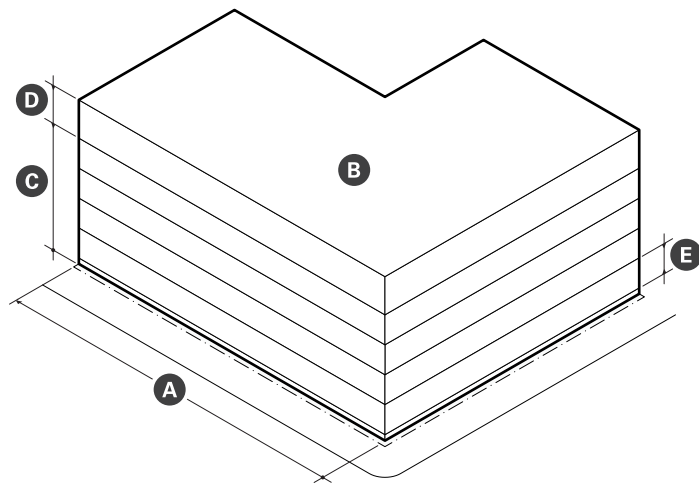

### d. Uses & Features

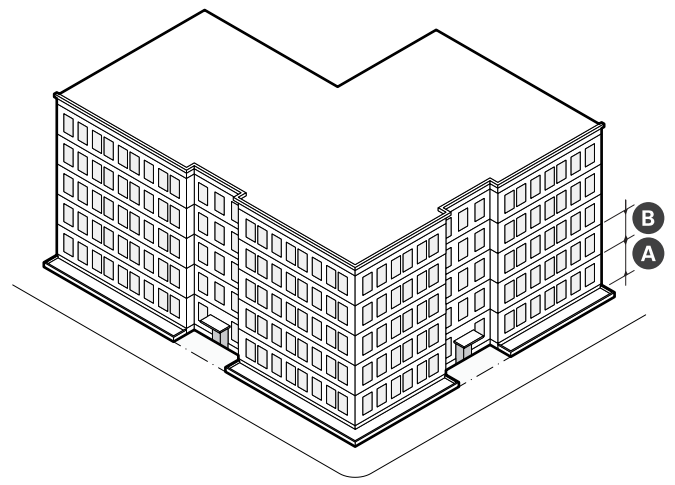

Main Massing	
<b>A</b> BUILDING WIDTH (max)	200 ft
FACADE Build Out, Primary Front (min)	--
Primary Front	80%
Secondary Front	65%
<b>B</b> FLOOR PLATE (max)	20,000 sf
GROUND STORY Elevation (min)	2 ft
<b>C</b> GROUND STORY Height	10 ft
<b>D</b> BUILDING Height, Stories (min/max)	3   5
<b>E</b> UPPER STORY STEP-BACK (min)	--
Primary/Secondary Front	10 ft
Side/Rear ABUTTING NR	30 ft
<b>F</b> BUILDING Height, Feet (max)	60 ft
Roof Type	Flat

Facade Composition	
<b>A</b> GROUND STORY FENESTRATION (min/max)	20% 50%
<b>B</b> UPPER STORY FENESTRATION (min/max)	20% 50%
BLANK WALL (max)	20 ft

Use & Occupancy	
GROSS FLOOR AREA per DU	--
LOT AREA < 5,500 sf	1,500
LOT AREA >= 5,500 sf	1,125
NET ZERO BUILDING	850
100% AFFORDABLE HOUSING	850
OUTDOOR AMENITY SPACE (min)	1/DU

# 4. MID-RISE DISTRICTS

Mid-Rise 5 (MR5)

## 4.3.7. Apartment Building (continued)

- e. DEVELOPMENT Benefits
  - i. DEVELOPMENT is subject to the provisions of Article 12: DEVELOPMENT Benefits of this Ordinance. Where the provisions of this section conflict with those of Article 12, the provisions of Article 12 apply.
  - ii. DEVELOPMENT of a general building must provide AFFORDABLE DWELLING UNITS as specified on Table 4.3.7.
- f. Design Guidelines
  - i. GROUND STORY DWELLING UNITS should be elevated above the grade of any adjacent sidewalk so that the window sills of the DWELLING UNIT are at or above the eye-level of passing pedestrians. This elevation change maintains privacy for occupants while also encouraging open blinds or curtains to allow natural daylight into the unit.
  - ii. FENESTRATION patterns and window configurations should break the direct line of sight between neighboring properties to every extent practicable. Translucent glass on the bottom half of windows or strategically placed landscape elements should be utilized if it is not practical to off-set windows in such a way as to minimize privacy impacts.
  - iii. Outdoor AMENITY SPACES that are elevated, such as roof DECKS, fully projecting balconies, and UPPER STORY rear porches should, provide sight-obscuring visual screening at the sides to increase privacy, security, and to limit views of ABUTTING properties from elevated vantage points.

**Table 4.3.7 Required ADUs**

Total DWELLING UNITS	Required ADUs
0 to 5 units	None
6 units	1 unit OR fractional buyout for 0.4 units
7 units	1 unit OR fractional buyout for 0.6 units
8 to 17 units	17.5% of units
18 or more units	20% of units



## 4.3.8 General Building

A moderate FLOOR PLATE, multi-STORY PRINCIPAL BUILDING TYPE with GROUND STORY commercial space and no limitations on the occupancy of UPPER STORIES for permitted USES. The UPPER STORIES of a general BUILDING are typically residential, but a wide variety exists. As the number of stories increases, it becomes more likely for the UPPER STORIES of a general BUILDING to host commercial USES as well as residential.

The following images are examples of the general BUILDING TYPE and are intended only for illustrative purposes.



# 4. MID-RISE DISTRICTS

Mid-Rise 5 (MR5)

## 4.3.8. General Building (continued)

a. LOT Standards

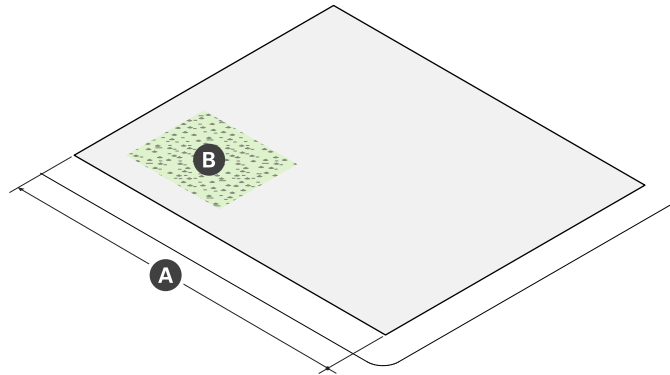

Lot Dimensions	
<b>A</b> LOT WIDTH (min)	30 ft

Lot Development	
LOT Coverage (max)	90%
GREEN SCORE	--
Minimum	0.20
Ideal	0.25
<b>B</b> OPEN SPACE (min)	15%

b. BUILDING Placement

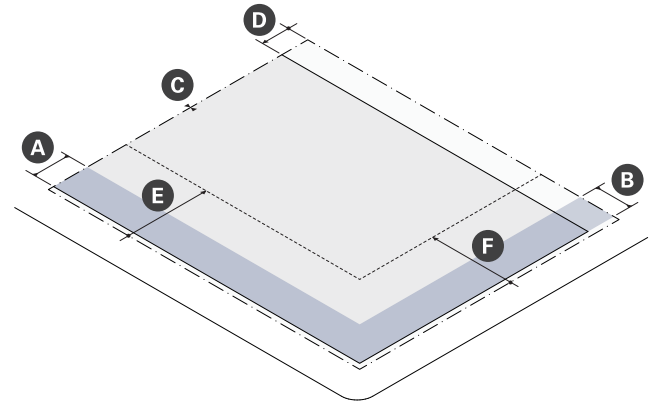

Building Setbacks		
<b>A</b> Primary Front SETBACK (min/max)	2 ft	15 ft
<b>B</b> Secondary Front SETBACK (min/max)	2 ft	15 ft
<b>C</b> Side SETBACK (min)	0 ft	
Side SETBACK ABUTTING NR or LHD (min)	10 ft	
<b>D</b> Rear SETBACK (min)	--	
ALLEY	0 ft	
No ALLEY	10 ft	
No ALLEY & ABUTTING NR or LHD	15 ft	

Parking Setbacks	
<b>E</b> Primary Front SETBACK (min)	--
SURFACE PARKING	30 ft
STRUCTURED PARKING	30 ft
<b>F</b> Secondary Front SETBACK (min)	--
SURFACE PARKING	10 ft
STRUCTURED PARKING	2 ft

## 4.3.8. General Building (continued)

c. Massing & Height

d. Uses & Features

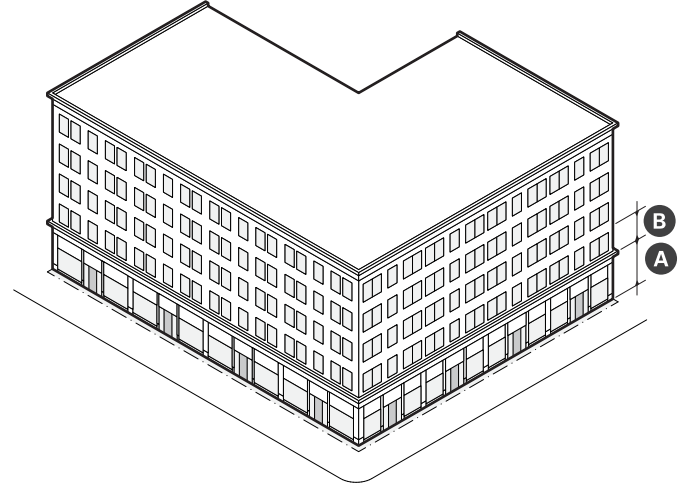
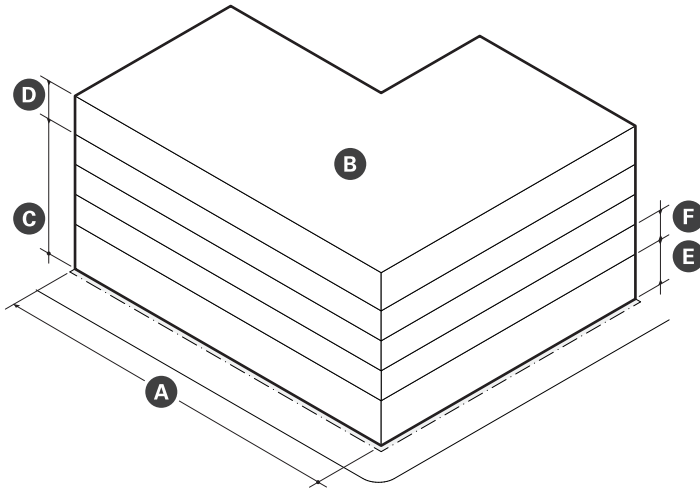

Main Massing	
<b>A</b> BUILDING WIDTH (max)	200 ft
FACADE Build Out (min)	--
Primary Front	80%
Secondary Front	65%
<b>B</b> FLOOR PLATE (max)	20,000 sf
<b>C</b> GROUND STORY Height	14 ft
<b>D</b> UPPER STORY Height	10 ft
<b>E</b> Number of Stories (min/max)	3   5
<b>F</b> UPPER STORY STEP-BACK (min)	--
Primary/Secondary Front	10 ft
Side/Rear ABUTTING NR	30 ft
<b>G</b> BUILDING Height, Feet (max)	65 ft
Roof Type	Flat

Facade Composition	
<b>A</b> GROUND STORY FENESTRATION (min)	70%
<b>B</b> UPPER STORY FENESTRATION (min/max)	20%   50%
BLANK WALL (max)	20 ft

Use & Occupancy	
GROUND STORY Entrance Spacing (max)	30 ft
Commercial Space Depth (min)	30 ft
GROSS FLOOR AREA per DU	--
LOT AREA < 5,500 sf	1,500
LOT AREA >= 5,500 sf	1,125
NET ZERO BUILDING	850
100% AFFORDABLE HOUSING	850
Outdoor AMENITY SPACE (min)	1/DU

# 4. MID-RISE DISTRICTS

Mid-Rise 5 (MR5)

## 4.3.8. General Building (continued)

- e. DEVELOPMENT Benefits
  - i. DEVELOPMENT is subject to the provisions of Article 12: DEVELOPMENT Benefits of this Ordinance. Where the provisions of this section conflict with those of Article 12, the provisions of Article 12 apply.
  - ii. DEVELOPMENT of a general building must provide AFFORDABLE DWELLING UNITS as specified on Table 4.3.8 (a).
  - iii. DEVELOPMENT of a general building must provide linkage payments as specified on Table 4.3.8 (b).
- f. Design Guidelines
  - i. FENESTRATION patterns and window configurations should break the direct line of sight between neighboring properties to every extent practicable. Translucent glass on the bottom half of windows or strategically placed landscape elements should be utilized if it is not practical to off-set windows in such a way as to minimize privacy impacts.
  - ii. Outdoor AMENITY SPACES that are elevated, such as roof DECKS, fully projecting balconies, and UPPER STORY rear porches should, provide sight-obscuring visual screening at the sides to increase privacy, security, and to limit views of ABUTTING properties from elevated vantage points.

**Table 4.3.8 (a) Required ADUs**

Total DWELLING UNITS	Required ADUs
0 to 5 units	None
6 units	1 unit OR fractional buyout for 0.4 units
7 units	1 unit OR fractional buyout for 0.6 units
8 to 17 units	17.5% of units
18 or more units	20% of units

**Table 4.3.8 (b) Linkage**

Commercial GROSS FLOOR AREA	Affordable Housing Linkage	Employment Linkage
30,000 sf or less	None	None
Over 30,000 sf	\$10/sf	\$2.46/sf



## 4.3.9 Commercial Building

A moderate FLOOR PLATE, multi-STORY, PRINCIPAL BUILDING TYPE purpose built for occupation by commercial uses on all stories. GROUND STORY commercial space is primarily occupied by commercial service, food & beverage service, or retail sales PRINCIPAL USES. Floor space on upper stories may be occupied by retail uses that do not rely on the visibility of a storefront at sidewalk level.

The following images are examples of the commercial BUILDING TYPE and are intended only for illustrative purposes.



# 4. MID-RISE DISTRICTS

Mid-Rise 5 (MR5)

## 4.3.9. Commercial Building (continued)

a. LOT Standards

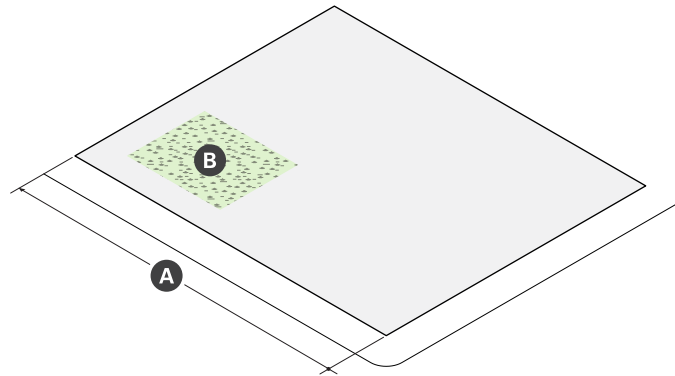

Lot Dimensions	
<b>A</b> LOT WIDTH (min)	30 ft

Lot Development	
LOT Coverage (max)	90%
GREEN SCORE	--
Minimum	0.20
Ideal	0.25
<b>B</b> OPEN SPACE (min)	15%

b. BUILDING Placement

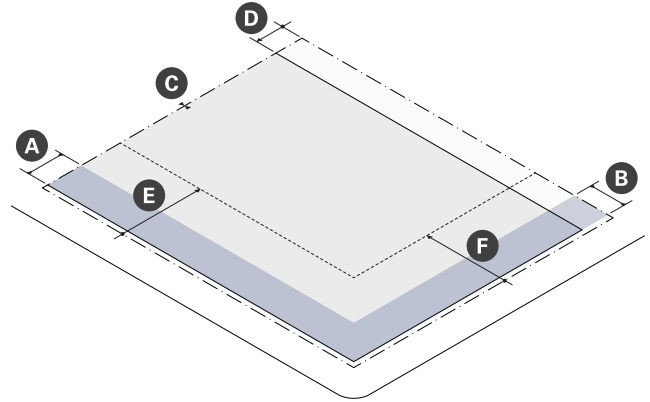

Building Setbacks		
<b>A</b> Primary Front SETBACK (min/max)	2 ft	15 ft
<b>B</b> Secondary Front SETBACK (min/max)	2 ft	15 ft
<b>C</b> Side SETBACK (min)	0 ft	
Side SETBACK ABUTTING NR or LHD (min)	10 ft	
<b>D</b> Rear SETBACK (min)	--	
ALLEY	0 ft	
No ALLEY	10 ft	
No ALLEY & ABUTTING NR or LHD	15 ft	

Parking Setbacks	
<b>E</b> Primary Front SETBACK (min)	--
SURFACE PARKING	30 ft
STRUCTURED PARKING	30 ft
<b>F</b> Secondary Front SETBACK (min)	--
SURFACE PARKING	10 ft
STRUCTURED PARKING	2 ft



## 4.3.9. Commercial Building (continued)

### c. Massing & Height

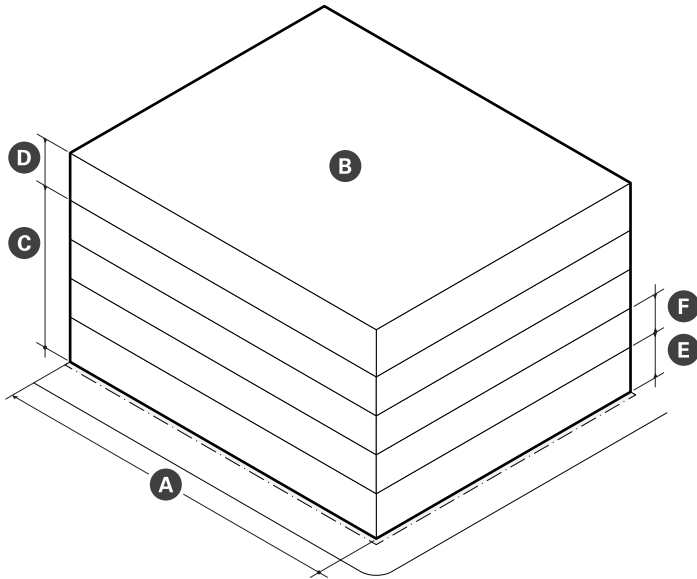

### d. Uses & Features

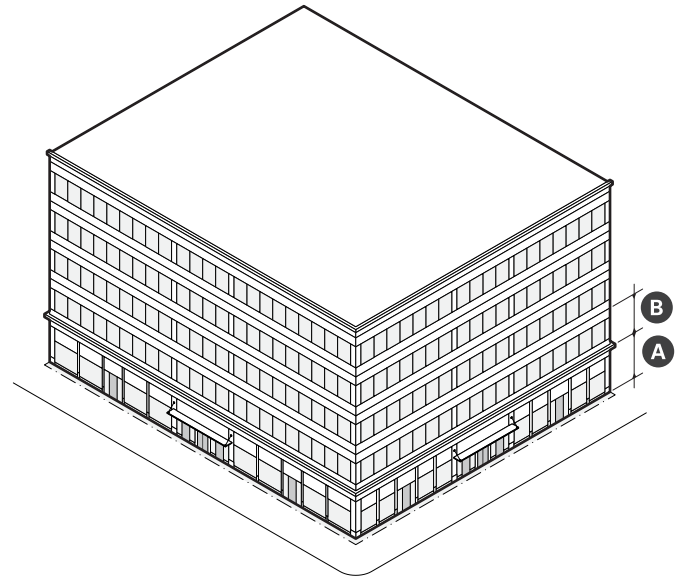

Main Massing	
<b>A</b> BUILDING WIDTH (max)	200 ft
FACADE Build Out (min)	–
Primary Front	80%
Secondary Front	65%
<b>B</b> FLOOR PLATE (max)	20,000 sf
<b>C</b> GROUND STORY Height	14 ft
<b>D</b> UPPER STORY Height	10 ft
<b>E</b> Number of Stories (min/max)	3   5
<b>F</b> UPPER STORY STEP-BACK (min)	–
Primary/Secondary Front	10 ft
Side/Rear ABUTTING NR	30 ft
<b>G</b> BUILDING Height, Feet (max)	75 ft
Roof Type	Flat

Facade Composition	
<b>A</b> GROUND STORY FENESTRATION (min)	70%
<b>B</b> UPPER STORY FENESTRATION (min/max)	20% 70%
BLANK WALL (max)	20 ft

Use & Occupancy	
GROUND STORY Entrance Spacing (max)	30 ft
Commercial Space Depth (min)	30 ft

## 4. MID-RISE DISTRICTS

Mid-Rise 5 (MR5)

### 4.3.9. Commercial Building (continued)

- e. DEVELOPMENT Benefits
  - i. DEVELOPMENT is subject to the provisions of Article 12: DEVELOPMENT Benefits of this Ordinance. Where the provisions of this section conflict with those of Article 12, the provisions of Article 12 apply.
  - ii. DEVELOPMENT of a general building must provide linkage payments as specified on Table 4.3.9.

**Table 4.3.9 Linkage**

<b>Commercial GROSS FLOOR AREA</b>	<b>Affordable Housing Linkage</b>	<b>Employment Linkage</b>
<b>30,000 sf or less</b>	<b>None</b>	<b>None</b>
<b>Over 30,000 sf</b>	<b>\$10/sf</b>	<b>\$2.46/sf</b>

## 10. Building Components

- a. BUILDING COMPONENTS are ACCESSORY elements attached to the MAIN MASSING of a PRINCIPAL BUILDING.
- b. BUILDING COMPONENTS are permitted by Site Plan Approval as specified on Table 4.3.10.
  - i. At least one (1) storefront is required for each GROUND STORY commercial space.
- c. BUILDING COMPONENTS that are not identified on Table 4.2.10 are prohibited.
- d. Unless otherwise specified, BUILDING COMPONENTS may attach to other BUILDING COMPONENTS to create assemblies of components.

**Table 4.3.10 Building Components**

	Apartment Building	General Building	Commercial Building
Awning	N	P	P
Entry Canopy	P	P	P
Lobby Entrance	P	P	P
Storefront	N	P	P
Stoop	P	N	N
Bay Window	P	P	P
Balcony	P	P	N
Arcade	N	N	N

P - Permitted    SP - Special Permit Required    N - Not Permitted

# 4. MID-RISE DISTRICTS

## Mid-Rise 5 (MR5)

### e. Awning

- i. An awning is a wall mounted frame covered with fabric or other material that provides shade and weather protection over a storefront or BUILDING entrance.

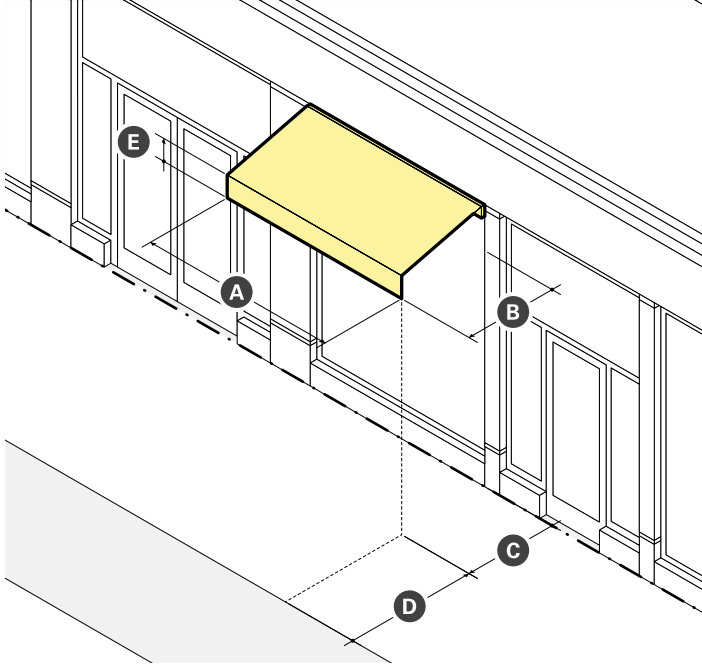

Dimensions	
<b>A</b> Width (min)	See ii Standards
<b>B</b> Projection (min)	3 ft
<b>C</b> CLEARANCE (min)	8 ft
Front SETBACK ENCROACHMENT (max)	100%
<b>D</b> SETBACK from Curb (min)	2 ft
<b>E</b> Valance Height (max)	12 in

- ii. Standards
  - a). Awnings must be securely attached to and supported by the BUILDING and must fit the windows or doors the awning is attached to.
  - b). An awning must be made of durable, weather-resistant material that is water repellent.
  - c). Internally illuminated or back-lit awnings are prohibited.
  - d). An awning that projects over the sidewalk of a public THOROUGHFARE requires compliance with all City Ordinances.

### f. Entry Canopy

- i. An entry canopy is a wall-mounted STRUCTURE that provides shade and weather protection over a storefront or BUILDING entrance.

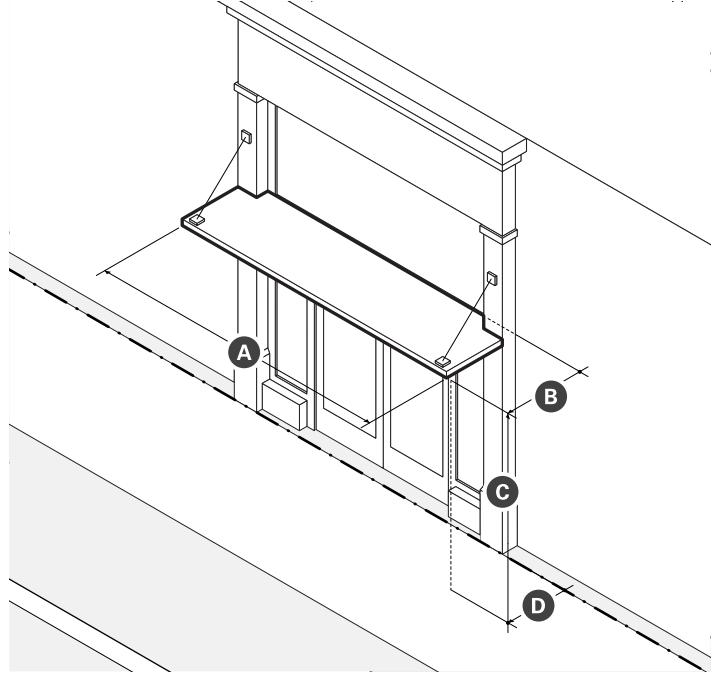

Dimensions	
<b>A</b> Width (min)	See ii Standards
<b>B</b> Projection (min)	3 ft
<b>C</b> CLEARANCE (min)	8 ft
<b>D</b> Front SETBACK ENCROACHMENT (max)	100%
SETBACK from Curb (min)	2 ft

- ii. Standards
  - a). Entry canopies must be visually supported by brackets, cables, or rods.
  - b). The width of an entry canopy must be equal to or greater than the width of the doorway surround or exterior casing it is mounted over.

## g. Lobby Entrance

- i. A lobby entrance is a non-load bearing assembly of entry doors and windows providing ACCESS and light to the lobby of a BUILDING.

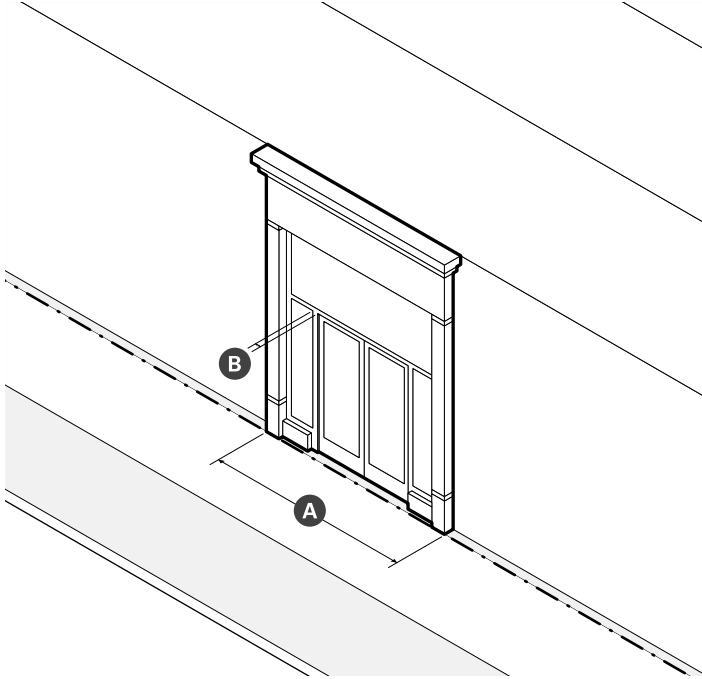

Dimensions		
<b>A</b> Width (min/max)	15 ft	30 ft
<b>B</b> Height (min)	80% of GROUND STORY Height	
Recessed Entrance Width (max)	15 ft	
Recessed Entrance Depth (max)	5 ft	

- ii. Standards
  - a). When a lobby entrance is set back from the FRONT LOT LINE, the FRONTAGE AREA must be paved.

## h. Storefront

- i. A storefront is a non-load bearing assembly of commercial entry doors and windows providing ACCESS and light to a commercial space and a place to display goods, services, and SIGNS.

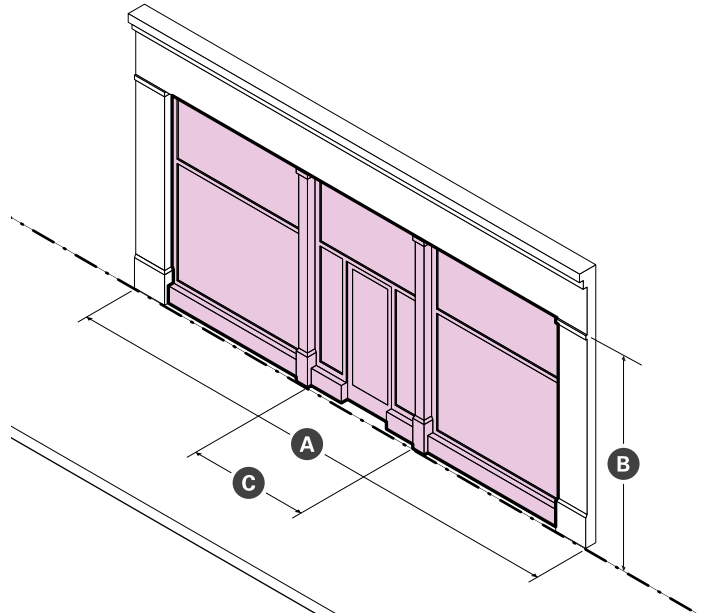

Dimensions		
<b>A</b> Width (min/max)	15 ft	30 ft
<b>B</b> Height (min)	80% of GROUND STORY Height	
Display Window Height (min)	8 ft	
Recessed Entrance Width (max)	15 ft	
Recessed Entrance Depth (max)	5 ft	

- ii. Standards
  - a). An unobstructed view of the interior space or a lighted and maintained merchandise display(s) must be provided for a depth of at least four (4) feet behind storefront display windows.
  - b). When storefronts are set back from the FRONT LOT LINE, the FRONTAGE AREA must be paved.
  - c). When present, awnings and canopies must be mounted between columns, PILASTERS, OR PIERS; above doorways and display windows; and below the SIGN BAND.
  - d). Exterior security grilles, gates, and roll-down security doors and windows are prohibited.

# 4. MID-RISE DISTRICTS

Mid-Rise 5 (MR5)

## i. Stoop

- i. A stoop is a set of stairs with a landing leading to the entrance of a BUILDING.

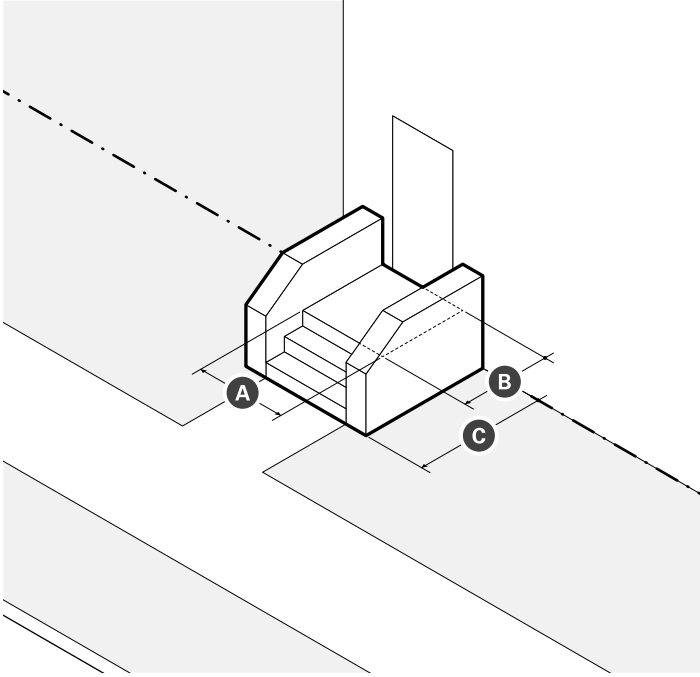

Dimensions	
<b>A</b> Landing Width (min)	4 ft
<b>B</b> Landing Depth (min)	4 ft
<b>C</b> Front SETBACK ENCROACHMENT (max)	100%

- ii. Standards
  - a). Paving, excluding driveways, must match the ABUTTING sidewalk unless paved with pervious, porous, or permeable materials.
  - b). Stairs may be recessed into the BUILDING FACADE when the BUILDING is set back four (4) feet or less.
  - c). Stairs are not permitted to ENCROACH onto any ABUTTING sidewalk.
  - d). Stairs may be built perpendicular or parallel to the BUILDING FACADE, but must lead directly to ground level or an ABUTTING sidewalk.

## j. Bay Window

- i. A bay window is an assembly of windows projecting from a building to provide additional HABITABLE space, increased light, multi-directional views, and ARTICULATION to an exterior wall.

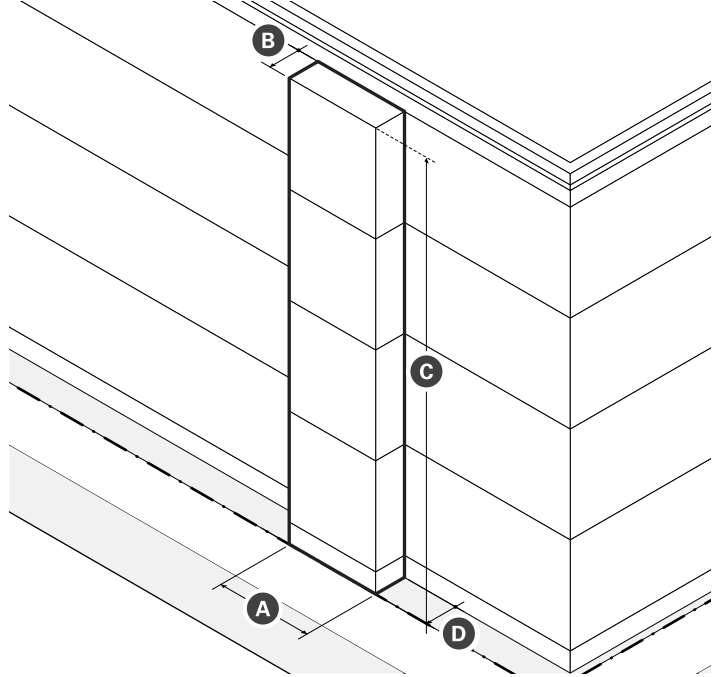

Dimensions	
<b>A</b> Width (max)	16 ft
<b>B</b> Projection (max)	3 ft
<b>C</b> Height (max)	Height of BUILDING in Stories
<b>D</b> Front SETBACK ENCROACHMENT (max)	3 ft
FENESTRATION (min)	60%

- ii. Standards
  - a). Bay windows, including box and bow windows, must include at least three (3) windows.
  - b). The cumulative width of multiple bays may equal up to fifty percent (50%) of the width of the exterior wall from which the bays project.
  - c). Bays projecting over the sidewalk of a public THOROUGHFARE must have at least two (2) stories of CLEARANCE and be compliant with all City Ordinances.



## k. Balcony

- i. A balcony is a platform with a railing that provides outdoor AMENITY SPACE.

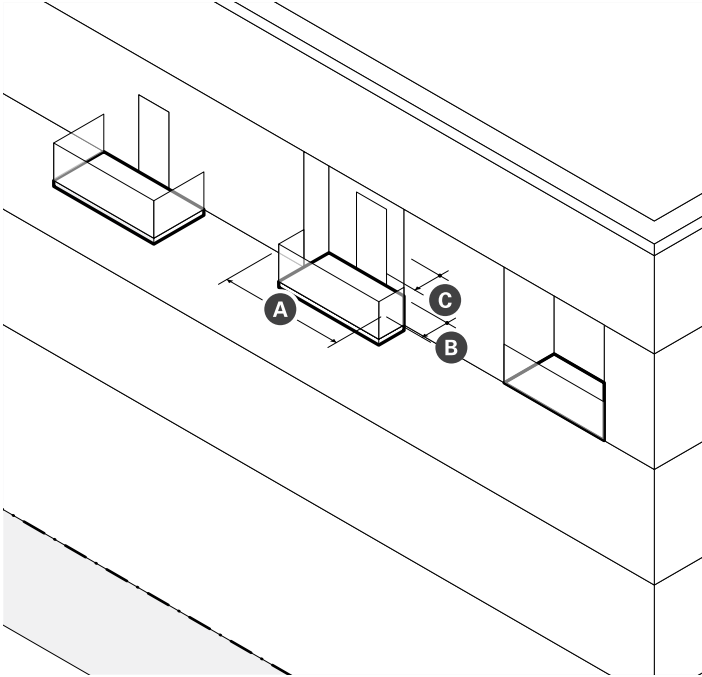

Dimensions	
<b>A</b> Width (min)	5 ft
<b>B</b> Depth (max)	5 ft
<b>D</b> Area (min)	50 ft
CLEARANCE (min)	10 ft
Permitted Front SETBACK ENCROACHMENT (max)	6 ft

- ii. Standards
  - a). Balconies may be recessed, projecting, a combination of the two, or terraced as part of the roof of a portico, porch, or bay.
  - b). A balcony that projects over the sidewalk of a public THOROUGHFARE requires compliance with all City Ordinances.
  - c). The guard rail of any balcony oriented toward a FRONT LOT LINE must permit visual supervision of the PUBLIC REALM through the posts and rails.
  - d). The guard rail of any balcony oriented toward a side OF REAR LOT LINE ABUTTING the NR district must include sight-obscuring visual screening so that it is at least fifty percent (50%) opaque.

## l. Arcade

- i. An arcade is a pedestrian walkway covered by the upper floors of a BUILDING. The GROUND STORY FACADE is SETBACK and upper floors are supported by a colonnade or supports.

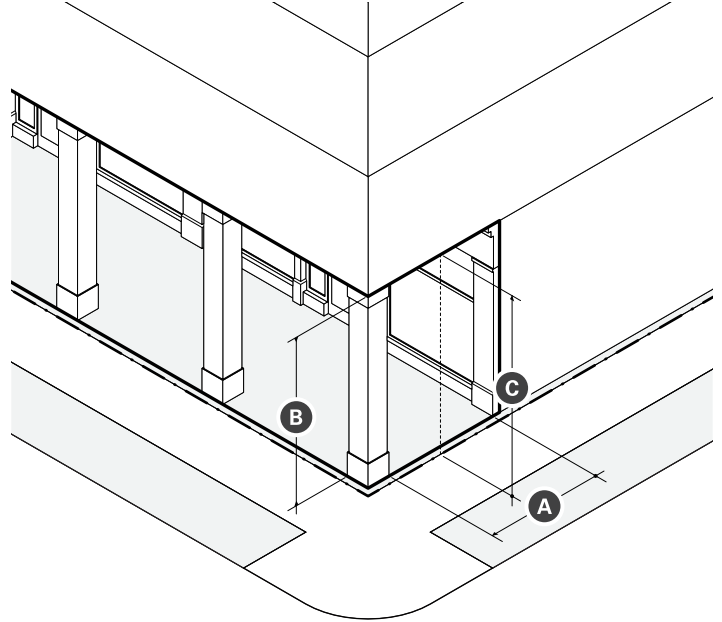

Dimensions		
<b>A</b> Depth (min/max)	10 ft	15 ft
<b>B</b> Height (max)	1 STORY	
<b>C</b> CLEARANCE (min/max)	14 ft	24 ft

- ii. Standards
  - a). Arcades must extend the entire width of a BUILDING and must have a consistent depth.
  - b). Support columns or PIERS may be spaced no farther apart than they are tall.
  - c). Arcades are considered part of the BUILDING for the purpose of measuring FACADE build out.
  - d). Arcades may be combined only with storefront and lobby entrance frontages.
  - e). The finished ceiling of an arcade interior may be arched or flat, but must have a greater CLEARANCE than the openings between columns OR PIERS.

## 4. MID-RISE DISTRICTS

### Mid-Rise 5 (MR5)

#### 11. Facade Design

- a. FACADES must provide solid material framing each storefront and lobby entrance as follows:
  - i. PILASTERS or columns supporting a horizontal lintel and CORNICE;
  - ii. a spandrel positioned between PILASTERS or columns that extend from upper stories of the building to the ground; or
  - iii. flat wall above and to either side of a void or punched opening.
- b. Storefronts and lobby entrances must be set within the resulting frame provided for each by the FACADE.
- c. Materials framing each storefront or lobby entrance may be integrated into the design of the FACADE or customized for individual storefronts and lobby entrances.
- d. Mechanical louvers necessary for venting purposes are not permitted in the required frame, but may be incorporated into any storefront or lobby entrance system.
- e. FACADES must differentiate the GROUND STORY of the building from the upper stories through horizontal ARTICULATION, a change in material, or a change in window size or pattern to create a distinct base to the building FACADE. The entire height of the GROUND STORY must be included in the FACADE base.
- f. Buildings of five (5) or more stories should include, at least, the entire height of the first two (2) stories in the required base. The design of the base may not shift up or down across the width of the FACADE.

- g. For buildings with more than one FACADE, the design of the base must align horizontally at the corner.
- h. FACADES must provide surface relief from the average plane of the FACADE by at least four (4) inches, through the USE of architectural elements such as bay windows, columns, CORNER BOARDS, CORNICES, door and window surrounds, moldings, PIERS, PILASTERS, recessed storefronts or lobby entrances, seat walls, sills, wall thickness, and recessed or projecting windows.
- i. The FACADE of any building greater than one hundred (100) feet in width must be designed as two (2) or more separate and distinct facades of differing architectural design so that the building appears to be multiple buildings. The facade designs must include a change in CORNICE, roof eave, or parapet design from one another.

#### 12. Architectural Design Guidelines

- a. FACADES should be visually divided into a series of ARCHITECTURAL BAYS that are derived, in general, from the building's structural bay spacing.
- b. PIERS, PILASTERS, or other features defining each ARCHITECTURAL BAY should either extend all the way to the ground or terminate at any horizontal ARTICULATION defining the base of the building.
- c. ARCHITECTURAL BAYS should align, in general, with individual or groups of storefronts and lobby entrances.
- d. PIERS, PILASTERS, or other features defining each ARCHITECTURAL BAY should always project forward and be uninterrupted by any horizontal articulation, excluding

Figure 4.3.11 (a) Storefront & Lobby Entrance Framing

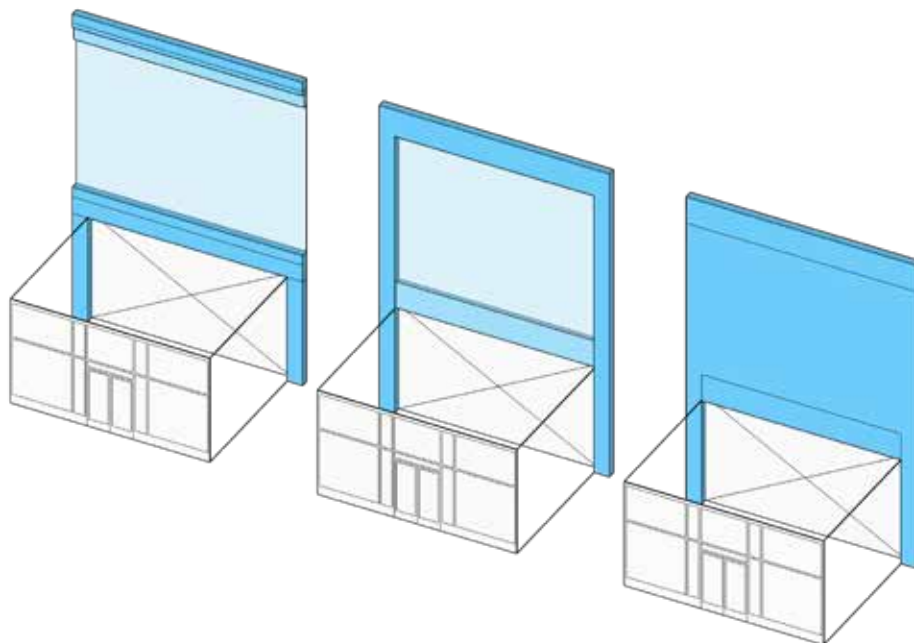

- any horizontal ARTICULATION USED to differentiate the base of the building.
- e. The FACADE of buildings with five (5) or more stories should be visually divided into, at least, a horizontal tripartite division (a base, middle, and top). The horizontal divisions may not shift up or down across the width of the FACADE.
  - f. Vents, exhausts, and other utility features on building FACADES should be architecturally integrated into the design of the building and should be located to minimize adverse effects on pedestrian comfort along sidewalks and within OPEN SPACES.
  - g. Buildings at TERMINATED VISTAS should be ARTICULATED with design features that function as focal points.
  - h. FENESTRATION glazing should be inset from the plane of exterior wall surfaces.
  - i. RIBBON WINDOWS should be avoided.
  - j. Monotonous and repetitive storefront or lobby systems, awnings, canopies, SIGN types, colors, or designs should be avoided.
  - k. Storefronts and lobby entrances should include awnings or canopies to provide weather protection for pedestrians and reduce glare for storefront display areas. Awnings should be open-ended and operable.
  - l. Lobby entrances for UPPER STORY USES should be optimally located, well defined, clearly visible, and separate from the entrance for other GROUND STORY USES.
  - m. Lobbies should be limited in both width and total area to preserve floor space and frontage for other GROUND STORY USES. Buildings should USE any combination of FACADE ARTICULATION, a double-height ceiling, a distinctive doorway, a change in wall material, a change in paving material within the FRONTAGE AREA, or some other architectural element(s) to make lobbies visual and materially distinctive.
  - n. The selection of materials, FENESTRATION, and ornamentation should result in a consistent and harmonious composition that appears as a unified whole rather than a collection of unrelated parts, no matter the style.
  - o. The type and color of materials should be kept to a minimum, preferably three (3) or fewer.
  - p. Two (2) or more wall materials should be combined only one above the other, except for bay windows.
  - q. Wall materials appearing heavier in weight should be used below wall materials appearing lighter in weight (wood and metal above brick, and all three above stone)
  - r. Horizontal or vertical board siding or shingles, regardless of material, should be avoided.
  - s. Architectural details and finish materials for the base of a building should be constructed of architectural concrete or pre-cast cementitious panels, natural or cast stone, heavy gauge metal panels, glazed or unglazed architectural terracotta, or brick.
  - t. Exterior Insulation and Finish Systems (EIFS) should be avoided.

**Figure 4.3.11 (b) Appearance of Two Buildings**



# 4. MID-RISE DISTRICTS

Mid-Rise 5 (MR5)

## 13. Use Provisions

- a. General
  - i. The USE of real property is subject to the provisions of Article 9: USE Provisions of this Ordinance. Where the provisions of this section conflict with those of Article 9, the provisions of Article 9 apply.
  - ii. USE categories are permitted as specified on Table 4.1 (c). USE categories not identified on Table 4.3.13 are prohibited.
  - iii. All USES must comply with any USE-specific standards applicable for each USE in §9.2 USE Definitions & Limitations.
  - iv. USES permitted by Special Permit require additional DEVELOPMENT review in accordance with §15.2.1 Special Permits.
- b. USE Limitations
  - i. The USE of any GROUND STORY commercial space fronting a PEDESTRIAN STREET, excluding lobbies for UPPER STORY USES, is limited to the following PRINCIPAL USE categories:
    - a). Arts & Creative Enterprise
    - b). Food & Beverage Service
    - c). Retail
    - d). Civic & Institutional
- c. Required USES
  - i. A minimum of five percent (5%) of the gross leasable commercial floor space in any BUILDING must be provided as LEASABLE FLOOR AREA for USES from the Arts & Creative Enterprise USE category.
- d. Increases in Density
  - i. Existing STRUCTURES may not be altered to conflict with number of DWELLING UNITS permitted for each BUILDING TYPE.

**Table 4.3.13 Permitted Uses**

Use Category Specific Use	MR5
<b>Arts &amp; Creative Enterprise</b>	
Artisinal Production	P
Arts Exhibition	P
Arts Sales & Services	P
Co-working	P
Design Services	P
Shared Workspaces & Arts Education	P
<b>Cannabis Establishment</b>	
Cannabis Cultivation	P
Cannabis Retail Sales	SP
Cannabis Research & Development	P
Cannabis Testing Laboratory	P
<b>Civic &amp; Institutional</b>	
Community Center	P
Hospital	SP
Library	P
Minor Utility Facility	SP
Museum	P
Private Non-Profit Club or Lodge	SP
Public Service	P
Religious & Educational Uses Protected by M.G.L. 40A. Sec. 3	P

P - Permitted    SP - Special Permit Required    N - Not Permitted

**Table 4.3.13 Permitted Uses (continued)**

Use Category Specific Use	MR5
<b>Commercial Services</b>	
Animal Services (as noted below)	--
Commercial Kennel	SP
Pet Grooming	P
Pet Daycare & Training	SP
Veterinarian	SP
Assembly or Entertainment	SP
Banking & Financial Services (except as noted below)	P
Personal Credit	SP
Broadcast and/or Recording Studio	P
Building & Home Repair Services	SP
Business Support Services	P
Caterer/Wholesale Food Production	SP
Day Care Service (as noted below)	--
Adult Day Care Center	P
Child Day Care Center	P
Educational Services	P
Maintenance & Repair of Consumer Goods	P
Personal Services (except as noted below)	P
Body-Art Services	SP
Fitness Services	P
Funeral Services	SP
Health Care Services	SP
Formula Personal Services	SP
Recreation Services	SP
Vehicle Parking (except as follows)	--
Bike Share Parking	P
Car Share Parking (3 or fewer spaces)	P
Car Share Parking (4 or more spaces)	P
Commercial Parking	P
<b>Food and Beverage Service</b>	
Bar/Restaurant/Tavern	P
Bakery/Café/Coffee Shop	P
Formula Food & Beverage Service	SP

P - Permitted    SP - Special Permit Required    N - Not Permitted

**Table 4.3.13 Permitted Uses (continued)**

Use Category Specific Use	MR5
<b>Lodging</b>	
Bed & Breakfast	SP
Hotel or Hostel	SP
<b>Office</b>	
General Office	P
Research and Development or Laboratory	P
<b>Residential</b>	
Household Living	SP
Group Living (except as follows)	SP
Community or Group Residence	P
Dormitory, Fraternity or Sorority	SP
Homeless Shelter	SP
Nursing Home/Assisted Living Facility	SP
Rooming House	SP
<b>Retail Sales</b>	
Building/Home Supplies & Equipment	SP
Consumer Goods (except as follows)	P
Alcohol Sales	SP
Firearms Sales	N
Pet Store	SP
Formula Retail	SP
Fresh Food Market or Grocery Store	P
Farm/Vendor Market	P
<b>Urban Agriculture</b>	
Farming (as noted below)	--
Commercial Farming	P
Community Farming	P
Community Gardening	P

P - Permitted    SP - Special Permit Required    N - Not Permitted



# 4. MID-RISE DISTRICTS

Mid-Rise 5 (MR5)

**Table 4.3.13 Permitted Uses (continued)**

Use Category Specific Use	MR5
<b>Accessory Uses</b>	
<b>Home Occupations (as noted below)</b>	--
Home Office	P
<b>Urban Agriculture (as noted below)</b>	--
Apiculture	P
Aviculture	P
Commercial Farming	P
Residential Gardening	P
<b>Vehicle Parking, Accessory</b>	P
Home Business Vehicle Parking	N

P - Permitted    SP - Special Permit Required    N - Not Permitted

## 14. Development Standards

- a. General
  - i. DEVELOPMENT is subject to the provisions of Article 10: DEVELOPMENT STANDARDS of this Ordinance. Where the provisions of this section conflict with those of Article 10, the provisions of Article 10 apply.
- b. SIGNS
  - i. A SIGN, individual numerals or letters, or a nonelectrical nameplate identifying the property address is required for all real property as follows:
    - a). Each GROUND STORY non-residential USE must identify the STREET address either on the PRINCIPAL ENTRANCE door or above or beside the PRINCIPAL ENTRANCE of the USE.
    - b). All residential BUILDING TYPES must identify the STREET address either on the PRINCIPAL ENTRANCE door, above or beside the PRINCIPAL ENTRANCE, or on a mailbox.
  - ii. Address SIGNS must be made easily visible through the USE of colors or materials that contrast with the background material they are attached to and must be conspicuously located to provide visibility from the THOROUGHFARE that the BUILDING faces.
  - iii. Address SIGNS must be twelve (12) inches in height or less and may include the name of the occupant.





# 4. MID-RISE DISTRICTS

Mid-Rise 5 (MR5)

**Table 4.3.15 Vehicular Parking**

Use Category Specific Use	BICYCLE		MOTOR VEHICLE	
	Short-Term (min)	Long-Term (min)	Within a TRANSIT AREA <sup>1</sup> (max)	Outside of a TRANSIT AREA <sup>1</sup> (min)
<b>Arts &amp; Creative Enterprise</b>				
All Permitted Uses	1 / 10,000 sf	1 / 3,000 sf	1 / 800 sf	1 / 1,000 sf
<b>Cannabis Establishment</b>				
Cannabis Retail Sales	1 / 2,500 sf	1 / 10,000 sf	1 / 1,500 sf	1 / 750 sf
Cannabis Research & Development	1 / 20,000 sf	1 / 5,000 sf	1 / 1,000 sf	1 / 1,000 sf
Cannabis Testing Laboratory	1 / 20,000 sf	1 / 5,000 sf	1 / 1,000 sf	1 / 1,000 sf
<b>Civic &amp; Institutional</b>				
COMMUNITY CENTER	1 / 10,000 sf	4 / 10,000 sf	1 / 1,800 sf	1 / 600 sf
Educational Facility	1.0 / classroom	4.0 / classroom	1.5 / classroom	3.0 / classroom
HOSPITAL	10 per entrance	1 / 5,000 sf	1 / 200 sf	1 / 1,000 sf
LIBRARY	1 / 3,000 sf	1 / 5,000 sf	1 / 800 sf	1 / 500 sf
MINOR UTILITY FACILITY	n/a	n/a	n/a	n/a
MUSEUM	1 / 2,000 sf	1 / 10,000 sf	1 / 800 sf	1 / 500 sf
Private Non-Profit Club or Lodge	1 / 2,000 sf	1 / 10,000 sf	1 / 200 sf	1 / 1,000 sf
<b>Commercial Services</b>				
Animal Services (as noted below)	–	–	–	–
Commercial Kennel	1 / 2,500 sf	1 / 10,000 sf	1 / 500 sf	1 / 500 sf
Pet Grooming	1 / 2,500 sf	none	1 / 500 sf	1 / 500 sf
Pet Day Care or Training	1 / 2,500 sf	none	1 / 500 sf	1 / 500 sf
Veterinarian	1 / 2,500 sf	1 / 5,000 sf	1 / 500 sf	1 / 500 sf
ASSEMBLY OR ENTERTAINMENT	1 / 40 seats	1 / 10,000 sf	1 / 6 seats	1 / 6 seats
Banking & Financial Services (except as noted below)	1 / 2,000 sf	1 / 10,000 sf	1 / 450 sf	1 / 400 sf
Broadcast and/or Recording Studio	1 / 2,500 sf	1 / 10,000 sf	1 / 800 sf	1 / 600 sf
BUILDING & Home Repair Services	1 / 2,500 sf	1 / 10,000 sf	1 / 1,000 sf	1 / 2,000 sf
BUSINESS SUPPORT SERVICES	1 / 2,500 sf	1 / 10,000 sf	1 / 900 sf	1 / 600 sf
Caterer/Wholesale Food Production	1 / 2,500 sf	1 / 10,000 sf	1 / 800 sf	1 / 1,000 sf
Day Care Service	2	1 / 10,000 sf	1 / 900 sf	1 / 600 sf
Maintenance & Repair of CONSUMER GOODS	1 / 2,500 sf	1 / 10,000 sf	1 / 750 sf	1 / 1,000 sf
PERSONAL SERVICES (except as noted below)	1 / 2,500 sf	1 / 10,000 sf	1 / 750 sf	1 / 1,000 sf
Health Care Services	1 / 2,000 sf	1 / 10,000 sf	1 / 500 sf	1 / 300 sf
Recreation Services	1 / 2,500 sf	1 / 10,000 sf	–	–

sf - Gross Leasable Square Footage

DU - DWELLING UNIT

RU - ROOMING UNIT

<sup>1</sup> See the TRANSIT AREA Map

**Table 4.3.15 Vehicular Parking (continued)**

Use Category Specific Use	BICYCLE		MOTOR VEHICLE	
	Short-Term (min)	Long-Term (min)	Within a TRANSIT AREA <sup>1</sup> (max)	Outside of a TRANSIT AREA <sup>1</sup> (min)
<b>Food and Beverage Service</b>				
<b>All Permitted Uses</b>	1 / 1,000 sf	1 / 5,000 sf	1 / 300 sf	1 / 500 sf
<b>Lodging</b>				
BED & BREAKFAST	n/a	2.0	1 / DU + 1 / 4 guest rooms	1 / DU + 1 / 4 guest rooms
HOTEL OR HOSTEL	1 / 20 rooms	1 / 10 rooms	1 / 2 guest rooms	1 / 2 guest rooms
<b>Office</b>				
Co-WORKING	1 / 20,000 sf	1 / 3,000 sf	1 / 1,200 sf	1 / 800 sf
GENERAL OFFICE	1 / 20,000 sf	1 / 3,000 sf	1 / 900 sf	1 / 650 sf
<b>Research and Development or Laboratory</b>	1 / 20,000 sf	1 / 5,000 sf	1 / 1,000 sf	1 / 1,000 sf
<b>Residential</b>				
HOUSEHOLD LIVING	0.1 / DU	1.0 / DU	1.0 / DU	1.0 / DU
<b>GROUP LIVING (except as follows)</b>	0.05 / room	0.5 / room	--	--
COMMUNITY OR GROUP RESIDENCE	--	--	--	--
Dormitory, Fraternity or Sorority	0.1 / room	0.5 / room	.05 / bed	1.0 / 4 beds
HOMELESS SHELTER	--	--	4.0	4.0
Nursing Home/Assisted Living Facility	--	--	1 / 6 beds	1 / 6 beds
Single Room Occupancy Housing	--	--	1 / 6 beds	1 / 4 beds
<b>Retail Sales</b>				
<b>BUILDING/Home Supplies &amp; Equipment</b>	1 / 2,500 sf	1 / 10,000 sf	1 / 1,000 sf	1 / 1,000 sf
<b>CONSUMER GOODS (except as follows)</b>	1 / 2,500 sf	1 / 10,000 sf	1 / 1,500 sf	1 / 750 sf
FORMULA RETAIL	1 / 2,500 sf	1 / 10,000 sf	1 / 1,500 sf	1 / 750 sf
FRESH FOOD MARKET OR GROCERY STORE	1 / 1,000 sf	1 / 10,000 sf	1 / 500 sf	1 / 1,500 sf
<b>Farm/Vendor Market</b>	n/a	n/a	n/a	1 / 1,500 sf

sf - Gross Leasable Square Footage

DU - DWELLING UNIT

RU - ROOMING UNIT

<sup>1</sup> See the TRANSIT AREA Map

## 4. MID-RISE DISTRICTS

### Mid-Rise 5 (MR5)

poles, and other furnishings as deemed necessary by the City Engineer.

- a). CURB CUTS for commercial or high-volume driveways should be at least one-hundred (100) feet from an UNSIGNALIZED or SIGNALIZED intersection.
- b). CURB CUTS for residential driveways should be at least twenty (20) feet from an UNSIGNALIZED intersection and at least forty (40) feet from a SIGNALIZED intersection.
- v. The interior width of a CURB CUT (between curb stones) may be no wider than the driveway, vehicular entrance, or loading facility it serves.
- vi. A DRIVEWAY APRON may be installed only within the furnishing zone of a sidewalk and must be constructed in accordance with all standards established by relevant City Departments.
- vii. The grade, cross slope, and clear width of the walkway of a sidewalk must be maintained between the DRIVEWAY APRON and the ABUTTING driveway. The appearance of the walkway (ie. scoring pattern or paving material) must indicate that, although a vehicle may cross, the area traversed by a vehicle remains part of the sidewalk.

**Figure 4.3.16 Sidewalk Curb Cuts**

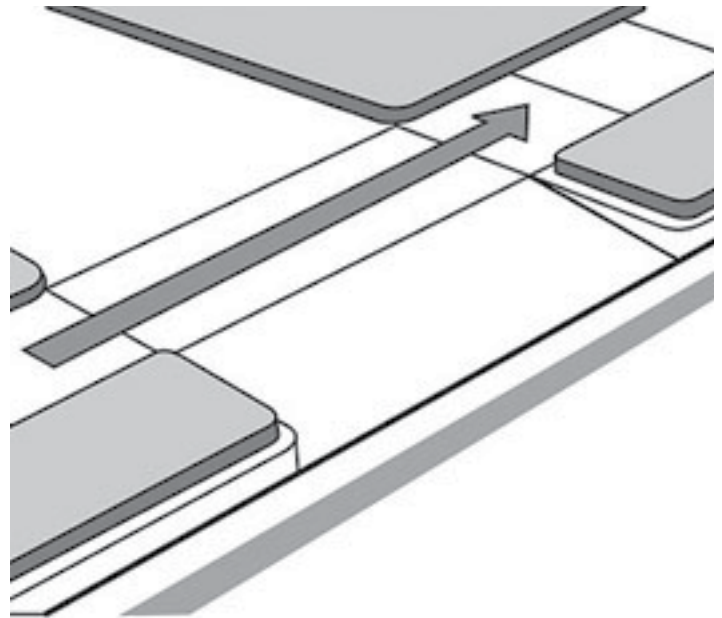

## 4.4 MID-RISE 6 (MR6)

### 1. Character Description

The Mid-Rise 6 district is characterized by a variety of moderate to large FLOOR PLATE buildings up to six (6) stories in height. Buildings are set close to the sidewalk to create a defined STREET wall that supports pedestrian activity and a sense of place. The district is primarily commercial, with a variety of employment opportunities and GROUND STORY USES that address the needs of residents and employees from the immediate neighborhood, but can also provide goods and services to the larger Somerville community and visitors from the broader Boston metropolitan area.

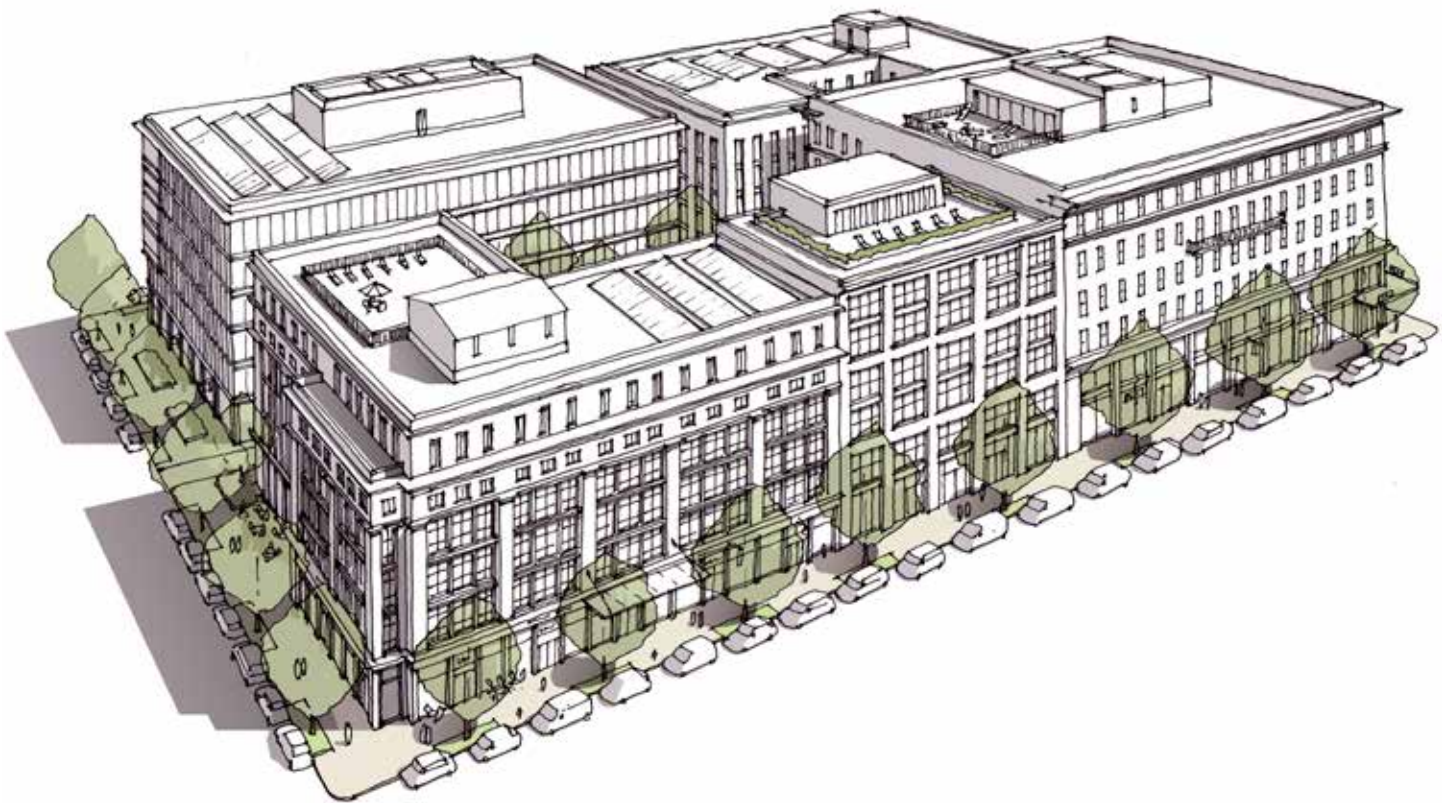

## 4. MID-RISE DISTRICTS

### Mid-Rise 6 (MR6)

#### 2. Intent

- a. To implement the objectives of the COMPREHENSIVE PLAN of the City of Somerville.
- b. To accommodate the DEVELOPMENT of areas appropriate for moderately-scaled multi-unit, mixed-USE, and commercial buildings; neighborhood-, community-, and region-serving USES; and a wide variety of employment opportunities.

#### 3. Purpose

- a. To permit the DEVELOPMENT of multi-unit, mixed-USE, and commercial buildings that do not exceed six (6) stories in height.
- b. To provide quality commercial spaces and permit small and medium-scale, neighborhood-, community-, and region-serving commercial USES.
- c. To create DWELLING UNIT types, sizes, and BEDROOM counts ideal for larger households in apartment buildings.
- d. To create DWELLING UNIT types, sizes, and BEDROOM counts ideal for smaller households in general buildings.
- e. To permit increased residential density for buildings that are sustainable or that provide 100% AFFORDABLE HOUSING.
- f. To permit increased residential density for buildings that meet the definition of a NET ZERO BUILDING or 100% AFFORDABLE HOUSING.

#### 4. Applicability

- a. The section is applicable to all real property within the Mid-Rise 6 district as shown on the maps of the Official Zoning Atlas of the City of Somerville.

#### 5. Development Review

- a. DEVELOPMENT review is subject to the provisions of Article 15: Administration of this Ordinance.
- b. All DEVELOPMENT, excluding NORMAL MAINTENANCE, requires the submittal of a development review application to the BUILDING OFFICIAL and the issuance of a Certificate of Zoning Compliance prior to the issuance of a BUILDING Permit or Certificate of Occupancy.
- c. Proposed DEVELOPMENT may or may not necessitate the need for SUBDIVISION Plan Approval, Site Plan Approval, a Special Permit, or a Hardship Variance based on the nature of the proposal. In such cases, additional DEVELOPMENT review is required in accordance with Article 15: Administration.
  - i. The Planning Board is the decision making authority for all DEVELOPMENT that requires Site Plan Approval or a Special Permit.
  - ii. The Zoning Board of Appeals is the Review Board for all HardSHIP Variances.
- d. Upon verification that no additional DEVELOPMENT review is necessary, or completion of the required DEVELOPMENT review, the BUILDING OFFICIAL shall issue a Zoning

Compliance CERTIFICATE to certify compliance with the provisions and procedures of this Ordinance.

#### 6. Building Types

- a. One (1) PRINCIPAL BUILDING TYPE is permitted on each LOT.
- b. The following BUILDING TYPES are permitted by Site Plan Approval in the Mid-Rise 6 district:
  - i. Apartment BUILDING
  - ii. General BUILDING
  - iii. Commercial BUILDING
  - iv. Lab BUILDING
- c. Apartment Buildings are prohibited on any LOT fronting a PEDESTRIAN STREET.
- d. ACCESSORY STRUCTURES are regulated according to Article 10: DEVELOPMENT Standards of this Ordinance.



## 4.4.7 Apartment Building

A large FLOOR PLATE, multi-STORY PRINCIPAL BUILDING TYPE purpose built for OCCUPATION by residential USES on all stories.

The following images are examples of the apartment BUILDING TYPE and are intended only for illustrative purposes.



# 4. MID-RISE DISTRICTS

Mid-Rise 6 (MR6)

## 4.4.7. Apartment Building (continued)

a. Lot Standards

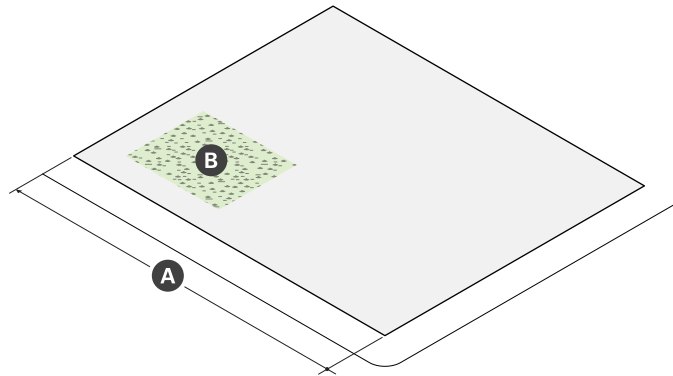

Lot Dimensions	
<b>A</b> LOT WIDTH (min)	30 ft

Lot Development	
LOT Coverage (max)	100%
GREEN SCORE	--
Minimum	0.20
Ideal	0.25
<b>B</b> OPEN SPACE (min)	15%

b. BUILDING Placement

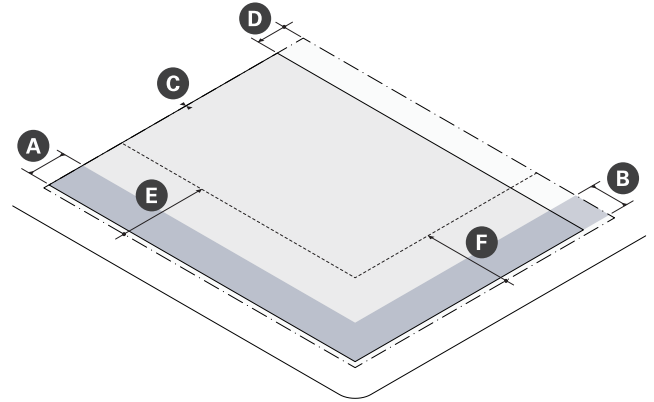

Building Setbacks		
<b>A</b> Primary Front SETBACK (min/max)	2 ft	12 ft
<b>B</b> Secondary Front SETBACK (min/max)	2 ft	12 ft
<b>C</b> Side SETBACK (min)	0 ft	
Side SETBACK ABUTTING NR or LHD (min)	10 ft	
<b>D</b> Rear SETBACK (min)	--	
ALLEY	0 ft	
No ALLEY	10 ft	
No ALLEY & ABUTTING NR or LHD	15 ft	

Parking Setbacks	
<b>E</b> Primary Front SETBACK (min)	--
SURFACE PARKING	30 ft
STRUCTURED PARKING	30 ft
<b>F</b> Secondary Front SETBACK (min)	--
SURFACE PARKING	10 ft
STRUCTURED PARKING	2 ft

## 4.4.7. Apartment Building (continued)

### c. Massing & Height

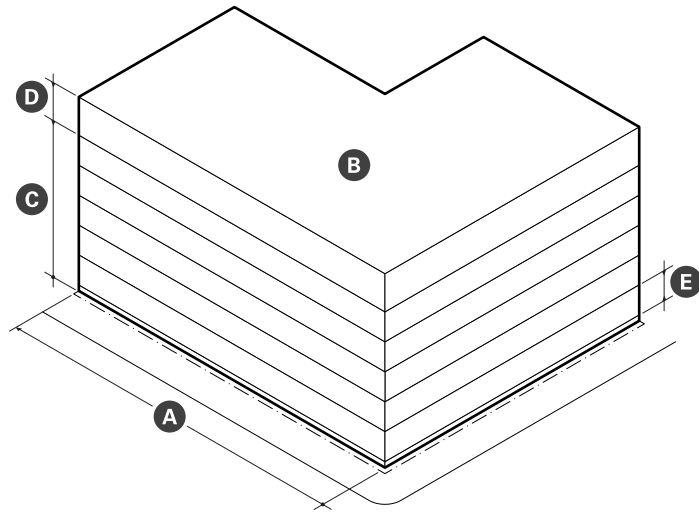

Main Massing	
<b>A</b> BUILDING WIDTH (max)	200 ft
FACADE Build Out	--
Primary Front	80%
Secondary Front	65%
<b>B</b> FLOOR PLATE (max)	25,000 sf
GROUND STORY Elevation (min)	2 ft
<b>E</b> STORY Height (min)	10 ft
<b>C</b> Number of Stories (min/max)	3   6
<b>D</b> UPPER STORY STEP-BACK (min)	--
Primary/Secondary Front	10 ft
Side/Rear ABUTTING NR	30 ft
<b>E</b> BUILDING Height, Feet	70 ft
Roof Type	Flat

### d. Uses & Features

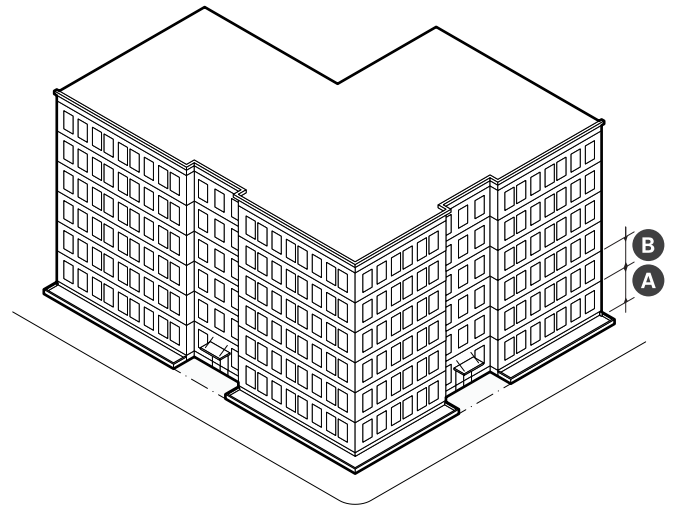

Facade Composition	
<b>A</b> GROUND STORY FENESTRATION (min/max)	20%   50%
<b>B</b> UPPER STORY FENESTRATION (min/max)	20%   50%
BLANK WALL (max)	20 ft

Use & Occupancy	
GROSS FLOOR AREA per DU	--
LOT AREA < 6,500 sf	1,125
LOT AREA >= 6,500 sf	850
NET ZERO BUILDING	650
100% AFFORDABLE HOUSING	650
Outdoor AMENITY SPACE (min)	1/DU

## 4. MID-RISE DISTRICTS

Mid-Rise 6 (MR6)

### 4.4.7. Apartment Building (continued)

- e. DEVELOPMENT Benefits
  - i. DEVELOPMENT is subject to the provisions of Article 12: DEVELOPMENT Benefits of this Ordinance. Where the provisions of this section conflict with those of Article 12, the provisions of Article 12 apply.
  - ii. DEVELOPMENT of a general building must provide AFFORDABLE DWELLING UNITS as specified on Table 4.4.7 (a).
- f. Design Guidelines
  - i. GROUND STORY DWELLING UNITS should be elevated above the grade of any adjacent sidewalk so that the window sills of the DWELLING UNIT are at or above the eye-level of passing pedestrians. This elevation change maintains privacy for occupants while also encouraging open blinds or curtains to allow natural daylight into the unit.
  - ii. FENESTRATION patterns and window configurations should break the direct line of sight between neighboring properties to every extent practicable. Translucent glass on the bottom half of windows or strategically placed landscape elements should be utilized if it is not practical to off-set windows in such a way as to minimize privacy impacts.
  - iii. Outdoor AMENITY SPACES that are elevated, such as roof DECKS, fully projecting balconies, and UPPER STORY rear porches should, provide sight-obscuring visual screening at the sides to increase privacy, security, and to limit views of ABUTTING properties from elevated vantage points.

Table 4.4.7 Required ADUs

Total DWELLING UNITS	Required ADUs
0 to 5 units	None
6 units	1 unit OR fractional buyout for 0.4 units
7 units	1 unit OR fractional buyout for 0.6 units
8 to 17 units	17.5% of units
18 or more units	20% of units



## 4.4.8 General Building

A large FLOOR PLATE, multi-STORY PRINCIPAL BUILDING TYPE with GROUND STORY commercial space and no limitations on the occupancy of UPPER STORIES for permitted USES. The UPPER STORIES of a general BUILDING are typically residential, but a wide variety exists. As the number of stories increases, it becomes more likely for the UPPER STORIES of a general BUILDING to host commercial USES as well as residential.

The following images are examples of the general BUILDING TYPE and are intended only for illustrative purposes.



# 4. MID-RISE DISTRICTS

Mid-Rise 6 (MR6)

## 4.4.8. General Building (continued)

a. Lot Standards

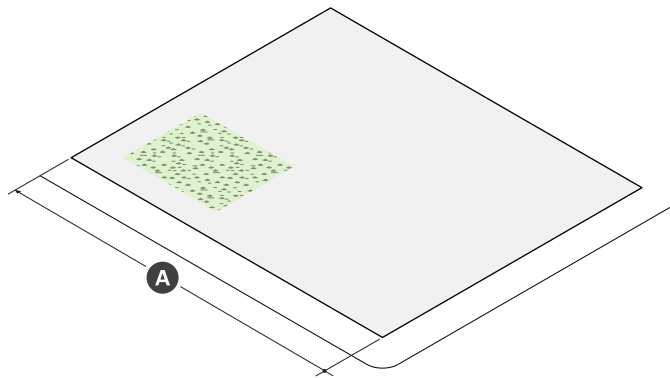

Lot Dimensions	
<b>A</b> LOT WIDTH (min)	30 ft

Lot Development	
LOT Coverage (max)	100%
GREEN SCORE	--
Minimum	0.20
Ideal	0.25
<b>B</b> OPEN SPACE (min)	15%

b. BUILDING Placement

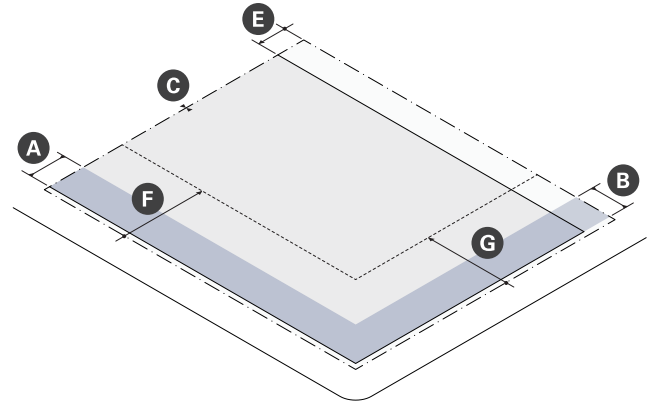

Building Setbacks		
<b>A</b> Primary Front SETBACK (min/max)	2 ft	15 ft
<b>B</b> Secondary Front SETBACK (min/max)	2 ft	15 ft
<b>C</b> Side SETBACK (min)	0 ft	
Side SETBACK ABUTTING NR or LHD (min)	10 ft	
<b>D</b> Rear SETBACK (min)	--	
ALLEY	0 ft	
No ALLEY	10 ft	
No ALLEY & ABUTTING NR or LHD	15 ft	

Parking Setbacks	
<b>E</b> Primary Front SETBACK (min)	--
SURFACE PARKING	30 ft
STRUCTURED PARKING	30 ft
<b>F</b> Secondary Front SETBACK (min)	--
SURFACE PARKING	10 ft
STRUCTURED PARKING	2 ft



## 4.4.8. General Building (continued)

### c. Massing & Height

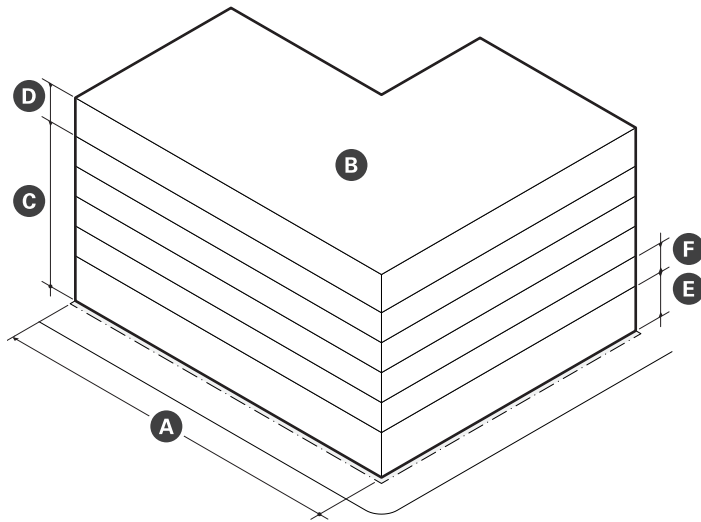

### d. Uses & Features

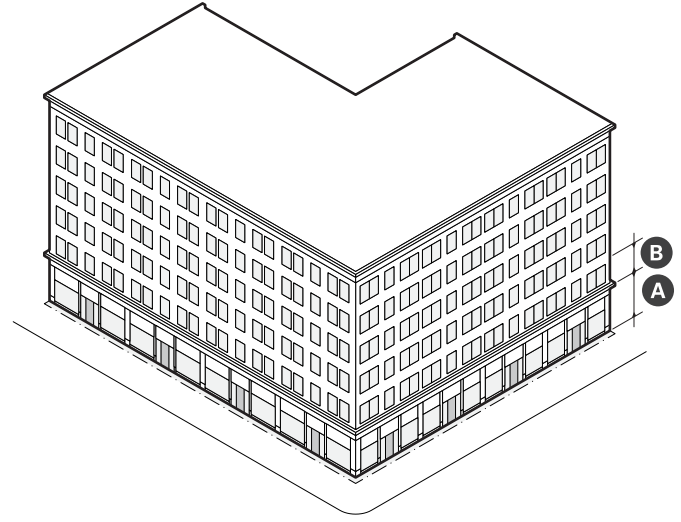

Main Massing	
<b>A</b> BUILDING WIDTH (max)	200 ft
FACADE Build Out (min)	--
Primary Front	80%
Secondary Front	65%
<b>B</b> FLOOR PLATE (max)	30,000 sf
<b>C</b> GROUND STORY Height	14 ft
<b>D</b> UPPER STORY Height	10 ft
<b>E</b> Number of Stories (min/max)	3   6
<b>F</b> UPPER STORY STEP-BACK (min)	--
Primary/Secondary Front	10 ft
Side/Rear ABUTTING NR	30 ft
<b>G</b> BUILDING Height, Feet (max)	75 ft
Roof Type	Flat

Facade Composition	
<b>A</b> GROUND STORY FENESTRATION (min)	70%
<b>B</b> UPPER STORY FENESTRATION (min/max)	20%   50%
BLANK WALL (max)	20 ft

Use & Occupancy	
GROUND STORY Entrance Spacing (max)	30 ft
Commercial Space Depth (min)	30 ft
GROSS FLOOR AREA per DU	--
LOT AREA < 6,500 sf	1,125
LOT AREA >= 6,500 sf	850
NET ZERO BUILDING	650
100% AFFORDABLE HOUSING	650
Outdoor AMENITY SPACE (min)	1/DU

# 4. MID-RISE DISTRICTS

Mid-Rise 6 (MR6)

## 4.4.8. General Building (continued)

- e. DEVELOPMENT Benefits
  - i. DEVELOPMENT is subject to the provisions of Article 12: DEVELOPMENT Benefits of this Ordinance. Where the provisions of this section conflict with those of Article 12, the provisions of Article 12 apply.
  - ii. DEVELOPMENT of a general building must provide AFFORDABLE DWELLING UNITS as specified on Table 4.4.8 (a).
  - iii. DEVELOPMENT of a general building must provide linkage payments as specified on Table 4.4.8 (b).
- f. Design Guidelines
  - i. FENESTRATION patterns and window configurations should break the direct line of sight between neighboring properties to every extent practicable. Translucent glass on the bottom half of windows or strategically placed landscape elements should be utilized if it is not practical to off-set windows in such a way as to minimize privacy impacts.
  - ii. Outdoor AMENITY SPACES that are elevated, such as roof DECKS, fully projecting balconies, and UPPER STORY rear porches should, provide sight-obscuring visual screening at the sides to increase privacy, security, and to limit views of ABUTTING properties from elevated vantage points.

**Table 4.4.8 (a) Required ADUs**

Total DWELLING UNITS	Required ADUs
0 to 5 units	None
6 units	1 unit OR fractional buyout for 0.4 units
7 units	1 unit OR fractional buyout for 0.6 units
8 to 17 units	17.5% of units
18 or more units	20% of units

**Table 4.4.8 (b) Linkage**

Commercial GROSS FLOOR AREA	Affordable Housing Linkage	Employment Linkage
30,000 sf or less	None	None
Over 30,000 sf	\$10/sf	\$2.46/sf

## 4.4.9 Commercial Building

A large FLOOR PLATE, multi-STORY PRINCIPAL BUILDING TYPE purpose built for OCCUPATION by commercial USES on all stories. GROUND STORY commercial space is primarily occupied by commercial service, food & beverage service, or retail sales PRINCIPAL USES. Floor space on upper stories may be occupied by retail USES that do not rely on the visibility of a storefront at sidewalk level.

The following images are examples of the commercial BUILDING TYPE and are intended only for illustrative purposes.



# 4. MID-RISE DISTRICTS

Mid-Rise 6 (MR6)

## 4.4.9. Commercial Building (continued)

a. Lot Standards

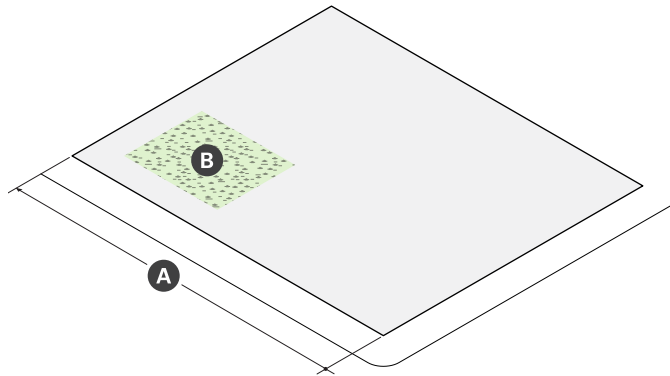

Lot Dimensions	
<b>A</b> LOT WIDTH (min)	30 ft

Lot Development	
LOT Coverage (max)	100%
GREEN SCORE	--
Minimum	0.20
Ideal	0.25
<b>B</b> OPEN SPACE (min)	15%

b. BUILDING Placement

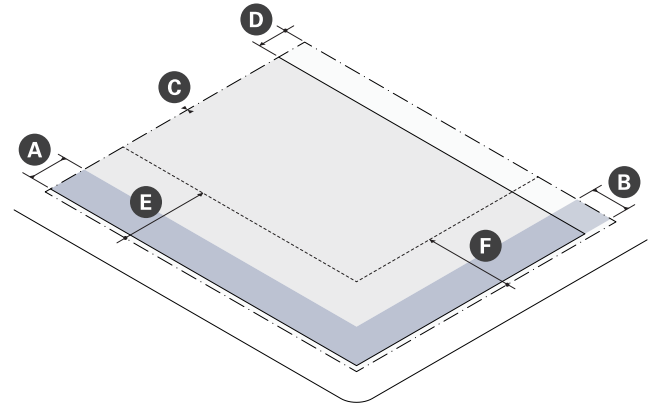

Building Setbacks		
<b>A</b> Primary Front SETBACK (min/max)	2 ft	15 ft
<b>B</b> Secondary Front SETBACK (min/max)	2 ft	15 ft
<b>C</b> Side SETBACK (min)	0 ft	
Side SETBACK ABUTTING NR or LHD (min)	10 ft	
<b>D</b> Rear SETBACK (min)	--	
ALLEY	0 ft	
No ALLEY	10 ft	
No ALLEY & ABUTTING NR or LHD	15 ft	

Parking Setbacks	
<b>E</b> Primary Front SETBACK (min)	--
SURFACE PARKING	30 ft
STRUCTURED PARKING	30 ft
<b>F</b> Secondary Front SETBACK (min)	--
SURFACE PARKING	10 ft
STRUCTURED PARKING	2 ft

## 4.4.9. Commercial Building (continued)

### c. Massing & Height

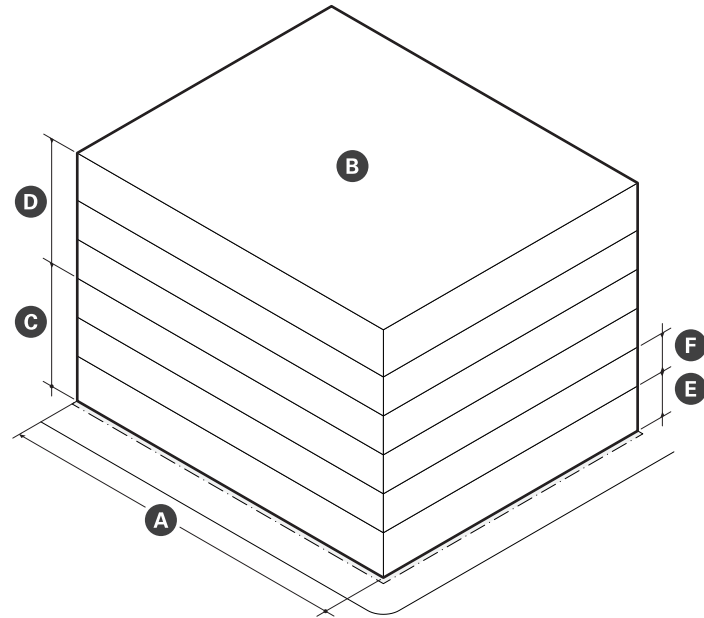

### d. Uses & Features

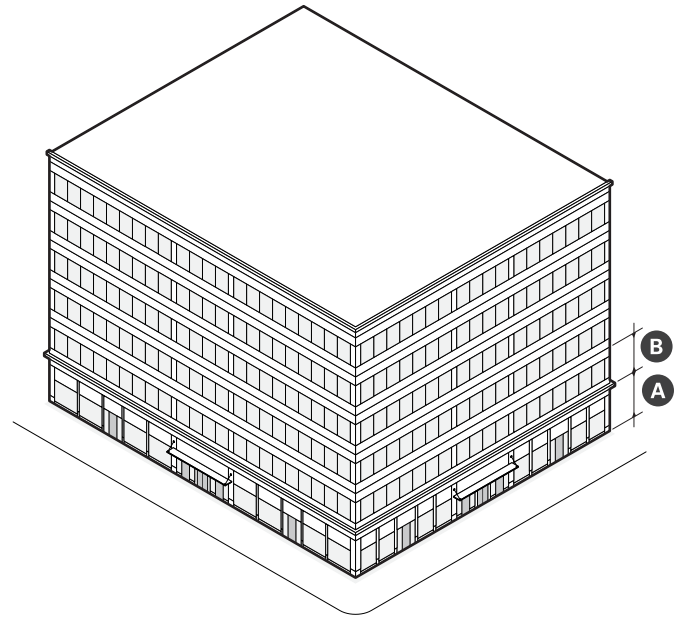

Main Massing	
<b>A</b> BUILDING WIDTH (max)	200 ft
FACADE Build Out (min)	–
Primary Front	80%
Secondary Front	65%
<b>B</b> FLOOR PLATE (max)	30,000 sf
<b>C</b> GROUND STORY Height	14 ft
<b>D</b> UPPER STORY Height	10 ft
<b>E</b> Number of Stories (min/max)	3   6
<b>F</b> UPPER STORY STEP-BACK (min)	–
Primary/Secondary Front	10 ft
Side/Rear ABUTTING NR	30 ft
<b>G</b> BUILDING Height, Feet (max)	85 ft
Roof Type	Flat

Facade Composition	
<b>A</b> GROUND STORY FENESTRATION (min)	70%
<b>B</b> UPPER STORY FENESTRATION (min/max)	20%   70%
BLANK WALL (max)	20 ft

Use & Occupancy	
GROUND STORY Entrance Spacing (max)	30 ft
Commercial Space Depth (min)	30 ft

## 4. MID-RISE DISTRICTS

Mid-Rise 6 (MR6)

### 4.4.9. Commercial Building (continued)

- e. DEVELOPMENT Benefits
  - i. DEVELOPMENT is subject to the provisions of Article 12: DEVELOPMENT Benefits of this Ordinance. Where the provisions of this section conflict with those of Article 12, the provisions of Article 12 apply.
  - ii. DEVELOPMENT of a general building must provide linkage payments as specified on Table 4.4.9.

**Table 4.4.9 Linkage**

<b>Commercial GROSS FLOOR AREA</b>	<b>Affordable Housing Linkage</b>	<b>Employment Linkage</b>
30,000 sf or less	None	None
Over 30,000 sf	\$10/sf	\$2.46/sf



## 4.4.10 Lab Building

A large FLOOR PLATE, multi-STORY PRINCIPAL BUILDING TYPE purpose built for occupation by laboratory and research & DEVELOPMENT PRINCIPAL USES. Floor space is typically custom designed as complex, technically sophisticated, and mechanically intensive wet or dry labs or vivariums for animal research.

The following images are examples of the lab BUILDING TYPE and are intended only for illustrative purposes.



# 4. MID-RISE DISTRICTS

Mid-Rise 6 (MR6)

## 4.4.10 Lab Building (continued)

### a. LOT Standards

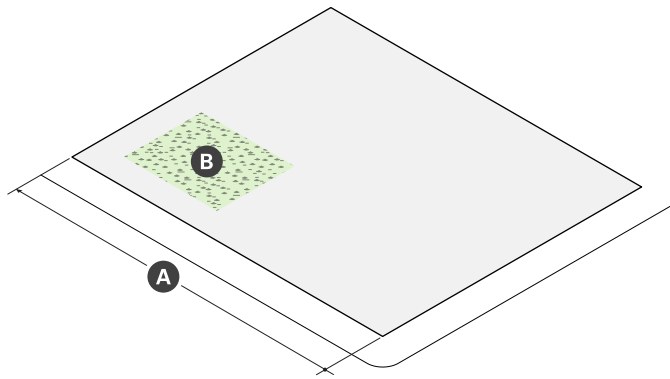

Lot Dimensions	
<b>A</b> LOT WIDTH (min)	30 ft

Lot Development	
LOT Coverage (max)	100%
GREEN SCORE	--
Minimum	0.20
Ideal	0.25
<b>B</b> OPEN SPACE (min)	15%

### b. BUILDING Placement

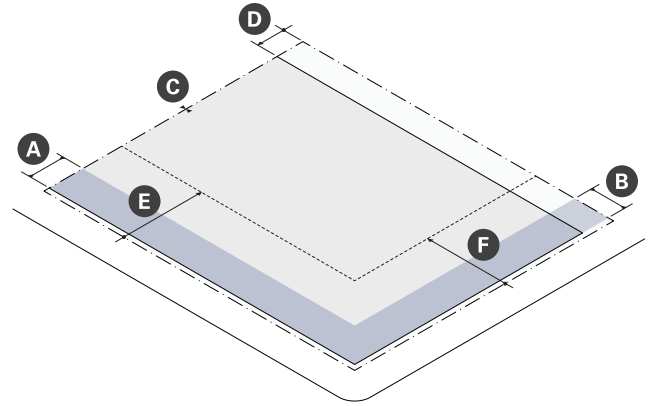

Building Setbacks		
<b>A</b> Primary Front SETBACK (min/max)	2 ft	15 ft
<b>B</b> Secondary Front SETBACK (min/max)	2 ft	15 ft
<b>C</b> Side SETBACK (min)	0 ft	
Side SETBACK ABUTTING NR or LHD (min)	5 ft	
<b>D</b> Rear SETBACK (min)	10 ft	
Rear SETBACK ABUTTING NR or LHD (min)	15 ft	

Parking Setbacks	
<b>E</b> Primary Front SETBACK (min)	30 ft
<b>F</b> Secondary Front SETBACK (min)	30 ft

## 4.4.10 Lab Building (continued)

### c. Massing & Height

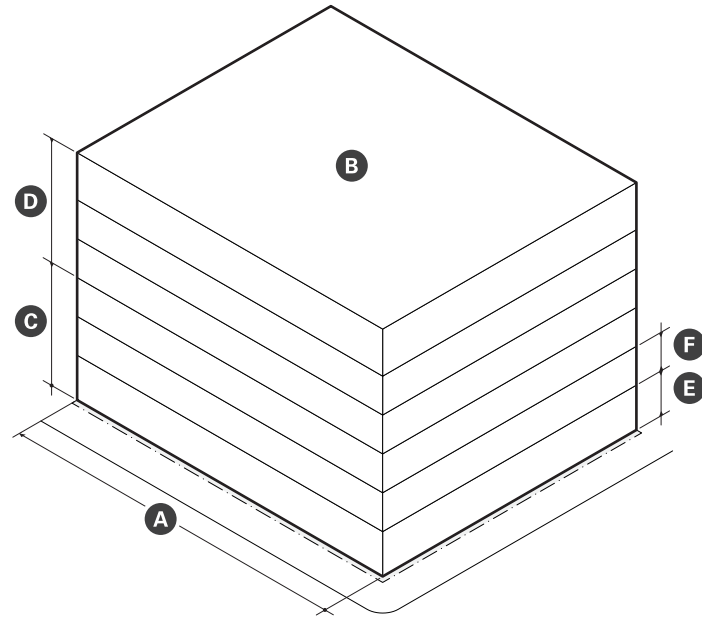

### d. Uses & Features

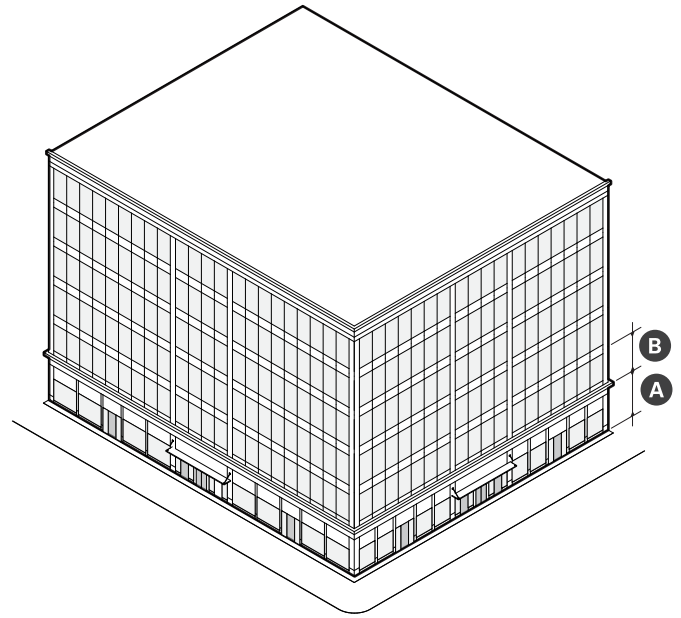

Main Massing	
<b>A</b> Width (max)	200 ft
FACADE Build Out	
Primary Front (min)	80%
Secondary Front (min)	65%
<b>B</b> FLOOR PLATE	30,000 sf
<b>C</b> GROUND STORY Height	14 ft
<b>D</b> UPPER STORY Height	10 ft
<b>E</b> Number of Stories (min)	3   6
<b>F</b> UPPER STORY STEP-BACK (min)	
Primary/Secondary Front	10 ft
Side/Rear ABUTTING NR	30 ft
<b>G</b> BUILDING Height, Feet (max)	95 ft
Roof Type	Flat

Facade Composition	
<b>A</b> GROUND STORY FENESTRATION (min)	70%
<b>B</b> UPPER STORY FENESTRATION (min/max)	20%   70%
BLANK WALL (max)	20 ft

Use & Occupancy	
Entrance Spacing (max)	30 ft
Commercial Space Depth (min)	30 ft

## 4. MID-RISE DISTRICTS

Mid-Rise 6 (MR6)

### 4.4.10 Lab Building (continued)

- e. DEVELOPMENT Benefits
  - i. DEVELOPMENT is subject to the provisions of Article 12: DEVELOPMENT Benefits of this Ordinance. Where the provisions of this section conflict with those of Article 12, the provisions of Article 12 apply.
  - ii. DEVELOPMENT of a general building must provide linkage payments as specified on Table 4.4.10.

**Table 4.4.10 Linkage**

<b>Commercial GROSS FLOOR AREA</b>	<b>Affordable Housing Linkage</b>	<b>Employment Linkage</b>
30,000 sf or less	None	None
Over 30,000 sf	\$10/sf	\$2.46/sf

**11. Building Components**

- a. BUILDING COMPONENTS are ACCESSORY elements attached to the MAIN MASSING of a PRINCIPAL BUILDING.
- b. BUILDING COMPONENTS are permitted by Site Plan Approval as specified on Table 4.4.11.
  - i. At least one (1) storefront is required for each GROUND STORY commercial space.
- c. BUILDING COMPONENTS not identified on Table 4.4.11 are prohibited.
- d. Unless otherwise specified, BUILDING COMPONENTS may attach to other BUILDING COMPONENTS to create assemblies of components.

**Table 4.4.11 Building Components**

	Apartment BUILDING	General BUILDING	Commercial BUILDING	Lab BUILDING
Awning	N	P	P	P
Entry Canopy	P	P	P	P
Lobby Entrance	P	P	P	P
Storefront	N	P	P	P
Stoop	P	N	N	N
Bay Window	P	P	P	P
Balcony	P	P	N	N
Arcade	N	N	N	N

P - Permitted      N - Not Permitted

# 4. MID-RISE DISTRICTS

## Mid-Rise 6 (MR6)

### e. Awning

- i. An awning is a wall mounted frame covered with fabric or other material that provides shade and weather protection over a storefront or BUILDING entrance.

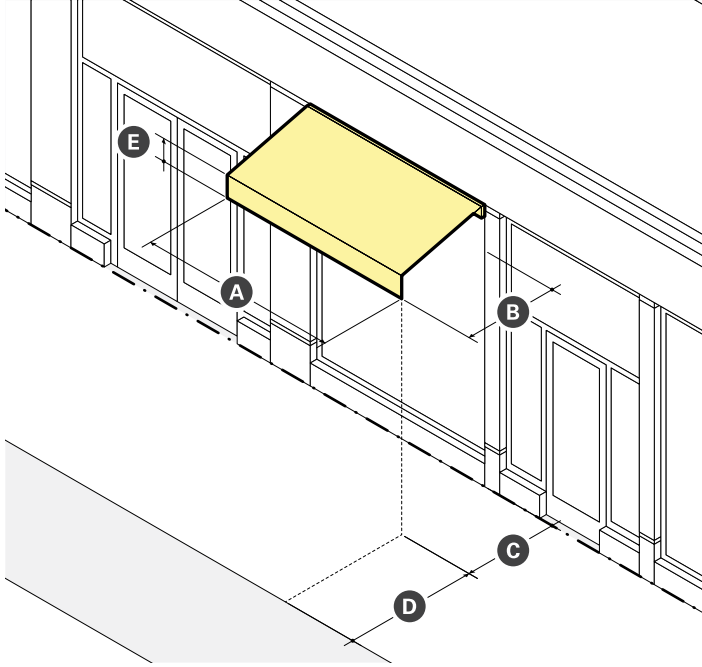

Dimensions	
<b>A</b> Width (min)	See ii. Standards
<b>B</b> Projection (min)	3 ft
<b>C</b> CLEARANCE (min)	8 ft
Front SETBACK ENCROACHMENT (max)	100%
<b>D</b> SETBACK from Curb (min)	2 ft
<b>E</b> Valance Height (max)	12 in

- ii. Standards
  - a). Awnings must be securely attached to and supported by the BUILDING and must fit the windows or doors the awning is attached to.
  - b). An awning must be made of durable, weather-resistant material that is water repellent.
  - c). Internally illuminated or back-lit awnings are prohibited.
  - d). An awning that projects over the sidewalk of a public THOROUGHFARE requires compliance with all City Ordinances.

### f. Entry Canopy

- i. An entry canopy is a wall-mounted STRUCTURE that provides shade and weather protection over a storefront or BUILDING entrance.

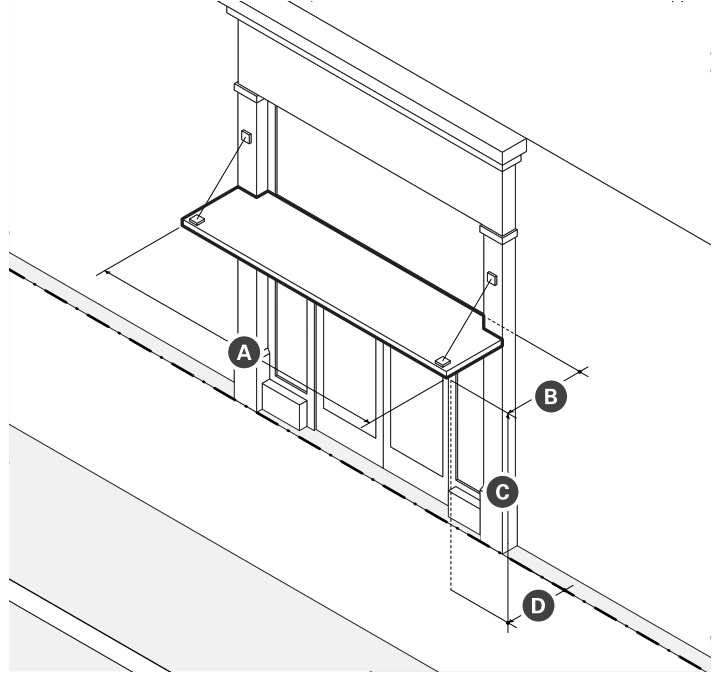

Dimensions	
<b>A</b> Width (min)	See ii. Standards
<b>B</b> Projection (min)	3 ft
<b>C</b> CLEARANCE (min)	8 ft
<b>D</b> Front SETBACK ENCROACHMENT (max)	100%
SETBACK from Curb (min)	2 ft

- ii. Standards
  - a). Entry canopies must be visually supported by brackets, cables, or rods.
  - b). The width of an entry canopy must be equal to or greater than the width of the doorway surround or exterior casing it is mounted over.



## g. Lobby Entrance

- i. A lobby entrance is a non-load bearing assembly of entry doors and windows providing ACCESS and light to the lobby of a BUILDING.

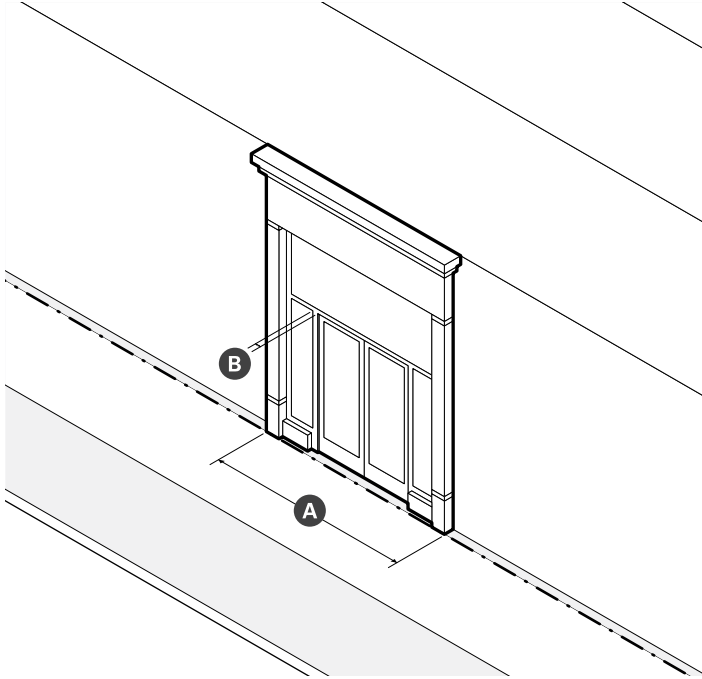

Dimensions		
<b>A</b> Width (min/max)	15 ft	30 ft
<b>B</b> Height (min)	80% of GROUND STORY Height	
Recessed Entrance Width (max)	15 ft	
Recessed Entrance Depth (max)	5 ft	

- ii. Standards
  - a). When a lobby entrance is set back from the FRONT LOT LINE, the FRONTAGE AREA must be paved.

## h. Storefront

- i. A storefront is a non-load bearing assembly of commercial entry doors and windows providing ACCESS and light to a commercial space and a place to display goods, services, and SIGNS.

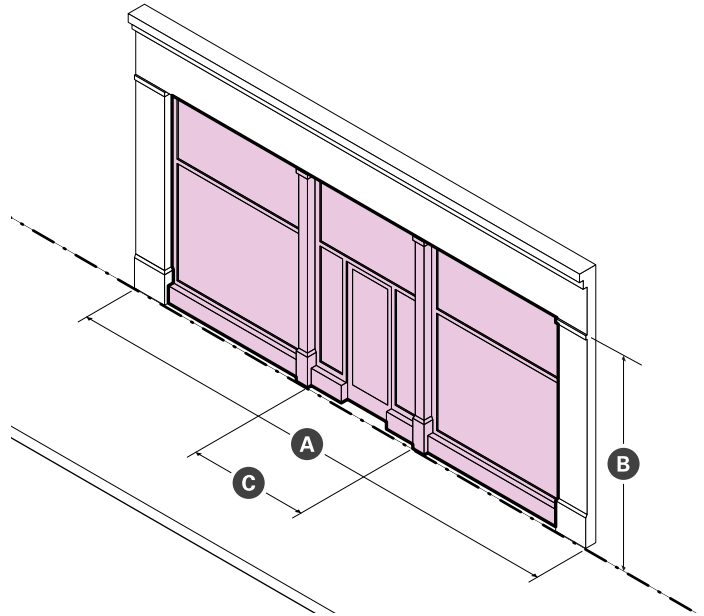

Dimensions		
<b>A</b> Width (min/max)	15 ft	30 ft
<b>B</b> Height (min)	80% of GROUND STORY Height	
Display Window Height (min)	8 ft	
Recessed Entrance Width (max)	15 ft	
Recessed Entrance Depth (max)	5 ft	

- ii. Standards
  - a). An unobstructed view of the interior space or a lighted and maintained merchandise display(s) must be provided for a depth of at least four (4) feet behind storefront display windows.
  - b). When storefronts are set back from the FRONT LOT LINE, the FRONTAGE AREA must be paved.
  - c). When present, awnings and canopies must be mounted between columns, PILASTERS, OR PIERS; above doorways and display windows; and below the SIGN BAND.
  - d). Exterior security grilles, gates, and roll-down security doors and windows are prohibited.

# 4. MID-RISE DISTRICTS

Mid-Rise 6 (MR6)

## i. Stoop

- i. A stoop is a set of stairs with a landing leading to the entrance of a BUILDING.

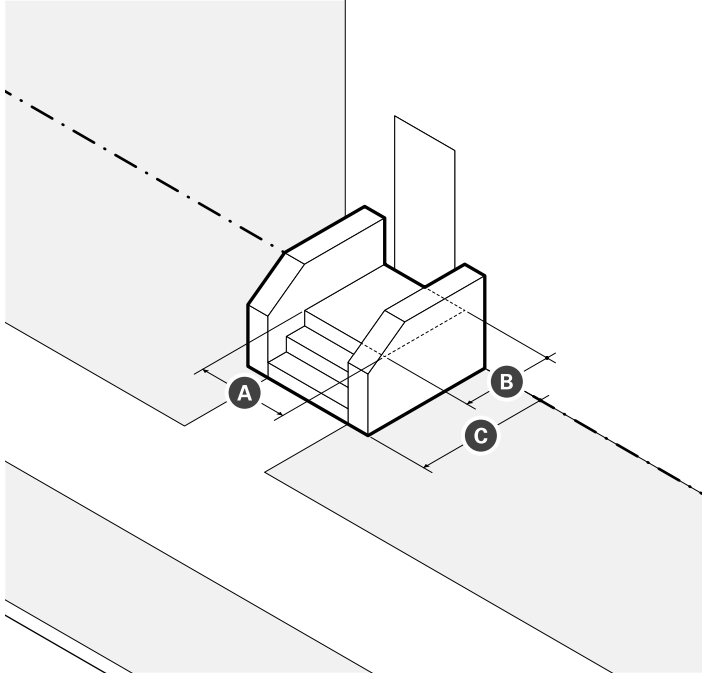

Dimensions	
<b>A</b> Landing Width (min)	4 ft
<b>B</b> Landing Depth (min)	4 ft
<b>C</b> Front SETBACK ENCROACHMENT (max)	100%

- ii. Standards
  - a). Paving, excluding driveways, must match the ABUTTING sidewalk unless paved with pervious, porous, or permeable materials.
  - b). Stairs may be recessed into the BUILDING FACADE when the BUILDING is set back four (4) feet or less.
  - c). Stairs are not permitted to ENCROACH onto any ABUTTING sidewalk.
  - d). Stairs may be built perpendicular or parallel to the BUILDING FACADE, but must lead directly to ground level or an ABUTTING sidewalk.

## j. Bay Window

- i. A bay window is an assembly of windows projecting from a building to provide additional HABITABLE space, increased light, multi-directional views, and ARTICULATION to an exterior wall.

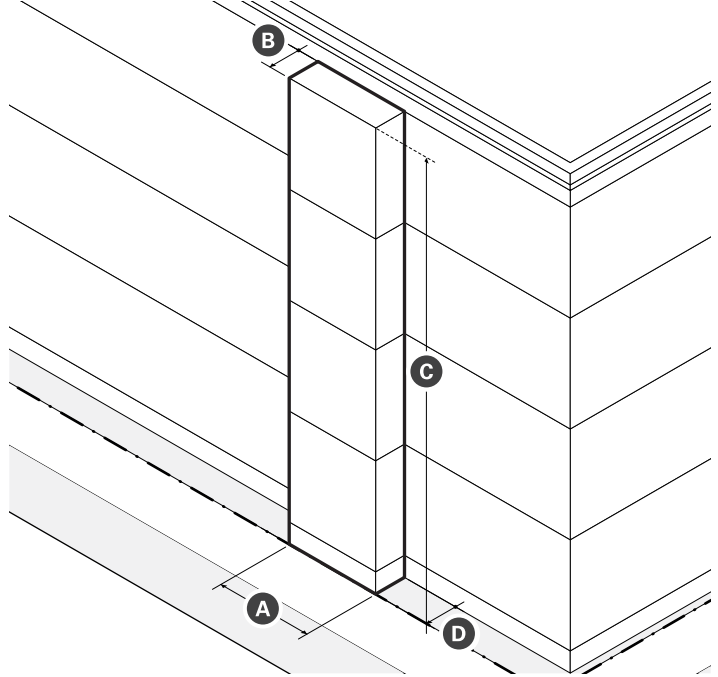

Dimensions	
<b>A</b> Width (max)	16 ft
<b>B</b> Projection (max)	3 ft
<b>C</b> Height (max)	Height of BUILDING in Stories
<b>D</b> Front SETBACK ENCROACHMENT (max)	3 ft
FENESTRATION (min)	60%

- ii. Standards
  - a). Bay windows, including box and bow windows, must include at least three (3) windows.
  - b). The cumulative width of multiple bays may equal up to fifty percent (50%) of the width of the exterior wall from which the bays project.
  - c). Bays projecting over the sidewalk of a public THOROUGHFARE must have at least two (2) stories of CLEARANCE and be compliant with all City Ordinances.

## k. Balcony

- i. A balcony is a platform with a railing that provides outdoor AMENITY SPACE.

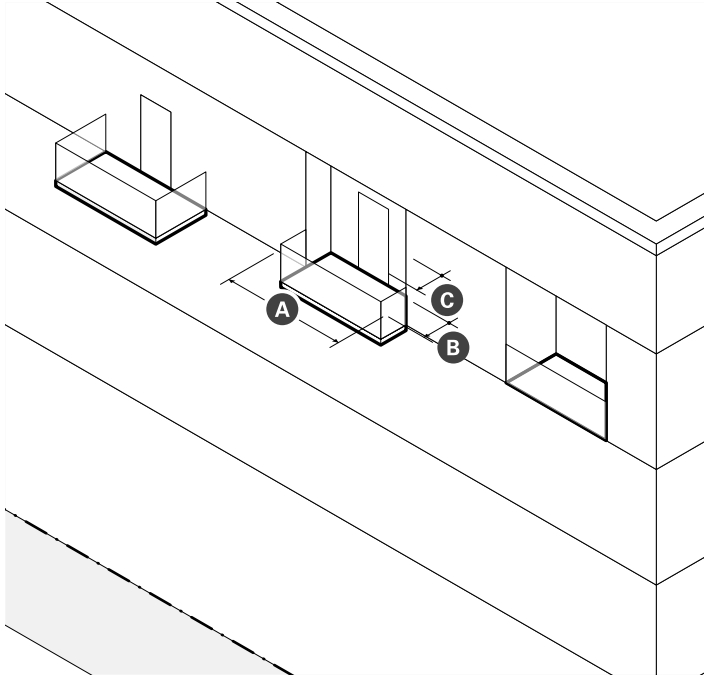

Dimensions	
<b>A</b> Width (min)	5 ft
<b>B</b> Depth (max)	5 ft
<b>D</b> Area (min)	50 ft
CLEARANCE (min)	10 ft
Permitted Front SETBACK ENCROACHMENT (max)	6 ft

- ii. Standards
  - a). Balconies may be recessed, projecting, a combination of the two, or terraced as part of the roof of a portico, porch, or bay.
  - b). A balcony that projects over the sidewalk of a public THOROUGHFARE requires compliance with all City Ordinances.
  - c). The guard rail of any balcony oriented toward a FRONT LOT LINE must permit visual supervision of the PUBLIC REALM through the posts and rails.
  - d). The guard rail of any balcony oriented toward a side OF REAR LOT LINE ABUTTING the NR district must include sight-obscuring visual screening so that it is at least fifty percent (50%) opaque.

## l. Arcade

- i. An arcade is a pedestrian walkway covered by the upper floors of a BUILDING. The GROUND STORY FACADE is SETBACK and upper floors are supported by a colonnade or supports.

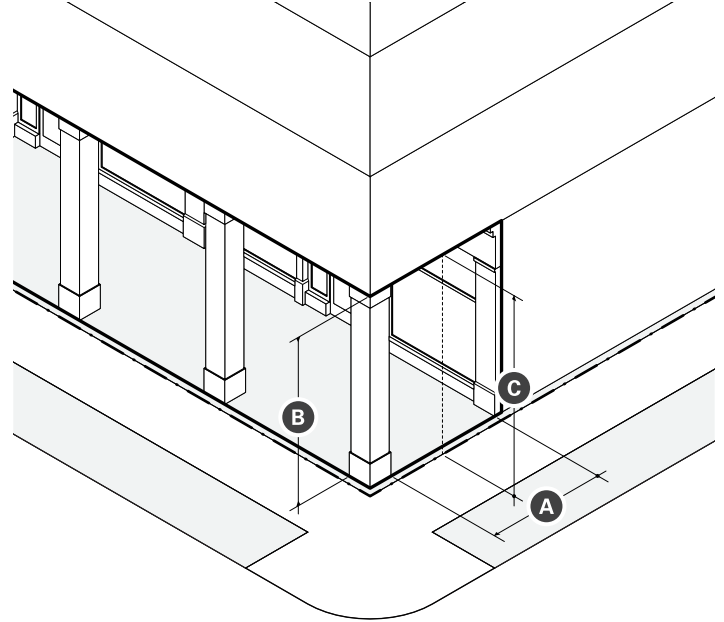

Dimensions		
<b>A</b> Depth (min/max)	10 ft	15 ft
<b>B</b> Height (max)	1 STORY	
<b>C</b> CLEARANCE (min/max)	14 ft	24 ft

- ii. Standards
  - a). Arcades must extend the entire width of a BUILDING and must have a consistent depth.
  - b). Support columns or PIERS may be spaced no farther apart than they are tall.
  - c). Arcades are considered part of the BUILDING for the purpose of measuring FACADE build out.
  - d). Arcades may be combined only with storefront and lobby entrance frontages.
  - e). The finished ceiling of an arcade interior may be arched or flat, but must have a greater CLEARANCE than the openings between columns OR PIERS.

## 4. MID-RISE DISTRICTS

### Mid-Rise 6 (MR6)

#### 12. Facade Design

- a. FACADES must provide solid material framing each storefront and lobby entrance as follows:
  - i. PILASTERS or columns supporting a horizontal lintel and CORNICE;
  - ii. a spandrel positioned between PILASTERS or columns that extend from upper stories of the building to the ground; or
  - iii. flat wall above and to either side of a void or punched opening.
- b. Storefronts and lobby entrances must be set within the resulting frame provided for each by the FACADE.
- c. Materials framing each storefront or lobby entrance may be integrated into the design of the FACADE or customized for individual storefronts and lobby entrances.
- d. Mechanical louvers necessary for venting purposes are not permitted in the required frame, but may be incorporated into any storefront or lobby entrance system.
- e. FACADES must differentiate the GROUND STORY of the building from the upper stories through horizontal ARTICULATION, a change in material, or a change in window size or pattern to create a distinct base to the building FACADE. The entire height of the GROUND STORY must be included in the FACADE base.
- f. Buildings of five (5) or more stories should include, at least, the entire height of the first two (2) stories in the required base. The design of the base may not shift up or down across the width of the FACADE.

- g. For buildings with more than one FACADE, the design of the base must align horizontally at the corner.
- h. FACADES must provide surface relief from the average plane of the FACADE by at least four (4) inches, through the USE of architectural elements such as bay windows, columns, CORNER BOARDS, CORNICES, door and window surrounds, moldings, PIERS, PILASTERS, recessed storefronts or lobby entrances, seat walls, sills, wall thickness, and recessed or projecting windows.
- i. The FACADE of any building greater than one hundred (100) feet in width must be designed as two (2) or more separate and distinct facades of differing architectural design so that the building appears to be multiple buildings. The facade designs must include a change in CORNICE, roof eave, or parapet design from one another.

#### 13. Architectural Design Guidelines

- a. FACADES should be visually divided into a series of ARCHITECTURAL BAYS that are derived, in general, from the building's structural bay spacing.
- b. PIERS, PILASTERS, or other features defining each ARCHITECTURAL BAY should either extend all the way to the ground or terminate at any horizontal ARTICULATION defining the base of the building.
- c. ARCHITECTURAL BAYS should align, in general, with individual or groups of storefronts and lobby entrances.
- d. PIERS, PILASTERS, or other features defining each ARCHITECTURAL BAY should always project forward and be uninterrupted by any horizontal articulation, excluding

Figure 4.4.12 (a) Storefront & Lobby Entrance Framing

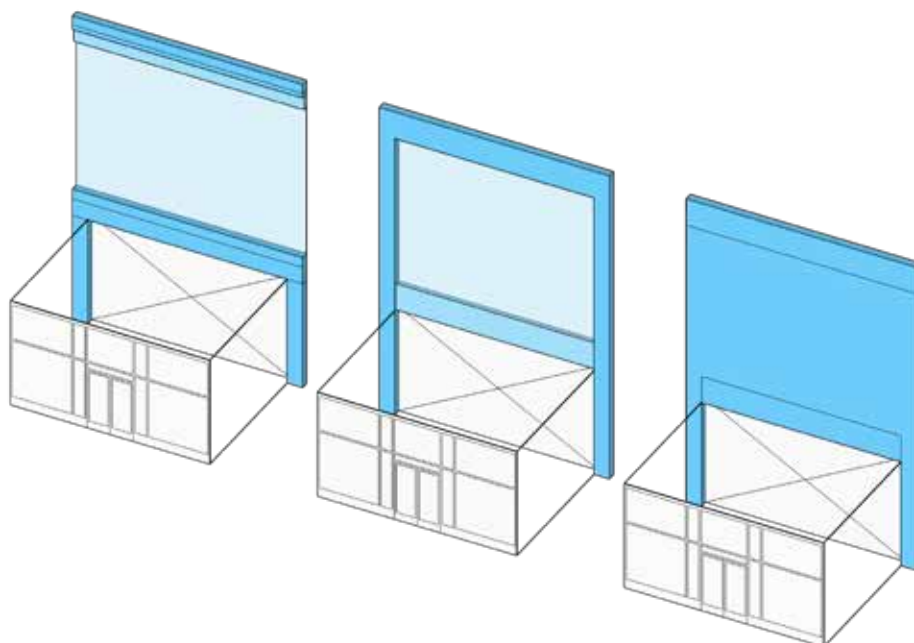

any horizontal ARTICULATION USED to differentiate the base of the building.

- e. The FACADE of buildings with five (5) or more stories should be visually divided into, at least, a horizontal tripartite division (a base, middle, and top). The horizontal divisions may not shift up or down across the width of the FACADE.
- f. Vents, exhausts, and other utility features on building FACADES should be architecturally integrated into the design of the building and should be located to minimize adverse effects on pedestrian comfort along sidewalks and within OPEN SPACES.
- g. Buildings at TERMINATED VISTAS should be ARTICULATED with design features that function as focal points.
- h. FENESTRATION glazing should be inset from the plane of exterior wall surfaces.
- i. RIBBON WINDOWS should be avoided.
- j. Monotonous and repetitive storefront or lobby systems, awnings, canopies, SIGN types, colors, or designs should be avoided.
- k. Storefronts and lobby entrances should include awnings or canopies to provide weather protection for pedestrians and reduce glare for storefront display areas. Awnings should be open-ended and operable.
- l. Lobby entrances for UPPER STORY USES should be optimally located, well defined, clearly visible, and separate from the entrance for other GROUND STORY USES.
- m. Lobbies should be limited in both width and total area to preserve floor space and frontage for other GROUND STORY USES. Buildings should USE any combination of FACADE ARTICULATION, a double-height ceiling, a distinctive doorway, a change in wall material, a change in paving material within the FRONTAGE AREA, or some other architectural element(s) to make lobbies visual and materially distinctive.
- n. The selection of materials, FENESTRATION, and ornamentation should result in a consistent and harmonious composition that appears as a unified whole rather than a collection of unrelated parts, no matter the style.
- o. The type and color of materials should be kept to a minimum, preferably three (3) or fewer.
- p. Two (2) or more wall materials should be combined only one above the other, except for bay windows.
- q. Wall materials appearing heavier in weight should be used below wall materials appearing lighter in weight (wood and metal above brick, and all three above stone)
- r. Horizontal or vertical board siding or shingles, regardless of material, should be avoided.
- s. Architectural details and finish materials for the base of a building should be constructed of architectural concrete or pre-cast cementitious panels, natural or cast stone, heavy gauge metal panels, glazed or unglazed architectural terracotta, or brick.
- t. Exterior Insulation and Finish Systems (EIFS) should be avoided.

**Figure 4.4.12 (b) Appearance of Two Buildings**





# 4. MID-RISE DISTRICTS

Mid-Rise 6 (MR6)

## 14. Use Provisions

- a. General
  - i. The USE of real property is subject to the provisions of Article 9: USE Provisions of this Ordinance. Where the provisions of this section conflict with those of Article 9, the provisions of Article 9 apply.
  - ii. USE categories are permitted as specified on Table 4.1.14. USE categories not identified on Table 4.1.14 are prohibited.
  - iii. All USES must comply with any USE-specific standards applicable for each USE in §9.2 USE Definitions & Limitations.
  - iv. USES permitted by Special Permit require additional DEVELOPMENT review in accordance with §15.2.1 Special Permits.
- b. USE Limitations
  - i. The USE of any GROUND STORY commercial space fronting a PEDESTRIAN STREET, excluding lobbies for UPPER STORY USES, is limited to the following PRINCIPAL USE categories:
    - a). Arts & Creative Enterprise
    - b). Food & Beverage Service
    - c). Retail Sales
    - d). Civic & Institutional
- c. Required USES
  - i. A minimum of five percent (5%) of the gross leasable commercial floor space in any BUILDING must be provided as LEASABLE FLOOR AREA for USES from the Arts & Creative Enterprise USE category.
- d. Increases in Density
  - i. Existing STRUCTURES may not be altered to conflict with number of DWELLING UNITS permitted for each BUILDING TYPE.

**Table 4.4.14 Permitted Uses**

Use Category Specific Use	MR6
<b>Arts &amp; Creative Enterprise</b>	
Artisinal Production	P
Arts Exhibition	P
Arts Sales & Services	P
Co-Working	P
Design Services	P
Shared Workspaces & Arts Education	P
<b>Cannabis Establishment</b>	
Cannabis Cultivation	P
Cannabis Retail Sales	SP
Cannabis Research & Development	P
Cannabis Testing Laboratory	P
<b>Civic &amp; Institutional</b>	
Community Center	P
Hospital	SP
Library	P
Minor Utility Facility	SP
Museum	P
Private Non-Profit Club or Lodge	SP
Public Service	P
Religious & Educational Uses Protected by M.G.L. 40A. Sec. 3	P

P - Permitted    SP - Special Permit Required    N - Not Permitted



**Table 4.4.14 Permitted Uses (continued)**

Use Category Specific Use	MR6
<b>Commercial Services</b>	
Animal Services (as noted below)	--
Commercial Kennel	SP
Pet Grooming	P
Pet Daycare & Training	SP
Veterinarian	SP
Assembly or Entertainment	SP
Banking & Financial Services (except as noted below)	P
Personal Credit	SP
Broadcast and/or Recording Studio	P
Building & Home Repair Services	SP
Business Support Services	P
Caterer/Wholesale Food Production	SP
Day Care Service (as noted below)	--
Adult Day Care Center	P
Child Day Care Center	P
Educational Services	P
Maintenance & Repair of Consumer Goods	P
Personal Services (except as noted below)	P
Body-Art Services	SP
Fitness Services	P
Funeral Services	SP
Health Care Services	SP
Formula Personal Services	SP
Recreation Services	SP
Vehicle Parking (as noted below)	--
Bike Share Parking	P
Car Share Parking (3 or fewer spaces)	P
Car Share Parking (4 or more spaces)	P
Commercial Parking	P
<b>Food and Beverage Service</b>	
Bar/Restaurant/Tavern	P
Bakery/Café/Coffee Shop	P
Formula Food & Beverage Service	SP

P - Permitted    SP - Special Permit Required    N - Not Permitted

**Table 4.4.14 Permitted Uses (continued)**

Use Category Specific Use	MR6
<b>Lodging</b>	
Bed & Breakfast	SP
Hotel or Hostel	SP
<b>Office</b>	
General Office	P
Research and Development or Laboratory	P
<b>Residential</b>	
Household Living	SP
Group Living (except as follows)	SP
Community or Group Residence	P
Dormitory, Fraternity or Sorority	SP
Homeless Shelter	SP
Nursing Home/Assisted Living Facility	SP
Rooming House	SP
<b>Retail Sales</b>	
Building/Home Supplies & Equipment	SP
Consumer Goods (except as follows)	P
Alcohol Sales	SP
Firearms Sales	N
Pet Store	SP
Formula Retail	SP
Fresh Food Market or Grocery Store	P
Farm/Vendor Market	P
<b>Urban Agriculture</b>	
Farming (as noted below)	--
Commercial Farming	P
Community Farming	P
Community Gardening	P

P - Permitted    SP - Special Permit Required    N - Not Permitted

# 4. MID-RISE DISTRICTS

Mid-Rise 6 (MR6)

**Table 4.4.14 Permitted Uses (continued)**

Use Category Specific Use	MR6
<b>Accessory Uses</b>	
Home Occupations (as noted below)	--
Home Office	P
Urban Agriculture (as noted below)	--
Apiculture	P
Aviculture	P
Commercial Farming	P
Residential Gardening	P

P - Permitted    SP - Special Permit Required    N - Not Permitted

## 15. Development Standards

- a. General
  - i. DEVELOPMENT is subject to the provisions of Article 10: DEVELOPMENT STANDARDS of this Ordinance. Where the provisions of this section conflict with those of Article 10, the provisions of Article 10 apply.
- b. SIGNS
  - i. A SIGN, individual numerals or letters, or a nonelectrical nameplate identifying the property address is required for all real property as follows:
    - a). Each GROUND STORY non-residential USE must identify the STREET address either on the PRINCIPAL ENTRANCE door or above or beside the PRINCIPAL ENTRANCE of the USE.
    - b). All residential BUILDING TYPES must identify the STREET address either on the PRINCIPAL ENTRANCE door, above or beside the PRINCIPAL ENTRANCE, or on a mailbox.
  - ii. Address SIGNS must be made easily visible through the USE of colors or materials that contrast with the background material they are attached to and must be conspicuously located to provide visibility from the THOROUGHFARE that the BUILDING faces.
  - iii. Address SIGNS must be twelve (12) inches in height or less and may include the name of the occupant.

## 16. Parking & Mobility

- a. General
  - i. DEVELOPMENT is subject to the provisions of Article 11: Parking & Mobility of this Ordinance. Where the provisions of this section conflict with those of Article 11, the provisions of Article 11 apply.
  - ii. Vehicular parking must be provided as specified on Table 4.1 (d), except as follows:
    - a). Non-residential USES with five thousand (5,000) square feet or less of GROSS LEASABLE FLOOR AREA are exempt from any minimum requirements of Table 4.1. (d).
    - b). Any CHANGE IN USE within a non-residential STRUCTURE constructed before the effective date of this Ordinance, provided that the change is to a permitted USE, is exempt from any minimum requirements of Table 4.1 (d).
  - iii. There are no parking requirements for ACCESSORY USES.
  - iv. MOTOR VEHICLE PARKING spaces may be shared between USES on the same LOT and buildings on the same BLOCK in accordance with §11.3 SHARED PARKING.
- b. Type
  - i. MOTOR VEHICLE PARKING may be provided as above ground STRUCTURED PARKING or underground STRUCTURED PARKING. SURFACE PARKING is prohibited.
- c. Driveways
  - i. New driveways require a permit from the City Engineer.
  - ii. Driveways must be compliant with all City Ordinances and constructed in accordance with all standards established by relevant City Departments.
  - iii. Driveways are not permitted in the FRONTAGE AREA between a BUILDING and the FRONT LOT LINE.
  - iv. Driveways may be no wider than twenty four (24) feet in the FRONTAGE AREA of a LOT.
  - v. Driveways may provide ACCESS in whole or in part on or across an ABUTTING LOT(s), provided that an ACCESS EASEMENT exists between all PROPERTY OWNERS.
- d. Parking Design
  - i. The design of all parking is subject to §11.1 Bicycle Parking and §11.2 MOTOR VEHICLE PARKING of this Ordinance.
- e. Parking Location
  - i. Required vehicular parking, excluding any required handicapped parking, may be provided on a contiguous LOT under the same ownership as the LOT that the parking will serve as follows:
    - a). Pedestrian ACCESS to off-SITE vehicular parking must be via a paved sidewalk or walkway.
    - b). A lease, recorded covenant, or other comparable legal instrument guaranteeing long term USE of the SITE must be provided to the review board or BUILDING OFFICIAL and executed and filed with the Registry of Deeds.
  - ii. For real property located in more than one municipality, MOTOR VEHICLE PARKING need not be located within the City of Somerville.
- f. Unbundled Parking
  - i. MOTOR VEHICLE PARKING spaces must be rented or leased as an option rather than a requirement of the rental, lease, or purchase of a DWELLING UNIT or non-residential floor space.
  - ii. Bicycle parking must be provided at no cost or fee to customers, visitors, employees, tenants, and residents.
- g. Parking Relief
  - i. Relief from the parking standards of Table 4.4 (d) requires a Special Permit.
    - a). In addition to the review criteria for all Special Permits specified in §15.2.1.e. Review Criteria, the review board shall make findings considering the following in its discretion to approve or deny a special permit authorizing relief from the parking standards of Table 4.4 (d):
      - i). The supply and demand of on-STREET parking in the neighborhood, as determined through a parking study.
      - ii). MOBILITY MANAGEMENT programs and services provided by the APPLICANT to reduce the demand for parking.
      - iii). That parking provided in excess of any maximum permitted does not result in the increase in impervious LOT AREA.

## 17. Public Realm

- a. Sidewalks
  - i. When DEVELOPMENT OCCURS on any LOT ABUTTING a sidewalk that is less than twelve (12) feet in total width, the BUILDING must be set-back an additional distance to accommodate expansion of the ABUTTING sidewalk to a width of at least twelve (12) feet. The minimum and maximum front SETBACKS for each BUILDING TYPE are increased accordingly.
- b. Sidewalk CURB CUTS
  - i. A CURB CUT requires a permit from the City Engineer and must be compliant with all City Ordinances.
  - ii. Unless otherwise specified, the City Engineer may not permit more than one (1) CURB CUT per FRONT LOT LINE of a LOT.
  - iii. CURB CUTS are prohibited along all THOROUGHFARES designated as a PEDESTRIAN STREET.
  - iv. CURB CUTS must be located to minimize conflicts with pedestrians and bicyclists and must have a clear distance from fire hydrants, STREET TREES, utility

# 4. MID-RISE DISTRICTS

Mid-Rise 6 (MR6)

**Table 4.4.16 Vehicular Parking**

Use Category Specific Use	BICYCLE		MOTOR VEHICLE	
	Short-Term (min)	Long-Term (min)	Within a TRANSIT AREA <sup>1</sup> (max)	Outside of a TRANSIT AREA <sup>1</sup> (min)
<b>Arts &amp; Creative Enterprise</b>				
All Permitted Uses	1 / 10,000 sf	1 / 3,000 sf	1 / 800 sf	1 / 1,000 sf
<b>Cannabis Establishment</b>				
Cannabis Retail Sales	1 / 2,500 sf	1 / 10,000 sf	1 / 1,500 sf	1 / 750 sf
Cannabis Research & Development	1 / 20,000 sf	1 / 5,000 sf	1 / 1,000 sf	1 / 1,000 sf
Cannabis Testing Laboratory	1 / 20,000 sf	1 / 5,000 sf	1 / 1,000 sf	1 / 1,000 sf
<b>Civic &amp; Institutional</b>				
Community Center	1 / 10,000 sf	4 / 10,000 sf	1 / 1,800 sf	1 / 600 sf
Educational Facility	1.0 / classroom	4.0 / classroom	1.5 / classroom	3.0 / classroom
Hospital	10 per entrance	1 / 5,000 sf	1 / 200 sf	1 / 1,000 sf
Library	1 / 3,000 sf	1 / 5,000 sf	1 / 800 sf	1 / 500 sf
Minor Utility Facility	n/a	n/a	n/a	n/a
Museum	1 / 2,000 sf	1 / 10,000 sf	1 / 800 sf	1 / 500 sf
Private Non-Profit Club or Lodge	1 / 2,000 sf	1 / 10,000 sf	1 / 200 sf	1 / 1,000 sf
<b>Commercial Services</b>				
Animal Services (as noted below)	–	–	–	–
Commercial Kennel	1 / 2,500 sf	1 / 10,000 sf	1 / 500 sf	1 / 500 sf
Pet Grooming	1 / 2,500 sf	none	1 / 500 sf	1 / 500 sf
Pet Day Care or Training	1 / 2,500 sf	none	1 / 500 sf	1 / 500 sf
Veterinarian	1 / 2,500 sf	1 / 5,000 sf	1 / 500 sf	1 / 500 sf
Assembly or Entertainment	1 / 40 seats	1 / 10,000 sf	1 / 6 seats	1 / 6 seats
Banking & Financial Services (except as noted below)	1 / 2,000 sf	1 / 10,000 sf	1 / 450 sf	1 / 400 sf
Broadcast and/or Recording Studio	1 / 2,500 sf	1 / 10,000 sf	1 / 800 sf	1 / 600 sf
Building & Home Repair Services	1 / 2,500 sf	1 / 10,000 sf	1 / 1,000 sf	1 / 2,000 sf
Business Support Services	1 / 2,500 sf	1 / 10,000 sf	1 / 900 sf	1 / 600 sf
Caterer/Wholesale Food Production	1 / 2,500 sf	1 / 10,000 sf	1 / 800 sf	1 / 1,000 sf
Day Care Service	2	1 / 10,000 sf	1 / 900 sf	1 / 600 sf
Maintenance & Repair of Consumer Goods	1 / 2,500 sf	1 / 10,000 sf	1 / 750 sf	1 / 1,000 sf
Personal Services (except as noted below)	1 / 2,500 sf	1 / 10,000 sf	1 / 750 sf	1 / 1,000 sf
Health Care Services	1 / 2,000 sf	1 / 10,000 sf	1 / 500 sf	1 / 300 sf
Recreation Services	1 / 2,500 sf	1 / 10,000 sf	–	–

sf - Gross Leasable Square Footage    DU - Dwelling Unit    RU - Rooming Unit

<sup>1</sup> See the Transit Area Map

**Table 4.4.16 Vehicular Parking (continued)**

Use Category Specific Use	BICYCLE		MOTOR VEHICLE	
	Short-Term (min)	Long-Term (min)	Within a TRANSIT AREA <sup>1</sup> (max)	Outside of a TRANSIT AREA <sup>1</sup> (min)
<b>Food and Beverage Service</b>				
All Permitted Uses	1 / 1,000 sf	1 / 5,000 sf	1 / 300 sf	1 / 500 sf
<b>Lodging</b>				
Bed & Breakfast	none	2 / 10 rooms	1 / 4 rooms	1 / 4 rooms
Hotel or Hostel	1 / 20 rooms	1 / 10 rooms	1 / 2 rooms	1 / 2 rooms
<b>Office</b>				
Co-Working	1 / 20,000 sf	1 / 3,000 sf	1 / 1,200 sf	1 / 800 sf
General Office	1 / 20,000 sf	1 / 3,000 sf	1 / 900 sf	1 / 650 sf
Research and Development or Laboratory	1 / 20,000 sf	1 / 5,000 sf	1 / 1,000 sf	1 / 1,000 sf
<b>Residential</b>				
Household Living	0.1 / DU	1.0 / DU	1.0 / DU	1.0 / DU
Group Living (except as follows)	0.05 / room	0.5 / room	–	–
Community or Group Residence	–	–	–	–
Dormitory, Fraternity or Sorority	0.1 / room	0.5 / room	.05 / bed	1.0 / 4 beds
Homeless Shelter	–	–	4.0	4.0
Nursing Home/Assisted Living Facility	–	–	1 / 6 beds	1 / 6 beds
Single Room Occupancy Housing	–	–	1 / 6 beds	1 / 4 beds
<b>Retail Sales</b>				
Building/Home Supplies & Equipment	1 / 2,500 sf	1 / 10,000 sf	1 / 1,000 sf	1 / 1,000 sf
Consumer Goods (except as follows)	1 / 2,500 sf	1 / 10,000 sf	1 / 1,500 sf	1 / 750 sf
Formula Retail	1 / 2,500 sf	1 / 10,000 sf	1 / 1,500 sf	1 / 750 sf
Fresh Food Market or Grocery Store	1 / 1,000 sf	1 / 10,000 sf	1 / 500 sf	1 / 1,500 sf
Farm/Vendor Market	n/a	n/a	n/a	1 / 1,500 sf

sf - Gross Leasable Square Footage    DU - Dwelling Unit    RU - Rooming Unit

<sup>1</sup> See the Transit Area Map

## 4. MID-RISE DISTRICTS

### Mid-Rise 6 (MR6)

poles, and other furnishings as deemed necessary by the City Engineer.

- a). CURB CUTS for commercial or high-volume driveways should be at least one-hundred (100) feet from an UNSIGNALIZED or SIGNALIZED intersection.
- b). CURB CUTS for residential driveways should be at least twenty (20) feet from an UNSIGNALIZED intersection and at least forty (40) feet from a SIGNALIZED intersection.
- v. The interior width of a CURB CUT (between curb stones) may be no wider than the driveway, vehicular entrance, or loading facility it serves.
- vi. A DRIVEWAY APRON may be installed only within the furnishing zone of a sidewalk and must be constructed in accordance with all standards established by relevant City Departments.
- vii. The grade, cross slope, and clear width of the walkway of a sidewalk must be maintained between the DRIVEWAY APRON and the ABUTTING driveway. The appearance of the walkway (ie. scoring pattern or paving material) must indicate that, although a vehicle may cross, the area traversed by a vehicle remains part of the sidewalk.

**Figure 4.4.17 Sidewalk Curb Cuts**

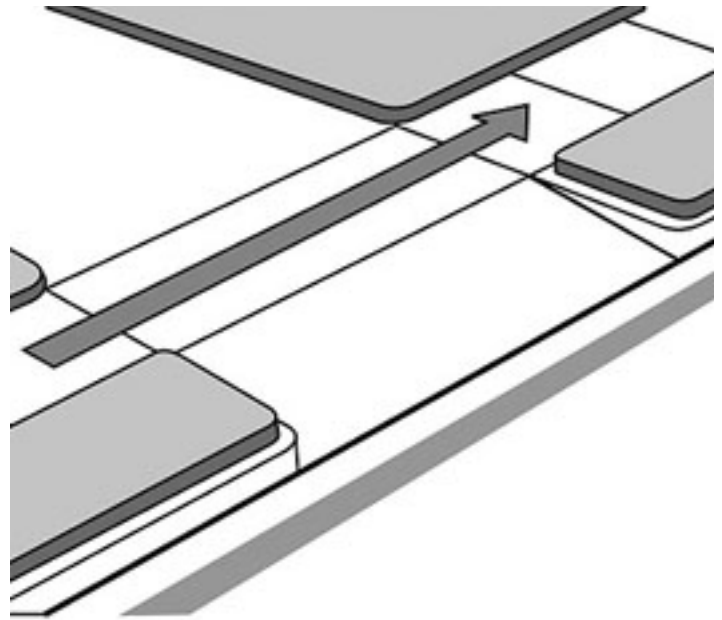



# 5 HIGH-RISE DISTRICTS

- 5.1 HIGH-RISE (HR) .....229**
  - Character Description 229
  - Intent 230
  - Purpose 230
  - Applicability 230
  - Development Review 230
  - Building Types 230
  - Building Components 251
  - Facade Design 256
  - Architectural Design Guidelines 256
  - Use Provisions 258
  - Development Standards 260
  - Parking & Mobility 261
  - Public Realm 261



## 5.1 HIGH-RISE (HR)

### 1. Character Description

The HIGH-RISE district is characterized by a variety of moderate to large FLOOR PLATE HIGH-RISE buildings. Buildings are set close to the sidewalk and have an UPPER STORIES stepped back to define a mid-rise STREET wall that supports pedestrian activity and a sense of place. The district is primarily commercial, with a variety of employment opportunities. GROUND STORY USES typically address the needs of residents and employees from the immediate neighborhood, but can also provide goods and services to the larger Somerville community and visitors from the broader Boston metropolitan area.



## 5. HIGH-RISE DISTRICTS

### High-Rise (HR)

#### 2. Intent

- a. To implement the objectives of the COMPREHENSIVE PLAN of the City of Somerville.
- b. To accommodate the DEVELOPMENT of areas appropriate for an intense mix of multi-STORY multi-unit, mixed-USE, and commercial buildings; neighborhood-, community-, and region-serving USES; and a wide variety of employment opportunities.

#### 3. Purpose

- a. To permit the DEVELOPMENT of multi-unit, mixed-USE, and commercial HIGH-RISE buildings.
- b. To provide quality commercial spaces and permit small and medium-scale, neighborhood-, community-, and region-serving commercial USES.
- c. To create DWELLING UNIT types, sizes, and BEDROOM counts ideal for larger households in apartment buildings.
- d. To create DWELLING UNIT types, sizes, and BEDROOM counts ideal for smaller households in general buildings.
- e. To permit increased residential density for buildings that are sustainable or that provide 100% AFFORDABLE HOUSING.
- f. To permit increased residential density for buildings that meet the definition of a NET ZERO BUILDING or 100% AFFORDABLE HOUSING.

#### 4. Applicability

- a. The section is applicable to all real property within the HIGH-RISE district as shown on the maps of the Official Zoning Atlas of the City of Somerville.

#### 5. Development Review

- a. DEVELOPMENT review is subject to the provisions of Article 15: Administration of this Ordinance.
- b. All DEVELOPMENT, excluding NORMAL MAINTENANCE, requires the submittal of a development review application to the BUILDING OFFICIAL and the issuance of a Certificate of Zoning Compliance prior to the issuance of a BUILDING Permit or Certificate of Occupancy.
- c. Proposed DEVELOPMENT may or may not necessitate the need for SUBDIVISION Plan Approval, Site Plan Approval, a Special Permit, or a Hardship Variance based on the nature of the proposal. In such cases, additional DEVELOPMENT review is required in accordance with Article 15: Administration.
  - i. The Planning Board is the decision making authority for all DEVELOPMENT that requires Site Plan Approval or a Special Permit.
  - ii. The Zoning Board of Appeals is the Review Board for all HARDSHIP Variances.
- d. Upon verification that no additional DEVELOPMENT review is necessary, or completion of the required DEVELOPMENT review, the BUILDING OFFICIAL shall issue a Zoning Compliance CERTIFICATE to certify compliance with the

provisions and procedures of this Ordinance.

#### 6. Building Types

- a. One (1) PRINCIPAL BUILDING TYPE is permitted on each LOT.
- b. The following BUILDING TYPES are permitted by Site Plan Approval in the HIGH-RISE district:
  - i. General BUILDING
  - ii. Commercial BUILDING
  - iii. Lab BUILDING
  - iv. Mid-Rise Podium Tower
  - v. BLOCK BUILDING
- c. Apartment Buildings are prohibited on any LOT fronting a PEDESTRIAN STREET.
- d. ACCESSORY STRUCTURES are regulated according to Article 10.0 DEVELOPMENT Standards of this Ordinance.



5.1.7 General Building

A large FLOOR PLATE, multi-STORY PRINCIPAL BUILDING TYPE with GROUND STORY commercial space and no limitations on the occupancy of UPPER STORIES for permitted USES. The UPPER STORIES of a general BUILDING are typically residential, but a wide variety exists. As the number of stories increases, it becomes more likely for the UPPER STORIES of a general BUILDING to host commercial USES as well as residential.

The following images are examples of the general BUILDING TYPE and are intended only for illustrative purposes.



# 5. HIGH-RISE DISTRICTS

High-Rise (HR)

## 5.1.7. General Building (continued)

### a. Lot Standards

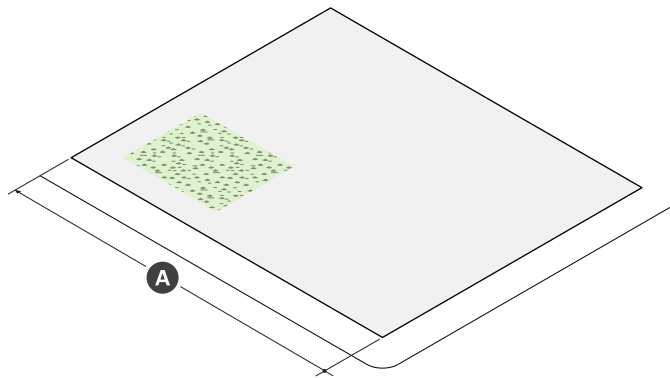

Lot Dimensions	
<b>A</b> LOT WIDTH (min)	30 ft

Lot Development	
LOT Coverage (max)	100%
GREEN SCORE	--
Minimum	0.20
Ideal	0.25
<b>B</b> OPEN SPACE (min)	15%

### b. BUILDING Placement

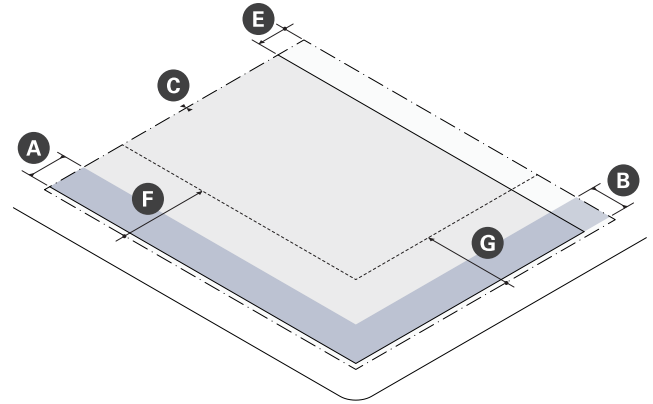

Building Setbacks		
<b>A</b> Primary Front SETBACK (min/max)	2 ft	15 ft
<b>B</b> Secondary Front SETBACK (min/max)	2 ft	15 ft
<b>C</b> Side SETBACK (min)	0 ft	
Side SETBACK ABUTTING NR or LHD (min)	10 ft	
<b>D</b> Rear SETBACK (min)	--	
ALLEY	0 ft	
No ALLEY	10 ft	
No ALLEY & ABUTTING NR or LHD	15 ft	

Parking Setbacks	
<b>E</b> Primary Front SETBACK (min)	30 ft
<b>F</b> Secondary Front SETBACK (min)	30 ft



## 5.1.7. General Building (continued)

### c. Massing & Height

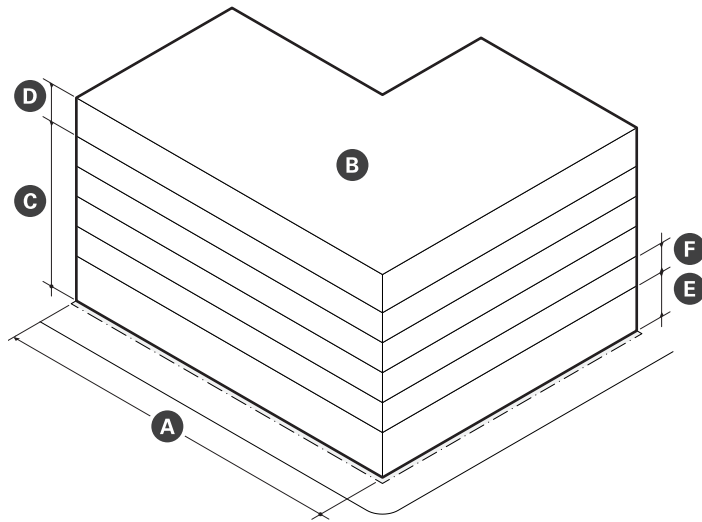

Main Massing	
<b>A</b> BUILDING WIDTH (max)	200 ft
FACADE Build Out (min)	–
Primary Front	80%
Secondary Front	65%
<b>B</b> FLOOR PLATE (max)	30,000 sf
<b>C</b> GROUND STORY Height (min)	14 ft
<b>D</b> UPPER STORY Height (min)	10 ft
<b>E</b> Number of Stories (min/max)	3   6
<b>F</b> BUILDING Height, Feet (max)	80 ft
Roof Type	Flat

### d. Uses & Features

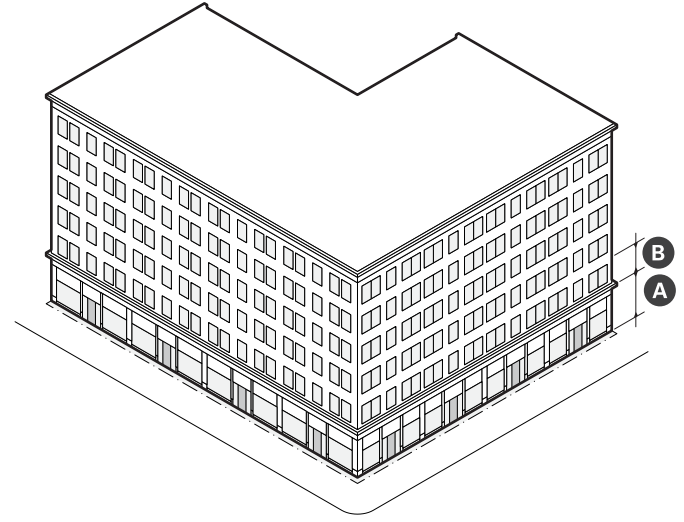

Facade Composition	
<b>A</b> GROUND STORY FENESTRATION (min)	70%
<b>B</b> UPPER STORY FENESTRATION (min/max)	20%   50%
BLANK WALL (max)	20 ft

Use & Occupancy	
GROUND STORY Entrance Spacing (max)	30 ft
Commercial Space Depth (min)	30 ft
GROSS FLOOR AREA per DU (min)	–
LOT AREA < 7,000 sf	1,125
LOT AREA >= 7,000 sf	875
NET ZERO BUILDING	650
100% AFFORDABLE HOUSING	650
Outdoor AMENITY SPACE (min)	1/DU

# 5. HIGH-RISE DISTRICTS

High-Rise (HR)

## 5.1.7. General Building (continued)

- e. DEVELOPMENT Benefits
  - i. DEVELOPMENT is subject to the provisions of Article 12: DEVELOPMENT Benefits of this Ordinance. Where the provisions of this section conflict with those of Article 12, the provisions of Article 12 apply.
  - ii. DEVELOPMENT of a general building must provide AFFORDABLE DWELLING UNITS as specified on Table 5.1.7 (a).
  - iii. DEVELOPMENT of a general building must provide linkage payments as specified on Table 5.1.7 (b).
- f. Design Guidelines
  - i. FENESTRATION patterns and window configurations should break the direct line of sight between neighboring properties to every extent practicable. Translucent glass on the bottom half of windows or strategically placed landscape elements should be utilized if it is not practical to off-set windows in such a way as to minimize privacy impacts.
  - ii. Outdoor AMENITY SPACES that are elevated, such as roof DECKS, fully projecting balconies, and UPPER STORY rear porches should,, provide sight-obscuring visual screening at the sides to increase privacy, security, and to limit views of ABUTTING properties from elevated vantage points.

**Table 5.1.7 (a) Required ADUs**

Total DWELLING UNITS	Required ADUs
0 to 5 units	None
6 units	1 unit OR fractional buyout for 0.4 units
7 units	1 unit OR fractional buyout for 0.6 units
8 to 17 units	17.5% of units
18 or more units	20% of units

**Table 5.1.7 (b) Linkage**

Commercial GROSS FLOOR AREA	Affordable Housing Linkage	Employment Linkage
30,000 sf or less	None	None
Over 30,000 sf	\$10/sf	\$2.46/sf

## 5.1.8 Commercial Building

A large FLOOR PLATE, multi-STORY PRINCIPAL BUILDING TYPE purpose built for OCCUPATION by commercial uses on all stories. GROUND STORY commercial space is primarily occupied by commercial service, food & beverage service, or retail sales PRINCIPAL USES. Floor space on upper stories may be occupied by retail uses that do not rely on the visibility of a storefront at sidewalk level.

The following images are examples of the commercial BUILDING TYPE and are intended only for illustrative purposes.



# 5. HIGH-RISE DISTRICTS

High-Rise (HR)

## 5.1.8. Commercial Building (continued)

a. Lot Standards

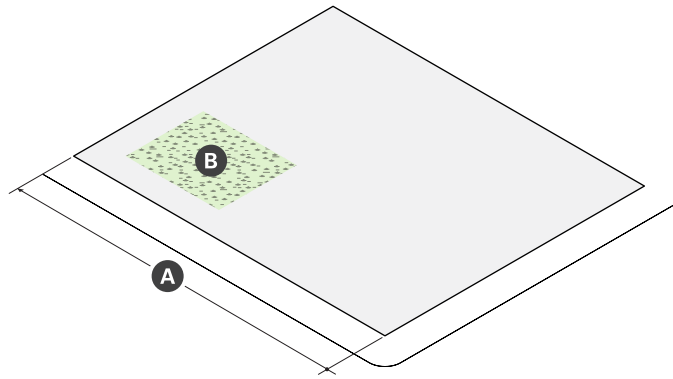

Lot Dimensions	
<b>A</b> Lot WIDTH (min)	30 ft

Lot Development	
Lot Coverage (max)	100%
GREEN SCORE	--
Minimum	0.20
Ideal	0.25
<b>B</b> OPEN SPACE (min)	15%

b. BUILDING Placement

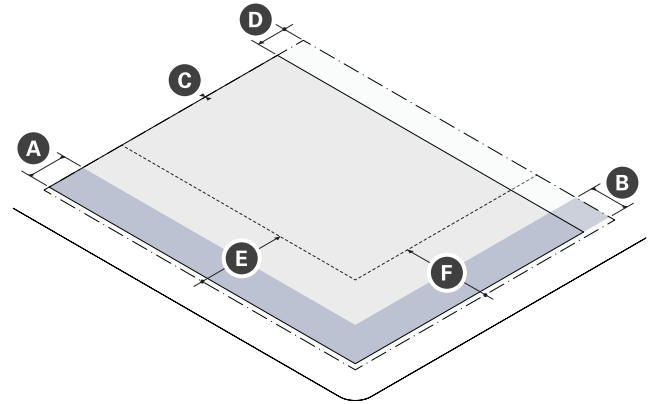

Building Setbacks		
<b>A</b> Primary Front SETBACK (min/max)	2 ft	15 ft
<b>B</b> Secondary Front SETBACK (min/max)	2 ft	15 ft
<b>C</b> Side SETBACK (min)	0 ft	
Side SETBACK ABUTTING NR or LHD (min)	10 ft	
<b>D</b> Rear SETBACK (min)	--	
ALLEY	0 ft	
No ALLEY	10 ft	
No ALLEY & ABUTTING NR or LHD	15 ft	

Parking Setbacks	
<b>E</b> Primary Front SETBACK (min)	30 ft
<b>F</b> Secondary Front SETBACK (min)	30 ft

## 5.1.8. Commercial Building (continued)

### c. Massing & Height

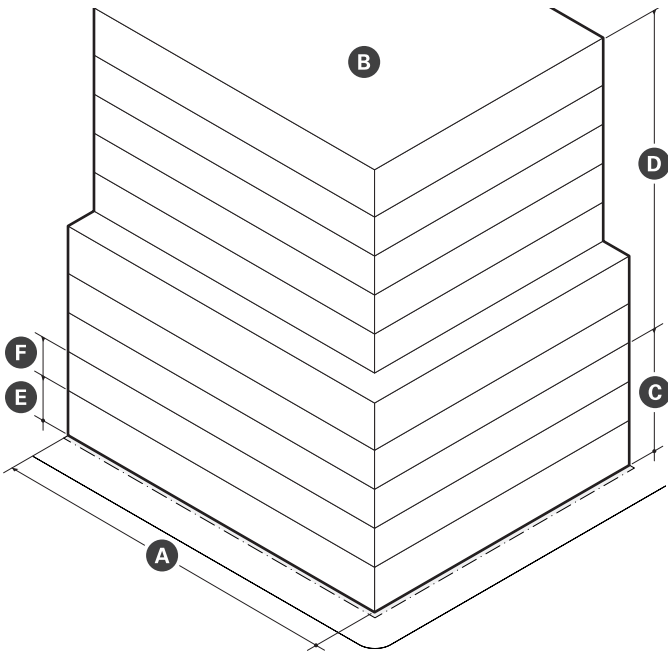

### d. Uses & Features

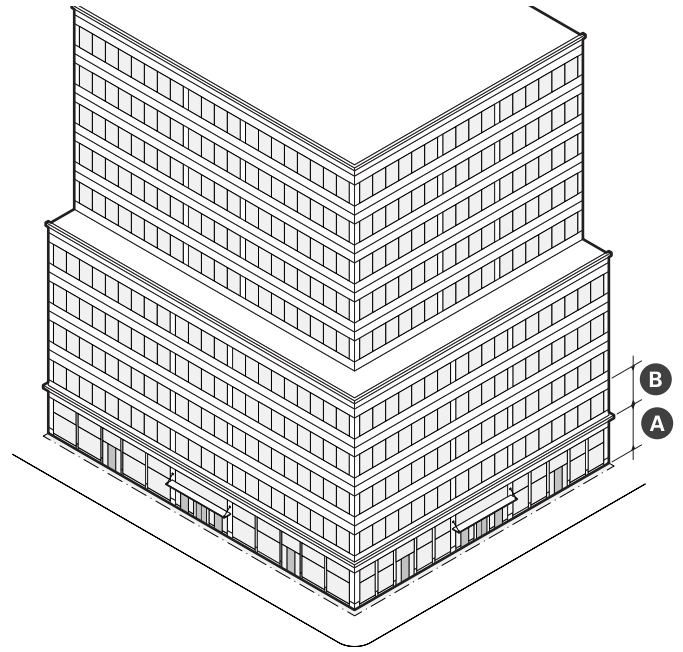

Main Massing	
<b>A</b> BUILDING WIDTH (max)	200 ft
FACADE Build Out (min)	–
Primary Front	80%
Secondary Front	65%
<b>B</b> FLOOR PLATE (max)	30,000 sf
<b>C</b> GROUND STORY Height (min)	14 ft
<b>D</b> UPPER STORY Height (min)	10 ft
<b>E</b> BUILDING Height, Stories (min/max)	3   10
<b>F</b> BUILDING Height, Feet (max)	145 ft
Roof Type	Flat

Facade Composition	
<b>A</b> GROUND STORY FENESTRATION (min)	70%
<b>B</b> UPPER STORY FENESTRATION (min/max)	20%   70%
BLANK WALL (max)	20 ft

Use & Occupancy	
Entrance Spacing (max)	30 ft
Commercial Space Depth (min)	30 ft



# 5. HIGH-RISE DISTRICTS

High-Rise (HR)

## 5.1.8. Commercial Building (continued)

- e. DEVELOPMENT Benefits
  - i. DEVELOPMENT is subject to the provisions of Article 12: DEVELOPMENT Benefits of this Ordinance. Where the provisions of this section conflict with those of Article 12, the provisions of Article 12 apply.
  - ii. DEVELOPMENT of a general building must provide linkage payments as specified on Table 5.1.8.

**Table 5.1.8 Linkage**

<b>Commercial GROSS FLOOR AREA</b>	<b>Affordable Housing Linkage</b>	<b>Employment Linkage</b>
30,000 sf or less	None	None
Over 30,000 sf	\$10/sf	\$2.46/sf



## 5.1.9 Lab Building

A large FLOOR PLATE, multi-STORY PRINCIPAL BUILDING TYPE purpose built for occupation by laboratory and research & DEVELOPMENT PRINCIPAL USES. Floor space is typically custom designed as complex, technically sophisticated, and mechanically intensive wet or dry labs or vivariums for animal research.

The following images are examples of the lab BUILDING TYPE and are intended only for illustrative purposes.



# 5. HIGH-RISE DISTRICTS

High-Rise (HR)

## 5.1.9. Lab Building (continued)

a. Lot Standards

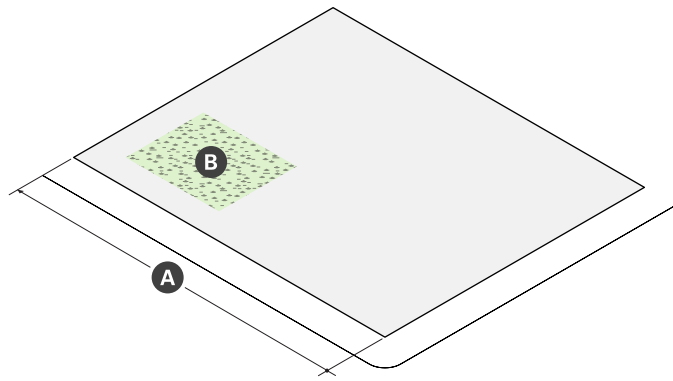

Lot Dimensions	
<b>A</b> Lot Width (min)	30 ft

Lot Coverage	
Lot Coverage (max)	100%
Green Score	--
Minimum	0.20
Ideal	0.25
<b>B</b> Open Space (min)	15%

b. Building Placement

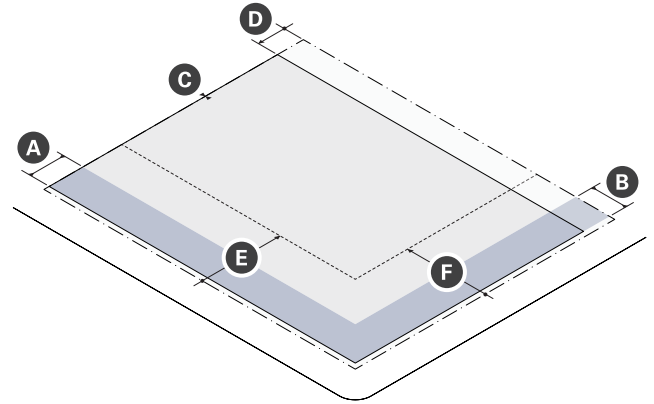

Building Setbacks		
<b>A</b> Primary Front SETBACK (min/max)	2 ft	15 ft
<b>B</b> Secondary Front SETBACK (min/max)	2 ft	15 ft
<b>C</b> Side SETBACK (min)	0 ft	
Side SETBACK ABUTTING NR or LHD (min)	10 ft	
<b>D</b> Rear SETBACK (min)	--	
ALLEY	0 ft	
No ALLEY	10 ft	
No ALLEY & ABUTTING NR or LHD	15 ft	

Parking Setbacks	
<b>E</b> Primary Front SETBACK (min)	30 ft
<b>F</b> Secondary Front SETBACK (min)	30 ft

## 5.1.9. Lab Building (continued)

### c. Massing & Height

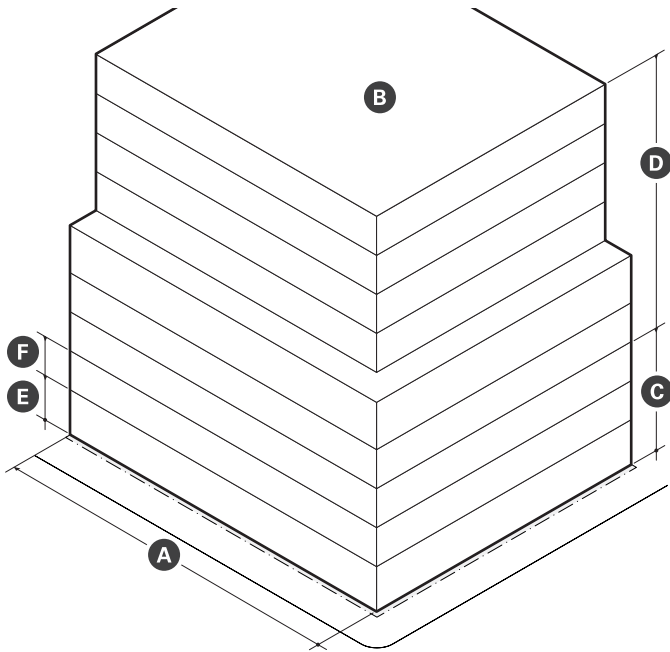

### d. Uses & Features

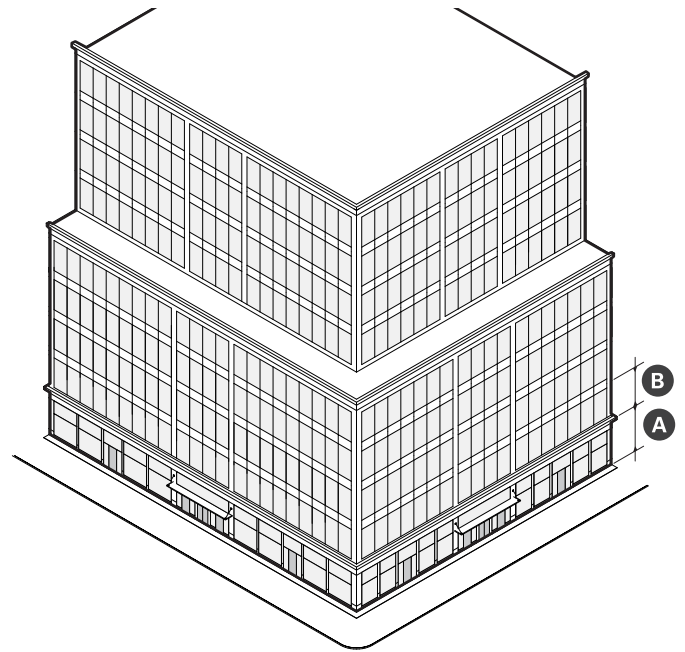

#### Main Massing

<b>A</b> Width (max)	240 ft
FACADE Build Out (min)	--
Primary Front	80%
Secondary Front	65%
<b>B</b> FLOOR PLATE	35,000 sf
<b>C</b> GROUND STORY Height	14 ft
<b>D</b> UPPER STORY Height	10 ft
<b>E</b> BUILDING Height, Stories (min/max)	4   9
<b>F</b> BUILDING Height, Feet (max)	145 ft
Roof Type	Flat

#### Facade Composition

<b>A</b> GROUND STORY FENESTRATION (min)	70%
<b>B</b> UPPER STORY FENESTRATION (min/max)	20%   70%
BLANK WALL (max)	20 ft

#### Use & Occupancy

Entrance Spacing (max)	30 ft
Commercial Space Depth (min)	30 ft

# 5. HIGH-RISE DISTRICTS

High-Rise (HR)

## 5.1.9. Lab Building (continued)

- e. DEVELOPMENT Benefits
  - i. DEVELOPMENT is subject to the provisions of Article 12: DEVELOPMENT Benefits of this Ordinance. Where the provisions of this section conflict with those of Article 12, the provisions of Article 12 apply.
  - ii. DEVELOPMENT of a general building must provide linkage payments as specified on Table 5.1.9.

**Table 5.1.9 Linkage**

<b>Commercial GROSS FLOOR AREA</b>	<b>Affordable Housing Linkage</b>	<b>Employment Linkage</b>
30,000 sf or less	None	None
Over 30,000 sf	\$10/sf	\$2.46/sf



## 5.1.10 Mid-Rise Podium Tower

A large FLOOR PLATE, multi STORY, PRINCIPAL BUILDING TYPE composed of a three (3) to six (6) STORY general BUILDING TYPE serving as a podium and an UPPER STORY residential POINT TOWER. The general building has ground story commercial space, spatially defines the PUBLIC REALM, and may incorporate STRUCTURED PARKING.

The following images are examples of the mid-rise podium tower BUILDING TYPE and are intended only for illustrative purposes.



# 5. HIGH-RISE DISTRICTS

High-Rise (HR)

## 5.1.10. Mid-Rise Podium Tower (continued)

a. Lot Standards

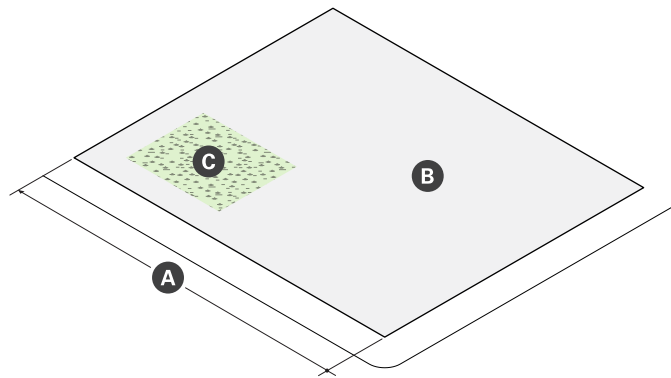

Lot Dimensions	
<b>A</b> LOT WIDTH (min)	150 ft

Lot Development	
LOT Coverage (max)	100%
GREEN SCORE	--
Minimum	0.20
Ideal	0.25
<b>B</b> OPEN SPACE (min)	15%

b. BUILDING Placement

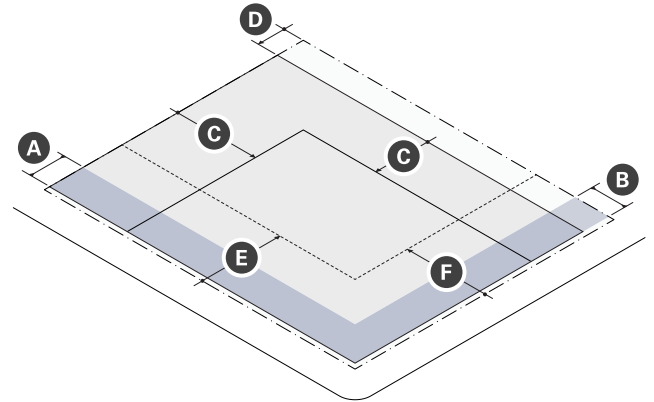

Building Setbacks		
<b>A</b> Primary Front SETBACK (min/max)	2 ft	15 ft
<b>B</b> Secondary Front SETBACK	2 ft	15 ft
<b>C</b> Side SETBACK (min)	--	
PODIUM	0 ft	
PODIUM ABUTTING NR or LHD	10 ft	
POINT TOWER	30 ft	
POINT TOWER ABUTTING NR or LHD	60 ft	
<b>D</b> PODIUM Rear SETBACK (min)	--	
ALLEY	0 ft	
No ALLEY	10 ft	
No ALLEY & ABUTTING NR or LHD	15 ft	
POINT TOWER REAR SETBACK	30 ft	
ABUTTING NR or LHD	60 ft	

Parking Setbacks	
<b>E</b> Primary Front SETBACK (min)	30 ft
<b>F</b> Secondary Front SETBACK (min)	30 ft



## 5.1.10. Mid-Rise Podium Tower (continued)

### c. Massing & Height

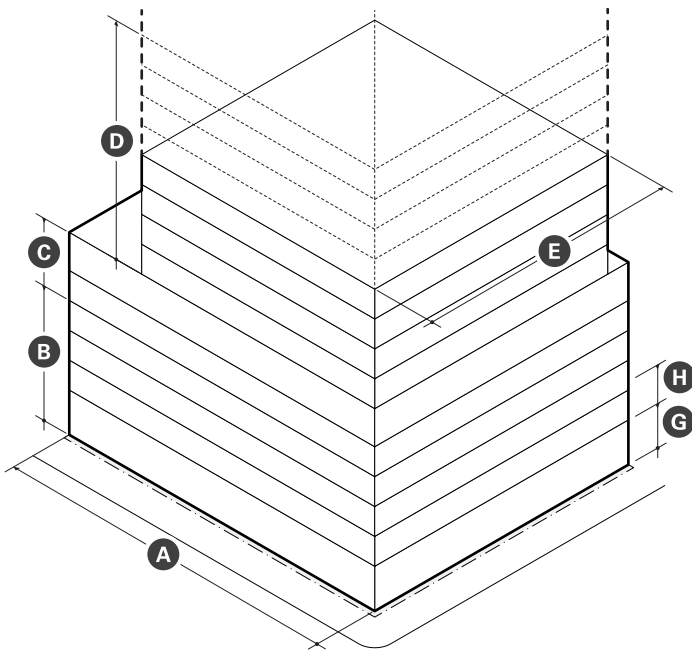

### d. Uses & Features

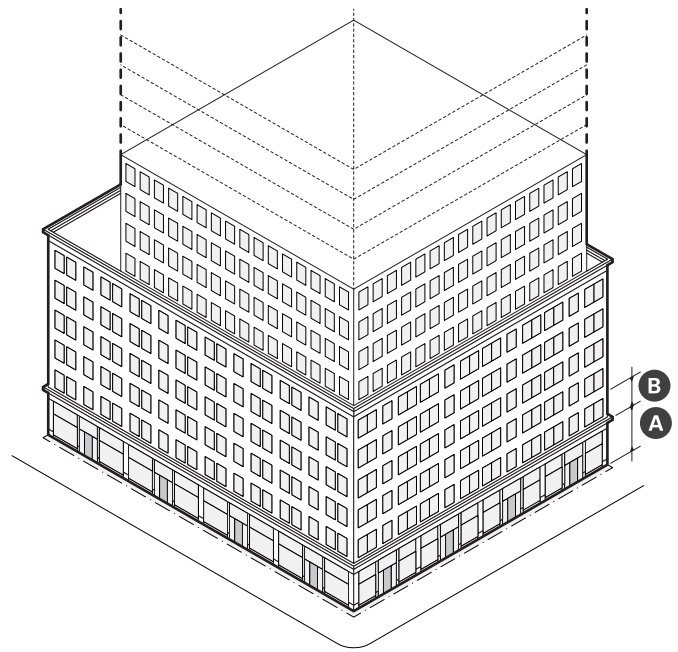

Main Massing	
<b>A</b> Width (max)	250 ft
FAÇADE Build Out (min)	80%
FLOOR PLATE (max)	--
PODIUM	35,000 sf
POINT TOWER	10,000 sf
<b>B</b> GROUND STORY Height (min)	14 ft
<b>C</b> UPPER STORY Height (min)	10 ft
<b>D</b> Number of Stories (min)	4
Number of Stories (max)	--
<b>E</b> PODIUM	6
<b>F</b> POINT TOWER	18
POINT TOWER Dimensions (max)	--
<b>G</b> Width & Depth	100 ft
Diagonal	145 ft
BUILDING Height, Feet (max)	--
PODIUM	80 ft
POINT TOWER	275 ft
Roof Type	Flat

Facade Composition	
<b>A</b> GROUND STORY FENESTRATION (min)	70%
<b>B</b> UPPER STORY FENESTRATION (min/max)	20% 50%
BLANK WALL (max)	20 ft

Use & Occupancy	
Entrance Spacing (max)	30 ft
Commercial Space Depth (min)	30 ft
GROSS FLOOR AREA per DU	--
LOT AREA < 7,000 sf	1,125
LOT AREA >= 7,000 sf	875
NET ZERO BUILDING	650
100% AFFORDABLE HOUSING	650
Outdoor AMENITY SPACE (min)	1/DU

# 5. HIGH-RISE DISTRICTS

High-Rise (HR)

## 5.1.10. Mid-Rise Podium Tower (continued)

- e. DEVELOPMENT Benefits
  - i. DEVELOPMENT is subject to the provisions of Article 12: DEVELOPMENT Benefits of this Ordinance. Where the provisions of this section conflict with those of Article 12, the provisions of Article 12 apply.
  - ii. DEVELOPMENT of a general building must provide AFFORDABLE DWELLING UNITS as specified on Table 5.1.10 (a).
  - iii. DEVELOPMENT of a general building must provide linkage payments as specified on Table 5.1.10 (b).
- f. Design Standards
  - i. The top of the general building facade must include horizontal ARTICULATION such as a CORNICE or other molding or the POINT TOWER must be stepped back from the facade of the general building.
  - ii. The review boards may require the POINT TOWER to be stepped back from the stories below up to ten (10) feet as a condition of Site Plan Approval to emphasize the appearance of the PODIUM as a mid-rise building.
- g. Design Guidelines
  - i. FENESTRATION patterns and window configurations should break the direct line of sight between neighboring properties to every extent practicable. Translucent glass on the bottom half of windows or strategically placed landscape elements should be utilized if it is not practical to off-set windows in such a way as to minimize privacy impacts.
  - ii. Outdoor AMENITY SPACES that are elevated, such as

**Table 5.1.10 (a) Required ADUs**

Total DWELLING UNITS	Required ADUs
0 to 5 units	None
6 units	1 unit OR fractional buyout for 0.4 units
7 units	1 unit OR fractional buyout for 0.6 units
8 to 17 units	17.5% of units
18 or more units	20% of units

**Table 5.1.10 (b) Linkage**

Commercial GROSS FLOOR AREA	Affordable Housing Linkage	Employment Linkage
30,000 sf or less	None	None
Over 30,000 sf	\$10/sf	\$2.46/sf

roof DECKS, fully projecting balconies, and UPPER STORY rear porches should, provide sight-obscuring visual screening at the sides to increase privacy, security, and to limit views of ABUTTING properties from elevated vantage points.

**Figure 5.1.10 Podium Articulation Example**





## 5.1.11 Block Building

A very large FLOOR PLATE, multi-STORY, PRINCIPAL BUILDING TYPE composed of a three (3) to six (6) STORY PODIUM with GROUND STORY commercial space and one (1) or more UPPER STORY TOWERS. A BLOCK BUILDING occupies either an entire BLOCK or half of a BLOCK, on a LOT that fronts onto at least three (3) THOROUGHFARES or CIVIC SPACES. BLOCK buildings are designed to appear as an assembly of attached buildings, each with its own massing, proportions, and detailing.

The following images are examples of the BLOCK BUILDING TYPE and are intended only for illustrative purposes.



# 5. HIGH-RISE DISTRICTS

High-Rise (HR)

## 5.1.11. Block Building (continued)

a. Lot Standards

b. BUILDING Placement

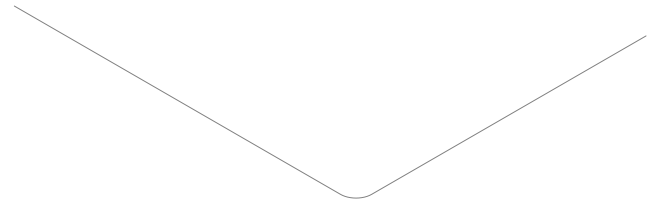
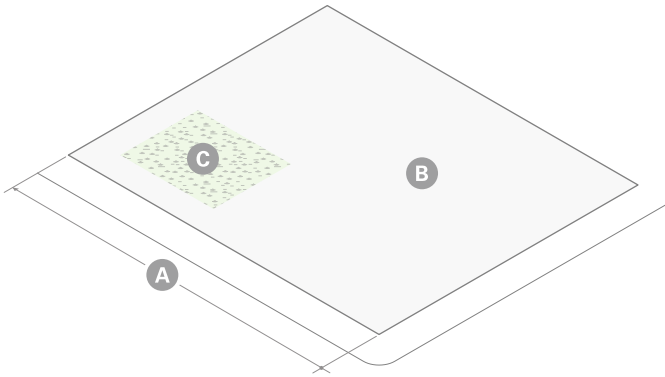

Lot Dimensions	
<b>A</b> Lot Width (min)	200 ft
Depth (min)	250 ft

Lot Development	
<b>B</b> Lot Coverage (max)	100%
GREEN SCORE	--
Minimum	0.20
Ideal	0.25
<b>C</b> OPEN SPACE (min)	15%

Building Setbacks		
<b>A</b> Primary Front SETBACK (min/max)	2 ft	15 ft
<b>B</b> Secondary Front SETBACK	2 ft	15 ft
<b>C</b> Side SETBACK (min)	--	
PODIUM	0 ft	
PODIUM ABUTTING NR or LHD	10 ft	
TOWER	30 ft	
TOWER ABUTTING NR or LHD	60 ft	
<b>D</b> PODIUM Rear SETBACK (min)	--	
ALLEY	0 ft	
No ALLEY	10 ft	
No ALLEY & ABUTTING NR or LHD	15 ft	
POINT TOWER REAR SETBACK	30 ft	
ABUTTING NR or LHD	60 ft	

Parking Setbacks	
<b>E</b> Primary Front SETBACK (min)	30 ft
<b>F</b> Secondary Front SETBACK (min)	30 ft

## 5.1.11. Block Building (continued)

c. Massing & Height

d. Uses & Features

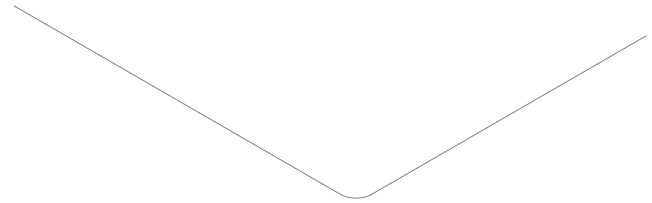
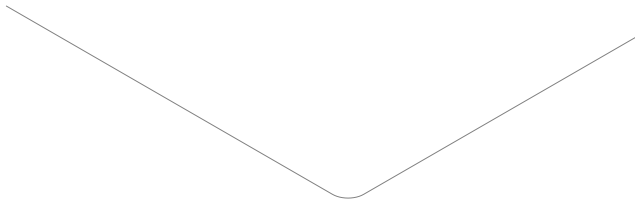

### Main Massing

<b>A</b>	BUILDING WIDTH (max)	500 ft
	FACADE Build Out (min)	--
	Primary Front	100%
	Secondary Front	100%
	FLOOR PLATE (max)	--
	PODIUM	n/a
	TOWER(S)	30,000 sf
<b>B</b>	GROUND STORY Height (min)	14 ft
<b>C</b>	UPPER STORY Height (min)	10 ft
<b>D</b>	Number of Stories (min)	3 stories
	Number of Stories (max)	--
<b>E</b>	PODIUM	6 stories
<b>F</b>	TOWER(S)	10 stories
<b>G</b>	Building Height (min)	10 ft
	PODIUM	80 ft
	TOWER(S)	145 ft
	Roof Type	Flat

### Facade Composition

<b>A</b>	GROUND STORY FENESTRATION (min)	70%
<b>B</b>	UPPER STORY FENESTRATION (min/max)	-- --
	Residential	20% 50%
	Commercial	20% 70%
	BLANK WALL (max)	20 ft

### Use & Occupancy

	GROUND STORY Entrance Spacing (max)	30 ft
	Commercial Space Depth (min)	30 ft
	GROSS FLOOR AREA per DU	--
	LOT AREA < 7,000 sf	1,125
	LOT AREA >= 7,000 sf	850
	NET ZERO BUILDING	650
	100% AFFORDABLE HOUSING	650
	Outdoor AMENITY SPACE (min)	1/DU



# 5. HIGH-RISE DISTRICTS

High-Rise (HR)

## 5.1.11. Block Building (continued)

- e. DEVELOPMENT Benefits
  - i. DEVELOPMENT is subject to the provisions of Article 12: DEVELOPMENT Benefits of this Ordinance. Where the provisions of this section conflict with those of Article 12, the provisions of Article 12 apply.
  - ii. DEVELOPMENT of a BLOCK building must provide AFFORDABLE DWELLING UNITS as specified on Table 5.1.11 (a).
  - iii. DEVELOPMENT of a BLOCK building must provide linkage payments as specified on Table 5.1.11 (b).
- f. Building Design Standards
  - i. The FACADE of any BLOCK building greater than two hundred (200) feet in width must be designed as two (2) or more separate and distinct facades of differing architectural design so that the building appears to be multiple buildings. The facade designs must include a change in CORNICE, roof eave, or parapet design from one another.
  - ii. One (1) GROUND STORY commercial space is required per seventy (70) feet of building width, including vehicular entrances, for each BLOCK FACE.
  - iii. One (1) lobby entrance is permitted per BLOCK FACE and each TOWER must have an individual lobby entrance serving the UPPER STORY USES.
- g. DEVELOPMENT Standards
  - i. Loading facilities and services areas must be located within the building and set back from any FACADE by at least thirty (30) feet. Transformer and fire suppression rooms are exempt.

**Table 5.1.11 (a) Required ADUs**

Total DWELLING UNITS	Required ADUs
0 to 5 units	None
6 units	1 unit OR fractional buyout for 0.4 units
7 units	1 unit OR fractional buyout for 0.6 units
8 to 17 units	17.5% of units
18 or more units	20% of units

**Table 5.1.11 (b) Linkage**

Commercial GROSS FLOOR AREA	Affordable Housing Linkage	Employment Linkage
30,000 sf or less	None	None
Over 30,000 sf	\$10/sf	\$2.46/sf

- h. Parking & Mobility
  - i. One (1) vehicular entrance is permitted per BLOCK FACE, but no more than two (2) vehicular entrances are permitted per BLOCK building.
- i. PUBLIC REALM
  - i. BLOCK buildings occupying an entire BLOCK must provide a covered ALLEY internal to the building.

**Figure 5.1.11 (a) Appearance of Two Buildings**





**12. Building Components**

- a. BUILDING COMPONENTS are ACCESSORY elements attached to the MAIN MASSING of a BUILDING.
- b. BUILDING COMPONENTS are permitted by Site Plan Approval as specified on Table 5.1.12.
  - i. At least one (1) storefront is required for each GROUND STORY commercial space.
- c. BUILDING COMPONENTS not identified on Table 5.1.12 are prohibited.
- d. Unless otherwise specified, BUILDING COMPONENTS may attach to other BUILDING COMPONENTS to create assemblies of components.

**Table 5.1.12 Building Components**

	General BUILDING	Commercial BUILDING	LAB BUILDING	Mid-Rise Podium Tower	Block BUILDING
Awning	P	P	P	P	P
Entry Canopy	P	P	P	P	P
Lobby Entrance	P	P	P	P	P
Storefront	P	P	P	P	P
Stoop	P	N	N	P	N
Bay Window	P	P	P	P	P
Balcony	P	N	N	P	P
Arcade	P	P	P	P	P

P - Permitted    SP - Special Permit Required    N - Not Permitted

# 5. HIGH-RISE DISTRICTS

High-Rise (HR)

## e. Awning

- i. An awning is a wall mounted frame covered with fabric or other material that provides shade and weather protection over a storefront or BUILDING entrance.

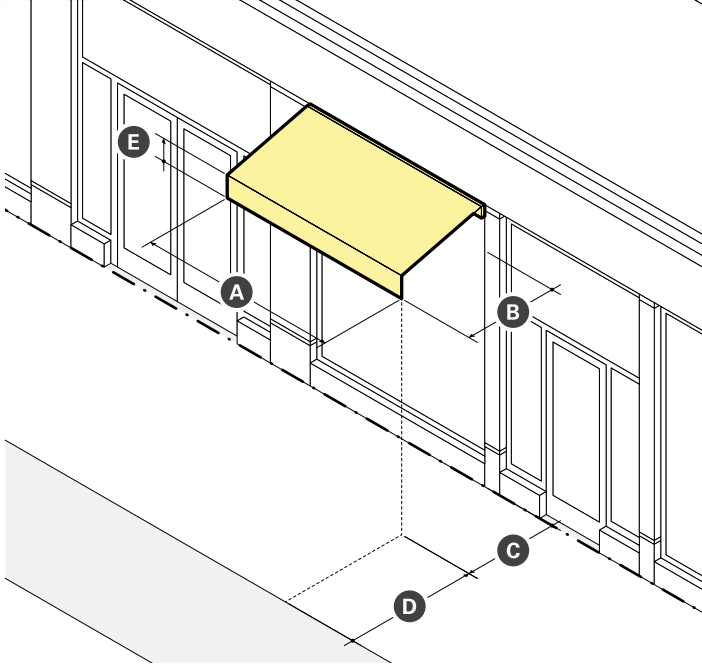

Dimensions	
<b>A</b> Width (min)	See ii Standards
<b>B</b> Projection (min)	3 ft
<b>C</b> CLEARANCE (min)	8 ft
Front SETBACK ENCROACHMENT (max)	100%
<b>D</b> SETBACK from Curb (min)	2 ft
<b>E</b> Valance Height (max)	12 in

- ii. Standards
  - a). Awnings must be securely attached to and supported by the BUILDING and must fit the windows or doors the awning is attached to.
  - b). An awning must be made of durable, weather-resistant material that is water repellent.
  - c). Internally illuminated or back-lit awnings are prohibited.
  - d). An awning that projects over the sidewalk of a public THOROUGHFARE requires compliance with all City Ordinances.

## f. Entry Canopy

- i. An entry canopy is a wall-mounted STRUCTURE that provides shade and weather protection over a storefront or BUILDING entrance.

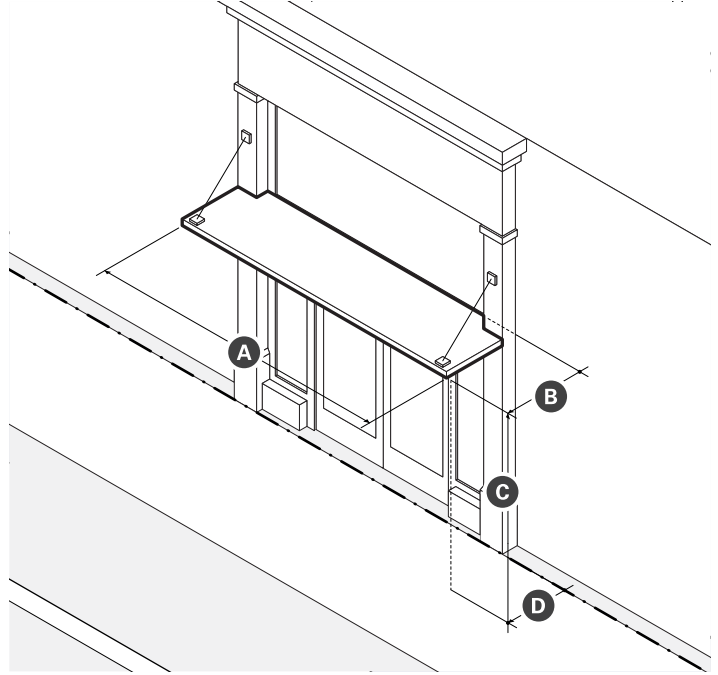

Dimensions	
<b>A</b> Width (min)	See ii Standards
<b>B</b> Projection (min)	3 ft
<b>C</b> CLEARANCE (min)	8 ft
<b>D</b> Front SETBACK ENCROACHMENT (max)	100%
SETBACK from Curb (min)	2 ft

- ii. Standards
  - a). Entry canopies must be visually supported by brackets, cables, or rods.
  - b). The width of an entry canopy must be equal to or greater than the width of the doorway surround or exterior casing it is mounted over.

## g. Lobby Entrance

- i. A lobby entrance is a non-load bearing assembly of entry doors and windows providing ACCESS and light to the lobby of a BUILDING.

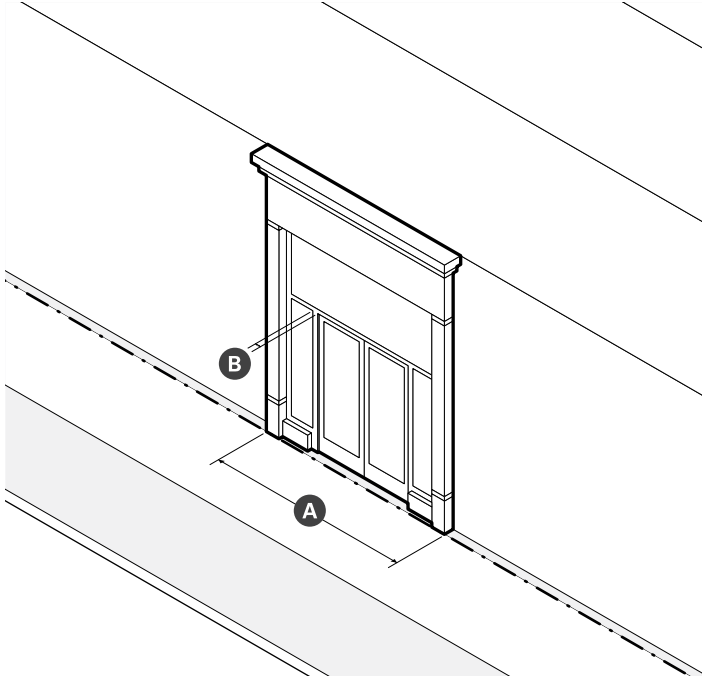

Dimensions		
<b>A</b> Width (min/max)	15 ft	30 ft
<b>B</b> Height (min)	80% of GROUND STORY Height	
Recessed Entrance Width (max)	15 ft	
Recessed Entrance Depth (max)	5 ft	

- ii. Standards
  - a). When a lobby entrance is set back from the FRONT LOT LINE, the FRONTAGE AREA must be paved.

## h. Storefront

- i. A storefront is a non-load bearing assembly of commercial entry doors and windows providing ACCESS and light to a commercial space and a place to display goods, services, and SIGNS.

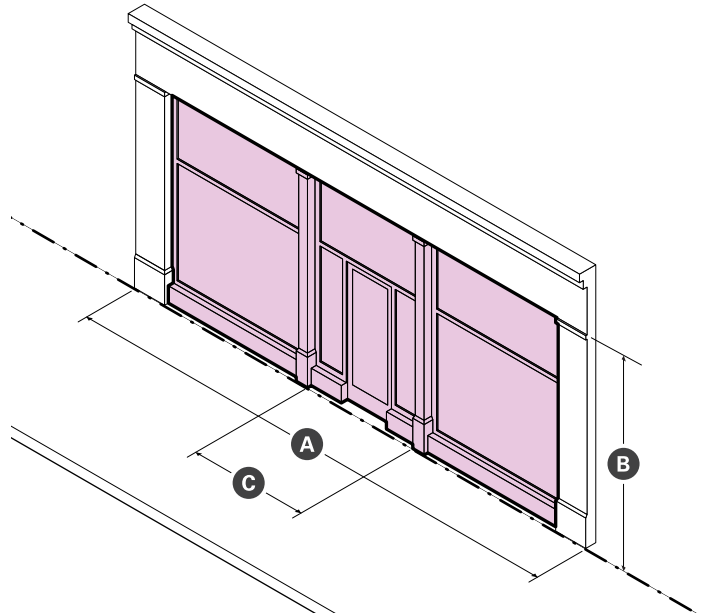

Dimensions		
<b>A</b> Width (min/max)	15 ft	30 ft
<b>B</b> Height (min)	80% of GROUND STORY Height	
Display Window Height (min)	8 ft	
Recessed Entrance Width (max)	15 ft	
Recessed Entrance Depth (max)	5 ft	

- ii. Standards
  - a). An unobstructed view of the interior space or a lighted and maintained merchandise display(s) must be provided for a depth of at least four (4) feet behind storefront display windows.
  - b). When storefronts are set back from the FRONT LOT LINE, the FRONTAGE AREA must be paved.
  - c). When present, awnings and canopies must be mounted between columns, PILASTERS, OR PIERS; above doorways and display windows; and below the SIGN BAND.
  - d). Exterior security grilles, gates, and roll-down security doors and windows are prohibited.

# 5. HIGH-RISE DISTRICTS

High-Rise (HR)

## i. Stoop

- i. A stoop is a set of stairs with a landing leading to the entrance of a BUILDING.

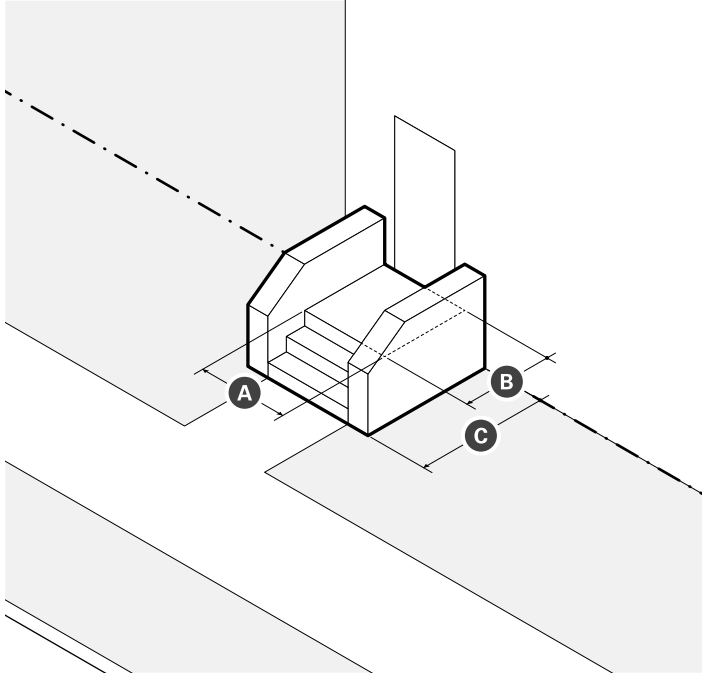

Dimensions	
<b>A</b> Landing Width (min)	4 ft
<b>B</b> Landing Depth (min)	4 ft
<b>C</b> Front SETBACK ENCROACHMENT (max)	100%

- ii. Standards
  - a). Paving, excluding driveways, must match the ABUTTING sidewalk unless paved with pervious, porous, or permeable materials.
  - b). Stairs may be recessed into the BUILDING FACADE when the BUILDING is set back four (4) feet or less.
  - c). Stairs are not permitted to ENCROACH onto any ABUTTING sidewalk.
  - d). Stairs may be built perpendicular or parallel to the BUILDING FACADE, but must lead directly to ground level or an ABUTTING sidewalk.

## j. Bay Window

- i. A bay window is an assembly of windows projecting from a building to provide additional HABITABLE space, increased light, multi-directional views, and ARTICULATION to an exterior wall.

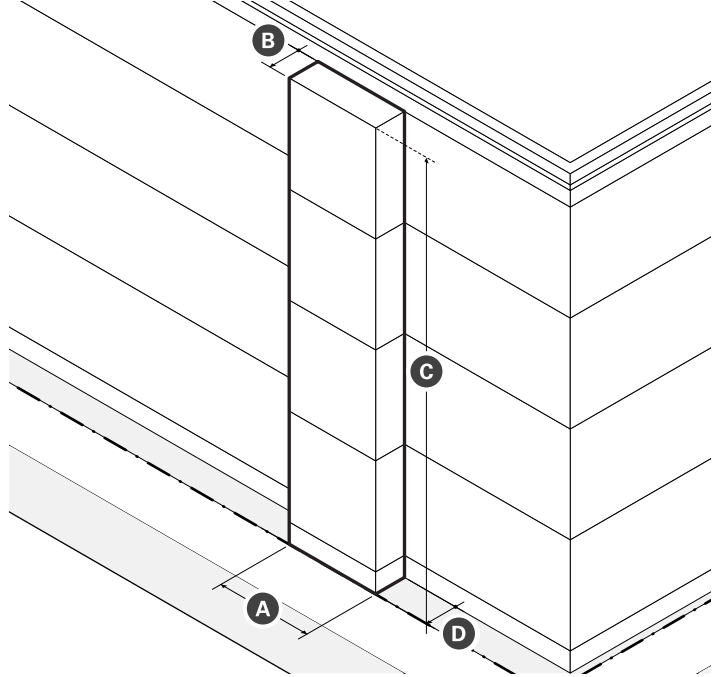

Dimensions	
<b>A</b> Width (max)	16 ft
<b>B</b> Projection (max)	3 ft
<b>C</b> Height (max)	Height of BUILDING in Stories
<b>D</b> Front SETBACK ENCROACHMENT (max)	3 ft
FENESTRATION (min)	60%

- ii. Standards
  - a). Bay windows, including box and bow windows, must include at least three (3) windows.
  - b). The cumulative width of multiple bays may equal up to fifty percent (50%) of the width of the exterior wall from which the bays project.
  - c). Bays projecting over the sidewalk of a public THOROUGHFARE must have at least two (2) stories of CLEARANCE and be compliant with all City Ordinances.

## k. Balcony

- i. A balcony is a platform with a railing that provides outdoor AMENITY SPACE.

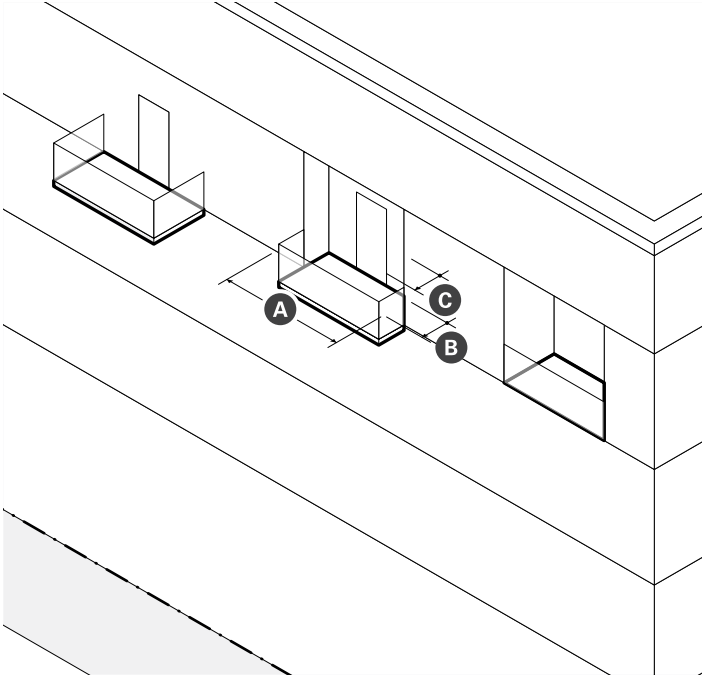

Dimensions	
<b>A</b> Width (min)	5 ft
<b>B</b> Depth (max)	5 ft
<b>D</b> Area (min)	50 ft
CLEARANCE (min)	10 ft
Permitted Front SETBACK ENCROACHMENT (max)	6 ft

- ii. Standards
  - a). Balconies may be recessed, projecting, a combination of the two, or terraced as part of the roof of a portico, porch, or bay.
  - b). A balcony that projects over the sidewalk of a public THOROUGHFARE requires compliance with all City Ordinances.
  - c). The guard rail of any balcony oriented toward a FRONT LOT LINE must permit visual supervision of the PUBLIC REALM through the posts and rails.
  - d). The guard rail of any balcony oriented toward a side OF REAR LOT LINE ABUTTING the NR district must include sight-obscuring visual screening so that it is at least fifty percent (50%) opaque.

## l. Arcade

- i. An arcade is a pedestrian walkway covered by the upper floors of a BUILDING. The GROUND STORY FACADE is SETBACK and upper floors are supported by a colonnade or supports.

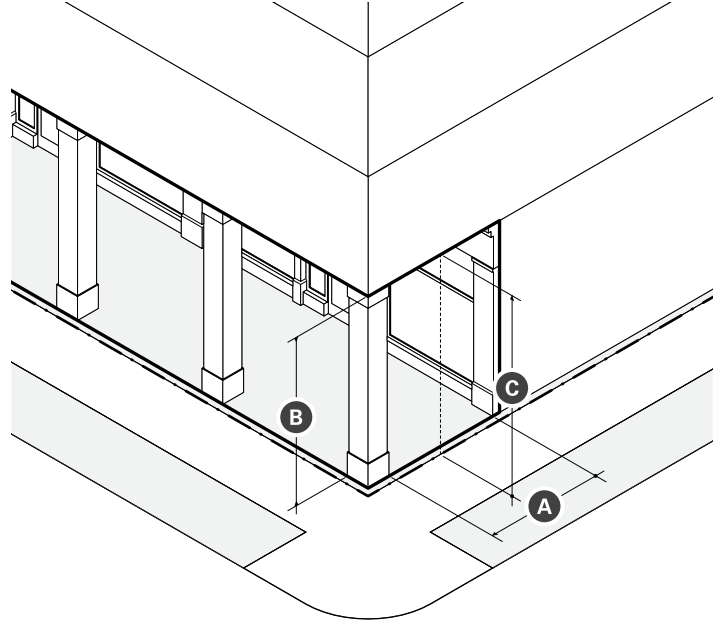

Dimensions		
<b>A</b> Depth (min/max)	10 ft	15 ft
<b>B</b> Height (max)	1 STORY	
<b>C</b> CLEARANCE (min/max)	14 ft	24 ft

- ii. Standards
  - a). Arcades must extend the entire width of a BUILDING and must have a consistent depth.
  - b). Support columns or PIERS may be spaced no farther apart than they are tall.
  - c). Arcades are considered part of the BUILDING for the purpose of measuring FACADE build out.
  - d). Arcades may be combined only with storefront and lobby entrance frontages.
  - e). The finished ceiling of an arcade interior may be arched or flat, but must have a greater CLEARANCE than the openings between columns OR PIERS.

# 5. HIGH-RISE DISTRICTS

High-Rise (HR)

## 13. Facade Design

- a. FACADES must provide solid material framing each storefront and lobby entrance as follows:
  - i. PILASTERS or columns supporting a horizontal lintel and CORNICE;
  - ii. a spandrel positioned between PILASTERS or columns that extend from upper stories of the building to the ground; or
  - iii. flat wall above and to either side of a void or punched opening.
- b. Storefronts and lobby entrances must be set within the resulting frame provided for each by the FACADE.
- c. Materials framing each storefront or lobby entrance may be integrated into the design of the FACADE or customized for individual storefronts and lobby entrances. Mechanical louvers necessary for venting purposes are not permitted in the required frame, but may be incorporated into any storefront or lobby entrance system.
- d. FACADES must differentiate the GROUND STORY of the building from the upper stories through horizontal ARTICULATION, a change in material, or a change window size or pattern to create a distinct base to the building FACADE. The entire height of the GROUND STORY must be included in the FACADE base.
- e. The FACADE of buildings with five (5) or more stories should include, at least, the entire height of the first two (2) stories in the design of the required base. The design of the base may not shift up or down across the width of the FACADE.

- f. For buildings with more than one FACADE, the design of the base must align horizontally at the corner.
- g. FACADES must provide surface relief from the average plane of the FACADE by at least four (4) inches, through the USE of architectural elements such as bay windows, columns, CORNER BOARDS, CORNICES, door and window surrounds, moldings, PIERS, PILASTERS, recessed storefronts or lobby entrances, seat walls, sills, wall depth, and recessed or projecting windows.

## 14. Architectural Design Guidelines

- i. FACADES should be visually divided into a series of ARCHITECTURAL BAYS that are derived, in general, from the building's structural bay spacing.
- ii. PIERS, PILASTERS, or other features defining each ARCHITECTURAL BAY should either extend all the way to the ground or terminate at any horizontal ARTICULATION defining the base of the building.
- iii. ARCHITECTURAL BAYS should align, in general, with individual or groups of storefronts and lobby entrances.
- iv. PIERS, PILASTERS, or other features defining each ARCHITECTURAL BAY should always project forward and be uninterrupted by any horizontal articulation, excluding any horizontal ARTICULATION USED to differentiate the base of the building.
- v. The FACADE of buildings with five (5) or more stories should be visually divided into, at least, a horizontal tripartite division (a base, middle, and top). The horizontal divisions may not shift up or down

**Figure 5.1.13 Storefront Framing**

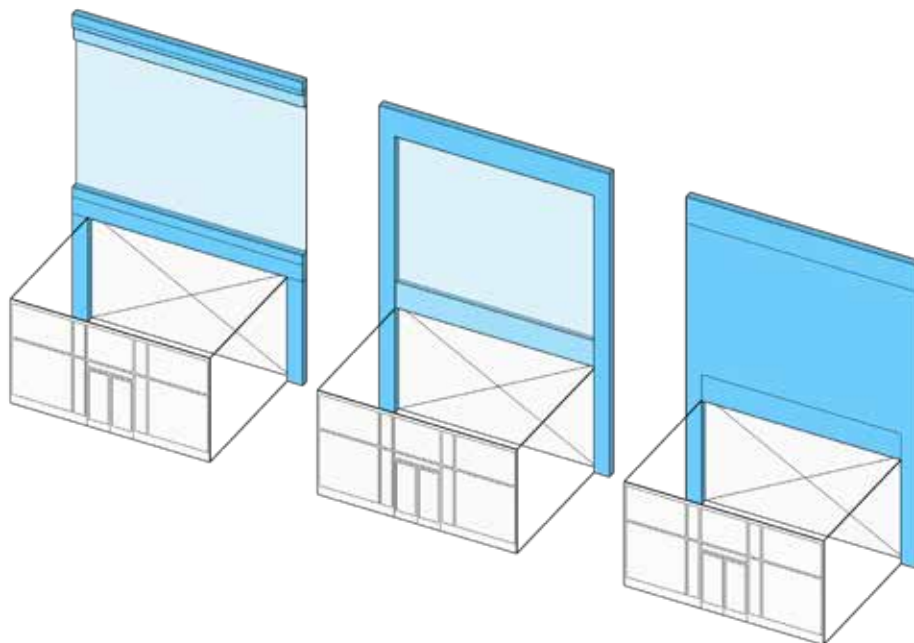



- across the width of the FACADE.
- vi. Vents, exhausts, and other utility features on building FACADES should be architecturally integrated into the design of the building and should be located to minimize adverse effects on pedestrian comfort along sidewalks and within OPEN SPACES.
- vii. Buildings at TERMINATED VISTAS should be ARTICULATED with design features that function as focal points.
- viii. FENESTRATION glazing should be inset from the plane of exterior wall surfaces.
- ix. RIBBON WINDOWS should be avoided.
- x. Monotonous and repetitive storefront or lobby systems, awnings, canopies, SIGN types, colors, or designs should be avoided.
- xi. Storefronts and lobby entrances should include awnings or canopies to provide weather protection for pedestrians and reduce glare for storefront display areas. Awnings should be open-ended and operable.
- xii. Lobby entrances for UPPER STORY USES should be optimally located, well defined, clearly visible, and separate from the entrance for other GROUND STORY USES.
- xiii. Lobbies should be limited in both width and total area to preserve floor space and frontage for other GROUND STORY USES. Buildings should USE any combination of FACADE ARTICULATION, a double-height ceiling, a distinctive doorway, a change in wall material, a change in paving material within the FRONTAGE AREA, or some other architectural element(s) to make lobbies visual and materially distinctive.
- a. Materials
  - i. The selection of materials, FENESTRATION, and ornamentation should result in a consistent and harmonious composition that appears as a unified whole rather than a collection of unrelated parts, no matter the style.
  - ii. The type and color of materials should be kept to a minimum, preferably three (3) or fewer.
  - iii. Two (2) or more wall materials should be combined only one above the other, except for bay windows.
  - iv. Wall materials appearing heavier in weight should be USED below wall materials appearing lighter in weight (wood and metal above brick, and all three above stone)
  - v. Horizontal or vertical board siding or shingles, regardless of material, should be avoided.
  - vi. Architectural details and finish materials for the base of a building should be constructed of architectural concrete or pre-cast cementitious panels, natural or cast stone, heavy gauge metal panels, glazed or unglazed architectural terracotta, or brick.
  - vii. Exterior Insulation and Finish Systems (EIFS) should be avoided.

# 5. HIGH-RISE DISTRICTS

High-Rise (HR)

## 15. Use Provisions

- a. Permitted Uses
  - i. The USE of real property is subject to the provisions of Article 9: USE Provisions of this Ordinance. Where the provisions of this section conflict with those of Article 9, the provisions of Article 9 apply.
  - ii. USE categories are permitted as specified on Table 5.1.15. USE categories not identified on Table 5.1.15 are prohibited.
  - iii. All USES must comply with any USE-specific standards applicable for each USE in §9.2 USE Definitions & Limitations.
  - iv. USES permitted by Special Permit require additional DEVELOPMENT review in accordance with §15.2.1 Special Permits.
- b. USE Limitations
  - i. The USE of any GROUND STORY commercial space fronting a PEDESTRIAN STREET, excluding lobbies for UPPER STORY USES, is limited to the following PRINCIPAL USE categories:
    - a). Arts & Creative Enterprise
    - b). Food & Beverage Service
    - c). Retail Sales
    - d). Civic & Institutional
- c. Required USES
  - i. A minimum of five percent (5%) of the gross leasable commercial floor space in any BUILDING must be provided as LEASABLE FLOOR AREA for USES from the Arts & Creative Enterprise USE category.

**Table 5.1.15 Permitted Uses**

Use Category Specific Use	HR
<b>Arts &amp; Creative Enterprise</b>	
Artisinal Production	P
Arts Exhibition	P
Arts Sales & Services	P
Co-working	P
Design Services	P
Shared Workspaces & Arts Education	P
<b>Cannabis Establishment</b>	
Cannabis Cultivation	P
Cannabis Retail Sales	SP
Cannabis Research & Development	P
Cannabis Testing Laboratory	P
<b>Civic &amp; Institutional</b>	
Community Center	P
Hospital	SP
Library	P
Minor Utility Facility	SP
Museum	P
Private Non-Profit Club or Lodge	SP
Public Service	P
Religious & Educational Uses Protected by M.G.L. 40A. Sec. 3	P

P - Permitted    SP - Special Permit Required    N - Not Permitted

**Table 5.1.15 Permitted Uses (continued)**

Use Category Specific Use	HR
<b>Commercial Services</b>	
Animal Services (as noted below)	--
Commercial Kennel	SP
Pet Grooming	P
Pet Daycare & Training	SP
Veterinarian	SP
Assembly or Entertainment	SP
Banking & Financial Services (except as follows)	P
Personal Credit	SP
Broadcast and/or Recording Studio	P
Building & Home Repair Services	SP
Business Support Services	P
Caterer/Wholesale Food Production	SP
Day Care Service (as noted below)	--
Adult Day Care Center	P
Child Day Care Center	P
Educational Services	P
Maintenance & Repair of Consumer Goods	P
Personal Services (except as follows)	P
Body-Art Services	SP
Fitness Services	P
Funeral Services	SP
Health Care Services	SP
Formula Personal Services	SP
Recreation Services	SP
Vehicle Parking, Commercial (except as follows)	--
Bike Share Parking	P
Car Share Parking (3 or fewer spaces)	P
Car Share Parking (4 or more spaces)	P
Commercial Parking	P
<b>Food and Beverage Service</b>	
Bar or Tavern	P
Bakery/Café/Coffee Shop	P
Formula Food & Beverage Service	SP

P - Permitted    SP - Special Permit Required    N - Not Permitted

**Table 5.1.15 Permitted Uses (continued)**

Use Category Specific Use	HR
<b>Lodging</b>	
Bed & Breakfast	SP
Hotel or Hostel	SP
<b>Office</b>	
General Office	P
Research and Development or Laboratory	P
<b>Residential</b>	
Household Living	SP
Group Living (except as follows)	SP
Community or Group Residence	P
Dormitory or Chapter House	SP
Homeless Shelter	SP
Nursing Home/Assisted Living Facility	SP
Rooming House	SP
<b>Retail Sales</b>	
Building/Home Supplies & Equipment	SP
Consumer Goods (except as follows)	P
Alcohol Sales	SP
Firearms Sales	N
Pet Store	SP
Formula Retail	SP
Fresh Food Market or Grocery Store	P
Farm/Vendor Market	P
<b>Urban Agriculture</b>	
Farming (as noted below)	--
Commercial Farming	P
Community Farming	P
Community Gardening	P

P - Permitted    SP - Special Permit Required    N - Not Permitted

# 5. HIGH-RISE DISTRICTS

High-Rise (HR)

**Table 5.1.15 Permitted Uses (continued)**

Use Category Specific Use	HR
<b>Accessory Uses</b>	
Home Occupations (as noted below)	--
Home Office	P
Urban Agriculture (as noted below)	--
Apiculture	P
Aviculture	P
Commercial Farming	P
Residential Gardening	P

P - Permitted SP - Special Permit Required N - Not Permitted

## 16. Development Standards

- a. General
  - i. DEVELOPMENT is subject to Article 10: DEVELOPMENT STANDARDS of this Ordinance. Where the provisions of this section conflict with those of Article 10, the provisions of Article 10 apply.
- b. SIGNS
  - i. A SIGN, individual numerals or letters, or a nonelectrical nameplate identifying the property address is required for all real property as follows:
    - a). Each GROUND STORY non-residential USE must identify the STREET address either on the PRINCIPAL ENTRANCE door or above or beside the PRINCIPAL ENTRANCE of the USE.
    - b). All residential BUILDING TYPES must identify the STREET address either on the PRINCIPAL ENTRANCE door, above or beside the PRINCIPAL ENTRANCE, or on a mailbox.
  - ii. Address SIGNS must be made easily visible through the USE of colors or materials that contrast with the background material they are attached to and must be conspicuously located to provide visibility from the THOROUGHFARE that the BUILDING faces.
  - iii. Address SIGNS must be twelve (12) inches in height or less and may include the name of the occupant.

## 17. Parking & Mobility

- a. General
  - i. DEVELOPMENT is subject to the provisions of Article 11: Parking & Mobility of this Ordinance. Where the provisions of this section conflict with those of Article 11, the provisions of Article 11 apply.
  - ii. Vehicular parking must be provided as specified on Table 5.1.17, except as follows:
    - a). Non-residential USES with five thousand (5,000) square feet or less of gross LEASABLE FLOOR AREA are exempt from any minimum requirements of Table 5.1.17.
    - b). Any CHANGE IN USE within a non-residential STRUCTURE constructed before the effective date of this Ordinance, provided that the change is to a permitted USE, is exempt from any minimum requirements of Table 5.1.17.
  - iii. There are no parking requirements for ACCESSORY USES.
  - iv. MOTOR VEHICLE PARKING spaces may be shared between USES on the same LOT and buildings on the same BLOCK in accordance with §11.3 SHARED PARKING.
- b. Type
  - i. MOTOR VEHICLE PARKING may be provided as above ground STRUCTURED PARKING or underground STRUCTURED PARKING. SURFACE PARKING is prohibited.
- c. Unbundled Parking
  - i. MOTOR VEHICLE PARKING spaces must be rented or leased as an option rather than a requirement of the rental, lease, or purchase of a DWELLING UNIT, ROOMING UNIT, or non-residential floor space.
  - ii. Bicycle parking must be provided at no cost or fee to customers, visitors, employees, tenants, and residents.
- d. Driveways
  - i. New driveways require a permit from the City Engineer.
  - ii. Driveways must be compliant with all City Ordinances and constructed in accordance with all standards established by relevant City Departments.
  - iii. Driveways are not permitted in the FRONTAGE AREA between a BUILDING and the FRONT LOT LINE.
  - iv. Driveways may be no wider than twelve (12) feet in the FRONTAGE AREA OF A LOT.
  - v. Driveways may provide ACCESS in whole or in part on or across an ABUTTING LOT(s), provided that an ACCESS EASEMENT exists between all PROPERTY OWNERS.
- e. Parking Design
  - i. The design of all parking is subject to §11.1 Bicycle Parking and §11.2 MOTOR VEHICLE PARKING of this Ordinance.
- f. Parking Location

- i. Required MOTOR VEHICLE PARKING, excluding any required handicapped parking, may be provided off-SITE according to the following:
  - a). The off-SITE parking must be located within one thousand three hundred and twenty (1,320) feet of walking distance to the LOT it will serve, measured from the nearest point of the off-SITE parking along BLOCK FACES and walkways to the PRINCIPAL ENTRANCE of the USE served;
  - b). Pedestrian ACCESS to off-SITE MOTOR VEHICLE PARKING must be via a paved sidewalk or walkway.
  - c). A lease, recorded covenant, or other comparable legal instrument guaranteeing long term USE of the SITE must be provided to the review board or BUILDING OFFICIAL and executed and filed with the Registry of Deeds.
- ii. For real property located in more than one municipality, MOTOR VEHICLE PARKING need not be located within the City of Somerville.
- g. Parking Relief
  - i. Relief from the parking standards of Table 5.1.17 requires a special permit.
    - a). In its discretion to approve or deny a special permit authorizing relief from the parking standards of Table 5.1.17, the review board shall make findings considering the following in addition to the review considerations for all Special Permits specified in §15.D.1.e. Review Criteria:
      - i). The supply and demand of on-STREET parking in the neighborhood, as determined through a parking study.
      - ii). MOBILITY MANAGEMENT programs and services provided by the APPLICANT to reduce the demand for parking.

## 18. Public Realm

- a. Sidewalks
  - i. When DEVELOPMENT OCCURS on any LOT ABUTTING a sidewalk that is less than eighteen (18) feet in total width, the BUILDING must be set-back an additional distance to accommodate expansion of the ABUTTING sidewalk to a width of at least eighteen (18) feet. The minimum and maximum front SETBACKS for each BUILDING TYPE are increased accordingly.
- b. Sidewalk CURB CUTS
  - i. A CURB CUT requires a permit from the City Engineer and must be compliant with all City Ordinances.
  - ii. Unless otherwise specified, the City Engineer may not permit more than one (1) CURB CUT per FRONT LOT LINE, up to a maximum of two (2) CURB CUTS per LOT.
  - iii. CURB CUTS are prohibited along all THOROUGHFARES designated as a PEDESTRIAN STREET.

# 5. HIGH-RISE DISTRICTS

High-Rise (HR)

**Table 5.1.17 Vehicular Parking**

Use Category Specific Use	BICYCLE		MOTOR VEHICLE	
	Short-Term (min)	Long-Term (min)	Within a TRANSIT AREA <sup>1</sup> (max)	Outside of a TRANSIT AREA <sup>1</sup> (min)
<b>Arts &amp; Creative Enterprise</b>				
All Permitted Uses	1 / 10,000 sf	1 / 3,000 sf	1 / 800 sf	1 / 1,000 sf
<b>Cannabis Establishment</b>				
Cannabis Retail Sales	1 / 2,500 sf	1 / 10,000 sf	1 / 1,500 sf	1 / 750 sf
Cannabis Research & Development	1 / 20,000 sf	1 / 5,000 sf	1 / 1,000 sf	1 / 1,000 sf
Cannabis Testing Laboratory	1 / 20,000 sf	1 / 5,000 sf	1 / 1,000 sf	1 / 1,000 sf
<b>Civic &amp; Institutional</b>				
Community Center	1 / 10,000 sf	4 / 10,000 sf	1 / 1,800 sf	1 / 600 sf
Educational Facility	1.0 / classroom	4.0 / classroom	1.5 / classroom	3.0 / classroom
Hospital	10 per entrance	1 / 5,000 sf	1 / 200 sf	1 / 1,000 sf
Library	1 / 3,000 sf	1 / 5,000 sf	1 / 800 sf	1 / 500 sf
Minor Utility Facility	n/a	n/a	n/a	n/a
Museum	1 / 2,000 sf	1 / 10,000 sf	1 / 800 sf	1 / 500 sf
Private Non-Profit Club or Lodge	1 / 2,000 sf	1 / 10,000 sf	1 / 200 sf	1 / 1,000 sf
<b>Commercial Services</b>				
Animal Services (as noted below)	–	–	–	–
Commercial Kennel	1 / 2,500 sf	1 / 10,000 sf	1 / 500 sf	1 / 500 sf
Pet Grooming	1 / 2,500 sf	none	1 / 500 sf	1 / 500 sf
Pet Day Care or Training	1 / 2,500 sf	none	1 / 500 sf	1 / 500 sf
Veterinarian	1 / 2,500 sf	1 / 5,000 sf	1 / 500 sf	1 / 500 sf
Assembly or Entertainment	1 / 40 seats	1 / 10,000 sf	1 / 6 seats	1 / 6 seats
Banking & Financial Services (except as noted below)	1 / 2,000 sf	1 / 10,000 sf	1 / 450 sf	1 / 400 sf
Broadcast and/or Recording Studio	1 / 2,500 sf	1 / 10,000 sf	1 / 800 sf	1 / 600 sf
Building & Home Repair Services	1 / 2,500 sf	1 / 10,000 sf	1 / 1,000 sf	1 / 2,000 sf
Business Support Services	1 / 2,500 sf	1 / 10,000 sf	1 / 900 sf	1 / 600 sf
Caterer/Wholesale Food Production	1 / 2,500 sf	1 / 10,000 sf	1 / 800 sf	1 / 1,000 sf
Day Care Service	2	1 / 10,000 sf	1 / 900 sf	1 / 600 sf
Maintenance & Repair of Consumer Goods	1 / 2,500 sf	1 / 10,000 sf	1 / 750 sf	1 / 1,000 sf
Personal Services (except as noted below)	1 / 2,500 sf	1 / 10,000 sf	1 / 750 sf	1 / 1,000 sf
Health Care Services	1 / 2,000 sf	1 / 10,000 sf	1 / 500 sf	1 / 300 sf
Recreation Services	1 / 2,500 sf	1 / 10,000 sf	–	–

sf - Gross Leasable Square Footage

DU - Dwelling Unit RU - Rooming Unit

<sup>1</sup> See the Transit Area Map



**Table 5.1.17 Vehicular Parking (continued)**

Use Category Specific Use	BICYCLE		MOTOR VEHICLE	
	Short-Term (min)	Long-Term (min)	Within a TRANSIT AREA <sup>1</sup> (max)	Outside of a TRANSIT AREA <sup>1</sup> (min)
<b>Food and Beverage Service</b>				
All Permitted Uses	1 / 1,000 sf	1 / 5,000 sf	1 / 300 sf	1 / 500 sf
<b>Lodging</b>				
Bed & Breakfast	n/a	2.0	1 / DU + 1 / 4 guest rooms	1 / DU + 1 / 4 guest rooms
Hotel or Hostel	1 / 20 rooms	1 / 10 rooms	1 / 2 guest rooms	1 / 2 guest rooms
<b>Office</b>				
Co-Working	1 / 20,000 sf	1 / 3,000 sf	1 / 1,200 sf	1 / 800 sf
General Office	1 / 20,000 sf	1 / 3,000 sf	1 / 900 sf	1 / 650 sf
Research and Development or Laboratory	1 / 20,000 sf	1 / 5,000 sf	1 / 1,000 sf	1 / 1,000 sf
<b>Residential</b>				
Household Living	0.1 / DU	1.0 / DU	1.0 / DU	1.0 / DU
<b>Group Living (except as follows)</b>	0.05 / room	0.5 / room	–	–
Community or Group Residence	–	–	–	–
Dormitory or Chapter House	0.1 / room	0.5 / room	.05 / bed	1.0 / 4 beds
Homeless Shelter	–	–	4.0	4.0
Nursing Home/Assisted Living Facility	–	–	1 / 6 beds	1 / 6 beds
Single Room Occupancy Housing	–	–	1 / 6 beds	1 / 4 beds
<b>Retail Sales</b>				
Building/Home Supplies & Equipment	1 / 2,500 sf	1 / 10,000 sf	1 / 1,000 sf	1 / 1,000 sf
Consumer Goods (except as follows)	1 / 2,500 sf	1 / 10,000 sf	1 / 1,500 sf	1 / 750 sf
Formula Retail	1 / 2,500 sf	1 / 10,000 sf	1 / 1,500 sf	1 / 750 sf
Fresh Food Market or Grocery Store	1 / 1,000 sf	1 / 10,000 sf	1 / 500 sf	1 / 1,500 sf
Farm/Vendor Market	n/a	n/a	n/a	1 / 1,500 sf

sf - Gross Leasable Square Footage      DU - Dwelling Unit      RU - Rooming Unit

<sup>1</sup> See the Transit Area Map

## 5. HIGH-RISE DISTRICTS

High-Rise (HR)

- iv. CURB CUTS must be located to minimize conflicts with pedestrians and bicyclists and must have a clear distance from fire hydrants, STREET TREES, utility poles, and other furnishings as deemed necessary by the City Engineer.
  - a). CURB CUTS for commercial or high-volume driveways should be at least one-hundred (100) feet from an UNSIGNALIZED or SIGNALIZED intersection.
  - b). CURB CUTS for residential driveways should be at least twenty (20) feet from an UNSIGNALIZED intersection and at least forty (40) feet from a SIGNALIZED intersection.
- v. The interior width of a CURB CUT (between curb stones) may be no wider than the driveway, vehicular entrance, or loading facility it serves.
- vi. A DRIVEWAY APRON may be installed only within the furnishing zone of a sidewalk and must be constructed in accordance with all standards established by relevant City Departments.
- vii. The grade, cross slope, and clear width of the walkway of a sidewalk must be maintained between the DRIVEWAY APRON and the ABUTTING driveway. The appearance of the walkway (ie. scoring pattern or paving material) must indicate that, although a vehicle may cross, the area traversed by a vehicle remains part of the sidewalk.

**Figure 5.1.18 Sidewalk Curb Cuts**

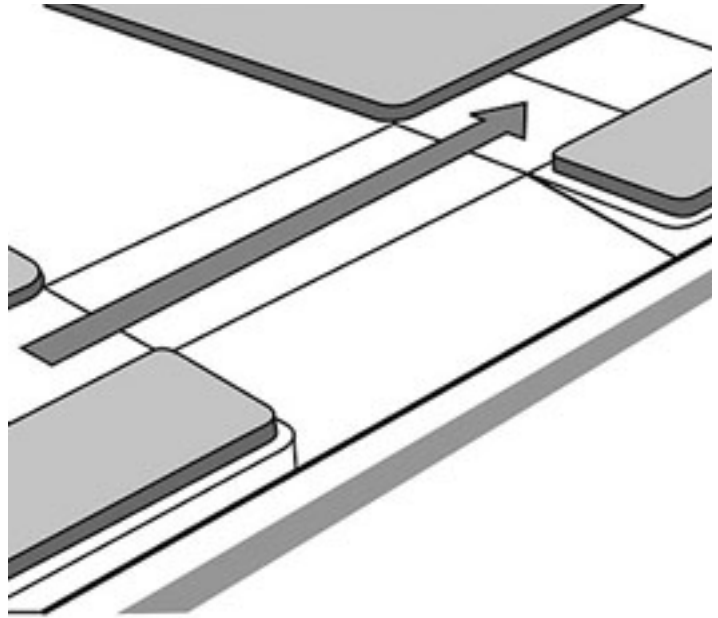

## 6 COMMERCIAL DISTRICTS

<b>6.1 FABRICATION (FAB) .....</b>	<b>267</b>	<b>6.4 COMMERCIAL BUSINESS (CB).....</b>	<b>329</b>
Description	267	Character Description	329
Intent	268	Intent	330
Purpose	268	Purpose	330
Applicability	268	Applicability	330
Development Review	268	Standards & Measurements	330
Building Types	268	Development Review	330
Building Components	273	Building Types	330
Facade Design	277	Building Components	343
Architectural Design Guidelines	277	Facade Design	347
Use Provisions	279	Architectural Design Guidelines	347
Development Standards	280	Use Provisions	348
Parking & Mobility	281	Development Standards	350
Public Realm	281	Parking & Mobility	350
		Public Realm	353
<b>6.2 COMMERCIAL CORE (CC) .....</b>	<b>285</b>		
Description	285		
Intent	286		
Purpose	286		
Applicability	286		
Development Review	286		
Building Types	286		
Building Components	299		
Facade Design	303		
Architectural Design Guidelines	303		
Use Provisions	305		
Development Standards	307		
Parking & Mobility	307		
Public Realm	310		
<b>6.3 COMMERCIAL INDUSTRY (CI) .....</b>	<b>311</b>		
Description	311		
Intent	312		
Purpose	312		
Applicability	312		
Development Review	312		
Building Types	312		
Building Components	317		
Facade Design	320		
Architectural Design Guidelines	320		
Use Provisions	321		
Development Standards	323		
Public Realm	327		



## 6.1 FABRICATION (FAB)

### 1. Description

The Fabrication district is characterized by moderate to large FLOOR PLATE buildings up to four (4) stories in height. Buildings are set close to the sidewalk to create a defined STREET wall that supports pedestrian activity and a sense of place. The district is entirely commercial with buildings typically designed or retrofitted to support multiple tenants.

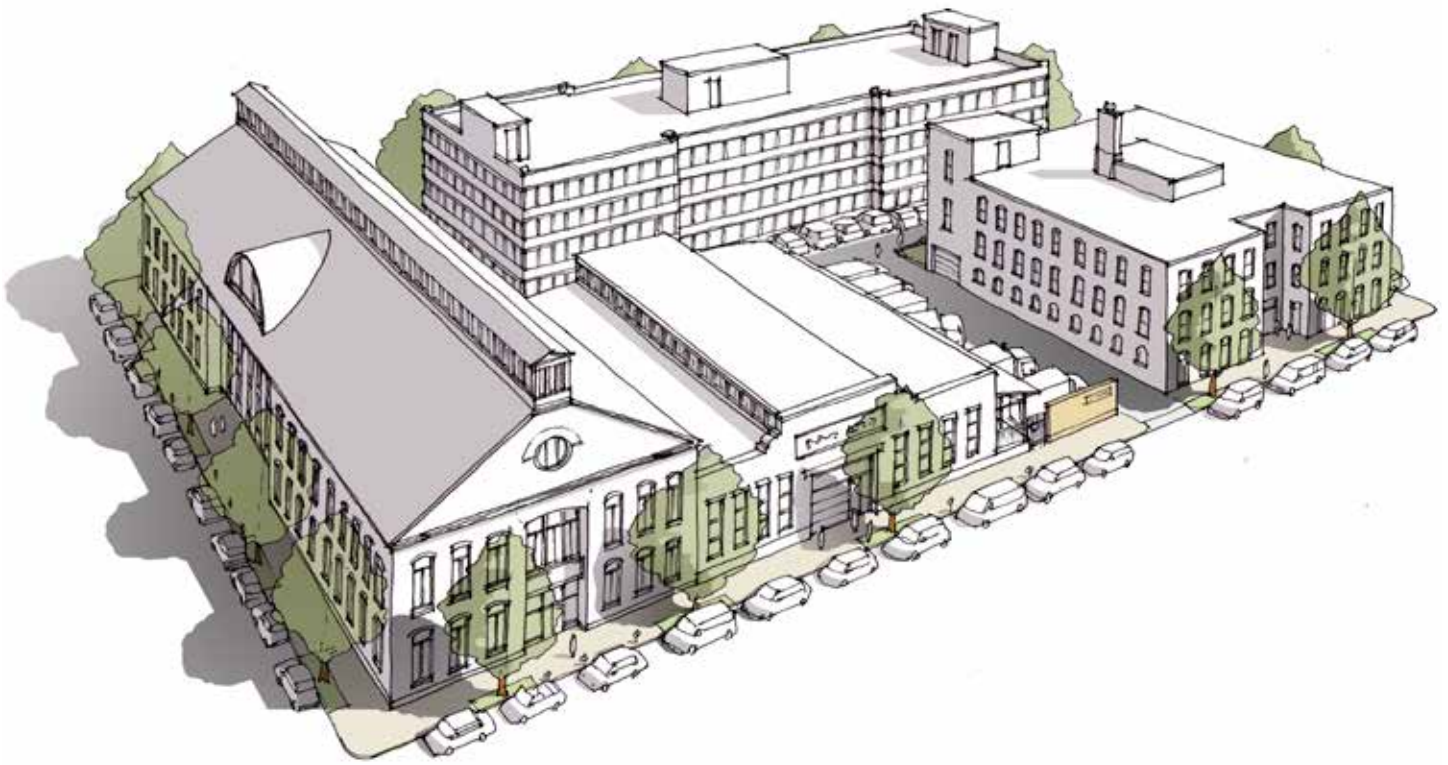

# 6.0 COMMERCIAL DISTRICTS

Fabrication (FAB)

## 2. Intent

- a. To implement the objectives of the COMPREHENSIVE PLAN of the City of Somerville related to the arts & creative economy.
- b. To protect buildings that are key assets to the creative economy of Somerville from residential conversion, preserve existing work space, and retain incubator spaces for start-up, entry-, and mid-level businesses.
- c. To create, maintain, and enhance areas appropriate for small- and moderate-scale, single- and multi-use buildings; activities common to the arts & creative economy and supporting commercial activities; and a variety of employment opportunities in the arts & creative enterprises.

## 3. Purpose

- a. To permit the DEVELOPMENT of single- and multi-use buildings that do not exceed four (4) stories in height.
- b. To provide quality commercial spaces and permit a mix of USES common to the arts & creative economy and supporting commercial activities.
- c. To prohibit residential PRINCIPAL USES.

## 4. Applicability

- a. The section is applicable to all real property within the Fabrication district as shown on maps of the Official Zoning Atlas of the City of Somerville.

## 5. Development Review

- a. DEVELOPMENT review is subject to the provisions of Article 15: Administration of this Ordinance.
- b. All DEVELOPMENT, excluding NORMAL MAINTENANCE, requires the submittal of a development review application to the BUILDING OFFICIAL and the issuance of a Certificate of Zoning Compliance prior to the issuance of a BUILDING Permit or Certificate of Occupancy.
- c. Proposed DEVELOPMENT may or may not necessitate the need for SUBDIVISION Plan Approval, Site Plan Approval, a Special Permit, or a Hardship Variance based on the nature of the proposal. In such cases, additional DEVELOPMENT review is required in accordance with Article 15: Administration.
  - i. The Planning Board is the decision making authority for all DEVELOPMENT that requires Site Plan Approval or a Special Permit.
  - ii. The Zoning Board of Appeals is the Review Board for all HARDSHIP Variances.
- d. Upon verification that no additional DEVELOPMENT review is necessary, or completion of the required DEVELOPMENT review, the BUILDING OFFICIAL shall issue a Zoning Compliance CERTIFICATE to certify compliance with the

provisions and procedures of this Ordinance.

## 6. Building Types

- a. One (1) PRINCIPAL BUILDING TYPE is permitted on each LOT.
- b. The following BUILDING TYPES are permitted by Site Plan Approval in the Fabrication district:
  - i. Fabrication BUILDING
- c. ACCESSORY STRUCTURES are regulated according to Article 10: DEVELOPMENT Standards of this Ordinance.



## 5.1.7. Fabrication Building

A moderate to large FLOOR PLATE, multi-STORY BUILDING TYPE typically designed with tall ceilings, expansive windows, wide corridors, service elevators, and loading docks. Fabrication buildings are sometimes naturally lit with a monitor, clerestory, or sawtooth roofs.

The following images are examples of the fabrication BUILDING TYPE and are intended only for illustrative purposes.



# 6.0 COMMERCIAL DISTRICTS

Fabrication (FAB)

## 7. Fabrication Building (continued)

### a. Lot Standards

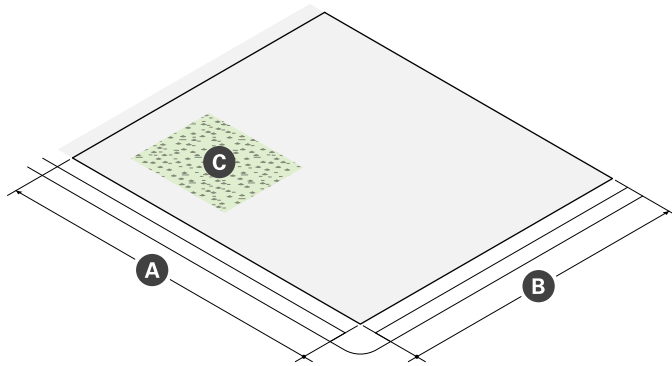

Lot Dimensions	
<b>A</b> Lot WIDTH (min)	30 ft

Lot Coverage	
Lot Coverage (max)	100%
Green Factor (min)	0.20

### b. BUILDING Placement

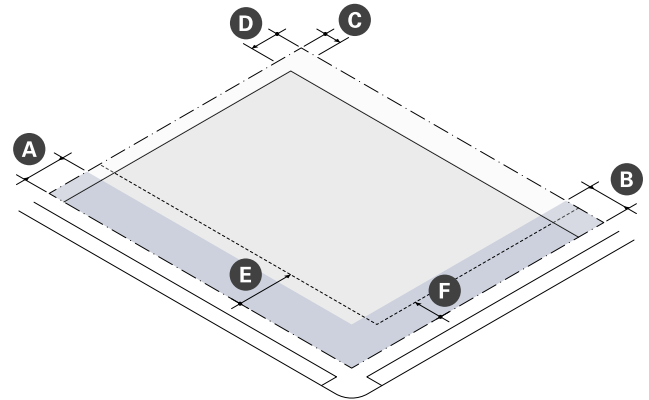

Building Setbacks		
<b>A</b> Primary Front SETBACK (min/max)	2 ft	15 ft
<b>B</b> Secondary Front SETBACK (min/max)	2 ft	15 ft
<b>C</b> Side SETBACK (min)	0 ft	
Side SETBACK ABUTTING NR or LHD (min)	10 ft	
<b>D</b> Rear SETBACK (min)	10 ft	
ALLEY	0 ft	
No ALLEY	10 ft	
No ALLEY & ABUTTING NR or LHD	15 ft	

Parking Setbacks	
<b>E</b> Primary Front SETBACK (min)	--
SURFACE PARKING	20 ft
STRUCTURED PARKING	20 ft
<b>F</b> Secondary Front SETBACK (min)	--
SURFACE PARKING	10 ft
STRUCTURED PARKING	2 ft

## 7. Fabrication Building (continued)

c. Height & Massing

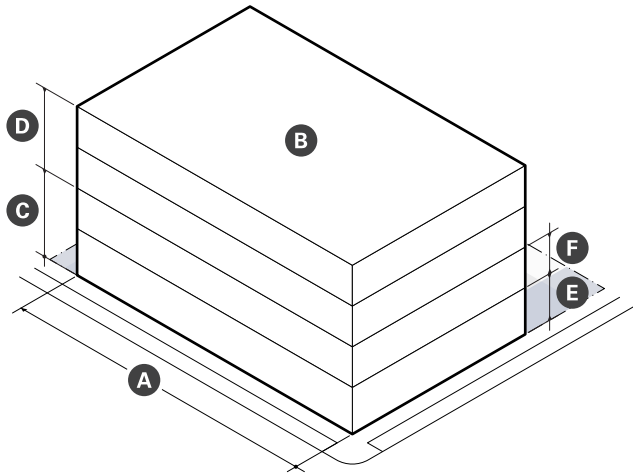

d. Uses & Features

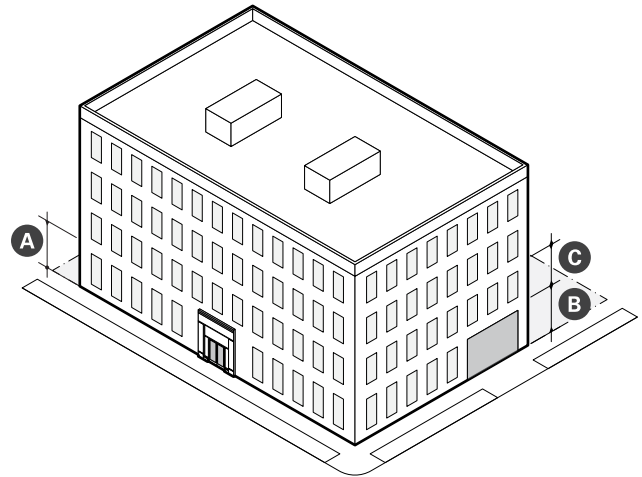

Main Mass	
<b>A</b> BUILDING WIDTH (max)	n/a
FACADE Build Out	
Primary Front (min)	65%
Secondary Front (min)	65%
<b>B</b> FLOOR PLATE (max)	30,000 sf
<b>C</b> GROUND STORY Height (min)	14 ft
<b>D</b> UPPER STORY Height (min)	10 ft
<b>E</b> Number of Stories (min/max)	2   4
<b>F</b> BUILDING Height, Feet (max)	65 ft
Roof Type	n/a

Facade Composition	
GROUND STORY FENESTRATION (min)	
<b>A</b> Primary Front	50%
<b>B</b> Secondary Front	20%
<b>C</b> UPPER STORY FENESTRATION (min/max)	20% <u>70%</u>
BLANK WALL (max)	50 ft

Use & Occupancy	
GROUND STORY Entrance Spacing (max)	n/a
Commercial Space Depth (min)	30 ft

# 6.0 COMMERCIAL DISTRICTS

Fabrication (FAB)

## 6.1.7. Fabrication Building (continued)

- e. DEVELOPMENT Benefits
  - i. DEVELOPMENT is subject to the provisions of Article 12: DEVELOPMENT Benefits of this Ordinance. Where the provisions of this section conflict with those of Article 12, the provisions of Article 12 apply.
  - ii. DEVELOPMENT of a fabrication building must provide linkage payments as specified on Table 6.1.7.

**Table 6.1.7 Linkage**

<b>Commercial GROSS FLOOR AREA</b>	<b>Affordable Housing Linkage</b>	<b>Employment Linkage</b>
<b>30,000 sf or less</b>	<b>None</b>	<b>None</b>
<b>Over 30,000 sf</b>	<b>\$10/sf</b>	<b>\$2.46/sf</b>

## 8. Building Components

- a. BUILDING COMPONENTS are ACCESSORY elements attached to the main mass of a BUILDING.
- b. Building components are permitted by Site Plan Approval as specified on Table 6.1.8.
  - i. At least one (1) storefront is required for each GROUND STORY commercial space.
- c. BUILDING COMPONENTS not identified on Table 5.1.8 are prohibited.
- d. Unless otherwise specified, BUILDING COMPONENTS may attach to other BUILDING COMPONENTS to create assemblies of components.

**Table 6.1.8 Building Components**

	General BUILDING	Commercial BUILDING	LAB BUILDING	Mid-Rise Podium Tower	Block BUILDING
Awning	P	P	P	P	P
Entry Canopy	P	P	P	P	P
Lobby Entrance	P	P	P	P	P
Storefront	P	P	P	P	P
Bay Window	P	P	P	P	P
Arcade	P	P	P	P	P

P - Permitted    SP - Special Permit Required    N - Not Permitted

# 6.0 COMMERCIAL DISTRICTS

## Fabrication (FAB)

### e. Awning

- i. An awning is a wall mounted frame covered with fabric or other material that provides shade and weather protection over a storefront or BUILDING entrance.

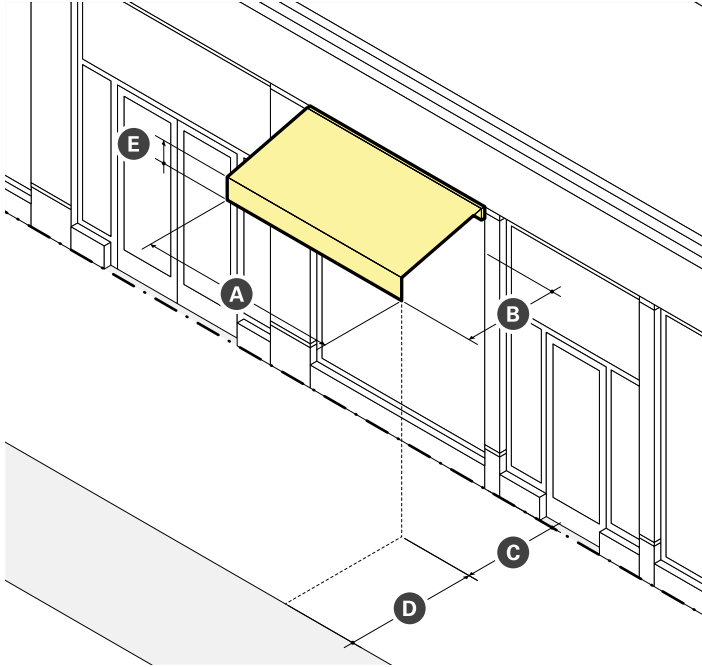

Dimensions	
<b>A</b> Width (min)	See ii Standards
<b>B</b> Projection (min)	3 ft
<b>C</b> CLEARANCE (min)	8 ft
Front SETBACK ENCROACHMENT (max)	100%
<b>D</b> SETBACK from Curb (min)	2 ft
<b>E</b> Valance Height (max)	12 in

- ii. Standards
  - a). Awnings must be securely attached to and supported by the BUILDING and must fit the windows or doors the awning is attached to.
  - b). An awning must be made of durable, weather-resistant material that is water repellent.
  - c). Internally illuminated or back-lit awnings are prohibited.
  - d). An awning that projects over the sidewalk of a public THOROUGHFARE requires compliance with all City Ordinances.

### f. Entry Canopy

- i. An entry canopy is a wall-mounted STRUCTURE that provides shade and weather protection over a storefront or BUILDING entrance.

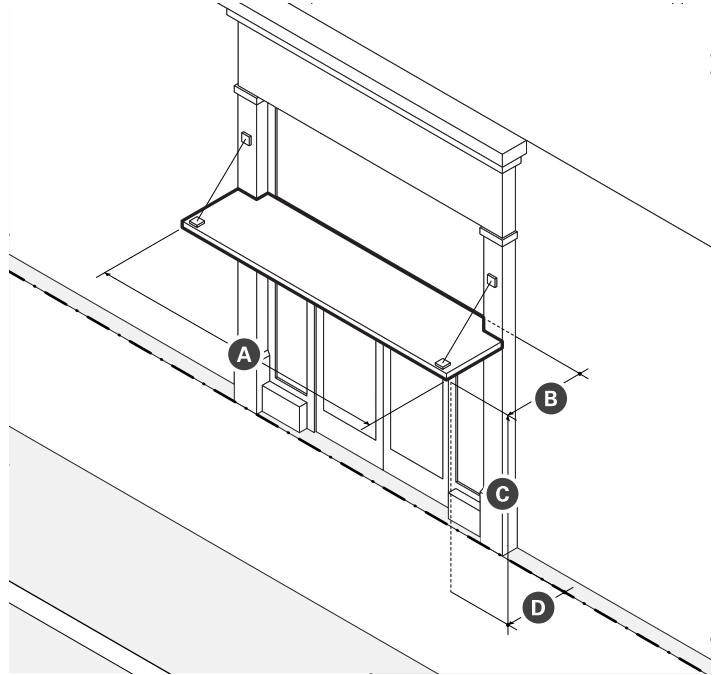

Dimensions	
<b>A</b> Width (min)	See ii Standards
<b>B</b> Projection (min)	3 ft
<b>C</b> CLEARANCE (min)	8 ft
<b>D</b> Front SETBACK ENCROACHMENT (max)	100%
SETBACK from Curb (min)	2 ft

- ii. Standards
  - a). Entry canopies must be visually supported by brackets, cables, or rods.
  - b). The width of an entry canopy must be equal to or greater than the width of the doorway surround or exterior casing it is mounted over.



## g. Lobby Entrance

- i. A lobby entrance is a non-load bearing assembly of entry doors and windows providing ACCESS and light to the lobby of a BUILDING.

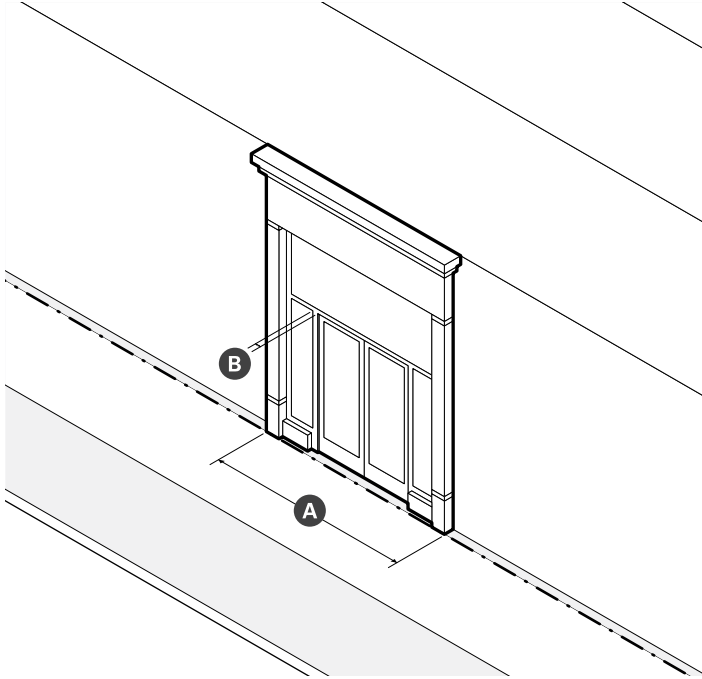

Dimensions		
<b>A</b> Width (min/max)	15 ft	30 ft
<b>B</b> Height (min)	80% of Ground Story Height	
Recessed Entrance Width (max)	15 ft	
Recessed Entrance Depth (max)	5 ft	

- ii. Standards
  - a). When a lobby entrance is set back from the FRONT LOT LINE, the FRONTAGE AREA must be paved.

## h. Storefront

- i. A storefront is a non-load bearing assembly of commercial entry doors and windows providing ACCESS and light to a commercial space and a place to display goods, services, and SIGNS.

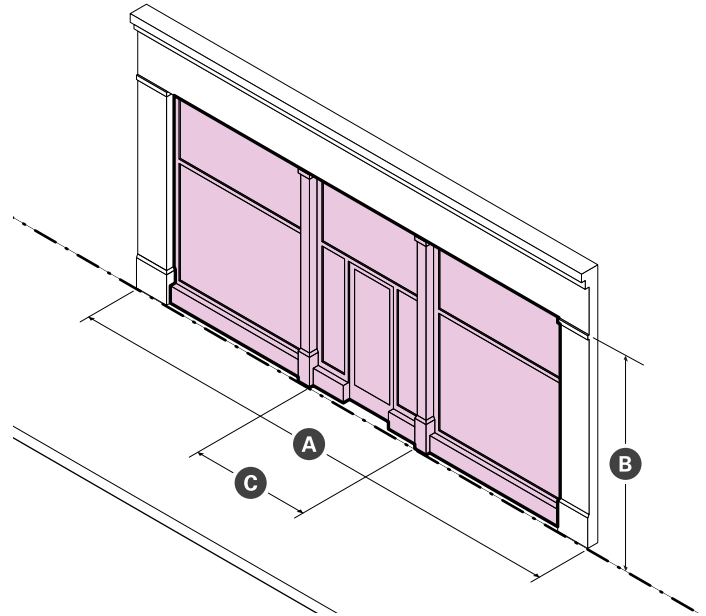

Dimensions		
<b>A</b> Width (min/max)	15 ft	30 ft
<b>B</b> Height (min)	80% of Ground Story Height	
Display Window Height (min)	8 ft	
Recessed Entrance Width (max)	15 ft	
Recessed Entrance Depth (max)	5 ft	

- ii. Standards
  - a). An unobstructed view of the interior space or a lighted and maintained merchandise display(s) must be provided for a depth of at least four (4) feet behind storefront display windows.
  - b). When storefronts are set back from the FRONT LOT LINE, the FRONTAGE AREA must be paved.
  - c). When present, awnings and canopies must be mounted between columns, PILASTERS, OR PIERS; above doorways and display windows; and below the SIGN BAND.
  - d). Exterior security grilles, gates, and roll-down security doors and windows are prohibited.

# 6.0 COMMERCIAL DISTRICTS

## Fabrication (FAB)

### i. Bay Window

- i. A bay window is an assembly of multiple windows that projects from a BUILDING to provide additional HABITABLE space, increased light, multi-directional views, and ARTICULATION to an exterior wall.

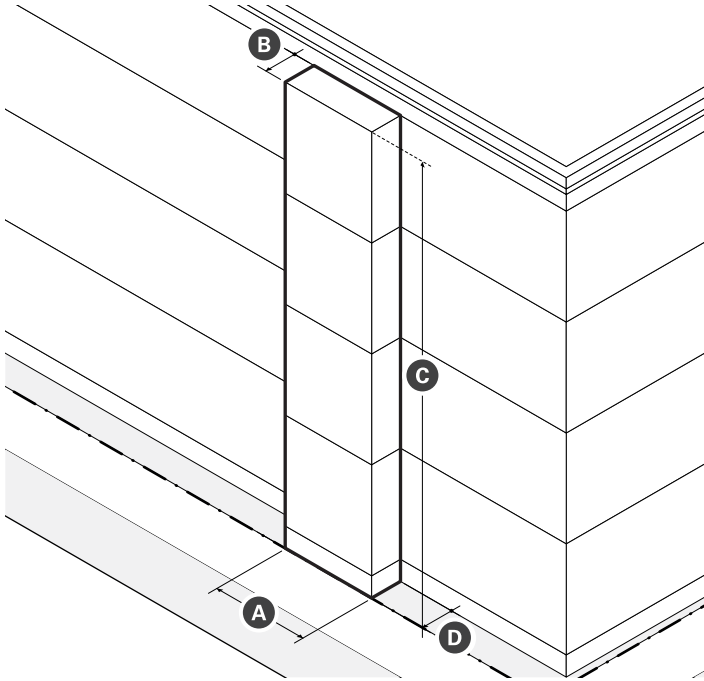

Dimensions	
<b>A</b> Width (max)	16 ft
<b>B</b> Projection (max)	3 ft
<b>C</b> Height (max)	Height of BUILDING in Stories
<b>D</b> Front SETBACK ENCROACHMENT (max)	3 ft
FENESTRATION (min)	60%

- ii. Standards
  - a). Bay windows, including box and bow windows, must include at least three (3) windows.
  - b). The cumulative width of multiple bays may equal up to fifty percent (50%) of the width of the exterior wall from which the bays project.
  - c). Bays projecting over the sidewalk of a public THOROUGHFARE must have at least two (2) stories of CLEARANCE and be compliant with all City Ordinances.

### j. Arcade

- i. An arcade is a frontage type featuring a pedestrian walkway covered by the upper floors of a BUILDING. The GROUND STORY FACADE IS SETBACK and upper floors are supported by a colonnade or supports.

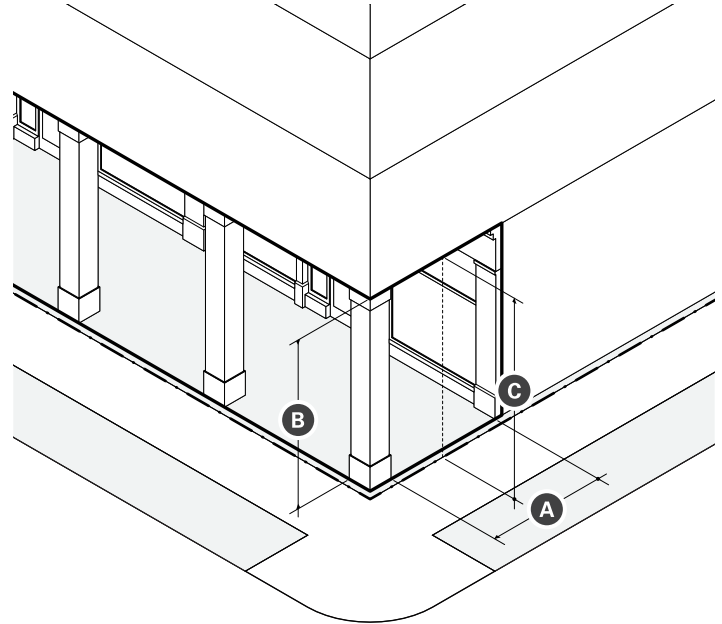

Dimensions		
<b>A</b> Depth (min/max)	10 ft	15 ft
<b>B</b> Height (max)	1 STORY	
<b>C</b> CLEARANCE (min/max)	14 ft	24 ft

- ii. Standards
  - a). Arcades must extend the entire width of a BUILDING and must have a consistent depth.
  - b). Support columns or PIERS may be spaced no farther apart than they are tall.
  - c). Arcades are considered part of the BUILDING for the purpose of measuring FACADE build out.
  - d). Arcades may be combined only with storefront and lobby entrance frontages
  - e). The finished ceiling of an arcade interior may be arched or flat, but must have a greater CLEARANCE than the openings between columns OR PIERS.

## 9. Facade Design

- a. FACADES must provide solid material framing each storefront and lobby entrance as follows:
  - i. PILASTERS or columns supporting a horizontal lintel and CORNICE;
  - ii. a spandrel positioned between PILASTERS or columns that extend from upper stories of the building to the ground; or
  - iii. flat wall above and to either side of a void or punched opening.
- b. Storefronts and lobby entrances must be set within the resulting frame provided for each by the FACADE.
- c. Materials framing each storefront or lobby entrance may be integrated into the design of the FACADE or customized for individual storefronts and lobby entrances.
- d. Mechanical louvers necessary for venting purposes are not permitted in the required frame, but may be incorporated into any storefront or lobby entrance system.

## 10. Architectural Design Guidelines

- a. FACADES should be visually divided into a series of ARCHITECTURAL BAYS that are derived, in general, from the building's structural bay spacing.
- b. PIERS, PILASTERS, or other features defining each ARCHITECTURAL BAY should either extend all the way to the ground or terminate at any horizontal ARTICULATION defining the base of the building.
- c. ARCHITECTURAL BAYS should align, in general, with

- individual or groups of storefronts and lobby entrances.
- d. PIERS, PILASTERS, or other features defining each ARCHITECTURAL BAY should always project forward and be uninterrupted by any horizontal articulation.
- e. Vents, exhausts, and other utility features on building FACADES should be architecturally integrated into the design of the building and should be located to minimize adverse effects on pedestrian comfort along sidewalks and within OPEN SPACES.
- f. Buildings at TERMINATED VISTAS should be ARTICULATED with design features that function as focal points.
- g. FENESTRATION glazing should be inset from the plane of exterior wall surfaces.
- h. RIBBON WINDOWS should be avoided.
- i. Monotonous and repetitive storefront or lobby systems, awnings, canopies, SIGN types, colors, or designs should be avoided.
- j. Storefronts and lobby entrances should include awnings or canopies to provide weather protection for pedestrians and reduce glare for storefront display areas. Awnings should be open-ended and operable.
- k. Lobby entrances for UPPER STORY USES should be optimally located, well defined, clearly visible, and separate from the entrance for other GROUND STORY USES.
- l. Lobbies should be limited in both width and total area to preserve floor space and frontage for other GROUND STORY USES. Buildings should use any combination of FACADE ARTICULATION, a double-height ceiling, a distinctive doorway, a change in wall material, a change in paving material within the FRONTAGE AREA, or some other

**Figure 5.1.13 Storefront Framing**

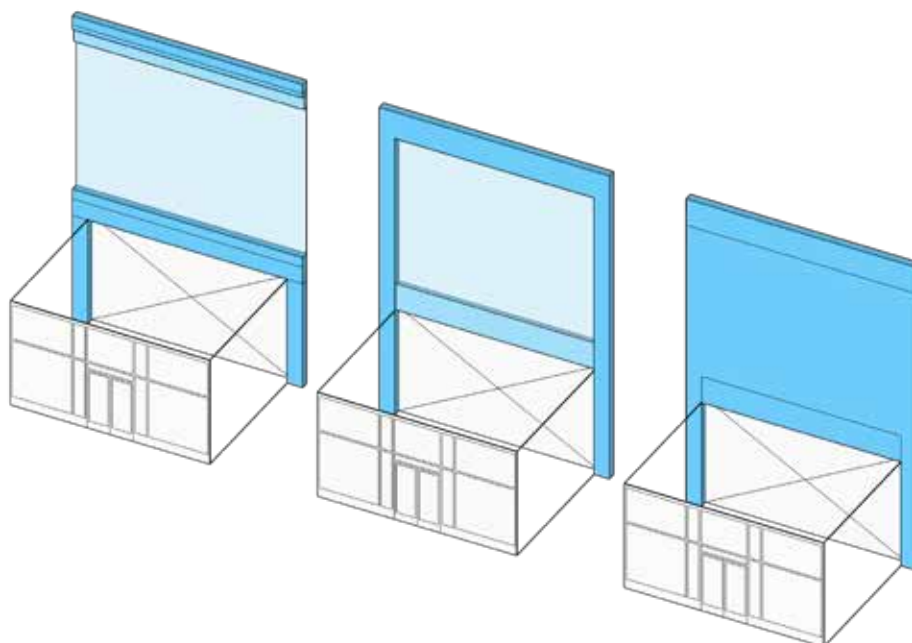

## 6.0 COMMERCIAL DISTRICTS

### Fabrication (FAB)

architectural element(s) to make lobbies visual and materially distinctive.

- m. The selection of materials, FENESTRATION, and ornamentation should result in a consistent and harmonious composition that appears as a unified whole rather than a collection of unrelated parts, no matter the style.
- n. The type and color of materials should be kept to a minimum, preferably three (3) or fewer.
- o. Two (2) or more wall materials should be combined only one above the other, except for bay windows.
- p. Wall materials appearing heavier in weight should be used below wall materials appearing lighter in weight (wood and metal above brick, and all three above stone)
- q. Horizontal or vertical board siding or shingles, regardless of material, should be avoided.
- r. Architectural details and finish materials for the base of a building should be constructed of architectural concrete or pre-cast cementitious panels, natural or cast stone, heavy gauge metal panels, glazed or unglazed architectural terracotta, or brick.
- s. Exterior Insulation and Finish Systems (EIFS) should be avoided.

## 11. Use Provisions

- a. General
  - i. The USE of real property is subject to the provisions of Article 9: USE Provisions of this Ordinance. Where the provisions of this section conflict with those of Article 9, the provisions of Article 9 apply.
  - ii. USE categories are permitted as specified on Table 6.1.11. USE categories not identified on Table 6.1.11 are prohibited.
  - iii. All USES must comply with any USE-specific standards applicable for each USE in §9.2 USE Definitions & Limitations.
  - iv. USES permitted by Special Permit require additional DEVELOPMENT review in accordance with §15.2.1 Special Permits.
- b. USE Limitations
  - i. The USE of any GROUND STORY commercial space fronting a PEDESTRIAN STREET, excluding lobbies for UPPER STORY USES, is limited to the following PRINCIPAL USE categories:
    - a). Arts & Creative Enterprise
    - b). Food & Beverage Service
    - c). Retail Sales
    - d). Civic & Institutional
- c. Required USES
  - i. A minimum of five percent (5%) of the gross leasable commercial floor space in any BUILDING must be provided as LEASABLE FLOOR AREA for USES from the Arts & Creative Enterprise USE category.

**Table 6.1.11 Permitted Uses**

Use Category Specific Use	FAB
<b>Arts &amp; Creative Enterprise</b>	
Artisinal Production	P
Arts Exhibition	P
Arts Sales & Services	P
Co-working	P
Design Services	P
Shared Workspaces & Arts Education	P
Work/Live Creative Studio	SP
<b>Cannabis Establishment</b>	
Cannabis Cultivation	P
Cannabis Product Manufacturing	P
<b>Civic &amp; Institutional</b>	
Community Center	P
Library	P
Minor Utility Facility	SP
Museum	P
Public Service	P
Religious & Educational Uses Protected by M.G.L. 40A. Sec. 3	P

P - Permitted    SP - Special Permit Required    N - Not Permitted

# 6.0 COMMERCIAL DISTRICTS

Fabrication (FAB)

**Table 6.1.11 Permitted Uses (continued)**

Use Category Specific Use	FAB
<b>Commercial Services</b>	
Broadcast and/or Recording Studio	P
Caterer/Wholesale Food Production	P
Day Care Service (as noted below)	--
Child Day Care Center	P
<b>Educational Services</b>	P
<b>Personal Services (except as follows)</b>	N
Body-Art Services	P
Fitness Services	P
Funeral Services	N
Health Care Services	N
Formula Personal Services	SP
<b>Recreation Services</b>	SP
Vehicle Parking (as noted below)	--
Bike Share Parking	P
Car Share Parking (3 or fewer spaces)	P
Car Share Parking (4 or more spaces)	P
Commercial Parking	P
<b>Industrial</b>	
Manufacturing	P
Wholesale Trade & Distribution	P
<b>Urban Agriculture</b>	
Farming (as noted below)	--
Commercial Farming	P
Community Farming	P
Community Gardening	P
<b>Accessory Uses</b>	
Urban Agriculture (as noted below)	--
Commercial Farming	P
Vehicle Parking, Accessory (except as follows)	P
Home Business Vehicle Parking	P

P - Permitted    SP - Special Permit Required    N - Not Permitted

## 12. Development Standards

- a. General
  - i. DEVELOPMENT is subject to the provisions of Article 10 SITE DEVELOPMENT of this Ordinance. Where the provisions of this section conflict with those of Article 10, the provisions of Article 10 apply.
- b. SIGNS
  - i. A SIGN, individual numerals or letters, or a nonelectrical nameplate identifying the property address is required for all real property as follows:
    - a). Each GROUND STORY non-residential USE must identify the STREET address either on the PRINCIPAL ENTRANCE door or above or beside the PRINCIPAL ENTRANCE of the USE.
    - b). All residential BUILDING TYPES must identify the STREET address either on the PRINCIPAL ENTRANCE door, above or beside the PRINCIPAL ENTRANCE, or on a mailbox.
  - ii. Address SIGNS must be made easily visible through the USE of colors or materials that contrast with the background material they are attached to and must be conspicuously located to provide visibility from the THOROUGHFARE that the BUILDING faces.
  - iii. Address SIGNS must be twelve (12) inches in height or less and may include the name of the occupant.



## 13. Parking & Mobility

- a. General
  - i. Vehicular parking must be provided as specified on Table 6.1 (d), except as follows:
    - a). Non-residential uses with five thousand (5,000) square feet or less of GROSS LEASABLE FLOOR AREA are exempt from any minimum requirements of Table 6.1.13.
    - b). Any CHANGE IN USE within a non-residential STRUCTURE constructed before the effective date of this Ordinance, provided that the change is to a permitted USE, is exempt from any minimum requirements of Table 6.1.13.
  - ii. There are no parking requirements for ACCESSORY USES.
  - iii. MOTOR VEHICLE PARKING spaces may be shared between USES on the same LOT and buildings on the same BLOCK in accordance with §11.3 SHARED PARKING.
- b. Type
  - i. MOTOR VEHICLE PARKING may be provided as above ground STRUCTURED PARKING or underground STRUCTURED PARKING. SURFACE PARKING spaces are prohibited.
- c. Driveways
  - i. New driveways require a permit from the City Engineer.
  - ii. Driveways must be compliant with all City Ordinances and constructed in accordance with all standards established by relevant City Departments.
  - iii. Driveways are not permitted in the FRONTAGE AREA between a BUILDING and the FRONT LOT LINE.
  - iv. Driveways may be no wider than twenty four (24) feet in the FRONTAGE AREA of a LOT.
  - v. Driveways may provide ACCESS in whole or in part on or across an ABUTTING LOT(s), provided that an ACCESS EASEMENT exists between all PROPERTY OWNERS.
- d. Parking Design
  - i. The design of all parking is subject to §11.1 Bicycle Parking and §11.2 MOTOR VEHICLE PARKING of this Ordinance.
- e. Parking Location
  - i. Required vehicular parking, excluding any required handicapped parking, may be provided on a contiguous LOT under the same ownership as the LOT that the parking will serve as follows:
    - a). Pedestrian ACCESS to off-SITE vehicular parking must be via a paved sidewalk or walkway.
    - b). A lease, recorded covenant, or other comparable legal instrument guaranteeing long term USE of the SITE must be provided to the review board or BUILDING OFFICIAL and executed and filed with the Registry of Deeds.
  - ii. For real property located in more than one municipality, MOTOR VEHICLE PARKING need not be located within the City of Somerville.
- f. Unbundled Parking
  - i. MOTOR VEHICLE PARKING spaces must be rented or leased as an option rather than a requirement of the rental, lease, or purchase of a DWELLING UNIT or non-residential floor space.
  - ii. Bicycle parking must be provided at no cost or fee to customers, visitors, employees, tenants, and residents.
- g. Parking Relief
  - i. Relief from the parking standards of Table 6.1.13 requires a special permit.
    - a). In addition to the review criteria for all Special Permits specified in §15.2.1.e. Review Criteria, the review board shall make findings considering the following in its discretion to approve or deny a special permit authorizing relief from the parking standards of Table 6.1.13:
      - i). The supply and demand of on-STREET parking in the neighborhood, as determined through a parking study.
      - ii). MOBILITY MANAGEMENT programs and services provided by the APPLICANT to reduce the demand for parking.
      - iii). That parking provided in excess of any maximum permitted does not result in the increase in impervious LOT AREA.

## 14. Public Realm

- a. Sidewalks
  - i. When DEVELOPMENT OCCURS on any LOT ABUTTING a sidewalk that is less than twelve (12) feet in total width, the BUILDING must be set-back an additional distance to accommodate expansion of the ABUTTING sidewalk to a width of at least twelve (12) feet. The minimum and maximum front SETBACKS for each BUILDING TYPE are increased accordingly.
- b. Sidewalk CURB CUTS
  - i. A CURB CUT requires a permit from the City Engineer and must be compliant with all City Ordinances.
  - ii. Unless otherwise specified, the City Engineer may not permit more than one (1) CURB CUT per FRONT LOT LINE of a LOT.
  - iii. CURB CUTS are prohibited along all THOROUGHFARES designated as a PEDESTRIAN STREET.
  - iv. CURB CUTS must be located to minimize conflicts with pedestrians and bicyclists and must have a clear distance from fire hydrants, STREET TREES, utility poles, and other furnishings as deemed necessary

# 6.0 COMMERCIAL DISTRICTS

Fabrication (FAB)

**Table 6.1.13 Vehicular Parking**

Use Category Specific Use	BICYCLE		MOTOR VEHICLE	
	Short-Term (min)	Long-Term (min)	Within a TRANSIT AREA <sup>1</sup> (max)	Outside of a TRANSIT AREA <sup>1</sup> (min)
<b>Arts &amp; Creative Enterprise</b>				
ALL PERMITTED USES	1 / 10,000 sf	1 / 3,000 sf	1 / 800 sf	1 / 1,000 sf
<b>Cannabis Establishment</b>				
Cannabis Product Manufacturing	1 / 10,000 sf	1 / 3,000 sf	1 / 800 sf	1 / 1,000 sf
<b>Civic &amp; Institutional</b>				
COMMUNITY CENTER	1 / 10,000 sf	4 / 10,000 sf	1 / 1,800 sf	1 / 600 sf
<b>Educational Facility</b>	1.0 / classroom	4.0 / classroom	1.5 / classroom	3.0 / classroom
LIBRARY	1 / 3,000 sf	1 / 5,000 sf	1 / 800 sf	1 / 500 sf
MINOR UTILITY FACILITY	n/a	n/a	n/a	n/a
MUSEUM	1 / 2,000 sf	1 / 10,000 sf	1 / 800 sf	1 / 500 sf
<b>Private Non-Profit Club or Lodge</b>	1 / 2,000 sf	1 / 10,000 sf	1 / 200 sf	1 / 1,000 sf
<b>Commercial Services</b>				
Broadcast and/or Recording Studio	1 / 2,500 sf	1 / 10,000 sf	1 / 800 sf	1 / 600 sf
Caterer/Wholesale Food Production	1 / 2,500 sf	1 / 10,000 sf	1 / 800 sf	1 / 1,000 sf
Day Care Service	2	1 / 10,000 sf	1 / 900 sf	1 / 600 sf
Recreation Services	1 / 2,500 sf	1 / 10,000 sf	–	–
<b>Industrial</b>				
MANUFACTURING	1 / 10,000 sf	1 / 3,000 sf	1 / 900 sf	1 / 1,200 sf
<b>Wholesale Trade &amp; Distribution</b>	1 / 40,000 sf	1 / 3,000 sf	1 / 900 sf	1 / 1,200 sf
<b>Office</b>				
GENERAL OFFICE	1 / 20,000 sf	1 / 3,000 sf	1 / 900 sf	1 / 650 sf
<b>Research and Development or Laboratory</b>	1 / 20,000 sf	1 / 5,000 sf	1 / 1,000 sf	1 / 1,000 sf

sf - Gross Leasable Square Footage

DU - DWELLING UNIT

<sup>1</sup> See the TRANSIT AREA Map

by the City Engineer.

- a). CURB CUTS for commercial or high-volume driveways should be at least one-hundred (100) feet from an UNSIGNALIZED or SIGNALIZED intersection.
- b). CURB CUTS for residential driveways should be at least twenty (20) feet from an UNSIGNALIZED intersection and at least forty (40) feet from a SIGNALIZED intersection.
- v. The interior width of a CURB CUT (between curb stones) may be no wider than the driveway, vehicular entrance, or loading facility it serves.
- vi. A DRIVEWAY APRON may be installed only within the furnishing zone of a sidewalk and must be constructed in accordance with all standards established by relevant City Departments.
- vii. The grade, cross slope, and clear width of the walkway of a sidewalk must be maintained between the DRIVEWAY APRON and the ABUTTING driveway. The appearance of the walkway (ie. scoring pattern or paving material) must indicate that, although a vehicle may cross, the area traversed by a vehicle remains part of the sidewalk.

**Figure 6.1.14 Sidewalk Curb Cuts**

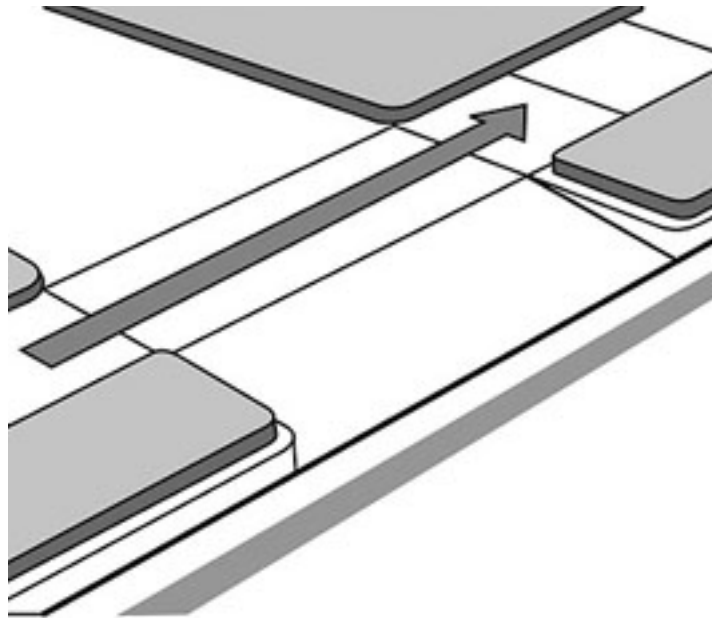

# 6.0 COMMERCIAL DISTRICTS

Fabrication (FAB)

## 6.2 COMMERCIAL CORE (CC)

### 1. Description

The Commercial Core district is characterized by medium to large FLOOR PLATE buildings at a variety of heights. Buildings are set close to the sidewalk and taller buildings have an UPPER STORY STEP-BACK to define a mid-rise STREET wall that supports pedestrian activity and a sense of place. The district is entirely commercial, with a wide diversity of USES.



# 6.0 COMMERCIAL DISTRICTS

## Commercial Core (CC)

### 2. Intent

- a. To implement the objectives of the COMPREHENSIVE PLAN of the City of Somerville for commercial DEVELOPMENT.
- b. To create, maintain, and enhance areas appropriate for moderately-scaled single- and multi-USE commercial buildings; neighborhood-, community-, and region-serving USES; and a wide variety of employment opportunities.

### 3. Purpose

- a. To permit the DEVELOPMENT of mid- and HIGH-RISE single- and multi-USE commercial buildings.
- b. To provide quality GROUND STORY commercial spaces and permit small and medium-scale, neighborhood-, community-, and region-serving commercial USES.

### 4. Applicability

- a. The section is applicable to all real property within the Commercial Core district as shown on the Official Zoning Map of the City of Somerville.
- b. The Commercial Core district is a family of sub districts where the CC zone classification is followed by a number associated with which differ only in the permitted building height on the zoning map.
- c. On the maps of the Official Zoning Atlas, the CC zone classification is followed by a number associated with the number of stories permitted for the sub-district.

### 5. Development Review

- a. DEVELOPMENT review is subject to the provisions of Article 15: Administration of this Ordinance.
- b. All DEVELOPMENT, excluding NORMAL MAINTENANCE, requires the submittal of a development review application to the BUILDING OFFICIAL and the issuance of a Certificate of Zoning Compliance prior to the issuance of a Building Permit or Certificate of Occupancy.
- c. Proposed DEVELOPMENT may or may not necessitate the need for SUBDIVISION Plan Approval, Site Plan Approval, a Special Permit, or a Hardship Variance based on the nature of the proposal. In such cases, additional DEVELOPMENT review is required in accordance with Article 15: Administration.
  - i. The Planning Board is the decision making authority for all DEVELOPMENT that requires Site Plan Approval or a Special Permit.
  - ii. The Zoning Board of Appeals is the Review Board for all HARSHIP Variances.
- d. Upon verification that no additional DEVELOPMENT review is necessary, or completion of the required DEVELOPMENT review, the BUILDING OFFICIAL shall issue a Zoning Compliance Certificate to certify compliance with the

provisions and procedures of this Ordinance.

### 6. Building Types

- a. One (1) PRINCIPAL BUILDING TYPE is permitted on each LOT.
- b. The following BUILDING TYPES are permitted by Site Plan Approval in the Commercial Core district:
  - i. Commercial Building
  - ii. Lab Building
  - iii. Commercial BLOCK Building
- c. ACCESSORY structures are regulated according to Article 10: DEVELOPMENT Standards of this Ordinance.



## 6.2.7. Commercial Building

A multi-STORY PRINCIPAL BUILDING TYPE purpose built for OCCUPATION by commercial uses on all floors. GROUND STORY commercial space is primarily occupied by commercial service, food & beverage service, or retail sales PRINCIPAL USES. Floor space on upper stories may be occupied by retail uses that do not rely on the visibility of a storefront at sidewalk level.

The following images are examples of the commercial BUILDING TYPE and are intended only for illustrative purposes.



# 6.0 COMMERCIAL DISTRICTS

Commercial Core (CC)

## 6.2.7. Commercial Building (continued)

a. Lot Standards

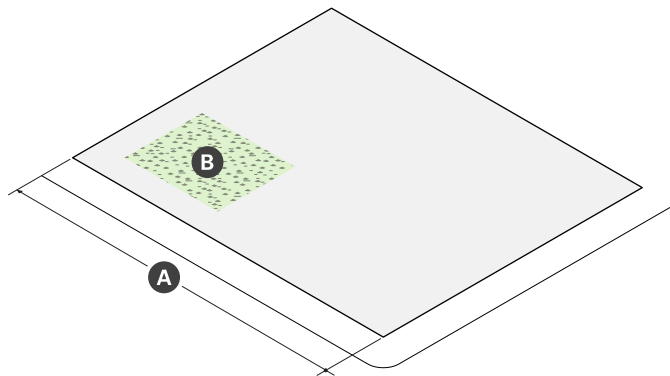

Lot Dimensions	
<b>A</b> LOT WIDTH (min)	30 ft

LOT Coverage	
LOT Coverage (max)	100%
GREEN SCORE	--
Minimum	0.20
Ideal	0.25
<b>B</b> OPEN SPACE (min)	25%

b. BUILDING Placement

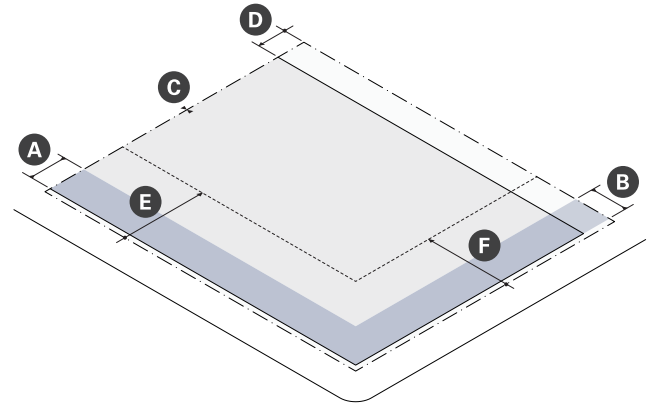

Building Setbacks		
<b>A</b> Primary Front SETBACK (min/max)	2 ft	15 ft
<b>B</b> Secondary Front SETBACK	2 ft	15 ft
<b>C</b> Side SETBACK (min)	0 ft	
Side SETBACK ABUTTING NR or LHD (min)	10 ft	
<b>D</b> Rear SETBACK (min)	--	
ALLEY	0 ft	
No ALLEY	10 ft	
No ALLEY & ABUTTING NR or LHD	15 ft	

Parking Setbacks	
<b>E</b> Primary Front SETBACK (min)	--
SURFACE PARKING	30 ft
STRUCTURED PARKING	30 ft
<b>F</b> Secondary Front SETBACK (min)	--
SURFACE PARKING	10 ft
STRUCTURED PARKING	2 ft

## 6.2.7. Commercial Building (continued)

### c. Height & Massing

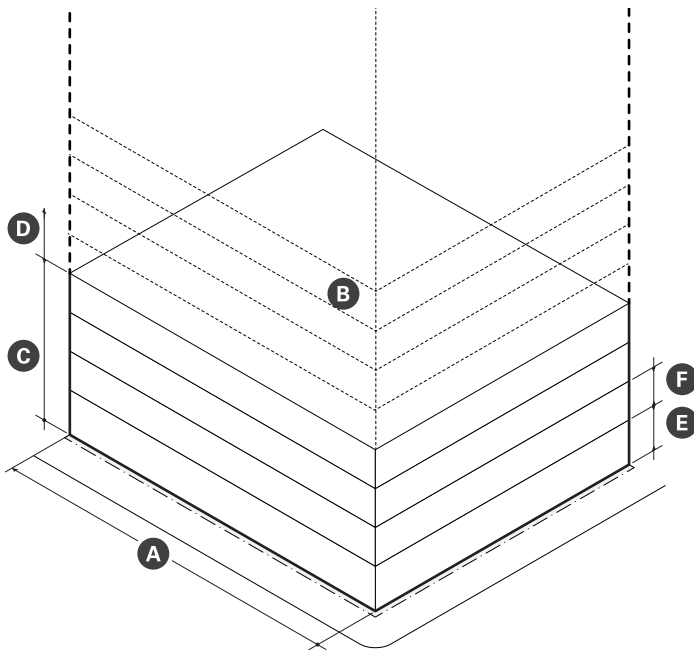

### d. Uses & Features

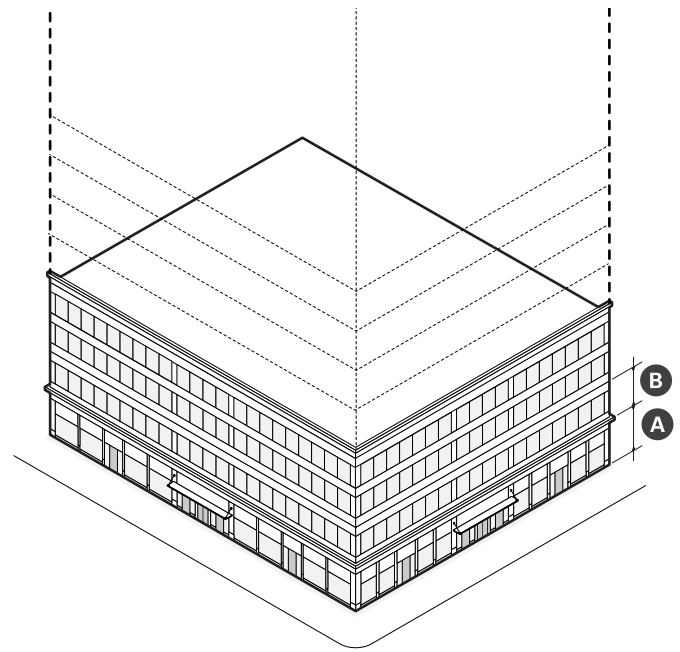

Main Mass	
<b>A</b> Width (max)	200 ft
FACADE Build Out (min)	--
Primary Frontage	80%
Secondary Frontage	65%
FLOOR PLATE (max)	30,000 sf
<b>B</b> GROUND STORY Height (min)	14 ft
<b>C</b> UPPER STORY Height (min)	10 ft
<b>D</b> BUILDING Height, Stories (min)	--
Primary Frontage	4 stories
Secondary Frontage	3 stories
<b>E</b> BUILDING Height, Stories (max)	Varies by Map Designation
<b>F</b> BUILDING Height, Feet (max)	--
3 STORY	50 ft
4 STORY	65 ft
5 STORY	75 ft
7 STORY	105 ft
10 STORY	145 ft
Roof Type	Flat

Facade Composition	
<b>A</b> GROUND STORY FENESTRATION (min)	70%
<b>B</b> UPPER STORY FENESTRATION (min/max)	20%   70%
BLANK WALL (max)	20 ft

Use & Occupancy	
Entrance Spacing (max)	30 ft
Commercial Space Depth (min)	30 ft

# 6.0 COMMERCIAL DISTRICTS

Commercial Core (CC)

## 6.2.7. Commercial Building (continued)

- e. DEVELOPMENT Benefits
  - i. DEVELOPMENT is subject to the provisions of Article 12: DEVELOPMENT Benefits of this Ordinance. Where the provisions of this section conflict with those of Article 12, the provisions of Article 12 apply.
  - ii. DEVELOPMENT of a commercial building must provide linkage payments as specified on Table 6.2.7.

**Table 6.2.7 Linkage**

<b>Commercial GROSS FLOOR AREA</b>	<b>Affordable Housing Linkage</b>	<b>Employment Linkage</b>
30,000 sf or less	None	None
Over 30,000 sf	\$10/sf	\$2.46/sf



## 6.2.8. Lab Building

A large FLOOR PLATE, multi-STORY PRINCIPAL BUILDING TYPE purpose built for occupation by laboratory and research & DEVELOPMENT PRINCIPAL USES. Floor space is typically custom designed as complex, technically sophisticated, and mechanically intensive wet or dry labs or vivariums for animal research.

The following images are examples of the lab BUILDING TYPE and are intended only for illustrative purposes.



# 6.0 COMMERCIAL DISTRICTS

Commercial Core (CC)

## 8. Lab Building (continued)

### a. LOT Standards

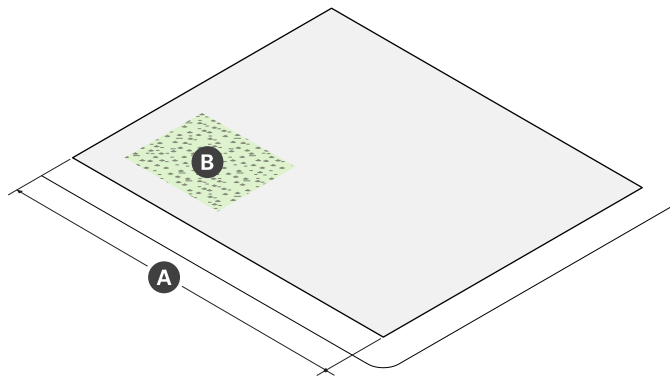

Lot Dimensions	
<b>A</b> LOT WIDTH (min)	30 ft

LOT Coverage	
LOT Coverage (max)	100%
GREEN SCORE	--
Minimum	0.20
Ideal	0.25
<b>B</b> OPEN SPACE (min)	25%

### b. BUILDING Placement

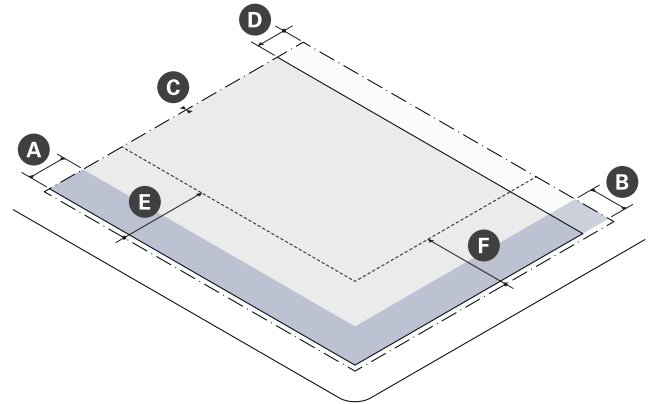

Building Setbacks		
<b>A</b> Primary Front SETBACK (min/max)	2 ft	15 ft
<b>B</b> Secondary Front SETBACK	2 ft	15 ft
<b>C</b> Side SETBACK (min)	0 ft	
Side SETBACK ABUTTING NR or LHD (min)	10 ft	
<b>D</b> Rear SETBACK (min)	--	
ALLEY	0 ft	
No ALLEY	10 ft	
No ALLEY & ABUTTING NR or LHD	15 ft	

Parking Setbacks	
<b>E</b> Primary Front SETBACK (min)	--
SURFACE PARKING	30 ft
STRUCTURED PARKING	30 ft
<b>F</b> Secondary Front SETBACK (min)	--
SURFACE PARKING	10 ft
STRUCTURED PARKING	2 ft



## 8. Lab Building (continued)

### c. Height & Massing

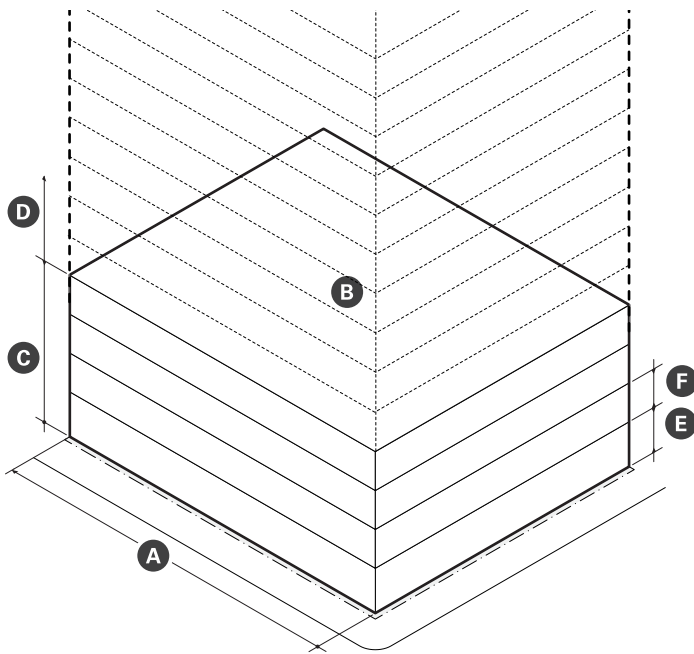

### d. Uses & Features

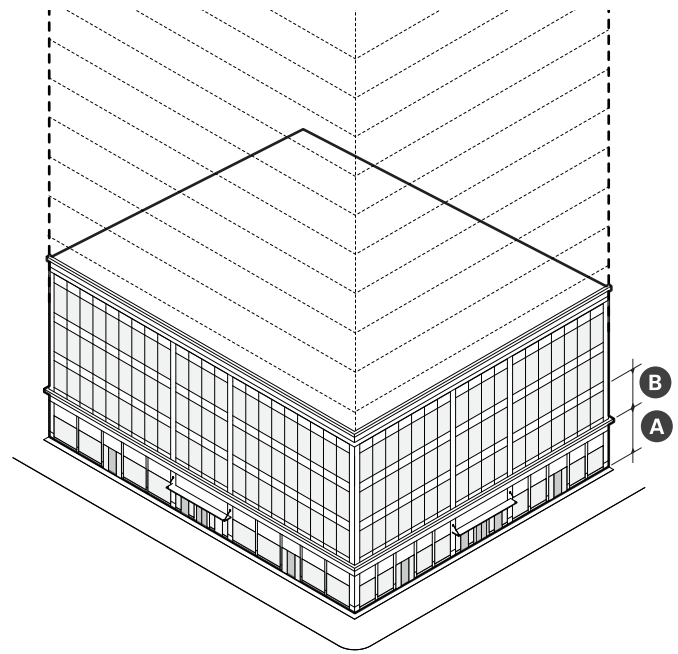

Main Mass	
<b>A</b> Width (max)	240 ft
FACADE Build Out (min)	--
Primary Frontage	80%
Secondary Frontage	65%
FLOOR PLATE	35,000 sf
<b>B</b> GROUND STORY Height (min)	14 ft
<b>C</b> UPPER STORY Height (min)	10 ft
<b>D</b> BUILDING Height, Stories (min)	--
Primary Frontage	4 stories
<b>E</b> BUILDING Height, Stories (max)	Varies by Map Designation
<b>F</b> BUILDING Height, Feet (max)	--
3 STORY	60 ft
4 STORY	75 ft
5 STORY	90 ft
7 STORY	115 ft
10 STORY	160 ft
Roof Type	Flat

Facade Composition	
<b>A</b> GROUND STORY FENESTRATION (min)	70%
<b>B</b> UPPER STORY FENESTRATION (min/max)	20%   70%
BLANK WALL (max)	20 ft

Use & Occupancy	
Entrance Spacing (max)	30 ft
Commercial Space Depth (min)	30 ft

# 6.0 COMMERCIAL DISTRICTS

Commercial Core (CC)

## 6.2.8. Lab Building (continued)

- e. DEVELOPMENT Benefits
  - i. DEVELOPMENT is subject to the provisions of Article 12: DEVELOPMENT Benefits of this Ordinance. Where the provisions of this section conflict with those of Article 12, the provisions of Article 12 apply.
  - ii. DEVELOPMENT of a general building must provide linkage payments as specified on Table 6.2.8.

**Table 6.2.8 Linkage**

<b>Commercial GROSS FLOOR AREA</b>	<b>Affordable Housing Linkage</b>	<b>Employment Linkage</b>
30,000 sf or less	None	None
Over 30,000 sf	\$10/sf	\$2.46/sf

## 6.2.9. Commercial Block Building

A very large FLOOR PLATE, multi-STORY, PRINCIPAL BUILDING TYPE composed of a three (3) to six (6) STORY PODIUM and one (1) or more UPPER STORY TOWERS with commercial uses on all stories. A BLOCK building occupies either an entire BLOCK or half of a BLOCK, on a LOT that fronts onto at least three (3) THOROUGHFARES or CIVIC SPACES. BLOCK buildings are designed to appear as an assembly of attached buildings, each with its own massing, proportions, and detailing.

The following images are examples of the BLOCK BUILDING TYPE and are intended only for illustrative purposes.



# 6.0 COMMERCIAL DISTRICTS

Commercial Core (CC)

## 11. Block Building (continued)

a. LOT Standards

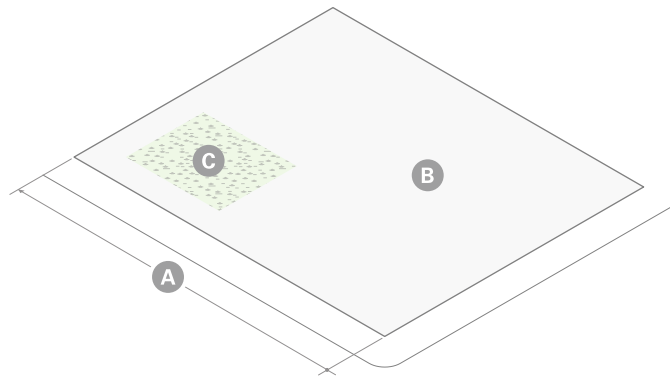

Lot Dimensions	
<b>A</b> LOT WIDTH (min)	200 ft
Depth (min)	250 ft

Lot Development	
LOT Coverage (max)	100%
GREEN SCORE	--
Minimum	0.20
Ideal	0.25
<b>B</b> OPEN SPACE (min)	25%

b. BUILDING Placement

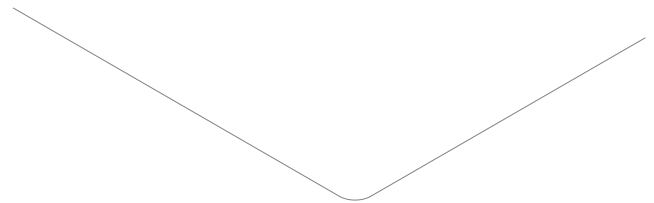

Building Setbacks		
<b>A</b> Primary Front SETBACK (min/max)	2 ft	15 ft
<b>B</b> Secondary Front SETBACK	2 ft	15 ft
<b>C</b> Side SETBACK (min)	--	
PODIUM	0 ft	
PODIUM ABUTTING NR or LHD	10 ft	
TOWER	30 ft	
TOWER ABUTTING NR or LHD	60 ft	
<b>D</b> PODIUM Rear SETBACK (min)	--	
ALLEY	0 ft	
No ALLEY	10 ft	
No ALLEY & ABUTTING NR or LHD	15 ft	
TOWER REAR SETBACK	30 ft	
ABUTTING NR or LHD	60 ft	

Parking Setbacks	
<b>E</b> Primary Front SETBACK (min)	--
SURFACE PARKING	30 ft
STRUCTURED PARKING	30 ft
<b>F</b> Secondary Front SETBACK (min)	--
SURFACE PARKING	10 ft
STRUCTURED PARKING	2 ft

## 11. Block Building (continued)

### c. Massing & Height

### d. Uses & Features

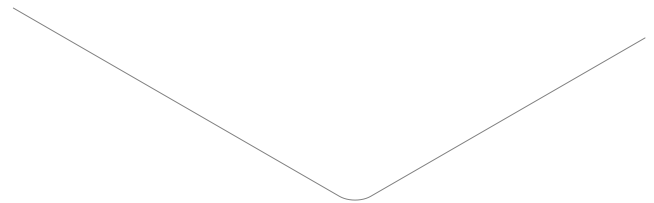
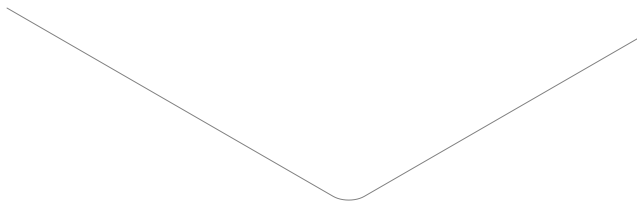

Main Mass	
<b>A</b> BUILDING WIDTH (max)	500 ft
FACADE Build Out (min)	--
Primary Front	100%
Secondary Front	100%
FLOOR PLATE (max)	--
PODIUM	n/a
TOWER(S)	30,000 sf
<b>B</b> GROUND STORY Height (min)	14 ft
<b>C</b> UPPER STORY Height (min)	10 ft
<b>D</b> Number of Stories (min)	3 stories
Number of Stories (max)	--
<b>E</b> PODIUM	6 stories
<b>F</b> TOWER(S)	10 stories
<b>G</b> Building Height (min)	10 ft
PODIUM	80 ft
TOWER	145 ft
Roof Type	Flat

Facade Composition	
<b>A</b> GROUND STORY FENESTRATION (min)	70%
<b>B</b> UPPER STORY FENESTRATION (min/max)	20%   70%
BLANK WALL (max)	20 ft

Use & Occupancy	
GROUND STORY Entrance Spacing (max)	30 ft
Commercial Space Depth (min)	30 ft



# 6.0 COMMERCIAL DISTRICTS

Commercial Core (CC)

## 6.2.9. Block Building (continued)

- e. DEVELOPMENT Benefits
  - i. DEVELOPMENT is subject to the provisions of Article 12: DEVELOPMENT Benefits of this Ordinance. Where the provisions of this section conflict with those of Article 12, the provisions of Article 12 apply.
  - ii. DEVELOPMENT of a BLOCK building must provide AFFORDABLE DWELLING UNITS as specified on Table 5.1.11 (a).
  - iii. DEVELOPMENT of a BLOCK building must provide linkage payments as specified on Table 5.1.11 (b).
- f. Building Design Standards
  - i. The FACADE of any BLOCK building greater than two hundred (200) feet in width must be designed as two (2) or more separate and distinct facades of differing architectural design so that the building appears to be multiple buildings. The facade designs must include a change in CORNICE, roof eave, or parapet design from one another.
  - ii. One (1) GROUND STORY commercial space is required per seventy (70) feet of building width, including vehicular entrances, for each BLOCK FACE.
  - iii. One (1) lobby entrance is permitted per BLOCK FACE and each TOWER must have an individual lobby entrance serving the UPPER STORY USES.
- g. DEVELOPMENT Standards
  - i. Loading facilities and services areas must be located within the building and set back from any FACADE by at least thirty (30) feet. Transformer and

**Table 6.2.9 Linkage**

Commercial GROSS FLOOR AREA	Affordable Housing Linkage	Employment Linkage
30,000 sf or less	None	None
Over 30,000 sf	\$10/sf	\$2.46/sf

- fire suppression rooms are exempt.
- h. Parking & Mobility
  - i. One (1) vehicular entrance is permitted per BLOCK FACE, but no more than two (2) vehicular entrances are permitted per BLOCK building.
- i. PUBLIC REALM
  - i. BLOCK buildings occupying an entire BLOCK must provide a covered ALLEY internal to the building.

**Figure 6.2.9 Appearance of Two Buildings**





## 10. Building Components

- a. Building components are ACCESSORY elements attached to the main mass of a building.
- b. Building components are permitted by Site Plan Approval as specified on Table 6.1.8.
  - i. At least one (1) storefront is required for each GROUND STORY commercial space.
- c. Building components not identified on Table 5.1.8 are prohibited.
- d. Unless otherwise specified, building components may attach to other building components to create assemblies of components.

**Table 6.1.8 Building Components**

	General Building	Commercial Building	Lab Building	Mid-Rise Podium Tower	Block Building
Awning	P	P	P	P	P
Entry Canopy	P	P	P	P	P
Lobby Entrance	P	P	P	P	P
Storefront	P	P	P	P	P
Bay Window	P	P	P	P	P
Arcade	P	P	P	P	P

P - Permitted    SP - Special Permit Required    N - Not Permitted

# 6.0 COMMERCIAL DISTRICTS

## Commercial Core (CC)

### e. Awning

- i. An awning is a wall mounted frame covered with fabric or other material that provides shade and weather protection over a storefront or BUILDING entrance.

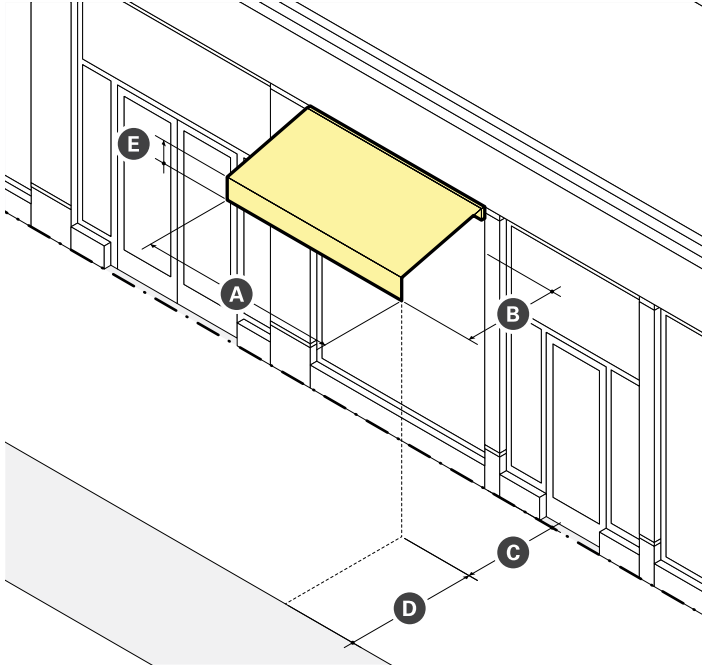

Dimensions	
<b>A</b> Width (min)	See ii Standards
<b>B</b> Projection (min)	3 ft
<b>C</b> CLEARANCE (min)	8 ft
Front SETBACK ENCROACHMENT (max)	100%
<b>D</b> SETBACK from Curb (min)	2 ft
<b>E</b> Valance Height (max)	12 in

- ii. Standards
  - a). Awnings must be securely attached to and supported by the BUILDING and must fit the windows or doors the awning is attached to.
  - b). An awning must be made of durable, weather-resistant material that is water repellent.
  - c). Internally illuminated or back-lit awnings are prohibited.
  - d). An awning that projects over the sidewalk of a public THOROUGHFARE requires compliance with all City Ordinances.

### f. Entry Canopy

- i. An entry canopy is a wall-mounted STRUCTURE that provides shade and weather protection over a storefront or BUILDING entrance.

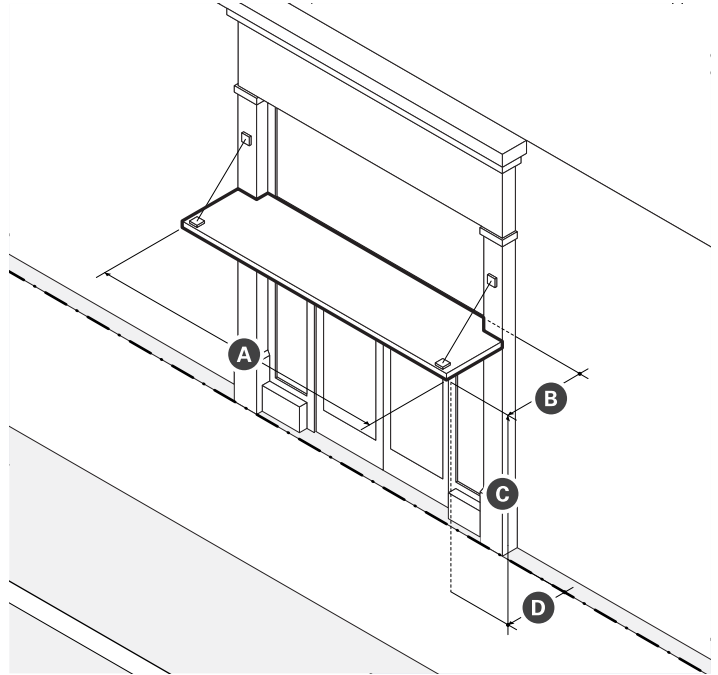

Dimensions	
<b>A</b> Width (min)	See ii Standards
<b>B</b> Projection (min)	3 ft
<b>C</b> CLEARANCE (min)	8 ft
<b>D</b> Front SETBACK ENCROACHMENT (max)	100%
SETBACK from Curb (min)	2 ft

- ii. Standards
  - a). Entry canopies must be visually supported by brackets, cables, or rods.
  - b). The width of an entry canopy must be equal to or greater than the width of the doorway surround or exterior casing it is mounted over.

## g. Lobby Entrance

- i. A lobby entrance is a non-load bearing assembly of entry doors and windows providing ACCESS and light to the lobby of a BUILDING.

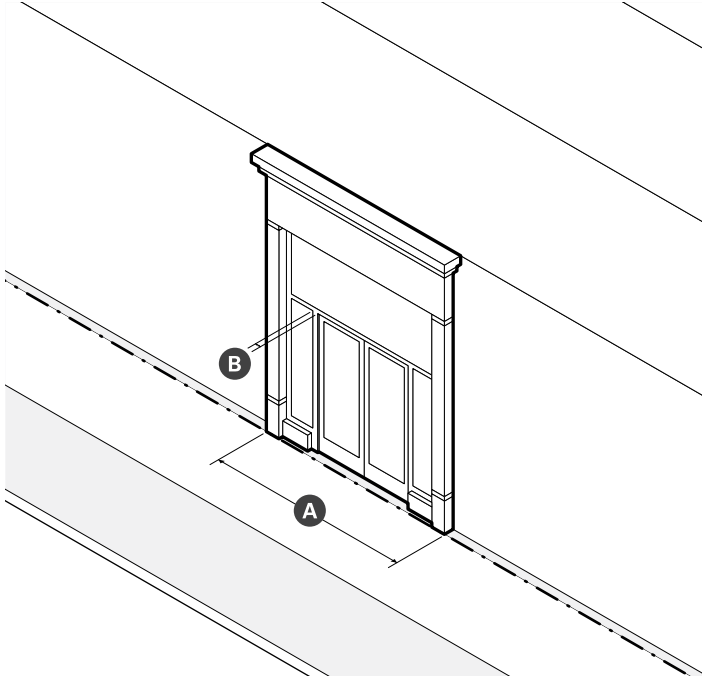

Dimensions		
<b>A</b> Width (min/max)	15 ft	30 ft
<b>B</b> Height (min)	80% of GROUND STORY Height	
Recessed Entrance Width (max)	15 ft	
Recessed Entrance Depth (max)	5 ft	

- ii. Standards
  - a). When a lobby entrance is set back from the FRONT LOT LINE, the FRONTAGE AREA must be paved.

## h. Storefront

- i. A storefront is a non-load bearing assembly of commercial entry doors and windows providing ACCESS and light to a commercial space and a place to display goods, services, and SIGNS.

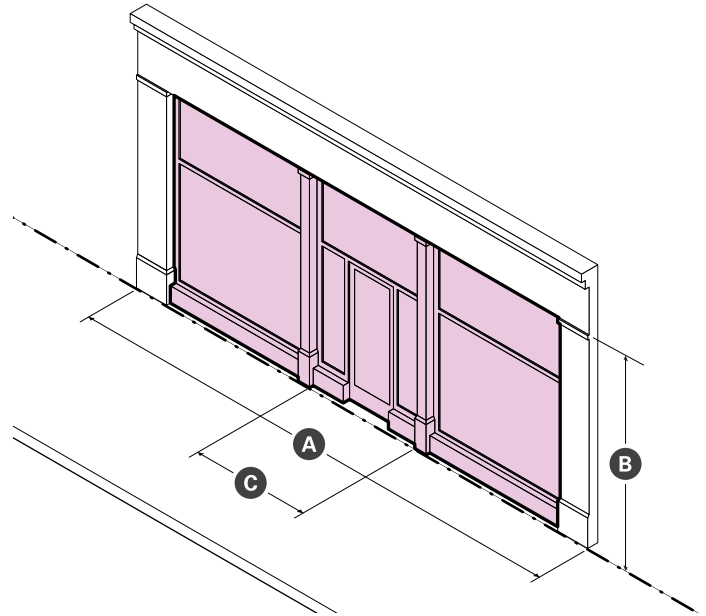

Dimensions		
<b>A</b> Width (min/max)	15 ft	30 ft
<b>B</b> Height (min)	80% of GROUND STORY Height	
Display Window Height (min)	8 ft	
Recessed Entrance Width (max)	15 ft	
Recessed Entrance Depth (max)	5 ft	

- ii. Standards
  - a). An unobstructed view of the interior space or a lighted and maintained merchandise display(s) must be provided for a depth of at least four (4) feet behind storefront display windows.
  - b). When storefronts are set back from the FRONT LOT LINE, the FRONTAGE AREA must be paved.
  - c). When present, awnings and canopies must be mounted between columns, PILASTERS, OR PIERS; above doorways and display windows; and below the SIGN BAND.
  - d). Exterior security grilles, gates, and roll-down security doors and windows are prohibited.

# 6.0 COMMERCIAL DISTRICTS

## Commercial Core (CC)

### i. Bay Window

- i. A bay window is an assembly of multiple windows that projects from a BUILDING to provide additional HABITABLE space, increased light, multi-directional views, and ARTICULATION to an exterior wall.

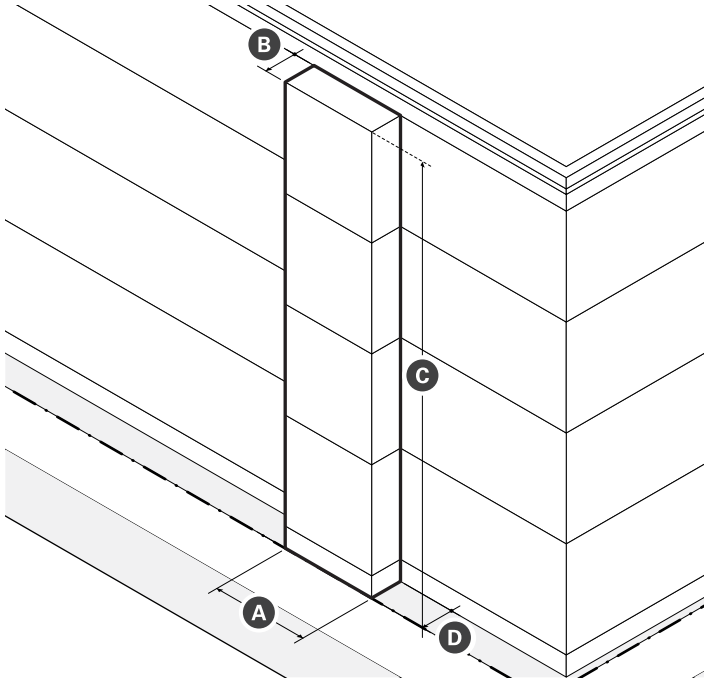

Dimensions	
<b>A</b> Width (max)	16 ft
<b>B</b> Projection (max)	3 ft
<b>C</b> Height (max)	Height of BUILDING in Stories
<b>D</b> Front SETBACK ENCROACHMENT (max)	3 ft
FENESTRATION (min)	60%

- ii. Standards
  - a). Bay windows, including box and bow windows, must include at least three (3) windows.
  - b). The cumulative width of multiple bays may equal up to fifty percent (50%) of the width of the exterior wall from which the bays project.
  - c). Bays projecting over the sidewalk of a public THOROUGHFARE must have at least two (2) stories of CLEARANCE and be compliant with all City Ordinances.

### j. Arcade

- i. An arcade is a frontage type featuring a pedestrian walkway covered by the upper floors of a BUILDING. The GROUND STORY FACADE IS SETBACK and upper floors are supported by a colonnade or supports.

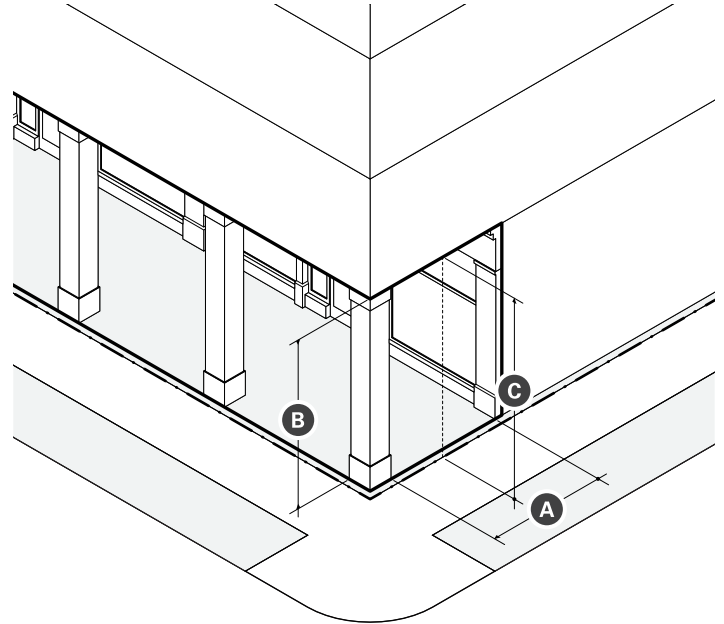

Dimensions		
<b>A</b> Depth (min/max)	10 ft	15 ft
<b>B</b> Height (max)	1 STORY	
<b>C</b> CLEARANCE (min/max)	14 ft	24 ft

- ii. Standards
  - a). Arcades must extend the entire width of a BUILDING and must have a consistent depth.
  - b). Support columns or PIERS may be spaced no farther apart than they are tall.
  - c). Arcades are considered part of the BUILDING for the purpose of measuring FACADE build out.
  - d). Arcades may be combined only with storefront and lobby entrance frontages
  - e). The finished ceiling of an arcade interior may be arched or flat, but must have a greater CLEARANCE than the openings between columns OR PIERS.

## 11. Facade Design

- a. FACADES must provide solid material framing each storefront and lobby entrance as follows:
  - i. PILASTERS or columns supporting a horizontal lintel and CORNICE;
  - ii. a spandrel positioned between PILASTERS or columns that extend from upper stories of the building to the ground; or
  - iii. flat wall above and to either side of a void or punched opening.
- b. Storefronts and lobby entrances must be set within the resulting frame provided for each by the FACADE.
- c. Materials framing each storefront or lobby entrance may be integrated into the design of the FACADE or customized for individual storefronts and lobby entrances. Mechanical louvers necessary for venting purposes are not permitted in the required frame, but may be incorporated into any storefront or lobby entrance system.
- d. FACADES must differentiate the GROUND STORY of the building from the upper stories through horizontal ARTICULATION, a change in material, or a change window size or pattern to create a distinct base to the building FACADE. The entire height of the GROUND STORY must be included in the FACADE base.
- e. The FACADE of buildings with five (5) or more stories should include, at least, the entire height of the first two (2) stories in the design of the required base. The design of the base may not shift up or down across the

width of the FACADE.

- f. For buildings with more than one FACADE, the design of the base must align horizontally at the corner.
- g. FACADES must provide surface relief from the average plane of the FACADE by at least four (4) inches, through the USE of architectural elements such as bay windows, columns, CORNER BOARDS, CORNICES, door and window surrounds, moldings, PIERS, PILASTERS, recessed storefronts or lobby entrances, seat walls, sills, wall depth, and recessed or projecting windows.

## 12. Architectural Design Guidelines

- a. FACADES
  - i. FACADES should be visually divided into a series of ARCHITECTURAL BAYS that are derived, in general, from the building's structural bay spacing.
  - ii. PIERS, PILASTERS, or other features defining each ARCHITECTURAL BAY should either extend all the way to the ground or terminate at any horizontal ARTICULATION defining the base of the building.
  - iii. ARCHITECTURAL BAYS should align, in general, with individual or groups of storefronts and lobby entrances.
  - iv. PIERS, PILASTERS, or other features defining each ARCHITECTURAL BAY should always project forward and be uninterrupted by any horizontal articulation, excluding any horizontal ARTICULATION USED to differentiate the base of the building.
  - v. The FACADE of buildings with five (5) or more stories should be visually divided into, at least, a horizontal

**Figure 5.1.13 Storefront Framing**

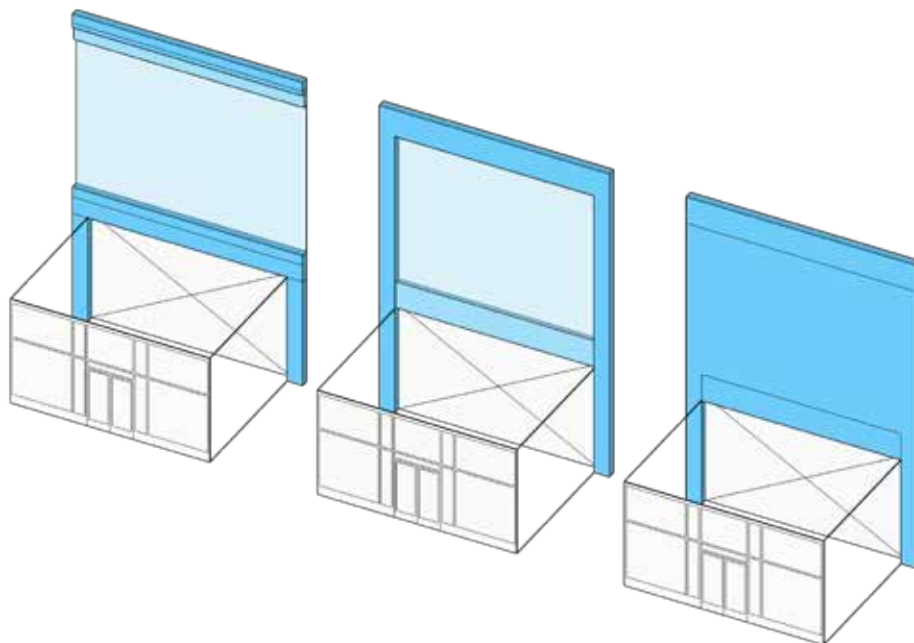

## 6.0 COMMERCIAL DISTRICTS

### Commercial Core (CC)

- tripartite division (a base, middle, and top). The horizontal divisions may not shift up or down across the width of the FACADE.
- vi. Vents, exhausts, and other utility features on building FACADES should be architecturally integrated into the design of the building and should be located to minimize adverse effects on pedestrian comfort along sidewalks and within OPEN SPACES.
  - vii. Buildings at TERMINATED VISTAS should be ARTICULATED with design features that function as focal points.
- b. FENESTRATION
- i. FENESTRATION glazing should be inset from the plane of exterior wall surfaces.
  - ii. RIBBON WINDOWS should be avoided.
- c. Storefronts & Lobby Entrances
- i. Monotonous and repetitive storefront or lobby systems, awnings, canopies, SIGN types, colors, or designs should be avoided.
  - ii. Storefronts and lobby entrances should include awnings or canopies to provide weather protection for pedestrians and reduce glare for storefront display areas. Awnings should be open-ended and operable.
  - iii. Lobby entrances for UPPER STORY USES should be optimally located, well defined, clearly visible, and separate from the entrance for other GROUND STORY USES.
  - iv. Lobbies should be limited in both width and total area to preserve floor space and frontage for other GROUND STORY USES. Buildings should USE any combination of FACADE ARTICULATION, a double-height ceiling, a distinctive doorway, a change in wall material, a change in paving material within the FRONTAGE AREA, or some other architectural element(s) to make lobbies visual and materially distinctive.
- d. Materials
- i. The selection of materials, FENESTRATION, and ornamentation should result in a consistent and harmonious composition that appears as a unified whole rather than a collection of unrelated parts, no matter the style.
  - ii. The type and color of materials should be kept to a minimum, preferably three (3) or fewer.
  - iii. Two (2) or more wall materials should be combined only one above the other, except for bay windows.
  - iv. Wall materials appearing heavier in weight should be USED below wall materials appearing lighter in weight (wood and metal above brick, and all three above stone)
  - v. Horizontal or vertical board siding or shingles, regardless of material, should be avoided.
  - vi. Architectural details and finish materials for the base of a building should be constructed of architectural concrete or pre-cast cementitious panels, natural or cast stone, heavy gauge metal panels, glazed or unglazed architectural terracotta, or brick.
  - vii. Exterior Insulation and Finish Systems (EIFS) should be avoided.



### 13. Use Provisions

- a. General
  - i. The USE of real property is subject to the provisions of Article 9: Use Provisions of this Ordinance. Where the provisions of this section conflict with those of Article 9, the provisions of Article 9 apply.
  - ii. USE categories are permitted according to Table 6.2.13.
  - iii. All USES must comply with any USE-specific standards applicable for each USE in §9.2 USE Definitions & Limitations.
  - iv. USES permitted by Special Permit require additional DEVELOPMENT review in accordance with §15.2.1 Special Permits.
  - v. USE categories not identified on Table 6.2.13 are prohibited.
- b. USE Limitations
  - i. The USE of any GROUND STORY commercial space fronting a PEDESTRIAN STREET, excluding lobbies for UPPER STORY USES, is limited to the following PRINCIPAL USE categories:
    - a). Arts & Creative Enterprise
    - b). Food & Beverage Service
    - c). Retail Sales
    - d). Civic & Institutional
- c. Required USES
  - i. A minimum of five percent (5%) of the GROSS FLOOR AREA of any Commercial BUILDING or Lab BUILDING must be provided as LEASABLE FLOOR AREA for USES from the Arts & Creative Enterprise USE category.

**Table 6.2.13 Permitted Uses**

Use Category Specific Use	CC
<b>Arts &amp; Creative Enterprise</b>	
Artisinal Production	P
Arts Exhibition	P
Arts Sales & Services	P
Co-Working	P
Design Services	P
Shared Workspaces & Arts Education	P
<b>Cannabis Establishment</b>	
Cannabis Cultivation	P
Cannabis Retail Sales	SP
Cannabis Research & Development	P
Cannabis Testing Laboratory	P
<b>Civic &amp; Institutional</b>	
Community Center	P
Hospital	SP
Library	P
Minor Utility Facility	SP
Museum	P
Private Non-Profit Club or Lodge	SP
Public Service	P
Religious & Educational Uses Protected by M.G.L. 40A. Sec. 3	P

P - Permitted    SP - Special Permit Required    N - Not Permitted

# 6.0 COMMERCIAL DISTRICTS

Commercial Core (CC)

**Table 6.2.13 Permitted Uses (continued)**

Use Category Specific Use	CC
<b>Commercial Services</b>	
Animal Services (as noted below)	--
Commercial Kennel	SP
Pet Grooming	P
Pet Daycare & Training	SP
Veterinarian	SP
Assembly or Entertainment	SP
Banking & Financial Services (except as follows)	P
Personal Credit	SP
Broadcast and/or Recording Studio	P
Building & Home Repair Services	SP
Business Support Services	P
Caterer/Wholesale Food Production	SP
Day Care Service (as noted below)	--
Adult Day Care Center	P
Child Day Care Center	P
Educational Services	P
Maintenance & Repair of Consumer Goods	P
Personal Services (except as noted below)	P
Body-Art Services	SP
Funeral Services	SP
Fitness Services	P
Health Care Services	SP
Formula Personal Services	SP
Recreation Services	SP
Vehicle Parking (as noted below)	P
Bike Share Parking	P
Car Share Parking (3 or fewer spaces)	P
Car Share Parking (4 or more spaces)	P
Commercial Parking	P
<b>Food and Beverage Service</b>	
Bar/Restaurant/Tavern	P

P - Permitted SP - Special Permit Required N - Not Permitted

**Table 6.2.13 Permitted Uses (continued)**

Use Category Specific Use	CC
Bakery/Café/Coffee Shop	P
Formula Food & Beverage Service	SP
<b>Lodging</b>	
Bed & Breakfast	SP
Hotel or Hostel	SP
<b>Office</b>	
General Office	P
Research and Development or Laboratory	P
<b>Retail Sales</b>	
Building/Home Supplies & Equipment	SP
Consumer Goods (except as follows)	P
Alcohol Sales	SP
Firearms Sales	N
Pet Store	SP
Formula Retail	SP
Fresh Food Market or Grocery Store	P
Farm/Vendor Market	P
<b>Urban Agriculture</b>	
Farming (as noted below)	--
Commercial Farming	P
Community Farming	P
Community Gardening	P
<b>Accessory Uses</b>	
Urban Agriculture (as noted below)	--
Commercial Farming	P

P - Permitted SP - Special Permit Required N - Not Permitted

## 14. Development Standards

- a. General
  - i. DEVELOPMENT is subject to the provisions of Article 10 SITE DEVELOPMENT of this Ordinance. Where the provisions of this section conflict with those of Article 10, the provisions of Article 10 apply.
- b. SIGNS
  - i. A SIGN, individual numerals or letters, or a nonelectrical nameplate identifying the property address is required for all real property as follows:
    - a). Each GROUND STORY non-residential USE must identify the STREET address either on the PRINCIPAL ENTRANCE door or above or beside the PRINCIPAL ENTRANCE of the USE.
    - b). All residential BUILDING TYPES must identify the STREET address either on the PRINCIPAL ENTRANCE door, above or beside the PRINCIPAL ENTRANCE, or on a mailbox.
  - ii. Address SIGNS must be made easily visible through the USE of colors or materials that contrast with the background material they are attached to and must be conspicuously located to provide visibility from the THOROUGHFARE that the BUILDING faces.
  - iii. Address SIGNS must be twelve (12) inches in height or less and may include the name of the occupant.

## 15. Parking & Mobility

- a. General
  - i. DEVELOPMENT is subject to the provisions of Article 11: Parking & Mobility of this Ordinance. Where the provisions of this section conflict with those of Article 11, the provisions of Article 11 apply.
  - ii. Vehicular parking must be provided as specified on Table 6.2.15, except as follows:
    - a). Non-residential USES with five thousand (5,000) square feet or less of GROSS LEASABLE FLOOR AREA are exempt from any minimum requirements of Table 6.2.15.
    - b). Any CHANGE IN USE within a non-residential STRUCTURE constructed before the effective date of this Ordinance, provided that the change is to a permitted USE, is exempt from any minimum requirements of Table 6.2.15.
  - iii. There are no parking requirements for ACCESSORY USES.
  - iv. MOTOR VEHICLE PARKING spaces may be shared between USES on the same LOT and buildings on the same BLOCK in accordance with §11.3 SHARED PARKING.
- b. Type
  - i. MOTOR VEHICLE PARKING may be provided as above ground STRUCTURED PARKING or underground

- STRUCTURED PARKING. SURFACE PARKING is prohibited.
- c. Driveways
  - i. New driveways require a permit from the City Engineer.
  - ii. Driveways must be compliant with all City Ordinances and constructed in accordance with all standards established by relevant City Departments.
  - iii. Driveways are not permitted in the FRONTAGE AREA between a BUILDING and the FRONT LOT LINE.
  - iv. Driveways may be no wider than twenty four (24) feet in the FRONTAGE AREA of a LOT.
  - v. Driveways may provide ACCESS in whole or in part on or across an ABUTTING LOT(s), provided that an ACCESS EASEMENT exists between all PROPERTY OWNERS.
- d. Parking Design
  - i. The design of all parking is subject to §11.1 Bicycle Parking and §11.2 MOTOR VEHICLE PARKING of this Ordinance.
- e. Parking Location
  - i. Required vehicular parking, excluding any required handicapped parking, may be provided on a contiguous LOT under the same ownership as the LOT that the parking will serve as follows:
    - a). Pedestrian ACCESS to off-SITE vehicular parking must be via a paved sidewalk or walkway.
    - b). A lease, recorded covenant, or other comparable legal instrument guaranteeing long term USE of the SITE must be provided to the review board or BUILDING OFFICIAL and executed and filed with the Registry of Deeds.
  - ii. For real property located in more than one municipality, MOTOR VEHICLE PARKING need not be located within the City of Somerville.
- f. Unbundled Parking
  - i. MOTOR VEHICLE PARKING spaces must be rented or leased as an option rather than a requirement of the rental, lease, or purchase of a DWELLING UNIT or non-residential floor space.
  - ii. Bicycle parking must be provided at no cost or fee to customers, visitors, employees, tenants, and residents.
- g. Parking Relief
  - i. Relief from the parking standards of Table 6.2.15 requires a Special Permit.
    - a). In addition to the review criteria for all Special Permits specified in §15.2.1.e. Review Criteria, the review board shall make findings considering the following in its discretion to approve or deny a special permit authorizing relief from the parking standards of Table 4.4 (d):
      - i). The supply and demand of on-STREET parking in the neighborhood, as

# 6.0 COMMERCIAL DISTRICTS

Commercial Core (CC)

**Table 6.2.15 Vehicular Parking**

Use Category Specific Use	BICYCLE		MOTOR VEHICLE	
	Short-Term (min)	Long-Term (min)	Within a TRANSIT AREA <sup>1</sup> (max)	Outside of a TRANSIT AREA <sup>1</sup> (min)
<b>Arts &amp; Creative Enterprise</b>				
All Permitted Uses	1 / 10,000 sf	1 / 3,000 sf	1 / 800 sf	1 / 1,000 sf
<b>Cannabis Establishment</b>				
Cannabis Retail Sales	1 / 2,500 sf	1 / 10,000 sf	1 / 1,500 sf	1 / 750 sf
Cannabis Research & Development	1 / 20,000 sf	1 / 5,000 sf	1 / 1,000 sf	1 / 1,000 sf
Cannabis Testing Laboratory	1 / 20,000 sf	1 / 5,000 sf	1 / 1,000 sf	1 / 1,000 sf
<b>Civic &amp; Institutional</b>				
Community Center	1 / 10,000 sf	4 / 10,000 sf	1 / 1,800 sf	1 / 600 sf
Educational Facility	1.0 / classroom	4.0 / classroom	1.5 / classroom	3.0 / classroom
Hospital	10 per entrance	1 / 5,000 sf	1 / 200 sf	1 / 1,000 sf
Library	1 / 3,000 sf	1 / 5,000 sf	1 / 800 sf	1 / 500 sf
Minor Utility Facility	n/a	n/a	n/a	n/a
Museum	1 / 2,000 sf	1 / 10,000 sf	1 / 800 sf	1 / 500 sf
Private Non-Profit Club or Lodge	1 / 2,000 sf	1 / 10,000 sf	1 / 200 sf	1 / 1,000 sf
<b>Commercial Services</b>				
Animal Services (as noted below)	–	–	–	–
Commercial Kennel	1 / 2,500 sf	1 / 10,000 sf	1 / 500 sf	1 / 500 sf
Pet Grooming	1 / 2,500 sf	none	1 / 500 sf	1 / 500 sf
Pet Day Care or Training	1 / 2,500 sf	none	1 / 500 sf	1 / 500 sf
Veterinarian	1 / 2,500 sf	1 / 5,000 sf	1 / 500 sf	1 / 500 sf
Assembly or Entertainment	1 / 40 seats	1 / 10,000 sf	1 / 6 seats	1 / 6 seats
Banking & Financial Services (except as noted below)	1 / 2,000 sf	1 / 10,000 sf	1 / 450 sf	1 / 400 sf
Broadcast and/or Recording Studio	1 / 2,500 sf	1 / 10,000 sf	1 / 800 sf	1 / 600 sf
Building & Home Repair Services	1 / 2,500 sf	1 / 10,000 sf	1 / 1,000 sf	1 / 2,000 sf
Business Support Services	1 / 2,500 sf	1 / 10,000 sf	1 / 900 sf	1 / 600 sf
Caterer/Wholesale Food Production	1 / 2,500 sf	1 / 10,000 sf	1 / 800 sf	1 / 1,000 sf
Day Care Service	2	1 / 10,000 sf	1 / 900 sf	1 / 600 sf
Maintenance & Repair of Consumer Goods	1 / 2,500 sf	1 / 10,000 sf	1 / 750 sf	1 / 1,000 sf
Personal Services (except as noted below)	1 / 2,500 sf	1 / 10,000 sf	1 / 750 sf	1 / 1,000 sf
Health Care Services	1 / 2,000 sf	1 / 10,000 sf	1 / 500 sf	1 / 300 sf
Recreation Services	1 / 2,500 sf	1 / 10,000 sf	–	–

sf - Gross Leasable Square Footage

DU - Dwelling Unit RU - Rooming Unit

<sup>1</sup> See the Transit Area Map

**Table 6.2.15 Vehicular Parking (continued)**

Use Category Specific Use	BICYCLE		MOTOR VEHICLE	
	Short-Term (min)	Long-Term (min)	Within a TRANSIT AREA <sup>1</sup> (max)	Outside of a TRANSIT AREA <sup>1</sup> (min)
<b>Food and Beverage Service</b>				
All Permitted Uses	1 / 1,000 sf	1 / 5,000 sf	1 / 300 sf	1 / 500 sf
<b>Lodging</b>				
Bed & Breakfast	1 / 20 rooms	1 / 10 rooms	1 / DU + 1 / 4 guest rooms	1 / DU + 1 / 4 guest rooms
Hotel or Hostel	1 / 20 rooms	1 / 10 rooms	1 / 2 guest rooms	1 / 2 guest rooms
Short Term Rental	1 / 20 rooms	1 / 10 rooms	n/a	n/a
<b>Office</b>				
Co-Working	1 / 20,000 sf	1 / 3,000 sf	1 / 1,200 sf	1 / 800 sf
General Office	1 / 20,000 sf	1 / 3,000 sf	1 / 900 sf	1 / 650 sf
Research and Development or Laboratory	1 / 20,000 sf	1 / 5,000 sf	1 / 1,000 sf	1 / 1,000 sf
<b>Retail Sales</b>				
Building/Home Supplies & Equipment	1 / 2,500 sf	1 / 10,000 sf	1 / 1,000 sf	1 / 1,000 sf
Consumer Goods (except as follows)	1 / 2,500 sf	1 / 10,000 sf	1 / 1,500 sf	1 / 750 sf
Formula Retail	1 / 2,500 sf	1 / 10,000 sf	1 / 1,500 sf	1 / 750 sf
Fresh Food Market or Grocery Store	1 / 1,000 sf	1 / 10,000 sf	1 / 500 sf	1 / 1,500 sf
Farm/Vendor Market	n/a	n/a	n/a	1 / 1,500 sf

sf - Gross Leasable Square Footage      DU - Dwelling Unit      RU - Rooming Unit

<sup>1</sup> See the Transit Area Map

## 6.0 COMMERCIAL DISTRICTS

### Commercial Core (CC)

- determined through a parking study.
- ii). MOBILITY MANAGEMENT programs and services provided by the APPLICANT to reduce the demand for parking.
- iii). That parking provided in excess of any maximum permitted does not result in the increase in impervious LOT AREA.

#### 16. Public Realm

##### a. Sidewalks

- i. When DEVELOPMENT OCCURS on any LOT ABUTTING a sidewalk that is less than twelve (12) feet in total width, the BUILDING must be set-back an additional distance to accommodate expansion of the ABUTTING sidewalk to a width of at least twelve (12) feet. The minimum and maximum front SETBACKS for each BUILDING TYPE are increased accordingly.

##### b. Sidewalk CURB CUTS

- i. A CURB CUT requires a permit from the City Engineer and must be compliant with all City Ordinances.
- ii. Unless otherwise specified, the City Engineer may not permit more than one (1) CURB CUT per FRONT LOT LINE, up to a maximum of two (2) CURB CUTS per LOT.
- iii. CURB CUTS are prohibited along all THOROUGHFARES designated as a PEDESTRIAN STREET.
- iv. CURB CUTS must be located to minimize conflicts with pedestrians and bicyclists and must have a clear distance from fire hydrants, STREET TREES, utility poles, and other furnishings as deemed necessary by the City Engineer.
  - a). CURB CUTS for commercial or high-volume driveways should be at least one-hundred (100) feet from an UNSIGNALIZED or SIGNALIZED intersection.
  - b). CURB CUTS for residential driveways should be at least twenty (20) feet from an UNSIGNALIZED intersection and at least forty (40) feet from a SIGNALIZED intersection.
  - c). Multiple CURB CUTS serving the same LOT or BUILDING must be at least one hundred and fifty

**Figure 6.2.16 Sidewalk Curb Cuts**

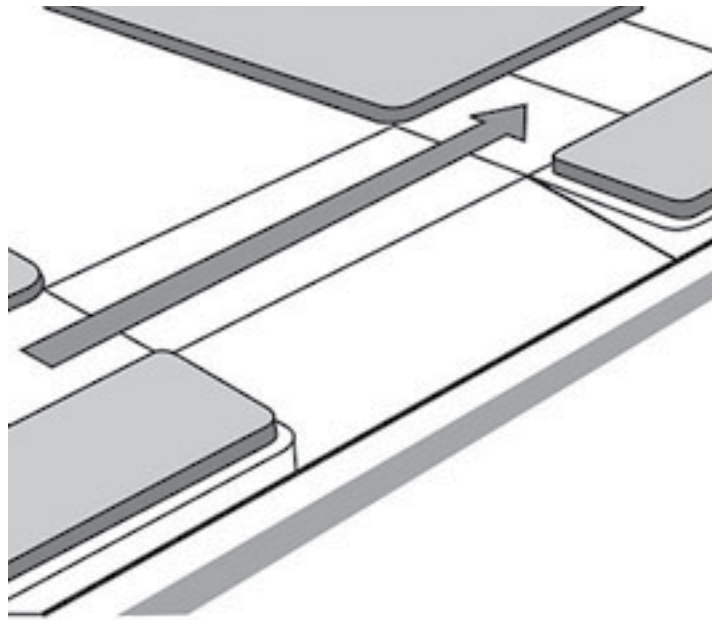

- (150) feet apart from one another.
- v. The interior width of a CURB CUT (between curb stones) may be no wider than the driveway, vehicular entrance, or loading facility it serves.
- vi. A DRIVEWAY APRON may be installed only within the furnishing zone of a sidewalk and must be constructed in accordance with all standards established by relevant City Departments.
- vii. The grade, cross slope, and clear width of the walkway of a sidewalk must be maintained between the DRIVEWAY APRON and the ABUTTING driveway. The appearance of the walkway (ie. scoring pattern or paving material) must indicate that, although a vehicle may cross, the area traversed by a vehicle remains part of the sidewalk.



## 6.3 COMMERCIAL INDUSTRY (CI)

### 1. Description

The Commercial Industry district is characterized by large FLOOR PLATE buildings up to four (4) stories in height. Buildings are typically SETBACK by parking and include warehouse and factory styles along with multi STORY offices.

The district is entirely commercial, with uses that are typically auto-oriented, commercial service, industrial, or office in nature.

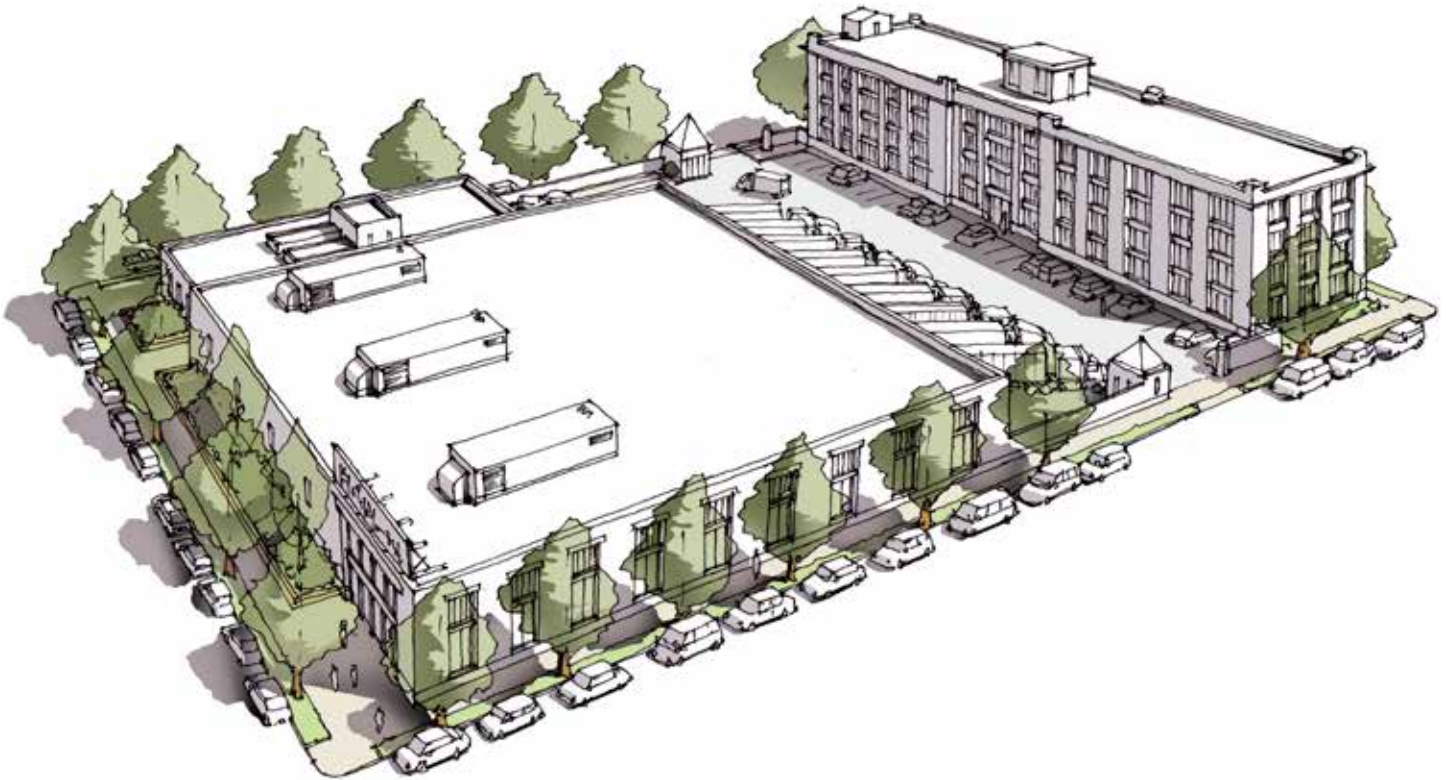

# 6.0 COMMERCIAL DISTRICTS

## Commercial Industry (CI)

### 2. Intent

- a. To maintain industrial and commercial activities that provide employment opportunities and business-to-business commerce.
- b. To maintain already existing areas appropriate for moderate- and large-scale, low-rise and mid-rise buildings and community- and region-serving commercial uses that do not readily assimilate into other zoning districts.

### 3. Purpose

- a. To permit the DEVELOPMENT of moderate-scale low- and mid-rise buildings.
- b. To provide quality commercial spaces and permit light & moderate industrial and large commercial uses.

### 4. Applicability

- a. The section is applicable to all real property within the Commercial Industry district as shown on the Official Zoning Map of the City of Somerville.

### 5. Development Review

- a. DEVELOPMENT review is subject to the provisions of Article 15: Administration of this Ordinance.
- b. All DEVELOPMENT, excluding NORMAL MAINTENANCE, requires the submittal of a development review application to the BUILDING OFFICIAL and the issuance of a Certificate of Zoning Compliance prior to the issuance of a Building Permit or Certificate of Occupancy.
- c. Proposed DEVELOPMENT may or may not necessitate the need for SUBDIVISION Plan Approval, Site Plan Approval, a Special Permit, or a Hardship Variance based on the nature of the proposal. In such cases, additional DEVELOPMENT review is required in accordance with Article 15: Administration.
  - i. The Zoning Board of Appeals is the decision making authority for all DEVELOPMENT in the Commercial Business district.
- d. Upon verification that no additional DEVELOPMENT review is necessary, or completion of the required DEVELOPMENT review, the BUILDING OFFICIAL shall issue a Zoning Compliance Certificate to certify compliance with the

provisions and procedures of this Ordinance.

### 6. Building Types

- a. One (1) PRINCIPAL BUILDING TYPE is permitted on each LOT.
- b. The following BUILDING TYPES are permitted by Site Plan Approval in the Commercial Core district:
  - i. Commercial Building
- c. ACCESSORY structures are regulated according to Article 10: DEVELOPMENT Standards of this Ordinance.

## 6.3.7. Commercial Building

A single to multi-STORY BUILDING TYPE purpose built for OCCUPATION by commercial USES on all floors.

The following images are examples of the commercial BUILDING TYPE and are intended only for illustrative purposes.



# 6.0 COMMERCIAL DISTRICTS

Commercial Industry (CI)

## 6.3.7. Commercial Building (continued)

a. Lot Standards

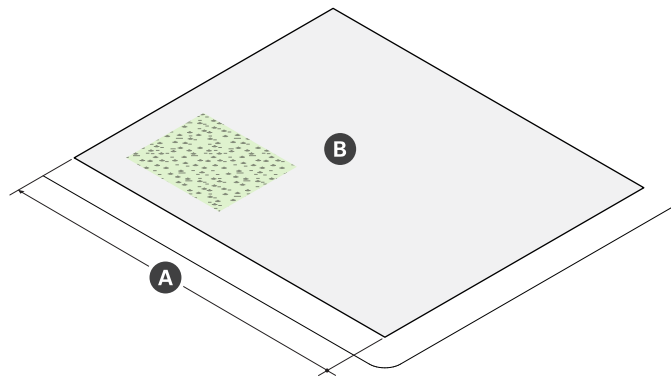

Lot Dimensions	
<b>A</b> Lot Width (min)	30 ft

Lot Coverage	
Lot Coverage (max)	100%
Green Factor (min)	0.20

b. BUILDING Placement

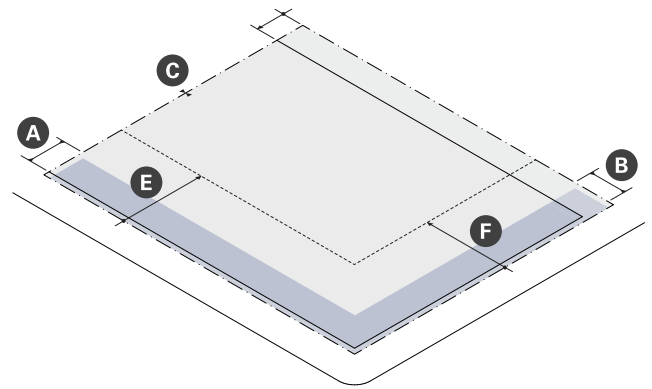

Building Setbacks		
<b>A</b> Primary Front SETBACK (min)		0 ft
<b>B</b> Secondary Front SETBACK (min)		0 ft
<b>C</b> Side SETBACK (min)		0 ft
	Side SETBACK ABUTTING NR or LHD (min)	10 ft
<b>D</b> Rear SETBACK (min)		10 ft
	Rear SETBACK ABUTTING NR (min)	15 ft

Parking Setbacks		
<b>E</b> Primary Front SETBACK (min)		10 ft
<b>F</b> Secondary Front SETBACK (min)		--
	SURFACE PARKING	10 ft
	STRUCTURED PARKING	10 ft

## 6.3.7. Commercial Building (continued)

### c. Height & Massing

### d. Uses & Features

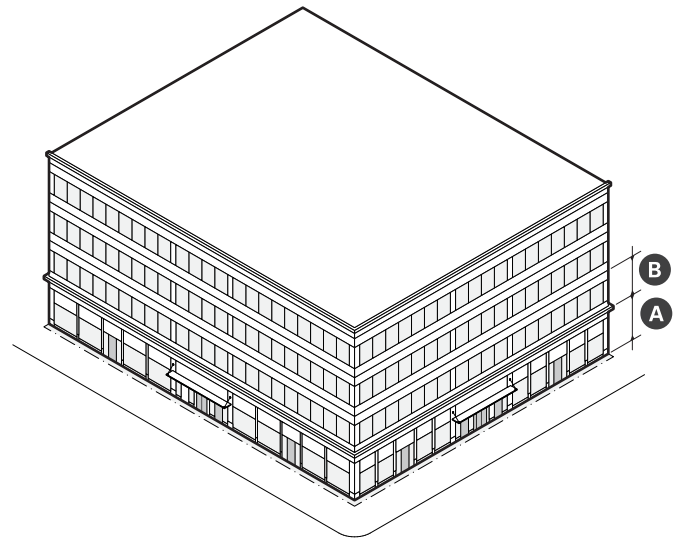
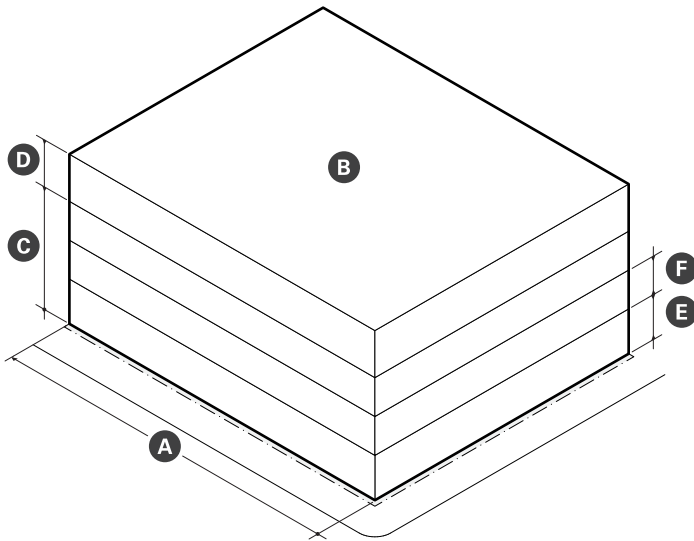

Main Mass	
<b>A</b> Width (max)	300 ft
FACADE Build Out (min)	--
Primary Frontage	80%
Secondary Frontage	65%
<b>B</b> FLOOR PLATE	50,000 sf
<b>C</b> GROUND STORY Height (min)	14 ft
<b>D</b> UPPER STORY Height (min)	10 ft
<b>E</b> Number of Stories (max)	4 stories
<b>F</b> BUILDING Height, Feet (max)	65 feet
Roof Type	Flat

Facade Composition	
<b>A</b> GROUND STORY FENESTRATION (min)	20%
<b>B</b> UPPER STORY FENESTRATION (min)	20%
BLANK WALL (max)	50 ft

# 6.0 COMMERCIAL DISTRICTS

Commercial Industry (CI)

## 6.3.7. Commercial Building (continued)

- e. DEVELOPMENT Benefits
  - i. DEVELOPMENT is subject to the provisions of Article 12: DEVELOPMENT Benefits of this Ordinance. Where the provisions of this section conflict with those of Article 12, the provisions of Article 12 apply.
  - ii. DEVELOPMENT of a general building must provide linkage payments as specified on Table 6.3.7.

**Table 6.3.7 Linkage**

<b>Commercial GROSS FLOOR AREA</b>	<b>Affordable Housing Linkage</b>	<b>Employment Linkage</b>
30,000 sf or less	None	None
Over 30,000 sf	\$10/sf	\$2.46/sf



## 8. Building Components

- a. BUILDING COMPONENTS are ACCESSORY elements attached to the main mass of a PRINCIPAL BUILDING.
- b. Building components are permitted by Site Plan Approval as specified on Table 6.1.8.
  - i. At least one (1) storefront is required for each GROUND STORY commercial space.
- c. BUILDING COMPONENTS not identified on Table 5.1.8 are prohibited.
- d. Unless otherwise specified, BUILDING COMPONENTS may attach to other BUILDING COMPONENTS to create assemblies of components.

**Table 6.1.8 Building Components**

	General Building	Commercial Building	Lab Building	Mid-Rise Podium Tower	Block Building
Awning	P	P	P	P	P
Entry Canopy	P	P	P	P	P
Lobby Entrance	P	P	P	P	P
Storefront	P	P	P	P	P

P - Permitted    SP - Special Permit Required    N - Not Permitted

# 6.0 COMMERCIAL DISTRICTS

Commercial Industry (CI)

## e. Awning

- i. A wall mounted, pitched covering extending from a BUILDING to provide shade and weather protection for pedestrians.

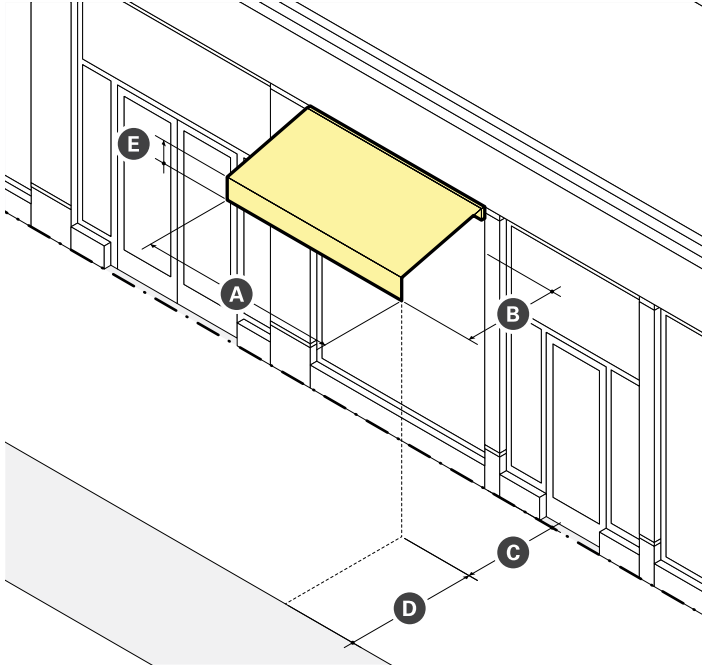

Dimensions	
<b>A</b> Width (min)	See §X
<b>B</b> Projection (min)	3 ft
<b>C</b> CLEARANCE (min)	8 ft clear
<b>D</b> SETBACK from Curb (min)	1.5 ft
<b>E</b> Valance Height (max)	12 in

- ii. Standards
  - a). Awnings must be securely attached to and supported by the BUILDING and must fit the windows or doors the awning is attached to.
  - b). An awning must be made of durable, weather-resistant material that is water repellent.
  - c). Internally illuminated or back-lit awnings are prohibited.
  - d). An awning that projects over the sidewalk of a public THOROUGHFARE requires compliance with all City Ordinances.

## f. Entry Canopy

- i. An entry canopy is a wall-mounted STRUCTURE that provides shade and weather protection over the entrance of a BUILDING.

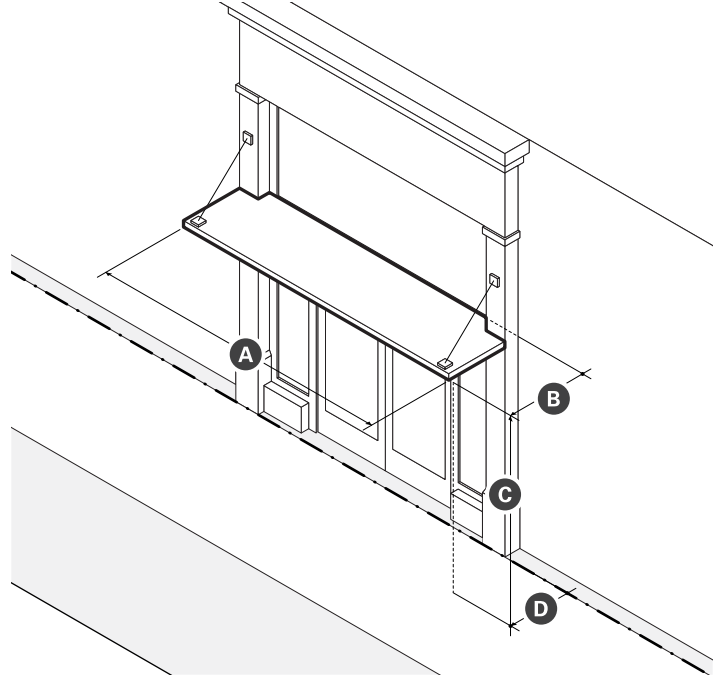

Dimensions	
<b>A</b> Width (min)	See §X
<b>B</b> Depth (max)	3 ft
<b>C</b> CLEARANCE (min)	8 ft clear
<b>D</b> Permitted SETBACK ENCROACHMENT (max)	100%

- ii. Standards
  - a). Entry canopies must be visually supported by brackets, cables, or rods.
  - b). The width of an entry canopy must be equal to or greater than the width of the doorway surround or exterior casing it is mounted over.

## g. Lobby Entrance

- i. A lobby entrance is a non-load bearing assembly of entry doors and windows providing ACCESS and light to the lobby of a BUILDING.

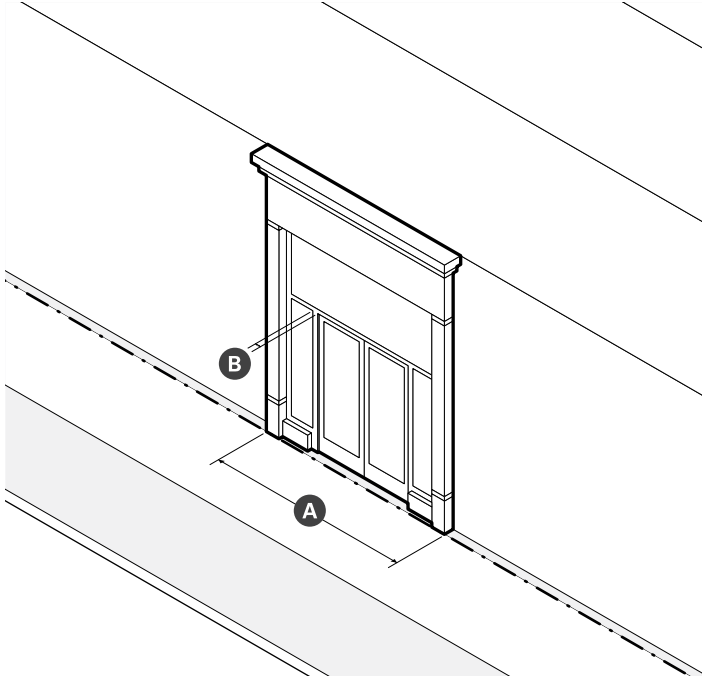

Dimensions		
<b>A</b> Width (min/max)	15 ft	30 ft
Recessed Entrance Width (max)	15 ft	
Recessed Entrance Depth (max)	5 ft	

- ii. Standards
  - a). When a lobby entrance is set back from the FRONT LOT LINE, the FRONTAGE AREA must be paved.

## h. Storefront

- i. A storefront is a non-load bearing assembly of commercial entry doors and windows providing ACCESS and light to a commercial space and a place to display goods, services, and SIGNS.

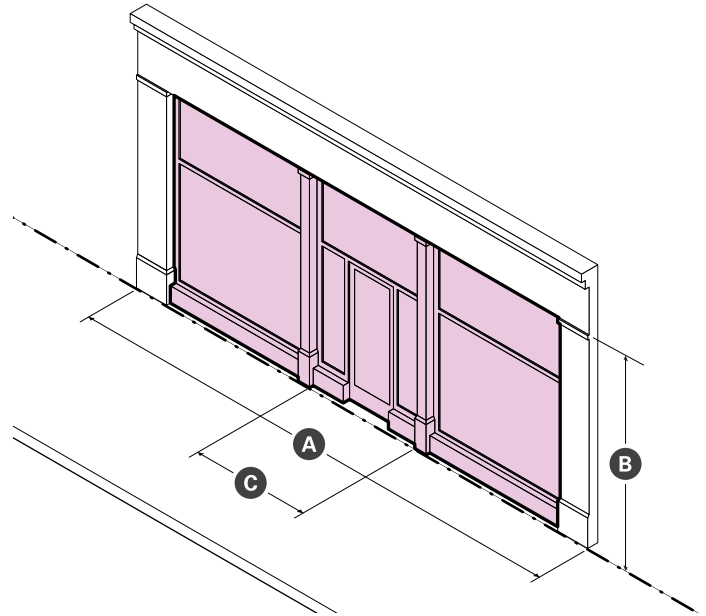

Dimensions		
<b>A</b> Width (min/max)	15 ft	30 ft
<b>B</b> Display Window Height (min)	8 ft	
Recessed Entrance Width (max)	15 ft	
Recessed Entrance Depth (max)	5 ft	

- ii. Standards
  - a). An unobstructed view of the interior space or a lighted and maintained merchandise display(s) must be provided for a depth of at least four (4) feet behind storefront display windows.
  - b). When storefronts are set back from the FRONT LOT LINE, the FRONTAGE AREA must be paved.
  - c). When present, awnings and canopies must be mounted between columns, PILASTERS, OR PIERS; above doorways and display windows; and below the SIGN BAND.
  - d). Exterior security grilles, gates, and roll-down security doors and windows are prohibited.

## 6.0 COMMERCIAL DISTRICTS

Commercial Industry (CI)

### 9. Facade Design

- a. FACADES must provide solid material framing each storefront and lobby entrance as follows:
  - i. PILASTERS or columns supporting a horizontal lintel and CORNICE;
  - ii. a spandrel positioned between PILASTERS or columns that extend from upper stories of the building to the ground; or
  - iii. flat wall above and to either side of a void or punched opening.
- b. Storefronts and lobby entrances must be set within the resulting frame provided for each by the FACADE.
- c. Materials framing each storefront or lobby entrance may be integrated into the design of the FACADE or customized for individual storefronts and lobby entrances. Mechanical louvers necessary for venting purposes are not permitted in the required frame, but may be incorporated into any storefront or lobby entrance system.
- d. FACADES must provide horizontal ARTICULATION or a change in window size or pattern from the upper stories to create a distinct base that includes the entire height of the of the GROUND STORY of the building.
- e. The FACADE of buildings with five (5) or more stories should include, at least, the entire height of the first two (2) stories in the design of the required base. The design of the base may not shift up or down across the

width of the FACADE.

- f. For buildings with more than one FACADE, the design of the base must align horizontally at the corner.
- g. FACADES must provide surface relief from the average plane of the FACADE by at least four (4) inches, through the USE of architectural elements such as bay windows, columns, CORNER BOARDS, CORNICES, door and window surrounds, moldings, PIERS, PILASTERS, recessed storefronts or lobby entrances, seat walls, sills, wall depth, and recessed or projecting windows.

### 10. Architectural Design Guidelines

- i. Reserved

**Figure 5.1.13 Storefront Framing**

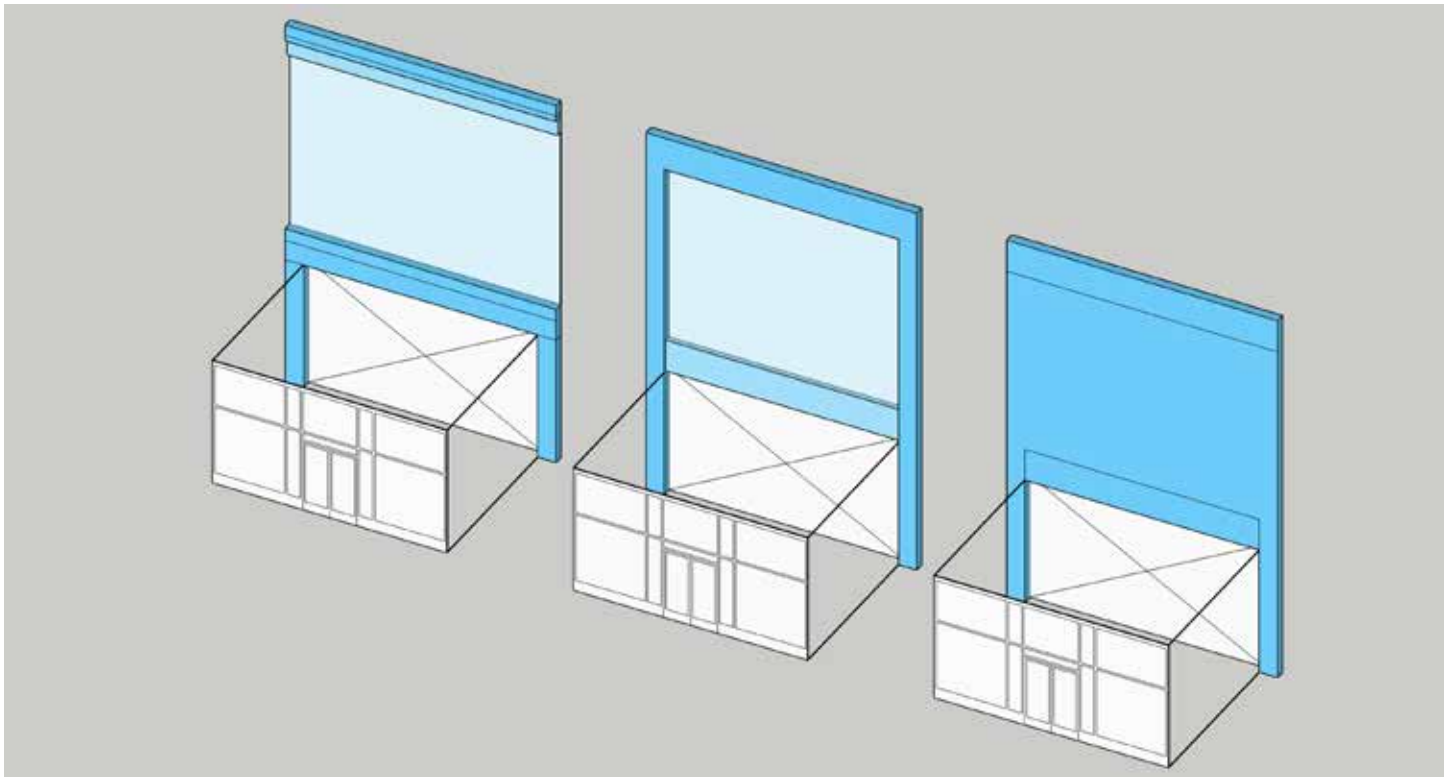

## 11. Use Provisions

- a. General
  - i. The USE of real property is subject to the provisions of Article 9: USE Provisions of this Ordinance. Where the provisions of this section conflict with those of Article 9, the provisions of Article 9 apply.
  - ii. USE categories are permitted according to Table 6.3.11.
  - iii. All USEs must comply with any USE-specific standards applicable for each USE in §9.2 USE Definitions & Limitations.
  - iv. USEs permitted by Special Permit require additional DEVELOPMENT review in accordance with §15.2.1 Special Permits.
  - v. USE categories not identified on Table 6.3.11 are prohibited.

**Table 6.3.11 Permitted Uses**

Use Category Specific Use	CI
<b>Arts &amp; Creative Enterprise</b>	
Artisinal Production	P
Arts Exhibition	P
Arts Sales & Services	P
Co-Working	P
Design Services	P
Shared Workspaces & Arts Education	P
<b>Auto-Oriented</b>	
Commercial Vehicle Repair or Maintenance	SP
Dispatch Service (except as follows)	P
Towing Service	SP
Motor Vehicle Parking (as noted below)	--
Off-Site Accessory Parking	P
Personal Vehicle Repair or Maintenance	SP
Vehicle Sales	SP
<b>Cannabis Establishment</b>	
Cannabis Cultivation	P
Cannabis Product Manufacturing	P
Cannabis Retail Sales	SP
Cannabis Research & Development	P
Cannabis Testing Laboratory	P
<b>Civic &amp; Institutional</b>	
Hospital	SP
Minor Utility Facility	SP
Public Service	P
Religious & Educational Uses Protected by M.G.L. 40A. Sec. 3	P

P - Permitted    SP - Special Permit Required    N - Not Permitted

# 6.0 COMMERCIAL DISTRICTS

Commercial Industry (CI)

**Table 6.3.11 Permitted Uses (continued)**

Use Category Specific Use	CI
<b>Commercial Services</b>	
Animal Services (as noted below)	--
Commercial Kennel	P
Pet Grooming	P
Pet Daycare & Training	P
Veterinarian	P
Assembly or Entertainment	SP
Banking & Financial Services (except as follows)	P
Personal Credit	SP
Broadcast and/or Recording Studio	P
Building & Home Repair Services	P
Business Support Services	P
Caterer/Wholesale Food Production	P
Day Care Service (as noted below)	--
Adult Day Care Center	P
Child Day Care Center	P
Educational Services	P
Maintenance & Repair of Consumer Goods	P
Personal Services (except as follows)	P
Body-Art Services	P
Fitness Services	P
Funeral Services	P
Health Care Services	SP
Formula Personal Services	SP
Recreation Services	P
Vehicle Parking (as noted below)	--
Bike Share Parking	P
Car Share Parking (3 or fewer spaces)	P
Car Share Parking (4 or more spaces)	P
Commercial Parking	P

P - Permitted    SP - Special Permit Required    N - Not Permitted

**Table 6.3.11 Permitted Uses (continued)**

Use Category Specific Use	CI
<b>Food and Beverage Service</b>	
Bar/Restaurant/Tavern	P
Bakery/Café/Coffee Shop	P
Formula Food & Beverage Service	SP
<b>Industrial</b>	
Dry Cleaning or Laundry Services	SP
Data Center	SP
Manufacturing	P
Moving and/or Self Storage (except as follows)	P
Self Storage	SP
Recycling Collection	SP
Trucking and Transportation Depot	SP
Wholesale Trade & Distribution	P
<b>Lodging</b>	
Hotel or Hostel	SP
<b>Office</b>	
General Office	P
Research and Development or Laboratory	P
<b>Retail Sales</b>	
Building/Home Supplies & Equipment	P
Consumer Goods (except as follows)	P
Alcohol Sales	SP
Firearms Sales	N
Pet Store	SP
Formula Retail	SP
Fresh Food Market or Grocery Store	SP
Farm/Vendor Market	P
<b>Urban Agriculture</b>	
Farming (as noted below)	--
Commercial Farming	P
Community Farming	P
Community Gardening	P

P - Permitted    SP - Special Permit Required    N - Not Permitted



**Table 6.3.11 Permitted Uses (continued)**

Use Category Specific Use	CI
<b>Accessory Uses</b>	
Urban Agriculture (as noted below)	--
Commercial Farming	P
<b>Vehicle Parking, Accessory (except as follows)</b>	P
Home Business Vehicle Parking	N

P - Permitted    SP - Special Permit Required    N - Not Permitted

## 12. Development Standards

- a. General
  - i. DEVELOPMENT is subject to the provisions of Article 10 SITE DEVELOPMENT of this Ordinance. Where the provisions of this section conflict with those of Article 10, the provisions of Article 10 apply.
- b. SIGNS
  - i. A SIGN, individual numerals or letters, or a nonelectrical nameplate identifying the property address is required for all real property as follows:
    - a). Each GROUND STORY non-residential USE must identify the STREET address either on the PRINCIPAL ENTRANCE door or above or beside the PRINCIPAL ENTRANCE of the USE.
    - b). All residential BUILDING TYPES must identify the STREET address either on the PRINCIPAL ENTRANCE door, above or beside the PRINCIPAL ENTRANCE, or on a mailbox.
  - ii. Address SIGNS must be made easily visible through the USE of colors or materials that contrast with the background material they are attached to and must be conspicuously located to provide visibility from the THOROUGHFARE that the BUILDING faces.
  - iii. Address SIGNS must be twelve (12) inches in height or less and may include the name of the occupant.

# 6.0 COMMERCIAL DISTRICTS

## Commercial Industry (CI)

### Parking & Mobility

- c. General
  - i. DEVELOPMENT is subject to the provisions of Article 11: Parking & Mobility of this Ordinance. Where the provisions of this section conflict with those of Article 11, the provisions of Article 11 apply.
  - ii. Vehicular parking must be provided as specified on Table 6.3.13, except as follows:
    - a). Non-residential USES with five thousand (5,000) square feet or less of GROSS LEASABLE FLOOR AREA are exempt from any minimum requirements of Table 6.3.13.
    - b). Any CHANGE IN USE within a non-residential STRUCTURE constructed before the effective date of this Ordinance, provided that the change is to a permitted USE, is exempt from any minimum requirements of Table 6.3.13.
  - iii. There are no parking requirements for ACCESSORY USES.
  - iv. MOTOR VEHICLE PARKING spaces may be shared between USES on the same LOT and buildings on the same BLOCK in accordance with §11.3 SHARED PARKING.
- d. Type
  - i. MOTOR VEHICLE PARKING may be provided as SURFACE PARKING, above ground STRUCTURED PARKING, or underground STRUCTURED PARKING.
- e. Driveways
  - i. New driveways require a permit from the City Engineer.
  - ii. Driveways must be compliant with all City Ordinances and constructed in accordance with all standards established by relevant City Departments.
- iii. Driveways are not permitted in the FRONTAGE AREA between a BUILDING and the FRONT LOT LINE.
- iv. Driveways may be no wider than twenty four (24) feet in the FRONTAGE AREA of a LOT.
- v. Driveways may provide ACCESS in whole or in part on or across an ABUTTING LOT(s), provided that an ACCESS EASEMENT exists between all PROPERTY OWNERS.
- f. Parking Design
  - i. The design of all parking is subject to §11.1 Bicycle Parking and §11.2 MOTOR VEHICLE PARKING of this Ordinance.
- g. Parking Location
  - i. Required vehicular parking, excluding any required handicapped parking, may be provided on a contiguous LOT under the same ownership as the LOT that the parking will serve as follows:
    - a). Pedestrian ACCESS to off-SITE vehicular parking must be via a paved sidewalk or walkway.
    - b). A lease, recorded covenant, or other comparable legal instrument guaranteeing long term USE of the SITE must be provided to the review board or BUILDING OFFICIAL and executed and filed with the Registry of Deeds.
  - ii. For real property located in more than one municipality, MOTOR VEHICLE PARKING need not be located within the City of Somerville.
- h. Loading Facilities
  - i. All DEVELOPMENT is exempt from §11.2.5.b.i.
- i. Unbundled Parking
  - i. MOTOR VEHICLE PARKING spaces must be rented or leased as an option rather than a requirement of the rental, lease, or purchase of a DWELLING UNIT OR

**Table 6.3.13 Vehicular Parking**

Use Category Specific Use	BICYCLE		MOTOR VEHICLE	
	Short-Term (min)	Long-Term (min)	Within a TRANSIT AREA <sup>1</sup> (max)	Outside of a TRANSIT AREA <sup>1</sup> (min)
<b>Arts &amp; Creative Enterprise</b>				
All Permitted Uses	1 / 10,000 sf	1 / 3,000 sf	1 / 800 sf	1 / 1,000 sf
<b>Cannabis Establishment</b>				
Cannabis Product Manufacturing	1 / 10,000 sf	1 / 3,000 sf	1 / 800 sf	1 / 1,000 sf
Cannabis Retail Sales	1 / 2,500 sf	1 / 10,000 sf	1 / 1,500 sf	1 / 750 sf
Cannabis Research & Development	1 / 20,000 sf	1 / 5,000 sf	1 / 1,000 sf	1 / 1,000 sf
Cannabis Testing Laboratory	1 / 20,000 sf	1 / 5,000 sf	1 / 1,000 sf	1 / 1,000 sf

sf - Gross Leasable Square Footage

DU - Dwelling Unit RU - Rooming Unit

<sup>1</sup> See the Transit Area Map

**Table 6.3.13 Vehicular Parking (continued)**

Use Category Specific Use	BICYCLE		MOTOR VEHICLE	
	Short-Term (min)	Long-Term (min)	Within a TRANSIT AREA <sup>1</sup> (max)	Outside of a TRANSIT AREA <sup>1</sup> (min)
<b>Civic &amp; Institutional</b>				
Community Center	1 / 10,000 sf	4 / 10,000 sf	1 / 1,800 sf	1 / 600 sf
Educational Facility	1.0 / classroom	4.0 / classroom	1.5 / classroom	3.0 / classroom
Hospital	10 per entrance	1 / 5,000 sf	1 / 200 sf	1 / 1,000 sf
Library	1 / 3,000 sf	1 / 5,000 sf	1 / 800 sf	1 / 500 sf
Minor Utility Facility	n/a	n/a	n/a	n/a
Museum	1 / 2,000 sf	1 / 10,000 sf	1 / 800 sf	1 / 500 sf
Private Non-Profit Club or Lodge	1 / 2,000 sf	1 / 10,000 sf	1 / 200 sf	1 / 1,000 sf
<b>Commercial Services</b>				
Animal Services (as noted below)	–	–	–	–
Commercial Kennel	1 / 2,500 sf	1 / 10,000 sf	1 / 500 sf	1 / 500 sf
Pet Grooming	1 / 2,500 sf	none	1 / 500 sf	1 / 500 sf
Pet Day Care or Training	1 / 2,500 sf	none	1 / 500 sf	1 / 500 sf
Veterinarian	1 / 2,500 sf	1 / 5,000 sf	1 / 500 sf	1 / 500 sf
Assembly or Entertainment	1 / 40 seats	1 / 10,000 sf	1 / 6 seats	1 / 6 seats
Banking & Financial Services (except as noted below)	1 / 2,000 sf	1 / 10,000 sf	1 / 450 sf	1 / 400 sf
Broadcast and/or Recording Studio	1 / 2,500 sf	1 / 10,000 sf	1 / 800 sf	1 / 600 sf
Building & Home Repair Services	1 / 2,500 sf	1 / 10,000 sf	1 / 1,000 sf	1 / 2,000 sf
Business Support Services	1 / 2,500 sf	1 / 10,000 sf	1 / 900 sf	1 / 600 sf
Caterer/Wholesale Food Production	1 / 2,500 sf	1 / 10,000 sf	1 / 800 sf	1 / 1,000 sf
Day Care Service	2	1 / 10,000 sf	1 / 900 sf	1 / 600 sf
Maintenance & Repair of Consumer Goods	1 / 2,500 sf	1 / 10,000 sf	1 / 750 sf	1 / 1,000 sf
Personal Services (except as noted below)	1 / 2,500 sf	1 / 10,000 sf	1 / 750 sf	1 / 1,000 sf
Health Care Services	1 / 2,000 sf	1 / 10,000 sf	1 / 500 sf	1 / 300 sf
Recreation Services	1 / 2,500 sf	1 / 10,000 sf	–	–
<b>Food and Beverage Service</b>				
All Permitted Uses	1 / 1,000 sf	1 / 5,000 sf	1 / 300 sf	1 / 500 sf
<b>Industrial</b>				
Dry Cleaning or Laundry Services	–	–	–	1 / 1,200 sf
Data Center	–	–	–	1 / 1,200 sf

sf - Gross Leasable Square Footage      DU - Dwelling Unit      RU - Rooming Unit

<sup>1</sup> See the Transit Area Map

# 6.0 COMMERCIAL DISTRICTS

Commercial Industry (CI)

**Table 6.3.13 Vehicular Parking (continued)**

Use Category Specific Use	BICYCLE		MOTOR VEHICLE	
	Short-Term (min)	Long-Term (min)	Within a TRANSIT AREA <sup>1</sup> (max)	Outside of a TRANSIT AREA <sup>1</sup> (min)
Manufacturing	--	1 / 10,000 sf	--	1 / 1,200 sf
Moving and/or Self Storage (except as follows)	--	--	--	1 / 1,200 sf
Self Storage	--	--	--	1 / 1,200 sf
Recycling Collection	--	--	--	1 / 1,200 sf
Trucking and Transportation Depot	--	--	--	1 / 1,200 sf
Wholesale Trade & Distribution	--	1 / 40,000 sf	--	1 / 1,200 sf
<b>Lodging</b>				
Bed & Breakfast	1 / 20 rooms	1 / 10 rooms	1 / DU + 1 / 4 guest rooms	1 / DU + 1 / 4 guest rooms
Hotel or Hostel	1 / 20 rooms	1 / 10 rooms	1 / 2 guest rooms	1 / 2 guest rooms
<b>Office</b>				
Co-Working	1 / 20,000 sf	1 / 3,000 sf	1 / 1,200 sf	1 / 800 sf
General Office	1 / 20,000 sf	1 / 3,000 sf	1 / 900 sf	1 / 650 sf
Research and Development or Laboratory	1 / 20,000 sf	1 / 5,000 sf	1 / 1,000 sf	1 / 1,000 sf
<b>Residential</b>				
Household Living	0.1 / DU	1.0 / DU	1.0 / DU	1.0 / DU
Group Living (except as follows)	0.05 / room	0.5 / room	--	--
Community or Group Residence	--	--	--	--
Dormitory, Fraternity or Sorority	0.1 / room	0.5 / room	.05 / bed	1.0 / 4 beds
Homeless Shelter	--	--	4.0	4.0
Nursing Home/Assisted Living Facility	--	--	1 / 6 beds	1 / 6 beds
Single Room Occupancy Housing	--	--	1 / 6 beds	1 / 4 beds
<b>Retail Sales</b>				
Building/Home Supplies & Equipment	1 / 2,500 sf	1 / 10,000 sf	1 / 1,000 sf	1 / 1,000 sf
Consumer Goods (except as follows)	1 / 2,500 sf	1 / 10,000 sf	1 / 1,500 sf	1 / 750 sf
Formula Retail	1 / 2,500 sf	1 / 10,000 sf	1 / 1,500 sf	1 / 750 sf
Fresh Food Market or Grocery Store	1 / 1,000 sf	1 / 10,000 sf	1 / 500 sf	1 / 1,500 sf
Farm/Vendor Market	n/a	n/a	n/a	1 / 1,500 sf

sf - Gross Leasable Square Footage

DU - Dwelling Unit RU - Rooming Unit

<sup>1</sup> See the Transit Area Map

- ii. non-residential floor space.
- ii. Bicycle parking must be provided at no cost or fee to customers, visitors, employees, tenants, and residents.
- j. Parking Relief
  - i. Relief from the parking standards of Table 6.3.13 requires a Special Permit.
    - a). In addition to the review criteria for all Special Permits specified in §15.2.1.e. Review Criteria, the review board shall make findings considering the following in its discretion to approve or deny a special permit authorizing relief from the parking standards of Table 6.3.13:
      - i). The supply and demand of on-STREET parking in the neighborhood, as determined through a parking study.
      - ii). MOBILITY MANAGEMENT programs and services provided by the APPLICANT to reduce the demand for parking.
      - iii). That parking provided in excess of any maximum permitted does not result in the increase in impervious LOT AREA.

### 13. Public Realm

- a. Sidewalk CURB CUTS
  - i. A CURB CUT requires a permit from the City Engineer and must be compliant with all City Ordinances.
  - ii. Unless otherwise specified, the City Engineer may not permit more than two (2) CURB CUTS per FRONT LOT LINE of a LOT.
  - iii. CURB CUTS are prohibited along all THOROUGHFARES designated as a PEDESTRIAN STREET.
  - iv. CURB CUTS must be located to minimize conflicts with pedestrians and bicyclists and must have a clear distance from fire hydrants, STREET TREES, utility poles, and other furnishings as deemed necessary by the City Engineer.
    - a). CURB CUTS should be at least one-hundred (100) feet from an UNSIGNALIZED or SIGNALIZED intersection.
    - b). Multiple CURB CUTS providing ACCESS to the same LOT must be at least one hundred and fifty (150) feet from one another.
  - v. The interior width of a CURB CUT (between curb stones) may be no wider than the driveway, vehicular entrance, or loading facility it serves.
  - vi. A DRIVEWAY APRON may be installed only within the furnishing zone of a sidewalk and must be constructed in accordance with all standards established by relevant City Departments.
  - vii. The grade, cross slope, and clear width of the walkway of a sidewalk must be maintained between the DRIVEWAY APRON and the ABUTTING

**Figure 6.3.14 Sidewalk Curb Cuts**

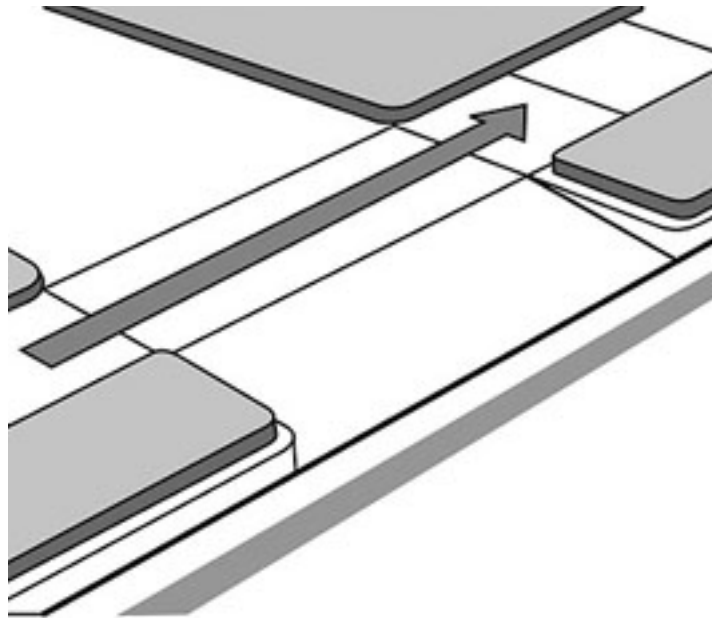

driveway. The appearance of the walkway (ie. scoring pattern or paving material) must indicate that, although a vehicle may cross, the area traversed by a vehicle remains part of the sidewalk.

# 6.0 COMMERCIAL DISTRICTS

Commercial Industry (CI)



## 6.4 COMMERCIAL BUSINESS (CB)

### 1. Character Description

The Commercial Business district is characterized by large FLOOR PLATE buildings up to two (2) stories in height. Buildings are typically SETBACK by large PARKING LOTS and SITES are primarily designed to accommodate automobiles. The district is entirely commercial, with concentrations of commercial services, food & beverage services, and retailers.

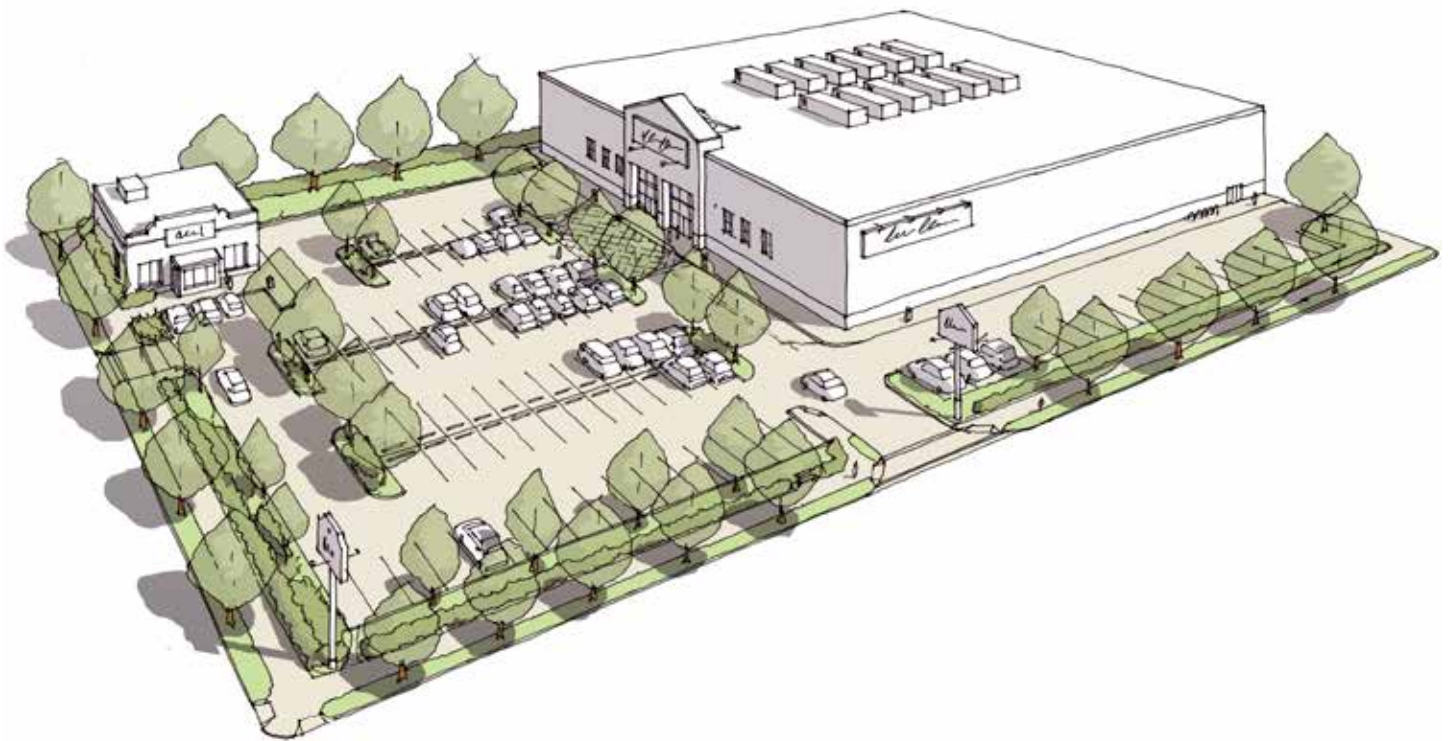

# 6.0 COMMERCIAL DISTRICTS

## Commercial Business (CB)

### 2. Intent

- a. To maintain commercial activities that are primarily ACCESSED by motor vehicles.
- b. To maintain already existing areas appropriate for moderate- and large-scale, low-rise buildings and community- and region-serving commercial USES that do not readily assimilate into other zoning districts.

### 3. Purpose

- a. To permit the DEVELOPMENT of moderate- and large-scale low-rise buildings.
- b. To provide quality commercial spaces and permit commercial USES.

### 4. Applicability

- a. The section is applicable to all real property within the Commercial Business district as shown in the Official Zoning Atlas of the City of Somerville.

### 5. Standards & Measurements

- a. General
  - i. Notwithstanding the defined terms of Article 16: Definitions, the Director of Planning & Zoning shall designate the FACADE of any PRINCIPAL BUILDING TYPE.
  - ii. If such a designation CAUSES a BUILDING to orient away from the THOROUGHFARE its LOT IS ABUTTING, the front and rear SETBACKS are also reoriented.

### 6. Development Review

- a. DEVELOPMENT review is subject to the provisions of Article 15: Administration of this Ordinance.
- b. All DEVELOPMENT, excluding NORMAL MAINTENANCE, requires the submittal of a development review application to the BUILDING OFFICIAL and the issuance of a Certificate of Zoning Compliance prior to the issuance of a BUILDING Permit or Certificate of Occupancy.
- c. Proposed DEVELOPMENT may or may not necessitate the need for SUBDIVISION Plan Approval, Site Plan Approval, a Special Permit, or a Hardship Variance based on the nature of the proposal. In such cases, additional DEVELOPMENT review is required in accordance with Article 15: Administration.
  - i. The Zoning Board of Appeals is the decision making authority for all DEVELOPMENT in the Commercial Business district.
- d. Upon verification that no additional DEVELOPMENT review is necessary, or completion of the required DEVELOPMENT review, the BUILDING OFFICIAL shall issue a Zoning Compliance CERTIFICATE to certify compliance with the

provisions and procedures of this Ordinance.

### 7. Building Types

- a. One (1) PRINCIPAL BUILDING TYPE is permitted on each LOT.
- b. The following BUILDING TYPES are permitted by Site Plan Approval in the HIGH-RISE district:
  - i. Box BUILDING
  - ii. Strip Commerce
  - iii. Pad Commerce
- c. ACCESSORY STRUCTURES are regulated according to Article 10: DEVELOPMENT Standards of this Ordinance.

## 6.4.8. Box Building

A free-standing, low-rise, large FLOOR PLATE, usually single tenant PRINCIPAL BUILDING TYPE that is frequently SETBACK by motor vehicle parking.

The following images are examples of the box BUILDING TYPE and are intended only for illustrative purposes.



# 6.0 COMMERCIAL DISTRICTS

Commercial Business (CB)

## 6.4.8. Box Building (continued)

a. LOT Standards

b. BUILDING Placement

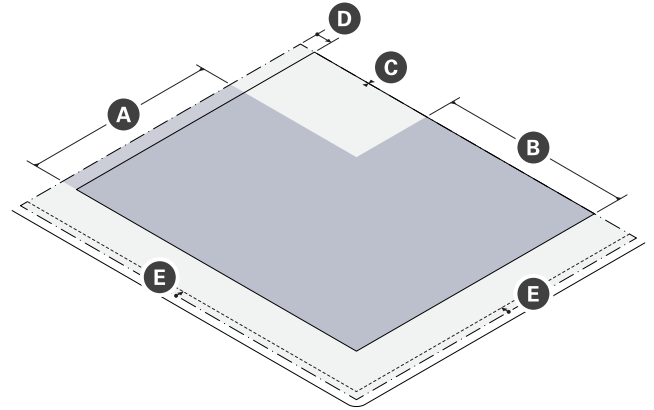
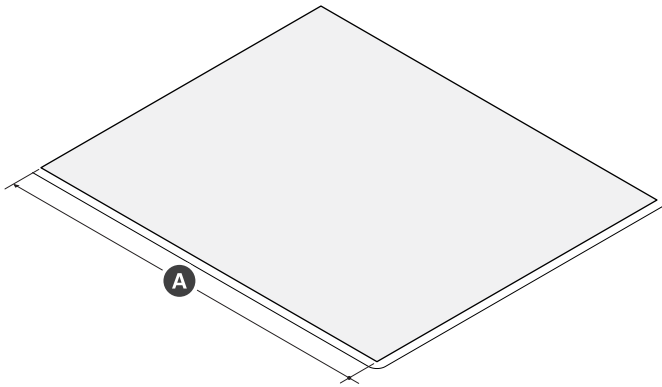

Lot Dimensions	
<b>A</b> Lot WIDTH (max)	800 ft

Lot Development	
<b>B</b> Lot Coverage (max)	75%
<b>C</b> Green Factor (min)	0.20

Building Setbacks		
<b>A</b> Primary Front SETBACK (min/max)	60 ft	300 ft
<b>B</b> Secondary Front SETBACK (min/max)	10 ft	300 ft
<b>C</b> Side SETBACK (min)	0 ft	
Side SETBACK ABUTTING NR or LHD (min)	50 ft	
<b>D</b> Rear SETBACK (min)	20 ft	
Rear SETBACK ABUTTING NR or LHD (min)	50 ft	

Parking Setbacks	
<b>E</b> Front SETBACK (min)	10 ft

## 6.4.8. Box Building (continued)

c. Height & Massing

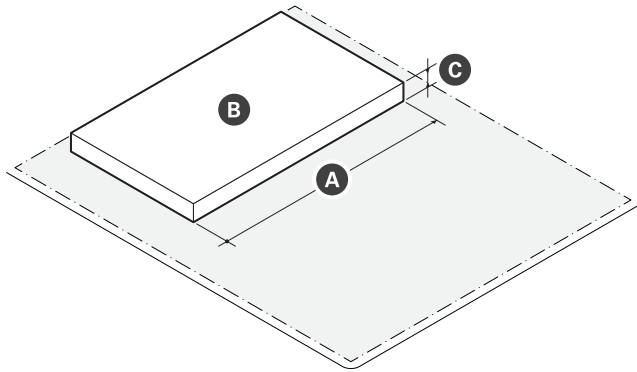

d. Uses & Features

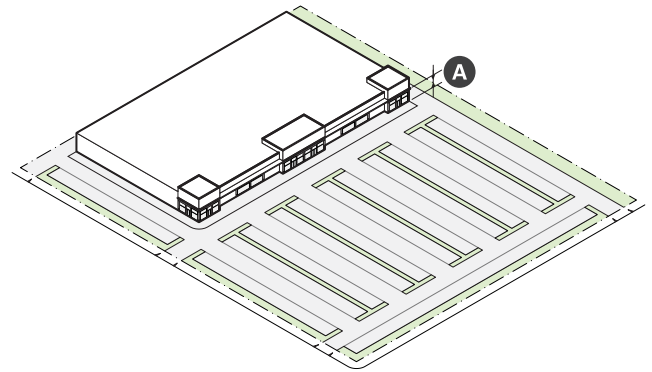

### Main Mass

<b>A</b>	BUILDING WIDTH (max)	400 ft
<b>B</b>	FLOOR PLATE (max)	65,000 sf
<b>C</b>	Number of Stories (max)	1 STORY
	BUILDING Height, Feet (max)	50 ft

### Facade Composition

<b>A</b>	GROUND STORY FENESTRATION (min)	50%
	BLANK WALL (max)	50 ft

### Use & Occupancy

	GROUND STORY Entrance Spacing (max)	200 ft
--	-------------------------------------	--------

# 6.0 COMMERCIAL DISTRICTS

Commercial Business (CB)

## 6.4.8. Box Building (continued)

- e. DEVELOPMENT Benefits
  - i. DEVELOPMENT is subject to the provisions of Article 12: DEVELOPMENT Benefits of this Ordinance. Where the provisions of this section conflict with those of Article 12, the provisions of Article 12 apply.
  - ii. DEVELOPMENT of a box building must provide linkage payments as specified on Table 6.4.8.
- f. Building Design Standards
  - i. Reserved
- g. Architectural Design Guidelines
  - i. Reserved

**Table 6.4.8 Linkage**

<b>Commercial GROSS FLOOR AREA</b>	<b>Affordable Housing Linkage</b>	<b>Employment Linkage</b>
<b>30,000 sf or less</b>	<b>None</b>	<b>None</b>
<b>Over 30,000 sf</b>	<b>\$10/sf</b>	<b>\$2.46/sf</b>



## 6.4.9. Strip Commerce

A low rise, large FLOOR PLATE, multi-tenant BUILDING TYPE that is frequently SETBACK by MOTOR VEHICLE PARKING. Commercial tenants, typically retail or office uses, are oriented side-by-side. Second floors are uncommon, but permitted.

The following images are examples of the strip commerce BUILDING TYPE and are intended only for illustrative purposes.



# 6.0 COMMERCIAL DISTRICTS

Commercial Business (CB)

## 6.4.9. Strip Commerce (continued)

a. LOT Standards

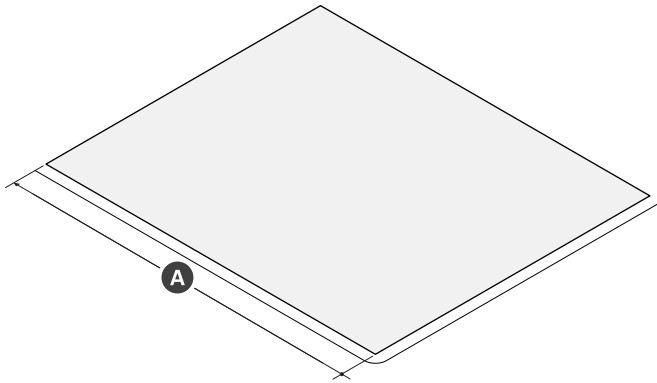

Lot Dimensions	
<b>A</b> Lot WIDTH (max)	400 ft

Lot Development	
<b>B</b> Lot Coverage (max)	75%
<b>C</b> Green Factor (min)	0.20

b. BUILDING Placement

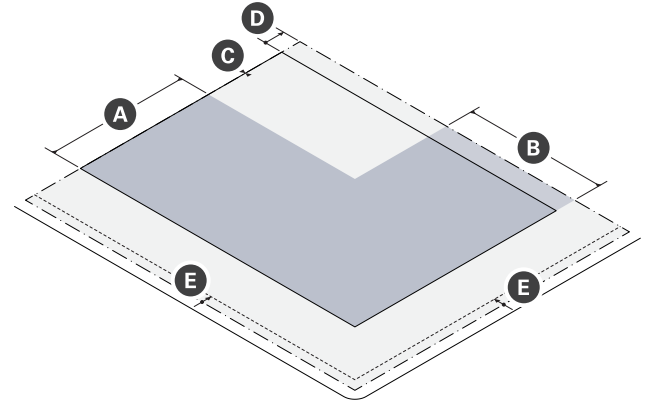

Building Setbacks		
<b>A</b> Primary Front SETBACK (min/max)	60 ft	200 ft
<b>B</b> Secondary Front SETBACK (min/max)	10 ft	200 ft
<b>C</b> Side SETBACK (min)	0 ft	
Side SETBACK ABUTTING NR or LHD (min)	50 ft	
<b>D</b> Rear SETBACK (min)	20 ft	
Rear SETBACK ABUTTING NR or LHD (min)	50 ft	

Parking Setbacks	
<b>E</b> Front SETBACK (min)	10 ft

## 6.4.9. Strip Commerce (continued)

c. Height & Massing

d. Uses & Features

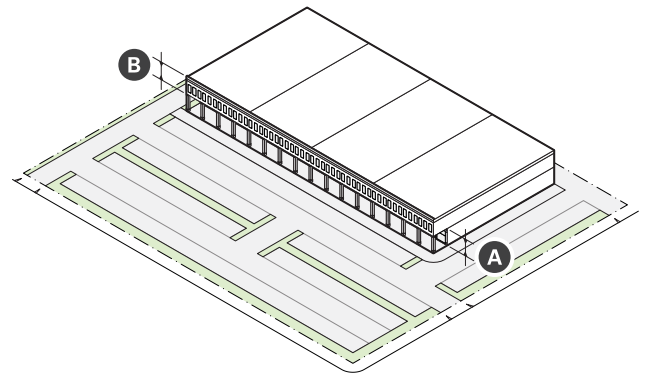
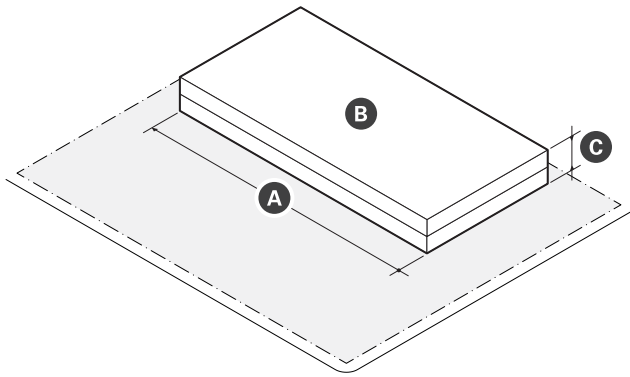

### Main Mass

<b>A</b>	BUILDING WIDTH (max)	400 ft
<b>B</b>	FLOOR PLATE (max)	65,000 sf
<b>C</b>	BUILDING HEIGHT, Stories (max)	2 stories
	BUILDING HEIGHT, Feet (max)	50 ft

### Facade Composition

<b>A</b>	GROUND STORY FENESTRATION (min)	50%
<b>B</b>	UPPER STORY FENESTRATION (min/max)	20%   70%
	BLANK WALL (max)	20 ft

### Use & Occupancy

	GROUND STORY Entrance Spacing (max)	30 ft
	Commercial Space Depth (min)	30 ft

# 6.0 COMMERCIAL DISTRICTS

## Commercial Business (CB)

### 6.4.9. Strip Commerce (continued)

- e. DEVELOPMENT Benefits
  - i. DEVELOPMENT is subject to the provisions of Article 12: DEVELOPMENT Benefits of this Ordinance. Where the provisions of this section conflict with those of Article 12, the provisions of Article 12 apply.
  - ii. DEVELOPMENT of a general building must provide linkage payments as specified on Table 6.4.9.
- f. Building Design Standards
  - i. Reserved
- g. Architectural Design Guidelines
  - i. Reserved

**Table 6.4.9 Linkage**

Floor Area	Affordable Housing Linkage	Employment Linkage
30,000 sf or less	None	None
Over 30,000 sf	\$10/sf	\$2.46/sf



## 6.4.10. Pad Commerce

A low-rise, small FLOOR PLATE, one- to two-tenant BUILDING TYPE on a freestanding LOT typically located in front or to the side of a box BUILDING or strip commerce BUILDING TYPE.

The following images are examples of the pad commerce BUILDING TYPE and are intended only for illustrative purposes.



# 6.0 COMMERCIAL DISTRICTS

Commercial Business (CB)

## 6.4.10. Pad Commerce (continued)

a. LOT Standards

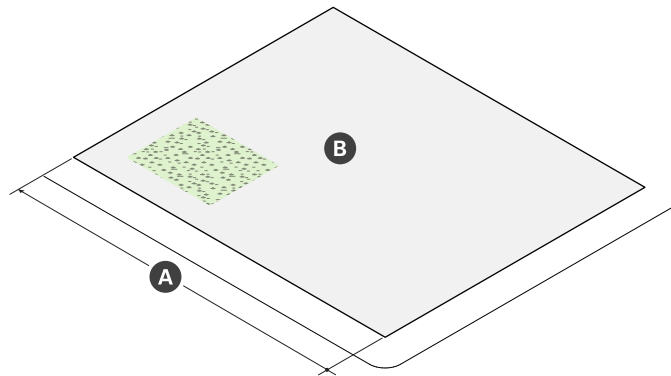

Lot Dimensions	
<b>A</b> Lot WIDTH (max)	250 ft

Lot Development	
Lot Coverage (max)	75%
<b>B</b> Green Factor (min)	0.20

b. BUILDING Placement

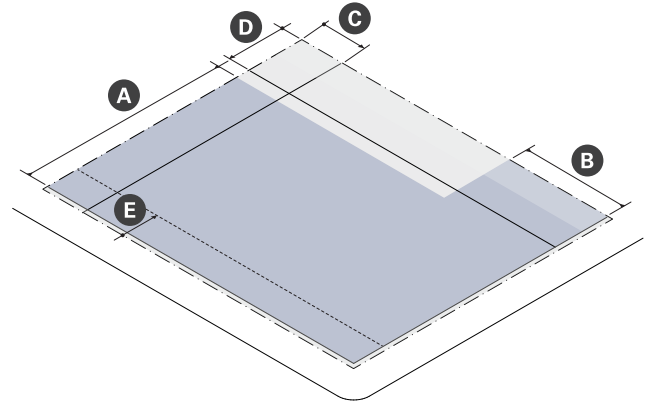

Building Setbacks		
<b>A</b> Primary Front SETBACK (min/max)	2 ft	75 ft
<b>B</b> Secondary Front SETBACK (min/max)	2 ft	40 ft
<b>C</b> Side SETBACK (min)	15 ft	
Side SETBACK ABUTTING NR or LHD (min)	50 ft	
<b>D</b> Rear SETBACK (min)	20 ft	
Rear SETBACK ABUTTING NR or LHD (min)	50 ft	

Parking Setbacks	
<b>E</b> Front SETBACK (min)	10 ft



## 6.4.10. Pad Commerce (continued)

c. Height & Massing

d. Uses & Features

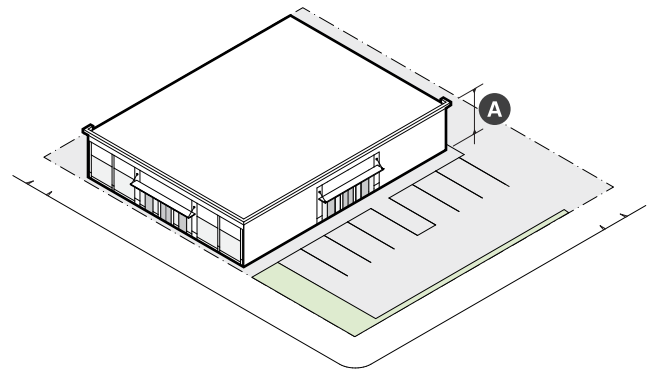
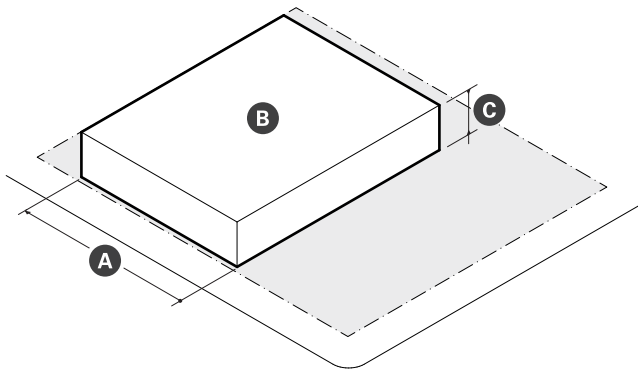

### Main Mass

<b>A</b>	BUILDING WIDTH (max)	100 ft
<b>B</b>	FLOOR PLATE (max)	10,000 sf
<b>C</b>	BUILDING Height, Stories (max)	1 STORY
	BUILDING Height, Feet (max)	25 ft

### Facade Composition

<b>A</b>	GROUND STORY FENESTRATION (min)	70%
	BLANK WALL (max)	20 ft

# 6.0 COMMERCIAL DISTRICTS

## Commercial Business (CB)

### 6.4.10. Pad Commerce (continued)

- e. DEVELOPMENT Benefits
  - i. DEVELOPMENT is subject to the provisions of Article 12: DEVELOPMENT Benefits of this Ordinance. Where the provisions of this section conflict with those of Article 12, the provisions of Article 12 apply.
  - ii. DEVELOPMENT of a general building must provide linkage payments as specified on Table 6.4.10.
- f. Building Design Standards
  - i. Reserved
- g. Architectural Design Guidelines
  - i. Reserved

**Table 6.4.10 Linkage**

Floor Area	Affordable Housing Linkage	Employment Linkage
30,000 sf or less	None	None
Over 30,000 sf	\$10/sf	\$2.46/sf

## 11. Building Components

- a. Building components are ACCESSORY elements attached to the main mass of a building.
- b. Building components are permitted by Site Plan Approval as specified on Table 6.1.8.
  - i. At least one (1) storefront is required for each GROUND STORY commercial space.
- c. Building components not identified on Table 5.1.8 are prohibited.
- d. Unless otherwise specified, BUILDING COMPONENTS may attach to other BUILDING COMPONENTS to create assemblies of components.

**Table 6.1.8 Building Components**

	General Building	Commercial Building	Lab Building	Mid-Rise Podium Tower	Block Building
Awning	P	P	P	P	P
Entry Canopy	P	P	P	P	P
Lobby Entrance	P	P	P	P	P
Storefront	P	P	P	P	P

P - Permitted    SP - Special Permit Required    N - Not Permitted

# 6.0 COMMERCIAL DISTRICTS

## Commercial Business (CB)

### e. Awning

- i. A wall mounted, pitched covering extending from a BUILDING to provide shade and weather protection for pedestrians.

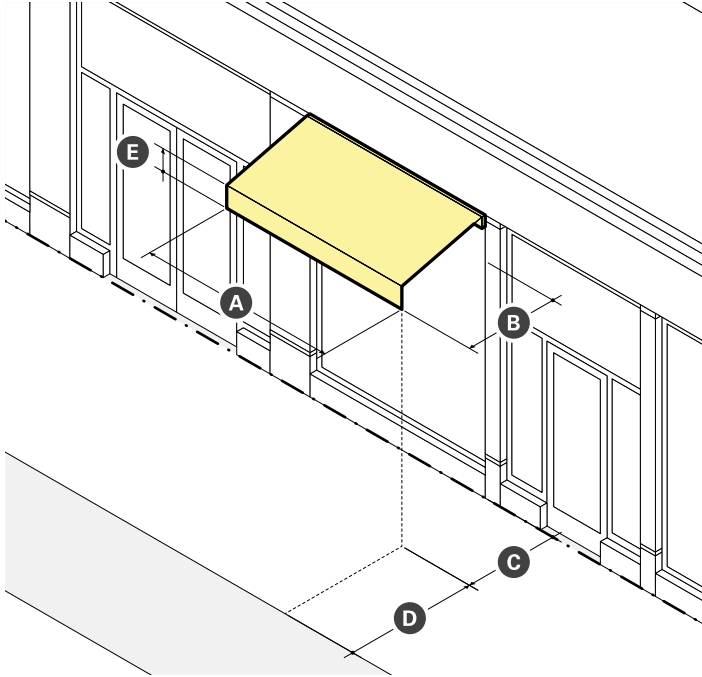

Dimensions	
<b>A</b> Width (min)	See §X
<b>B</b> Projection (min)	3 ft
<b>C</b> CLEARANCE (min)	8 ft clear
<b>D</b> SETBACK from Curb (min)	1.5 ft
<b>E</b> Valance Height (max)	12 in

- ii. Standards
  - a). Awnings must be securely attached to and supported by the BUILDING, and must fit the windows or doors the awning is attached to.
  - b). An awning must be made of durable, weather-resistant material that is water repellent.
  - c). Internally illuminated or back-lit awnings are prohibited.
  - d). An awning that projects over the sidewalk of a public THOROUGHFARE requires compliance with all City Ordinances.

### f. Entry Canopy

- i. An entry canopy is a wall-mounted STRUCTURE that provides shade and weather protection over the entrance of a BUILDING.

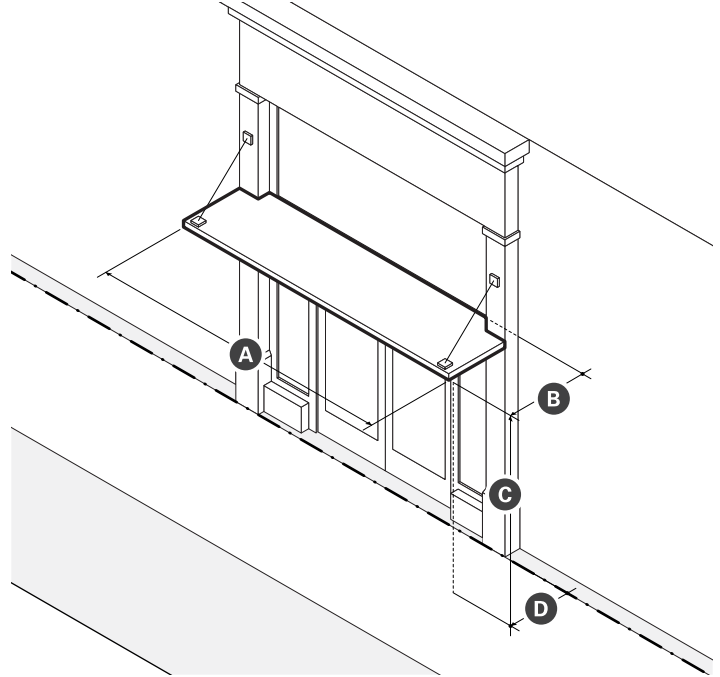

Dimensions	
<b>A</b> Width (min)	See §X
<b>B</b> Depth (max)	3 ft
<b>C</b> CLEARANCE (min)	8 ft clear
<b>D</b> Permitted SETBACK ENCROACHMENT (max)	100%

- ii. Standards
  - a). Entry canopies must be visually supported by brackets, cables, or rods.
  - b). The width of an entry canopy must be equal to or greater than the width of the doorway surround or exterior casing it is mounted over.

## g. Lobby Entrance

- i. A lobby entrance is a non-load bearing assembly of entry doors and windows providing ACCESS and light to the lobby of a BUILDING.

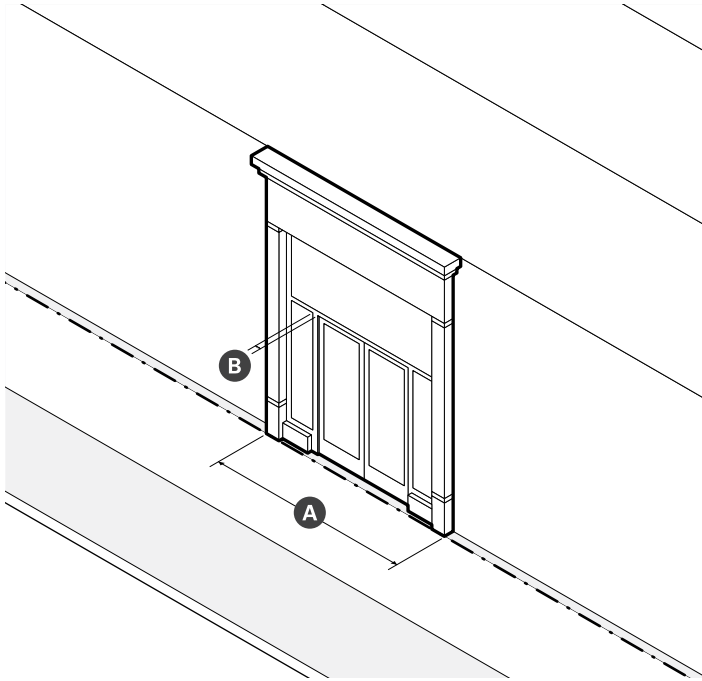

Dimensions		
<b>A</b> Width (min/max)	15 ft	30 ft
Recessed Entrance Width (max)	15 ft	
Recessed Entrance Depth (max)	5 ft	

- ii. Standards
  - a). When a lobby entrance is set back from the FRONT LOT LINE, the FRONTAGE AREA must be paved.

## h. Storefront

- i. A storefront is a non-load bearing assembly of commercial entry doors and windows providing ACCESS and light to a commercial space and a place to display goods, services, and SIGNS.

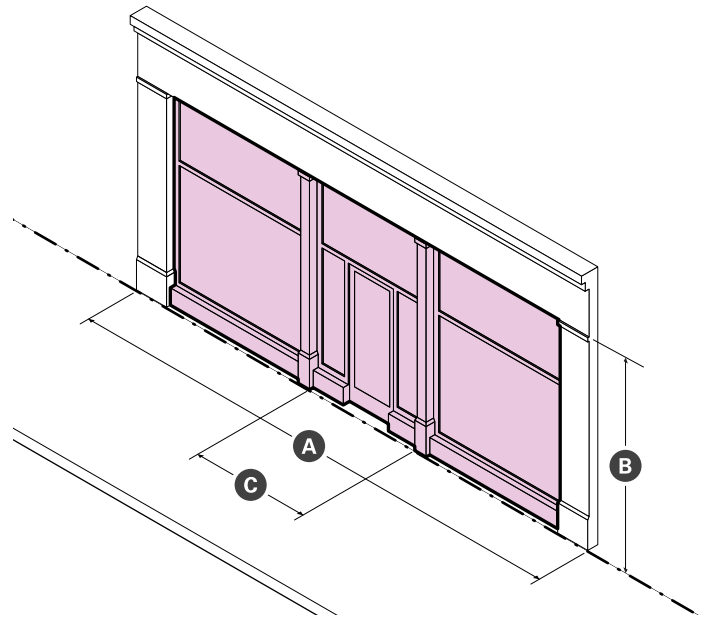

Dimensions		
<b>A</b> Width (min/max)	15 ft	30 ft
<b>B</b> Display Window Height (min)	8 ft	
Recessed Entrance Width (max)	15 ft	
Recessed Entrance Depth (max)	5 ft	

- ii. Standards
  - a). An unobstructed view of the interior space or a lighted and maintained merchandise display(s) must be provided for a depth of at least four (4) feet behind storefront display windows.
  - b). When storefronts are set back from the FRONT LOT LINE, the FRONTAGE AREA must be paved.
  - c). When present, awnings and canopies must be mounted between columns, PILASTERS, OR PIERS; above doorways and display windows; and below the SIGN BAND.
  - d). Exterior security grilles, gates, and roll-down security doors and windows are prohibited.

# 6.0 COMMERCIAL DISTRICTS

## Commercial Business (CB)

### i. Arcade

- i. An arcade is a frontage type featuring a pedestrian walkway covered by the upper floors of a BUILDING. The GROUND STORY FACADE IS SETBACK and upper floors are supported by a colonnade or supports.

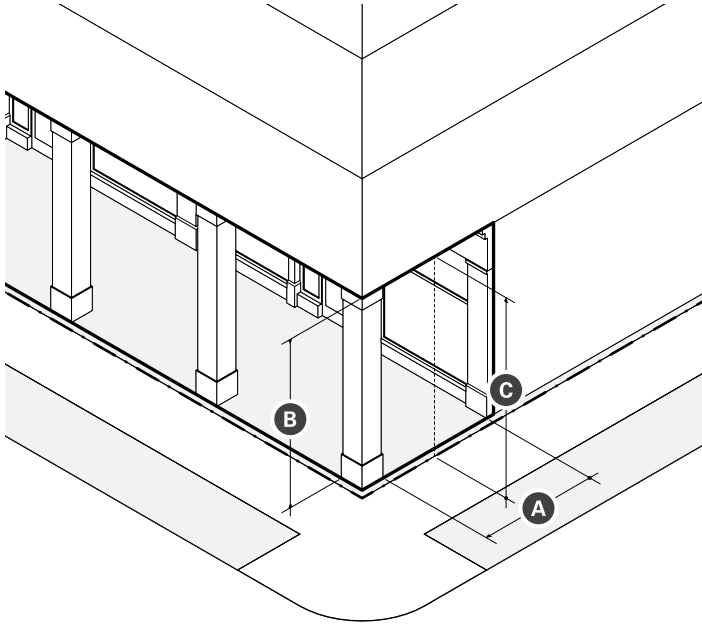

Dimensions		
<b>A</b> Depth (min/max)	10 ft	15 ft
<b>B</b> Height (max)	1 STORY	
<b>C</b> CLEARANCE (min/max)	14 ft	24 ft

- ii. Standards
  - a). Arcades must extend the entire width of a BUILDING and must have a consistent depth.
  - b). Support columns or PIERS may be spaced no farther apart than they are tall.
  - c). Arcades are considered part of the BUILDING for the purpose of measuring FACADE build out.
  - d). Arcades may be combined only with storefront and lobby entrance frontages
  - e). The finished ceiling of an arcade interior may be arched or flat, but must have a greater CLEARANCE than the openings between columns OR PIERS.



## 12. Facade Design

- a. FACADES must provide solid material framing each storefront and lobby entrance as follows:
  - i. PILASTERS or columns supporting a horizontal lintel and CORNICE;
  - ii. a spandrel positioned between PILASTERS or columns that extend from upper stories of the building to the ground; or
  - iii. flat wall above and to either side of a void or punched opening.
- b. Storefronts and lobby entrances must be set within the resulting frame provided for each by the FACADE.
- c. Materials framing each storefront or lobby entrance may be integrated into the design of the FACADE or customized for individual storefronts and lobby entrances. Mechanical louvers necessary for venting purposes are not permitted in the required frame, but may be incorporated into any storefront or lobby entrance system.
- d. FACADES must provide horizontal ARTICULATION or a change in window size or pattern from the upper stories to create a distinct base that includes the entire height of the of the GROUND STORY of the building.
- e. For buildings with more than one FACADE, the design of the base must align horizontally at the corner.
- f. FACADES must provide surface relief from the average plane of the FACADE by at least four (4) inches, through

the USE of architectural elements such as bay windows, columns, CORNER BOARDS, CORNICES, door and window surrounds, moldings, PIERS, PILASTERS, recessed storefronts or lobby entrances, seat walls, sills, wall depth, and recessed or projecting windows.

## 13. Architectural Design Guidelines

- a. Reserved

**Figure 5.1.13 Storefront Framing**

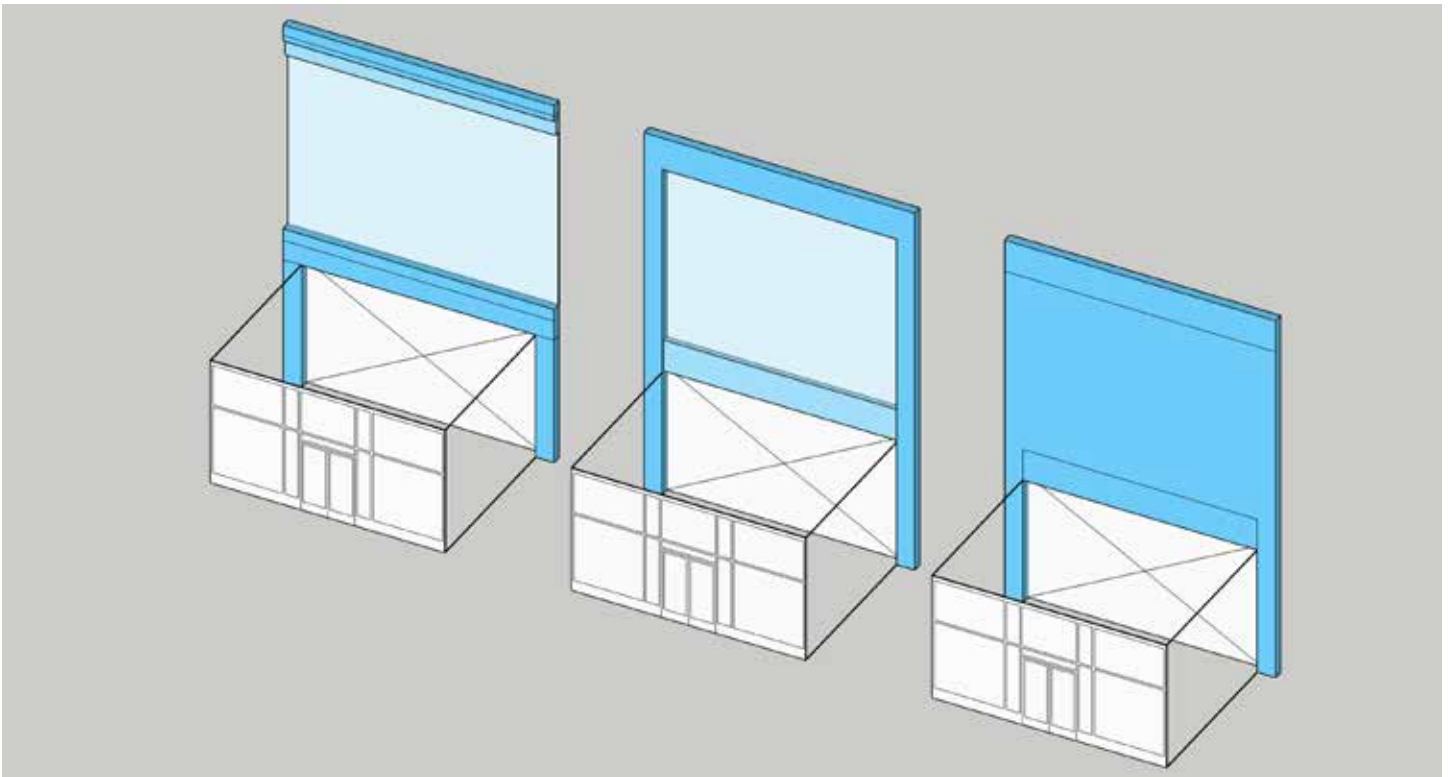

# 6.0 COMMERCIAL DISTRICTS

Commercial Business (CB)

## 14. Use Provisions

- a. Permitted Uses
  - i. The USE of real property is subject to the provisions of Article 9: Use Provisions of this Ordinance. Where the provisions of this section conflict with those of Article 9, the provisions of Article 9 apply.
  - ii. USE categories are permitted as specified on Table 6.4.14.
  - iii. USE categories not identified on Table 6.4.14 are prohibited.
  - iv. All USES must comply with any USE-specific standards applicable for each USE in §9.2 Use Definitions & Limitations.
  - v. USES permitted by Special Permit require additional DEVELOPMENT review in accordance with §15.2.1 Special Permits.
- b. Required Uses
  - i. A minimum of five percent (5%) of the GROSS FLOOR AREA of any Commercial BUILDING or Lab BUILDING must be provided as LEASABLE FLOOR AREA for USES from the Arts & Creative Enterprise USE category.

**Table 6.4 (a) Permitted Uses**

Use Category Specific Use	CB
<b>Arts &amp; Creative Enterprise</b>	
Artisinal Production	P
Arts Exhibition	P
Arts Sales & Services	P
Co-Working	P
Design Services	P
Shared Workspaces & Arts Education	P
<b>Auto-Oriented</b>	
Commercial Vehicle Repair or Maintenance	SP
Dispatch Service (except as follows)	P
Towing Service	SP
Motor Vehicle Parking (as noted below)	--
Off-Site Accessory Parking	P
Personal Vehicle Repair or Maintenance	SP
Vehicle Sales	SP
<b>Cannabis Establishment</b>	
Cannabis Cultivation	P
Cannabis Retail Sales	SP
Cannabis Research & Development	P
Cannabis Testing Laboratory	P
<b>Civic &amp; Institutional</b>	
Minor Utility Facility	SP
Public Service	P
Religious & Educational Uses Protected by M.G.L. 40A. SEc. 3	P

P - Permitted    SP - Special Permit Required    N - Not Permitted

**Table 6.4 (a) Permitted Uses**

Use Category Specific Use	CB
<b>Commercial Services</b>	
<b>Animal Services (as noted below)</b>	--
Commercial Kennel	P
Pet Grooming	P
Pet Day Care or Training	P
Veterinarian	P
<b>Assembly or Entertainment</b>	SP
<b>Banking &amp; Financial Services (except as follows)</b>	P
Personal Credit	SP
<b>Broadcast and/or Recording Studio</b>	P
<b>Building &amp; Home Repair Services</b>	P
<b>Business Support Services</b>	P
<b>Caterer/Wholesale Food Production</b>	P
<b>Day Care Service (as noted below)</b>	--
Adult Day Care Center	P
Child Day Care Center	P
<b>Educational Services</b>	P
<b>Maintenance &amp; Repair of Consumer Goods</b>	P
<b>Personal Services (except as follows)</b>	P
Body-Art Services	P
Fitness Services	P
Funeral Services	P
Health Care Services	SP
Formula Personal Services	SP
<b>Recreation Services</b>	P
<b>Vehicle Parking (as noted below)</b>	--
Bike Share Parking	P
Car Share Parking (3 or less)	P
Car Share Parking (4 or more)	P
Commercial Parking	P

P - Permitted SP - Special Permit Required N - Not Permitted

**Table 6.4 (a) Permitted Uses**

Use Category Specific Use	CB
<b>Food and Beverage Service</b>	
Bar/Restaurant/Tavern	P
Bakery/Café/Coffee Shop	P
Formula Food & Beverage Service	P
<b>Industrial</b>	
<b>Moving and/or Self Storage (except as follows)</b>	N
Self Storage	SP
<b>Lodging</b>	
Hotel or Hostel	SP
<b>Office</b>	
General Office	P
Research and Development or Laboratory	P
<b>Retail Sales</b>	
Building/Home Supplies & Equipment	P
<b>Consumer Goods (except as follows)</b>	P
Alcohol Sales	SP
Firearms Sales	N
Pet Store	SP
Formula Retail	P
Fresh Food Market or Grocery Store	P
Farm/Vendor Market	P
<b>Urban Agriculture</b>	
<b>Farming (as noted below)</b>	--
Commercial Farming	P
Community Farming	P
Community Gardening	P
<b>Accessory Uses</b>	
<b>Urban Agriculture (as noted below)</b>	--
Commercial Farming	P
<b>Vehicle Parking, Accessory (except as follows)</b>	P
Home Business Vehicle Parking	N

P - Permitted SP - Special Permit Required N - Not Permitted

# 6.0 COMMERCIAL DISTRICTS

## Commercial Business (CB)

### 15. Development Standards

- a. General
  - i. DEVELOPMENT is subject to the provisions of Article 10: DEVELOPMENT Standards of this Ordinance. Where the provisions of this section conflict with those of Article 10, the provisions of Article 10 apply.
- b. SIGNS
  - i. A SIGN, individual numerals or letters, or a nonelectrical nameplate identifying the property address is required for all real property as follows:
    - a). Each GROUND STORY non-residential USE must identify the STREET address either on the PRINCIPAL ENTRANCE door or above or beside the PRINCIPAL ENTRANCE of the USE.
    - b). All residential BUILDING TYPES must identify the STREET address either on the PRINCIPAL ENTRANCE door, above or beside the PRINCIPAL ENTRANCE, or on a mailbox.
  - ii. Address SIGNS must be made easily visible through the USE of colors or materials that contrast with the background material they are attached to and must be conspicuously located to provide visibility from the THOROUGHFARE that the BUILDING faces.
  - iii. Address SIGNS must be twelve (12) inches in height or less and may include the name of the occupant.

### 16. Parking & Mobility

- a. General
  - i. DEVELOPMENT is subject to the provisions of Article 11: Parking & Mobility of this Ordinance. Where the provisions of this section conflict with those of Article 11, the provisions of Article 11 apply.
  - ii. Vehicular parking must be provided as specified on Table 6.4.14, except as follows:
    - a). Non-residential USES with five thousand (5,000) square feet or less of gross LEASABLE FLOOR AREA are exempt from any minimum requirements of Table 6.4.14.
    - b). Any CHANGE IN USE within a non-residential STRUCTURE constructed before the effective date of this Ordinance, provided that the change is to a permitted USE, is exempt from any minimum requirements of Table 6.4.14.
  - iii. There are no parking requirements for ACCESSORY USES.
  - iv. MOTOR VEHICLE PARKING spaces may be shared between USES on the same LOT and buildings on the same BLOCK in accordance with §11.3 SHARED PARKING.
- b. Type
  - i. MOTOR VEHICLE PARKING may be provided as SURFACE PARKING, above ground STRUCTURED PARKING, OR underground STRUCTURED PARKING.
- c. Driveways
  - i. New driveways require a permit from the City Engineer.
  - ii. Driveways must be compliant with all City Ordinances and constructed in accordance with all standards established by relevant City Departments.
  - iii. Driveways are not permitted in the FRONTAGE AREA between a BUILDING and the FRONT LOT LINE.
  - iv. Driveways may be no wider than twenty four (24) feet in the FRONTAGE AREA of a LOT.
  - v. Driveways may provide ACCESS in whole or in part on or across an ABUTTING LOT(s), provided that an ACCESS EASEMENT exists between all PROPERTY OWNERS.
- d. Parking Design
  - i. The design of all parking is subject to §11.1 Bicycle Parking and §11.2 MOTOR VEHICLE PARKING of this Ordinance.
- e. Parking Location
  - i. Required vehicular parking, excluding any required handicapped parking, may be provided on a contiguous LOT under the same ownership as the LOT that the parking will serve as follows:
    - a). Pedestrian ACCESS to off-SITE vehicular parking must be via a paved sidewalk or walkway.
    - b). A lease, recorded covenant, or other comparable legal instrument guaranteeing long

**Table 6.4.14 Vehicular Parking**

Use Category Specific Use	BICYCLE		MOTOR VEHICLE	
	Short-Term (min)	Long-Term (min)	Within a TRANSIT AREA <sup>1</sup> (max)	Outside of a TRANSIT AREA <sup>1</sup> (min)
<b>Arts &amp; Creative Enterprise</b>				
All Permitted Uses	1 / 10,000 sf	1 / 3,000 sf	1 / 800 sf	1 / 1,000 sf
<b>Cannabis Establishment</b>				
Cannabis Product Manufacturing	1 / 10,000 sf	1 / 3,000 sf	1 / 800 sf	1 / 1,000 sf
Cannabis Retail Sales	1 / 2,500 sf	1 / 10,000 sf	1 / 1,500 sf	1 / 750 sf
Cannabis Research & Development	1 / 20,000 sf	1 / 5,000 sf	1 / 1,000 sf	1 / 1,000 sf
Cannabis Testing Laboratory	1 / 20,000 sf	1 / 5,000 sf	1 / 1,000 sf	1 / 1,000 sf
<b>Civic &amp; Institutional</b>				
Community Center	1 / 10,000 sf	4 / 10,000 sf	1 / 1,800 sf	1 / 600 sf
Educational Facility	1.0 / classroom	4.0 / classroom	1.5 / classroom	3.0 / classroom
Hospital	10 per entrance	1 / 5,000 sf	1 / 200 sf	1 / 1,000 sf
Library	1 / 3,000 sf	1 / 5,000 sf	1 / 800 sf	1 / 500 sf
Minor Utility Facility	n/a	n/a	n/a	n/a
Museum	1 / 2,000 sf	1 / 10,000 sf	1 / 800 sf	1 / 500 sf
Private Non-Profit Club or Lodge	1 / 2,000 sf	1 / 10,000 sf	1 / 200 sf	1 / 1,000 sf
<b>Commercial Services</b>				
Animal Services (as noted below)	--	--	--	--
Commercial Kennel	1 / 2,500 sf	1 / 10,000 sf	1 / 500 sf	1 / 500 sf
Pet Grooming	1 / 2,500 sf	none	1 / 500 sf	1 / 500 sf
Pet Day Care or Training	1 / 2,500 sf	none	1 / 500 sf	1 / 500 sf
Veterinarian	1 / 2,500 sf	1 / 5,000 sf	1 / 500 sf	1 / 500 sf
<b>Assembly or Entertainment</b>	1 / 40 seats	1 / 10,000 sf	1 / 6 seats	1 / 6 seats
<b>Banking &amp; Financial Services (except as noted below)</b>	1 / 2,000 sf	1 / 10,000 sf	1 / 450 sf	1 / 400 sf
Broadcast and/or Recording Studio	1 / 2,500 sf	1 / 10,000 sf	1 / 800 sf	1 / 600 sf
Building & Home Repair Services	1 / 2,500 sf	1 / 10,000 sf	1 / 1,000 sf	1 / 2,000 sf
Business Support Services	1 / 2,500 sf	1 / 10,000 sf	1 / 900 sf	1 / 600 sf
Caterer/Wholesale Food Production	1 / 2,500 sf	1 / 10,000 sf	1 / 800 sf	1 / 1,000 sf
Day Care Service	2	1 / 10,000 sf	1 / 900 sf	1 / 600 sf
Maintenance & Repair of Consumer Goods	1 / 2,500 sf	1 / 10,000 sf	1 / 750 sf	1 / 1,000 sf
<b>Personal Services (except as noted below)</b>	1 / 2,500 sf	1 / 10,000 sf	1 / 750 sf	1 / 1,000 sf
Health Care Services	1 / 2,000 sf	1 / 10,000 sf	1 / 500 sf	1 / 300 sf

sf - Gross Leasable Square Footage      DU - Dwelling Unit      RU - Rooming Unit

<sup>1</sup> See the Transit Area Map

# 6.0 COMMERCIAL DISTRICTS

Commercial Business (CB)

**Table 6.4.14 Vehicular Parking (continued)**

Use Category Specific Use	BICYCLE		MOTOR VEHICLE	
	Short-Term (min)	Long-Term (min)	Within a TRANSIT AREA <sup>1</sup> (max)	Outside of a TRANSIT AREA <sup>1</sup> (min)
<b>Recreation Services</b>	1 / 2,500 sf	1 / 10,000 sf	--	--
<b>Food and Beverage Service</b>				
Bar/Restaurant/Tavern	1 / 1,000 sf	1 / 5,000 sf	1 / 300 sf	1 / 500 sf
Bakery/Café/Coffee Shop	1 / 1,000 sf	1 / 5,000 sf	1 / 300 sf	1 / 500 sf
Formula Food & Beverage Service	1 / 1,000 sf	1 / 5,000 sf	1 / 300 sf	1 / 500 sf
<b>Lodging</b>				
Bed & Breakfast	1 / 20 rooms	1 / 10 rooms	1 / DU + 1 / 4 guest rooms	1 / DU + 1 / 4 guest rooms
Hotel or Hostel	1 / 20 rooms	1 / 10 rooms	1 / 2 guest rooms	1 / 2 guest rooms
Short Term Rental	1 / 20 rooms	1 / 10 rooms	n/a	n/a
<b>Office</b>				
Co-Working	1 / 20,000 sf	1 / 3,000 sf	1 / 1,200 sf	1 / 800 sf
General Office	1 / 20,000 sf	1 / 3,000 sf	1 / 900 sf	1 / 650 sf
Research and Development or Laboratory	1 / 20,000 sf	1 / 5,000 sf	1 / 1,000 sf	1 / 1,000 sf
<b>Residential</b>				
Household Living	0.1 / DU	1.0 / DU	1.0 / DU	1.0 / DU
<b>Group Living (except as follows)</b>	0.05 / room	0.5 / room	--	--
Community or Group Residence	--	--	--	--
Dormitory, Fraternity or Sorority	0.1 / room	0.5 / room	.05 / bed	1.0 / 4 beds
Homeless Shelter	--	--	4.0	4.0
Nursing Home/Assisted Living Facility	--	--	1 / 6 beds	1 / 6 beds
Single Room Occupancy Housing	--	--	1 / 6 beds	1 / 4 beds
<b>Retail Sales</b>				
Building/Home Supplies & Equipment	1 / 2,500 sf	1 / 10,000 sf	1 / 1,000 sf	1 / 1,000 sf
Consumer Goods (except as follows)	1 / 2,500 sf	1 / 10,000 sf	1 / 1,500 sf	1 / 750 sf
Formula Retail	1 / 2,500 sf	1 / 10,000 sf	1 / 1,500 sf	1 / 750 sf
Fresh Food Market or Grocery Store	1 / 1,000 sf	1 / 10,000 sf	1 / 500 sf	1 / 1,500 sf
Farm/Vendor Market	n/a	n/a	n/a	1 / 1,500 sf

sf - Gross Leasable Square Footage

DU - Dwelling Unit RU - Rooming Unit

<sup>1</sup> See the Transit Area Map



term USE OF THE SITE must be provided to the review board or BUILDING OFFICIAL and executed and filed with the Registry of Deeds.

- ii. For real property located in more than one municipality, MOTOR VEHICLE PARKING need not be located within the City of Somerville.
- f. Unbundled Parking
  - i. MOTOR VEHICLE PARKING spaces must be rented or leased as an option rather than a requirement of the rental, lease, or purchase of a DWELLING UNIT OR non-residential floor space.
  - ii. Bicycle parking must be provided at no cost or fee to customers, visitors, employees, tenants, and residents.
- g. Parking Relief
  - i. Relief from the parking standards of Table 6.4.14 requires a Special Permit.
    - a). In addition to the review criteria for all Special Permits specified in §15.2.1.e. Review Criteria, the review board shall make findings considering the following in its discretion to approve or deny a special permit authorizing relief from the parking standards of Table 4.4 (d):
      - i). The supply and demand of on-STREET parking in the neighborhood, as determined through a parking study.
      - ii). MOBILITY MANAGEMENT programs and services provided by the APPLICANT to reduce the demand for parking.
      - iii). That parking provided in excess of any maximum permitted does not result in the increase in impervious LOT AREA.

## 17. Public Realm

- a. Sidewalk CURB CUTS
  - i. A CURB CUT requires a permit from the City Engineer and must be compliant with all City Ordinances.
  - ii. Unless otherwise specified, the City Engineer may not permit more than one (1) CURB CUT per FRONT LOT LINE of a LOT.
  - iii. CURB CUTS are prohibited along all THOROUGHFARES designated as a PEDESTRIAN STREET.
  - iv. CURB CUTS must be located to minimize conflicts with pedestrians and bicyclists and must have a clear distance from fire hydrants, STREET TREES, utility poles, and other furnishings as deemed necessary by the City Engineer.
    - a). CURB CUTS should be at least one-hundred (100) feet from an UNSIGNALIZED or SIGNALIZED intersection.
    - b). Multiple CURB CUTS providing ACCESS to the same LOT must be at least one hundred and fifty (150)

**Figure 6.4.15 Sidewalk Curb Cuts**

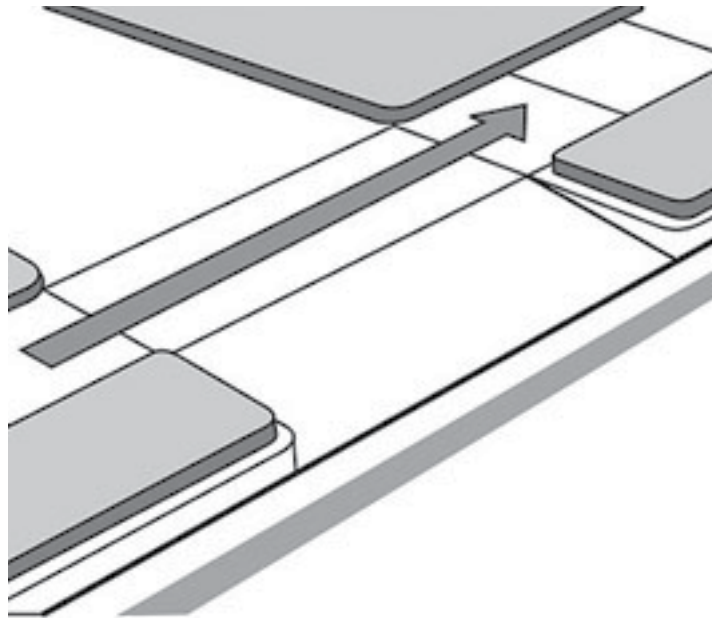

- feet from one another.
- v. The interior width of a CURB CUT (between curb stones) may be no wider than the driveway, vehicular entrance, or loading facility it serves.
- vi. A DRIVEWAY APRON may be installed only within the furnishing zone of a sidewalk and must be constructed in accordance with all standards established by relevant City Departments.
- vii. The grade, cross slope, and clear width of the walkway of a sidewalk must be maintained between the DRIVEWAY APRON and the ABUTTING driveway. The appearance of the walkway (ie. scoring pattern or paving material) must indicate that, although a vehicle may cross, the area traversed by a vehicle remains part of the sidewalk.

# 6.0 COMMERCIAL DISTRICTS

Commercial Business (CB)

# 7 SPECIAL DISTRICTS

<b>7.1</b>	<b>CIVIC (CIV)</b> .....	<b>357</b>	<b>7.4</b>	<b>ASSEMBLY SQUARE MIXED-USE (ASMD)</b> .....	<b>371</b>
	Character Description	357		Description	371
	Intent	358		Intent	372
	Purpose	358		Purpose	372
	Applicability	358		Applicability	372
	Development Review	358		Development Review	372
	Use Provisions	358		Master Plan Standards	373
	Development Standards	358		Building Standards	373
	Parking & Mobility	358		Use Provisions	375
	Public Realm	358		DEVELOPMENT Standards	377
<b>7.2</b>	<b>POWDERHOUSE SCHOOL (PS)</b> .....	<b>359</b>		Parking & Mobility	378
	Character Description	359		DEVELOPMENT Benefits	378
	Intent	360		Public Realm	379
	Purpose	360		Land Platting	379
	Applicability	360			
	Development Review	360			
	Building Standards	360			
	Use Provisions	360			
	Development Standards	362			
	Parking & Mobility	362			
	Development Benefits	362			
	Public Realm	363			
<b>7.3</b>	<b>TUFTS UNIVERSITY (TU)</b> .....	<b>365</b>			
	Character Description	365			
	Intent	366			
	Purpose	366			
	Applicability	366			
	Development Review	366			
	Lots	366			
	Building Standards	366			
	Use Provisions	369			
	Parking & Mobility	369			



## 7.1 CIVIC (CIV)

### 1. Character Description

The Civic district is characterized by public spaces, such as parks, commons, and plazas, and buildings dedicated to arts, culture, education, recreation, and local government that serve as necessary components of any community. Buildings are distinctive in their placement, orientation, and design and occupy prominent locations that reinforce community identity.



# 7 SPECIAL DISTRICTS

## Civic (CIV)

### 2. Intent

- To implement the objectives of the COMPREHENSIVE PLAN of the City of Somerville.
- To preserve already established SITES as CIVIC SPACE.
- To accommodate facilities of a public nature such as municipal buildings, libraries, and police & fire stations; governmental uses; and public or private utility services that support the community.

### 3. Purpose

- To permit the DEVELOPMENT of buildings that serve a public purpose for the community.
- To permit the DEVELOPMENT of CIVIC SPACES throughout the city.
- The permit DEVELOPMENT by Site Plan Approval so that any impacts to ABUTTING properties can be properly mitigated.

### 4. Applicability

- The section is applicable to all real property within the Civic district as shown on the maps of the Official Zoning Atlas of the City of Somerville.

### 5. Development Review

- DEVELOPMENT review is subject to the provisions of Article 15: Administration of this Ordinance.
- All DEVELOPMENT, excluding NORMAL MAINTENANCE, requires the submittal of a development review application to the BUILDING OFFICIAL and the issuance of a Certificate of Zoning Compliance prior to the issuance of a BUILDING Permit, Construction Permit, or Certificate of Occupancy.
- Proposed DEVELOPMENT may or may not necessitate the need for Subdivision Plan Approval, Subdivision Plan Approval, Site Plan Approval, a Special Permit, or a Hardship Variance based on the nature of the proposal. In such cases, additional DEVELOPMENT review is required in accordance with Article 15: Administration.
  - The Planning Board is the decision making authority for all DEVELOPMENT that requires a Special Permit.
  - The Zoning Board of Appeals is the Review Board for all HardSHIP Variances.
- Upon verification that no additional DEVELOPMENT review is necessary, or completion of the required DEVELOPMENT review, the BUILDING OFFICIAL shall issue a Zoning Compliance Certificate to certify compliance with the provisions and procedures of this Ordinance.

### 6. Use Provisions

- Permitted Uses
  - The USE of real property is subject to the provisions of Article 9: Use Provisions of this Ordinance. Where the provisions of this section conflict with

**Table 7.1.7 Permitted Uses**

Use Category Specific Use	CIV
<b>Civic &amp; Institutional</b>	
MINOR UTILITY FACILITY	SP
<b>Public Services</b>	P
<b>Religious &amp; Educational Uses Protected by M.G.L. 40A. Sec. 3</b>	P
<b>Commercial Services</b>	
<b>Recreation Services</b>	P
<b>Vehicle Parking (as noted below)</b>	--
Bike Share Parking	P
Car Share Parking (3 or less)	N
Car Share Parking (4 or more)	N
COMMERCIAL PARKING	N
<b>Urban Agriculture</b>	
<b>Farming (as noted below)</b>	--
Commercial Farming	N
Community Farming	P
<b>Community Gardening</b>	P

- those of Article 9, the provisions of Article 9 apply.
- USE categories are permitted as specified on Table 7.1.6. (a).
- USE categories that are not identified on Table 7.1.6. (a) are prohibited.
- All USES must comply with any USE-specific standards applicable for each USE in §9.2 Use Definitions & Limitations.
- USES permitted by Special Permit require additional DEVELOPMENT review in accordance with §15.2.1 Special Permits.

### 7. Development Standards

- DEVELOPMENT is exempt from Article 10: DEVELOPMENT Standards of this Ordinance.

### 8. Parking & Mobility

- DEVELOPMENT is exempt from Article 11: Parking and Mobility of this Ordinance.

### 9. Public Realm

- CIVIC SPACES existing prior to the adoption date of this Ordinance are exempt from Article 13: PUBLIC REALM of this Ordinance.



## 7.2 POWDERHOUSE SCHOOL (PS)

### 1. Character Description

The Powderhouse School district is characterized by the adaptation and re-use of a former school into a mixed-use COURTYARD BUILDING. Ground level and garden level commercial uses address the needs of residents and neighbors in the immediate neighborhood and encourage activation of the adjacent CIVIC SPACE. Residential uses include a variety of unit types, sizes, BEDROOM counts, and affordability.



# 7 SPECIAL DISTRICTS

Powderhouse School (PS)

## 2. Intent

- a. To accommodate reDEVELOPMENT the former Powderhouse Community School as an inclusive and diverse mix of complimentary urban USES and intergenerational housing options that is respectful of the surrounding neighborhood.

## 3. Purpose

- a. To permit the reDEVELOPMENT reUSE of the former Powderhouse Community School.
- b. To require a minimum amount of commercial activity fronting onto Broadway.
- c. To USE discretion in the permitting of residential USES.

## 4. Applicability

- a. The section is applicable to all real property within the Powderhouse School ReDEVELOPMENT district as shown on the maps of the Official Zoning Atlas of the City of Somerville.
- b. Unless otherwise specified, where the provisions of this Section conflict with those found elsewhere in this Ordinance, the provisions of this Section apply.

## 5. Development Review

- a. DEVELOPMENT review is subject to the provisions of Article 15: Administration of this Ordinance.
- b. All DEVELOPMENT, excluding NORMAL MAINTENANCE, requires the submittal of a development review application to the BUILDING OFFICIAL and the issuance of a Certificate of Zoning Compliance prior to the issuance of a BUILDING Permit, Construction Permit, or Certificate of Occupancy.
- c. Proposed DEVELOPMENT may or may not necessitate the need for SUBDIVISION Plan Approval, Site Plan Approval, a Special Permit, or a Hardship Variance based on the nature of the proposal. In such cases, additional DEVELOPMENT review is required in accordance with Article 15: Administration.
  - i. The Planning Board is the decision making authority for all DEVELOPMENT that requires Site Plan Approval or a Special Permit.
  - ii. The Zoning Board of Appeals is the Review Board for all HardSHIP Variances.
- d. Upon verification that no additional DEVELOPMENT review is necessary, or completion of the required DEVELOPMENT review, the BUILDING OFFICIAL shall issue a Zoning Compliance CERTIFICATE to certify compliance with the provisions and procedures of this Ordinance.

## 6. Building Standards

- a. Construction or reconstruction of a PRINCIPAL BUILDING is permitted by Site Plan Approval in accordance with Table 7.2.6 Dimensional Standards.
- b. ACCESSORY STRUCTURES are regulated according to Article 10: DEVELOPMENT Standards of this Ordinance.

**Table 7.2.6 Dimensional Standards**

LOT AREA/DWELLING UNIT (min.)	1,000 sq. ft. (43.56/acre)
Maximum Height, Stories (max.)	3
Maximum Height, Feet (max.)	50 ft.
Maximum GROUND COVERAGE (max.)	95%
Landscaped Area (min.)	15%
PERVIOUS AREA (min.)	5%

## 7. Use Provisions

- a. General
  - i. The USE of real property is subject to the provisions of Article 9.0 Use Provisions of this Ordinance. Where the provisions of this section conflict with those of Article 9.0, the provisions of Article 4.0 apply.
  - ii. USE categories are permitted as specified on Table 7.2.7 Permitted USES.
  - iii. USE categories not identified on Table 7.4.7 are prohibited.
  - iv. All USES must comply with any USE-specific standards applicable for each USE in §9.2 Use Definitions & Limitations.
  - v. USES permitted by Special Permit require additional DEVELOPMENT review in accordance with §15.2.1 Special Permits.
- b. Required USES
  - i. A minimum of ten thousand (10,000) gross square feet must be provided as one or more commercial USES.
  - ii. Commercial space must front onto Broadway for a minimum of one hundred (100) feet in width.

**Table 7.2.7 Permitted Uses**

Use Category Specific Use	PSR
<b>Arts &amp; Creative Enterprise</b>	
ARTISINAL PRODUCTION	P
ARTS EXHIBITION	P
Arts Sales & Services	P
<b>Civic &amp; Institutional</b>	
COMMUNITY CENTER	P
LIBRARY	P
MINOR UTILITY FACILITY	P
MUSEUM	P
Public Service	P
Religious & Educational Uses Protected by M.G.L. 40A. Sec. 3	P
<b>Commercial Services</b>	
ASSEMBLY OR ENTERTAINMENT	P
<b>Day Care Service (as noted below)</b>	--
ADULT DAY CARE CENTER	P
CHILD DAY CARE CENTER	P
<b>Maintenance &amp; Repair of CONSUMER GOODS</b>	P
PERSONAL SERVICES (except as follows)	P
Body-Art Services	SP
Fitness Services	P
Funeral Services	N
Health Care Services	SP
Formula Personal Services	SP
<b>Vehicle Parking (except as follows)</b>	--
Bike Share Parking	P
Car Share Parking (3 or less)	P
Car Share Parking (4 or more)	P
Public Parking	P

P - Permitted SP - Special Permit Required N - Not Permitted

**Table 7.2.7 Permitted Uses**

Use Category Specific Use	PSR
<b>Food and Beverage Service</b>	
Bar/Restaurant/Tavern	SP
Bakery/Café/Coffee Shop	P
<b>Office</b>	
GENERAL OFFICE	P
Research and DEVELOPMENT and Laboratory	P
<b>Residential</b>	
HOUSEHOLD LIVING	SP
GROUP LIVING (except as follows)	SP
COMMUNITY OR GROUP RESIDENCE	P
DORMITORY OR CHAPTER HOUSE	N
HOMELESS SHELTER	N
Nursing Home/Assisted Living Facility	N
Rooming House	N
<b>Retail Sales</b>	
CONSUMER GOODS (except as follows)	P
ALCOHOL SALES	P
FIREARMS SALES	N
PET STORE	SP
FRESH FOOD MARKET OR GROCERY STORE	P
<b>Urban Agriculture</b>	
FARMING (as noted below)	--
COMMERCIAL FARMING	P
COMMUNITY FARMING	P
COMMUNITY GARDENING	P

P - Permitted SP - Special Permit Required N - Not Permitted

# 7 SPECIAL DISTRICTS

Powderhouse School (PS)

**Table 7.2.7 Permitted Uses**

Use Category Specific Use	PSR
<b>ACCESSORY USES</b>	
<b>HOME OCCUPATIONS (as noted below)</b>	--
CREATIVE STUDIO	P
HOBBY KENNEL	N
HOME-BASED BUSINESS	P
Home Day Care	P
HOME OFFICE	P
<b>Tourist Home</b>	P
<b>Urban Agriculture (as noted below)</b>	--
APICULTURE	P
AVICULTURE	P
COMMERCIAL FARMING	P
Residential Gardening	P
<b>Vehicle Parking, Accessory (except as follows)</b>	N
Home Business Vehicle Parking	N

P - Permitted SP - Special Permit Required N - Not Permitted

## 8. Development Standards

- a. General
  - i. DEVELOPMENT is subject to the provisions of Article 10: DEVELOPMENT Standards Standards of this Ordinance. Where the provisions of this section conflict with those of Article 10, the provisions of Article 10 apply.
  - ii. All storage, dumpsters, and mechanical equipment must be located within the building. Air conditioners may be located on the roof(s).
- b. SIGNS
  - i. A SIGN, individual numerals or letters, or a nonelectrical nameplate identifying the property address is required for all real property as follows:
    - a). Each GROUND STORY non-residential USE must identify the STREET address either on the PRINCIPAL ENTRANCE door or above or beside the PRINCIPAL ENTRANCE of the USE.
    - b). All residential BUILDING TYPES must identify the STREET address either on the PRINCIPAL ENTRANCE door, above or beside the PRINCIPAL ENTRANCE, OR on a mailbox.
  - ii. Address SIGNS must be made easily visible through the USE of colors or materials that contrast with the background material they are attached to and must be conspicuously located to provide visibility from

the THOROUGHFARE that the building faces.

- iii. Address SIGNS must be twelve (12) inches in height or less and may include the name of the occupant.

## 9. Parking & Mobility

- a. General
  - i. DEVELOPMENT is subject to the provisions of Article 11: Parking & Mobility of this Ordinance.
  - ii. The total parking requirement in the PS district is as follows:
    - a). A minimum of forty-eight (48) motor vehicle parking spaces must be provided on-SITE.
    - b). A minimum of one hundred (100) bicycle parking spaces must be provided on-SITE.
- b. Parking Type
  - i. Motor vehicle parking may be provided as above ground STRUCTURED PARKING or underground STRUCTURED PARKING.
- c. Parking Design
  - i. Bicycle and motor vehicle parking is subject to §11.1 Parking Design of this Ordinance except as follows:
    - a). Parking spaces may have a minimum width of seven (7) feet six (6) inches.
    - b). Two (2) way maneuvering aisles may have a minimum width of eighteen (18) feet.
- d. Loading Facilities
  - i. Loading facilities are not required for any USES.

## 10. Development Benefits

- a. DEVELOPMENT is subject to the provisions of Article 12: DEVELOPMENT Benefits of this Ordinance. Where the provisions of this section conflict with those of Article 12, the provisions of Article 12 apply.
- b. DEVELOPMENT must provide AFFORDABLE DWELLING UNITS as specified on Table 7.4.10 (a).

**Table 7.4.10 (a) Required ADUs**

Total DWELLING UNITS	Required ADUs
0 to 5 units	None
6 units	1 unit OR fractional buyout for 0.4 units
7 units	1 unit OR fractional buyout for 0.6 units
8 to 17 units	17.5% of units
18 or more units	20% of units

**11. Public Realm**

- a. General
  - i. DEVELOPMENT is subject to the provisions of Article 13: PUBLIC REALM of this Ordinance. Where the provisions of this section conflict with those of Article 13, the provisions of Article 13 apply.
- b. Sidewalk CURB CUTS
  - i. A CURB CUT requires a permit from the City Engineer and must be compliant with all City Ordinances.
  - ii. Unless otherwise specified, the City Engineer may not permit more than one (1) CURB CUT per FRONT LOT LINE of a LOT.
  - iii. CURB CUTS are prohibited along all THOROUGHFARES designated as a PEDESTRIAN STREET.
  - iv. CURB CUTS must be located to minimize conflicts with pedestrians and bicyclists and must have a clear distance from fire hydrants, STREET TREES, utility poles, and other furnishings as deemed necessary by the City Engineer.
    - a). CURB CUTS for commercial or high-volume driveways should be at least one-hundred (100) feet from an UNSIGNALIZED or SIGNALIZED intersection.
    - b). CURB CUTS for residential driveways should be at least twenty (20) feet from an UNSIGNALIZED intersection and at least forty (40) feet from a SIGNALIZED intersection.
  - v. The interior width of a CURB CUT (between curb stones) may be no wider than the driveway, vehicular entrance, or loading facility it serves.
  - vi. A DRIVEWAY APRON may be installed only within the furnishing zone of a sidewalk and must be constructed in accordance with all standards established by relevant City Departments.
  - vii. The grade, cross slope, and clear width of the walkway of a sidewalk must be maintained between the DRIVEWAY APRON and the ABUTTING driveway. The appearance of the walkway (ie. scoring pattern or paving material) must indicate that, although a vehicle may cross, the area traversed by a vehicle remains part of the sidewalk.

**Figure 7.2.11 Sidewalk Curb Cuts**

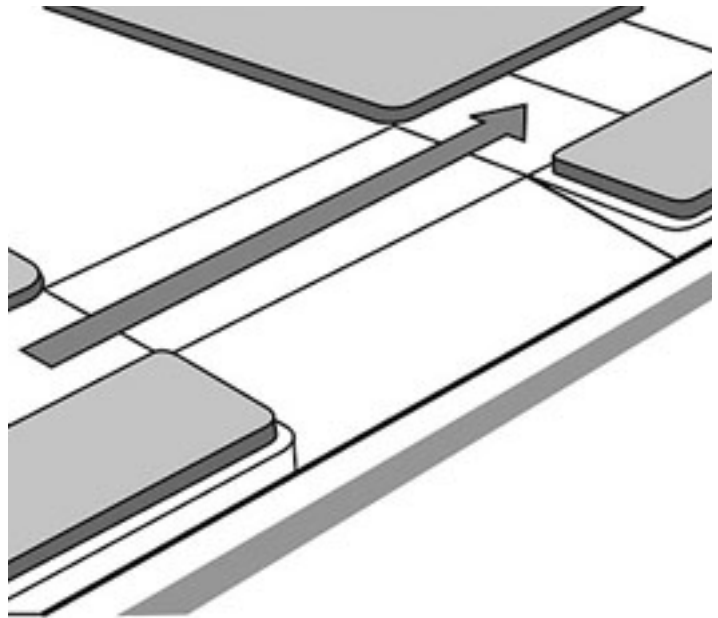

# 7 SPECIAL DISTRICTS

Powderhouse School (PS)



## **7.3 TUFTS UNIVERSITY (TU)**

### **1. Character Description**

The Tufts University district is characterized by a large private research university set in a campus like setting. A wide variety of administration buildings, lecture halls, academic centers, dining facilities, student housing, and recreation facilities are typically SETBACK from the STREET. Well landscaped commons and BUILDING grounds provide outdoor space for students, employees, and visitors.



# 7 SPECIAL DISTRICTS

Tufts University (TU)

## 2. Intent

- a. To maintain an area of the city for the campus of a educational institution.
- b. To preserve land areas primarily dedicated to collegiate Education Services PRINCIPAL USES protected by M.G.L., Chapter 40A, Section 3 and other USES necessary to maintain an academic campus.

## 3. Purpose

- a. To reduce the impact of higher intensity educational USES on surrounding residential properties by reducing the height of buildings at the edge of the campus and locate taller buildings toward the center of the campus.
- b. To distribute the coverage and floor area of buildings across the quadrants of the district in a generally even distribution as to not overly cluster DEVELOPMENT.

## 4. Applicability

- a. The section is applicable to all real property within the Tufts University district as shown on the maps of the Official Zoning Atlas of the City of Somerville.
- b. The provisions of this Section are applicable only to the portion(s) of any BUILDING within the City of Somerville and are not applicable to any portion(s) located within the City of Medford.
- c. Unless otherwise specified, where the provisions of this Section conflict with those found elsewhere in this Ordinance, the provisions of this Section apply.

## 5. Development Review

- a. General
  - i. DEVELOPMENT review is subject to the provisions of Article 15: Administration of this Ordinance.
  - ii. All DEVELOPMENT, excluding NORMAL MAINTENANCE, requires the submittal of a development review application to the BUILDING OFFICIAL and the issuance of a Certificate of Zoning Compliance prior to the issuance of a SITE Disturbance Permit, BUILDING Permit, or Certificate of Occupancy.
  - iii. Proposed DEVELOPMENT may or may not necessitate the need for SUBDIVISION Plan Approval, Site Plan Approval, a Special Permit, or a Hardship Variance based on the nature of the proposal. In such cases, additional DEVELOPMENT review is required in accordance with Article 15: Administration.
- b. Authority
  - i. The Zoning Board of Appeals is the decision making authority for all DEVELOPMENT in the TU district.
- c. Special Permits
  - i. Review Criteria
    - a). In addition to the review criteria for all Special Permits specified in §15.2.1.e. Review Criteria, the review board shall make findings

considering the following in its discretion to approve or deny any Special Permit required by this section:

- i). Impact on surrounding residential properties.
- ii). Impact on the experience of the PUBLIC REALM that would result from strict compliance to the standards of this Ordinance.

## 6. Lots

- a. DEVELOPMENT is exempt from Section 10.1 Land Platting of this Ordinance and all real prtoperty within the TU district, including portions of campus situated in whole or in part within the City of Medford, is considered a single DEVELOPMENT SITE.

## 7. Building Standards

- a. General
  - i. Multiple principle buildings are permitted on each LOT.
- b. Existing STRUCTURES
  - i. The BUILDING OFFICIAL shall deem all buildings and structures to be in compliance with the building standards of this section.
- c. BUILDING Placement
  - i. All buildings and STRUCTURES must be located at or behind the following SETBACKS:
    - a). Twenty (20) feet from the FRONT LOT LINE ABUTTING College Avenue between Talbot Avenue and Powder House Boulevard, Powder House Boulevard from College Avenue to Packard Avenue, and Packard Avenue from Powder House Boulevard to Talbot Avenue.
    - b). Fifteen (15) feet from the FRONT LOT LINE ABUTTING DEARBORN Road and Curtis STREET northwesterly of Sawyer Avenue.
  - ii. Within the portion of the Tufts University district which lies on the southwesterly side of Sawyer Avenue between Packard Avenue and Curtis STREET,
    - a). where BUILDING length is less than thirty (30) feet, the SETBACK is calculated as follows, with a minimum of fifteen (15) feet required for front yards and a minimum of twenty (20) feet required for rear yards:
      - i).  $SETBACK = height + length$  (facing front/REAR LOT LINE) 4
    - b). and where BUILDING length is more than thirty (30) feet, the SETBACK is calculated as follows:
      - i).  $SETBACK = height + length$  (facing front/REAR LOT LINE) 3
    - c). and each BUILDING must be separated from all other buildings by at least seventeen (17) feet.
- d. Buiding Height

**Map 7.3.7(a) Tufts University Height Map**



- i. Maximum BUILDING height is permitted as specified on Table 7.3.7 and shown on Map 7.3.7(a) for the following areas:
  - a). The Blue Band comprises the land within one hundred (100) feet of the following:
    - i). the center line of DeARBORN Road,
    - ii). the center line of College Avenue,
    - iii). the center line of Powder House Boulevard,
    - iv). the center line of that portion of Packard Avenue between Powder House Boulevard and the southwesterly line of Sawyer Avenue, or
    - v). the center line of Curtis STREET between Sawyer Avenue and the City line, or
    - vi). lies southwesterly of the center line of Sawyer Avenue between Packard Avenue and Curtis STREET.
  - b). The Red Band comprises the land within the Tufts University district which is not included in the Blue Band and is within two hundred (200) feet of the following:

**Table 7.3.7 Building Height**

Location	Stories	Feet
With the Blue Band	2.5	35
Within the Red Band	4	56
Within the Yellow Band	6	72
Within the Green Band	8	98

- i). the center line of DeARBORN Road,
- ii). the center line of College Avenue,
- iii). the center line of Powder House Boulevard,
- iv). the center line of that portion of Packard Avenue between Powder House Boulevard and the southwesterly line of Talbot Avenue, or
- v). the center line of Curtis STREET between Sawyer Avenue and the City line, or
- vi). is within one hundred (100) feet of the center line of Sawyer Avenue, between the Red Band measured from Curtis STREET

# 7 SPECIAL DISTRICTS

Tufts University (TU)

**Map 7.3.7 (b) Tufts University Measuring PARCELS**



and the Red Band measured from Packard Avenue.

- c). The Yellow Band comprises the land within the Tufts University district which is not included in the Blue Band or the Red Band and is
  - i). within the BLOCK bounded by Sawyer Avenue, Curtis STREET, Professors Row and Packard Avenue, or
  - ii). within the area bounded by Professors Row, Curtis STREET, the City Line and a line parallel to and three hundred fifty (350) feet southeasterly from Curtis STREET.
- d). The Green Band comprises the land within the Tufts University district which is not included in the Blue Band, the Red Band, or the Yellow Band.
- e. BUILDING MASSING
  - i. DEVELOPMENT SITES must be equal to one (1) of the measuring PARCELS shown on Map 7.3.7(a) established for the following areas:
    - a). MP-1: The land bounded by Professors Row, College Avenue, Powder House Boulevard and Packard Avenue.
    - b). MP-2: The land bounded by Curtis STREET, Professors Row, Packard Avenue, and the Tufts University district line running from Packard Avenue to Curtis STREET between Sawyer Avenue and Whitfield Road.
    - c). MP-3: The land bounded by Boston Avenue, College Avenue, Professors Row, Curtis STREET, Winthrop STREET, the northeasterly side line of Capen STREET Extension, and the westerly sidelines of University Avenue extended to Capen STREET Extension.
    - d). MP-4: The land bounded by Boston Avenue, DEARBORN Road and College Avenue.
  - ii. Development review applications must identify the total land area, total LOT coverage, total NET FLOOR AREA, and total floor area ratio for all structures within the subject measuring PARCEL.
  - iii. The maximum LOT coverage for each measuring PARCEL is sixty-five percent (65%).



- iv. The maximum floor area ratio for each measuring PARCEL is 2.0.
- v. The maximum FLOOR PLATE of any individual building is fifteen thousand (15,000) gross square feet.

**8. Use Provisions**

- a. General
  - i. The USE of real property is subject to the provisions of Article 9.0 USE Provisions of this Ordinance. Where the provisions of this section conflict with those of Article 9.0, the provisions of Article 9 apply.
- b. Permitted Uses
  - i. The USE of real property is permitted as an educational service, including all facilities customarily provided by educational service USES in directly serving the needs of faculty, staff, students, and visitors, as deemed necessary by Tufts University, in accordance with the provisions of Article 9: USE Provisions.

**9. Parking & Mobility**

- a. General
  - i. DEVELOPMENT is subject to the provisions of Article 11: Parking & Mobility of this Ordinance. Where the provisions of this section conflict with those of Article 11, the provisions of Article 11 apply.
  - ii. Vehicular parking must be provided as specified on Table 7.3.9 (a) based on the total number of persons in the Tufts University campus population, including faculty, staff, students, and visitors. The total number of motor vehicle parking spaces provided on the Tufts University campus must be equal to the sum of the products for each row of Table 7.3.9 (a).
- b. Type
  - i. MOTOR VEHICLE PARKING may be provided as SURFACE PARKING spaces, above ground STRUCTURED PARKING, underground STRUCTURED PARKING, and on STREET parking spaces which are owned or controlled by Tufts University.
- c. Parking Design
  - i. The design of all motor vehicle parking is subject

- to §11.1 Bicycle Parking and §11.2 MOTOR VEHICLE PARKING of this Ordinance.
- ii. PARKING LOTS located within the red, yellow, or green bands as shown on Map 7.3.7(a) are exempt from §11.2.2.b.iv.
- d. Parking Location
  - i. MOTOR VEHICLE PARKING may be located anywhere on or within five hundred (500) feet of the Tufts University campus and need not be located within the City of Somerville.
  - ii. To ensure that motor vehicle parking spaces are reasonably distributed throughout the Tufts University campus, a minimum and maximum percentage of the required motor vehicle parking spaces must be located as specified on Table 7.3.9(b).
- e. Parking ACCESS
  - i. Tufts University shall establish and administer a parking permit program for motor vehicle parking spaces provided on the Tufts Univeristy campus.
  - ii. Parking permits may be issued only to Tufts University faculty, staff, or students and to visitors having a need for parking for temporary USE.
  - iii. Parking permits may be issued for general USE of motor vehicle parking spaces or for limited USE of specific parking spaces or for limited time periods.
- f. Annual Reporting
  - i. Tufts University shall submit an annual report to the Director of Mobility within sixty (60) days after September 1st in each year that identifies the following:
    - a). The number and location of motor vehicle parking spaces provided by Tufts University to faculty, staff, students, and visitors.
    - b). The average number of persons in the Tufts University campus population, including faculty, staff, students, and visitors, organized by the categories of Table 7.3.9 (a).
    - c). The average of the number of persons holding Tufts University parking permits broken down by type, if applicable, during the preceding

**Table 7.3.9 (a) Required Parking Spaces**

	<b>Multiplier</b>
Full Time Faculty & Staff	0.47
Part Time Faculty & Staff	0.37
Campus Resident Students	0.12
Non Campus Resident Students	0.24
Other	0.44

**Table 7.3.9 (b) Parking Space Location**

<b>Location</b>	<b>Min</b>	<b>Max</b>
Area between Professors Row - DEARBORN Road in Somerville and Boston Avenue in Medford	25%	75%
Area southwesterly of Professors Row in Somerville	10%	50%
Area easterly of Boston Avenue in Medford: minimum	10%	60%

## 7 SPECIAL DISTRICTS

Tufts University (TU)

twelve month period.

- d). Any known incidences of motor vehicle parking spaces used by persons not holding Tufts University parking permits.
- g. Parking Demand Study
  - i. Tufts University shall submit a parking demand study, prepared by a qualified professional consultant, every three (3) years. If the parking demand study identifies a deficiency in the number of motor vehicle parkingw spaces provided by Tufts University compared to the number of motor vehicle parking spaces required by Table 7.3.9 (a), Tufts University shall also submit a plan for the interim and long term correction and elimination of such a deficiency.
- h. Parking Relief
  - i. If the parking demand study indicates that a lesser number of motor vehcile parking spaces is necessary than is required by Table 7.3.9 (a), the Director of Mobility may permit a reduction in the number of motor vehicle parking spaces provided by up to twenty-five (25) percent. Permission granted for such reduction remains in effect for an initial period of not more than three (3) years, but may subsequently be extended or granted for a longer period upon reasonable verification in the annual report that the parking provided remains adequate.
- i. Loading Facilities
  - i. Buildings located within the red, yellow, or green bands as shown on Map 7.3.7(a) are exempt from §11.2.5.b.i.



## **7.4 ASSEMBLY SQUARE MIXED-USE (ASMD)**

### **1. Description**

The Assembly Square district is characterized by a variety of mid- and HIGH-RISE, transit oriented, mixed-USE buildings; an urban scale THOROUGHFARE network and BLOCK size conducive to a walkable neighborhood; and a variety of CIVIC SPACE types that serve the various social and recreational needs of neighborhood residents, workers, and visitors. Buildings are typically developed at the full-BLOCK or half-BLOCK scale to mask PARKING STRUCTURES from public view. The district features GROUND STORY retail, high-density residential, and large commercial uses that draw customers and employees from the broader Boston metropolitan area.

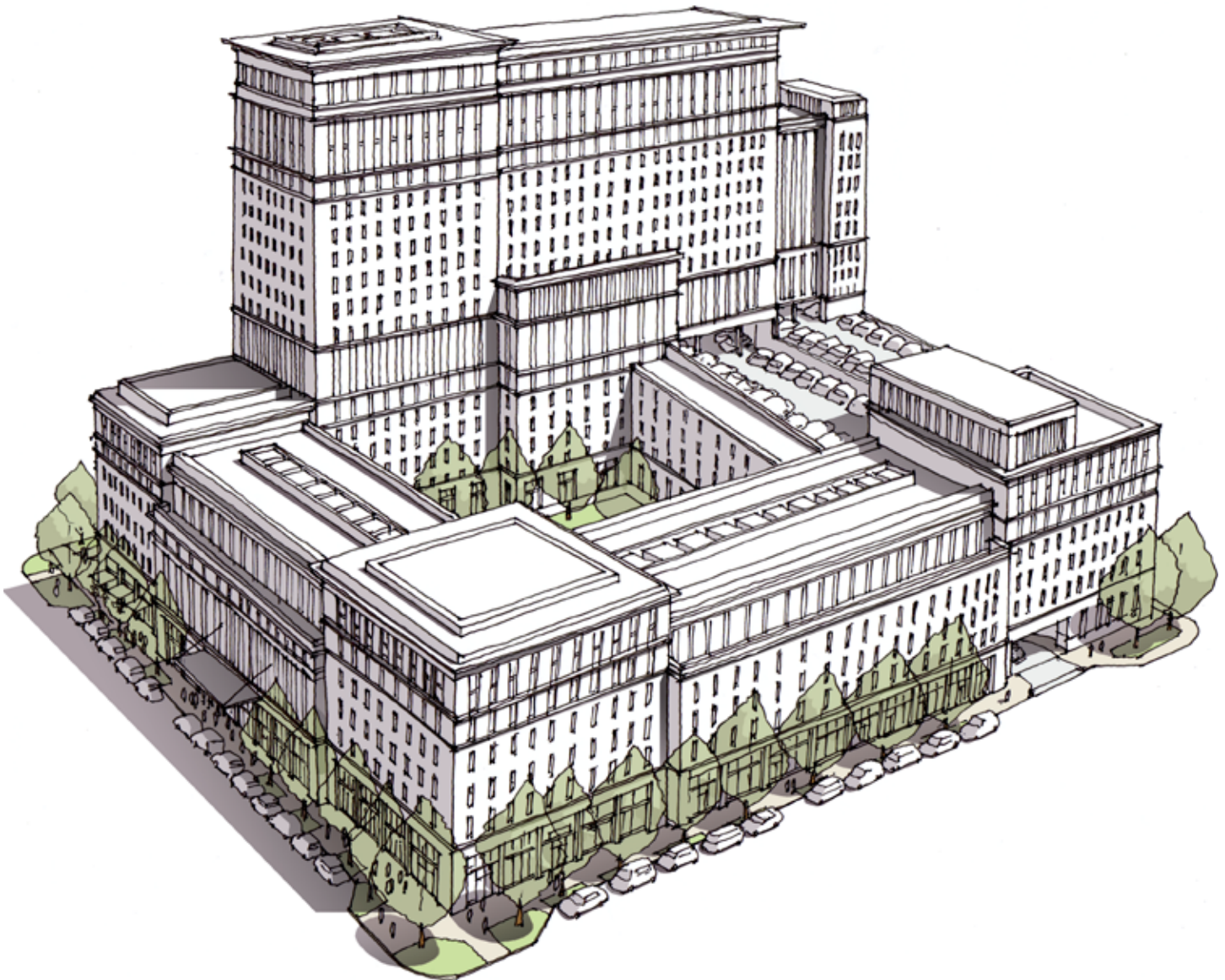

# 7 SPECIAL DISTRICTS

## Assembly Square Mixed-Use (ASMD)

### 1. Intent

- a. To implement recommendations of SomerVision for transformational REDEVELOPMENT.
- b. To implement the ASSEMBLY SQUARE PLAN (ASQ Plan).
- c. To redevelop underutilized areas within close walking distance to the Assembly Square T-station with mixed-USE, mid-rise and HIGH-RISE, transit-oriented DEVELOPMENT that will support the transformation of Assembly Square into an urban commerce center.
- d. To improve the Mystic River waterfront and create new CIVIC SPACE within the Assembly Square district.
- e. To improve utility INFRASTRUCTURE, THOROUGHFARES, off-STREET pedestrian and bicycle paths, and physical connections to surrounding areas, including East Somerville, Ten Hills, and Sullivan Square.

### 2. Purpose

- a. To permit the DEVELOPMENT of multi-unit, mixed-USE, and commercial mid-rise and HIGH-RISE buildings.
- b. To provide quality commercial spaces and permit small and medium-scale, neighborhood-, community-, and region-serving commercial USES.
- c. To permit larger buildings and increased residential density following the approval of a Master Plan Special Permit.
- d. To USE discretion in the permitting of loading and service areas.
- e. To provide flexibility in the permitting of SIGNS.

### 3. Applicability

- a. The section is applicable to all real property within the Assembly Square Mixed-USE district as shown on the maps of the Official Zoning Atlas of the City of Somerville.
- b. Unless otherwise specified, where the provisions of this Section conflict with those found elsewhere in this Ordinance, the provisions of this Section apply.
- c. Real property subject to a previously approved Planned Unit DEVELOPMENT (PUD) Preliminary Master Plan may be developed in accordance with the provisions of the ASMD district effective as of August 1, 2019.

### 4. Development Review

- a. General
  - i. DEVELOPMENT review is subject to the provisions of Article 15: Administration of this Ordinance.
  - ii. All DEVELOPMENT, excluding NORMAL MAINTENANCE, requires the submittal of a development review application to the BUILDING OFFICIAL and the issuance of a Certificate of Zoning Compliance prior to the issuance of a BUILDING Permit or Certificate of Occupancy.
  - iii. Proposed DEVELOPMENT may or may not necessitate the need for Master Plan Special Permit,

Subdivision Plan Approval, Site Plan Approval, a Special Permit, or a Hardship Variance based on the nature of the proposal. In such cases, additional DEVELOPMENT review is required in accordance with Article 15: Administration.

- a). The Planning Board is the decision making authority for all DEVELOPMENT that requires Master Plan Special Permit, Site Plan Approval or a Special Permit.
- b). The Zoning Board of Appeals is the Review Board for all HardSHIP Variances.
- iv. Upon verification that no additional DEVELOPMENT review is necessary, or completion of the required DEVELOPMENT review, the BUILDING OFFICIAL shall issue a Zoning Compliance Certificate to certify compliance with the provisions and procedures of this Ordinance.
- b. Master Planned DEVELOPMENT
  - i. Proposed DEVELOPMENT involving the SUBDIVISION of a DEVELOPMENT SITE, DEVELOPMENT of two (2) or more LOTS, or the DEVELOPMENT of any building over fifty thousand (50,000) GROSS FLOOR AREA requires a Master Plan Special Permit as a prerequisite to the DEVELOPMENT review for the SUBDIVISION or individual LOT.
  - ii. In addition to the review criteria for all for all Master Plan Special Permits specified in §15.2.2.e. Review Criteria, the review board shall make findings considering the following:
    - a). Consistency with the ASQ Plan.
  - iii. DEVELOPMENT SITES are not permitted to include portions of land area separated by more than one hundred (100) feet in distance.
- c. Site Plan Approval
  - i. In addition to the review criteria for all Site Plan Approvals specified in §15.3.2.e. Review Criteria, the review board shall make findings considering the following:
    - a). Consistency with the ASQ Plan.
    - b). Conformance with an approved Master Plan Special Permit and any other Special Permits applicable to the subject LOT.
- d. Plan Revisions
  - i. The Director of Planning & Zoning shall consider the following revisions to an approved development review application to be a MAJOR AMENDMENT in accordance with §15.2.4 Plan Revision:
    - a). any increase in floor area or LOT coverage by fifteen percent (15%) or more;
    - b). substantial changes in ACCESS to a DEVELOPMENT SITE; and
    - c). MODIFICATIONS that result in a condition that is substantially more detrimental to the surrounding neighborhood than the existing

condition(s) or previously approved plans.

**5. Master Plan Standards**

- a. THOROUGHFARE Network
  - i. The alignment and connectivity of THOROUGHFARES must be consistent with the ASQ Plan.
- b. CIVIC SPACE
  - i. At least twenty percent (25%) of a DEVELOPMENT SITE, excluding THOROUGHFARES, must be provided as one or more CIVIC SPACES.
  - ii. CIVIC SPACES are subject to the provisions of Article 13: PUBLIC REALM of this Ordinance.
  - iii. CIVIC SPACES must be dedicated to the public in perpetuity by a covenant or other deed restriction.
  - iv. CIVIC SPACE created through EASEMENT or decommissioning of an existing THOROUGHFARE or other ABUTTING right-of-way may be counted toward the required amount of CIVIC SPACE.
  - v. Any DEVELOPMENT SITE ABUTTING the MYSTIC RIVER BANK must provide at least two hundred and thirty five thousand (235,000) square feet of CIVIC SPACE ABUTTING the Mystic River.
  - vi. CIVIC SPACES ABUTTING the Mystic River must be designed to reduce the level of storm water runoff into the river and with special attention to the provision of wildlife habitat.
- c. Mixed Uses
  - i. Proposed DEVELOPMENT with any single commercial space over fifty thousand (50,000) square feet of LEASABLE FLOOR AREA dedicated to any PRINCIPAL USE from the Retail Sales USE category must dedicate at least sixty percent (60%) of any additional LEASIBLE FLOOR AREA to PRINCIPAL USES that are not from the Retail Sales USE category.

**6. Building Standards**

- a. General
  - i. One (1) PRINCIPAL BUILDING is permitted on each LOT as specified on Table 7.4.7.
    - a). PRINCIPAL BUILDINGS with up to ten thousand (10,000) square feet of GROSS FLOOR AREA are permitted BY RIGHT.
    - b). PRINCIPAL BUILDINGS over ten thousand (10,000) square feet and up to fifty thousand (50,000) square feet of GROSS FLOOR AREA are permitted by Site Plan Approval.
    - c). Buildings over fifty thousand (50,000) square feet of GROSS FLOOR AREA are permitted by Site Plan Approval subject to an approved Master Plan Special Permit.
  - ii. PRINCIPAL BUILDINGS are prohibited within one-hundred and fifty (150) feet of the MYSTIC RIVER BANK.
  - iii. STRUCTURED PARKING, whether above grade or below

grade, is excluded for purposes of calculating GROSS FLOOR AREA, NET FLOOR AREA and Floor Area Ratio in the ASMD.

- iv. ACCESSORY STRUCTURES in any CIVIC SPACE located within one-hundred and fifty (150) feet of the MYSTIC RIVER BANK may be up to thirty (30) feet in height.
- v. The Planning Board may waive the provisions of §74.6 BUILDING Standards or the dimensional standards of Table 7.4.6 by Special Permit.
  - a). In addition to the review criteria for all Special Permits specified in §15.2.1.e. Review Criteria, the review board shall make findings considering the following in its discretion to approve or deny a special permit authorizing a WAIVER from the provisions of §74.6 BUILDING Standards or the dimensional standards of Table 7.4.6:
    - i). Consistency with the ASQ Plan.
- b. BUILDING SETBACKS
  - i. Buildings should be set back from the FRONT LOT LINE no more than five (5) feet except in special

**Table 7.4.6 Dimensional Standards**

	<b>Up to 10,000 GFA</b>	<b>10,000 - 50,000 GFA</b>	<b>Over 50,000 GFA</b>
<b>LOT Standards</b>			
LOT AREA (min)	5,000 sf	10,000 sf	n/a
OPEN SPACE (min)	25%	25%	--
<b>BUILDING Standards</b>			
Floor Area Ratio (max)	1.0	2.0	10.0
BUILDING Height (max)	--	--	--
150 ft - 250 ft of the MYSTIC RIVER BANK	40 ft	50 ft	70 ft
250 ft - 350 ft of the MYSTIC RIVER BANK	40 ft	50 ft	90 ft
Within 1,000 ft of an Assembly Square Station Entrance	40 ft	50 ft	250 ft
All other Locations	40 ft	50 ft	125 ft
<b>Density</b>			
LOT AREA/DWELLING UNIT (min)	--	--	--
1-9 Units	600	600	none
10+ Units	300	300	none



# 7 SPECIAL DISTRICTS

## Assembly Square Mixed-Use (ASMD)

circumstances, where greater SETBACKS would enhance the pedestrian friendly experience of the frontage.

### c. BUILDING Design Standards

- i. Building FACADES must provide solid material framing each storefront and lobby entrance as follows:
  - a). PILASTERS or columns supporting a horizontal lintel and CORNICE;
  - b). a spandrel positioned between PILASTERS or columns that extend from upper stories of the building to the ground; or
  - c). flat wall above and to either side of a void or punched opening.
- ii. Storefronts and lobby entrances must be set within the resulting frame provided for each by the building FACADE.
- iii. Materials framing each storefront or lobby entrance may be integrated into the design of the building or customized for individual storefronts and lobby entrances.
- iv. FACADES must be ARTICULATED to create surface relief and shadow lines that add depth to the FACADE through the USE of architectural elements such as balconies, Bays, CLADDING, columns, CORNER BOARDS, CORNICES, door surrounds, moldings, PIERS, PILASTERS, seat walls, sills, wall depth, and windows that either recess or project from the average plane of the FACADE by at least four (4) inches.
- v. PRINCIPAL ENTRANCES must be clearly defined, through the USE of BUILDING elements such as canopies, porticos, overhangs, peaked roof forms, and/or arches. Outdoor PATIOS, tile work, moldings, integral PLANTERS or wing walls with landscaped areas, or places for sitting are required for entries set back from the FRONT LOT LINE.
- vi. GROUND STORY BUILDING FACADES and accompanying PRINCIPAL ENTRANCES must provide extensive areas of window glass to provide visual ACCESS to interior USES.
- vii. BUILDING FACADES must include windows providing visual ACCESS to the interior of a space, arcades, display windows, entry areas, awnings, or other such features along no less than seventy (70) percent of the horizontal length of all GROUND STORY FACADES that face public THOROUGHFARES or the Mystic River.
- viii. Forty percent (40%) of this activated FACADE area on the GROUND STORY of BUILDING walls along primary and secondary STREETS must consist of window or doors meant for public entry and exit.
- ix. Uninterrupted or unfenestrated lengths of FACADE exceeding thirty-five (35) horizontal feet are prohibited.

### d. Building Design Guidelines

- i. FACADES should be vertically ARTICULATED into a series of ARCHITECTURAL BAYS no wider than thirty (30) feet.
  - ii. ARCHITECTURAL BAYS should be derived, in general, from the BUILDING's structural bay spacing.
  - iii. ARCHITECTURAL BAYS should have PIERS (flat wall), PILASTERS, or columns that either extend all the way to the ground or to the CORNICE and SIGN BAND of ground level storefronts frames.
  - iv. ARCHITECTURAL BAYS should align, in general, with individual or groups of storefronts and lobby entrances.
  - v. The location, alignment, and massing of residential TOWERS should limit the obstruction of desirable views from inside DWELLING UNITS and increase the actual or perceived distance between TOWERS.
  - vi. GROUND STORY commercial spaces should be dedicated to USES from the Retail Sales, Food & Beverage, or Commercial Services USE categories to encourage pedestrian activity.
  - vii. Multiple and frequent entrances oriented toward FRONT LOT LINES are encouraged.
  - viii. GROUND STORY commercial spaces should take advantage of views of the waterfront and other OPEN SPACES, and add a STREET front presence to public THOROUGHFARES and sidewalks.
  - ix. DEVELOPMENT surrounding OPEN SPACE should result in a net benefit to the space in terms of activation, enhanced quality and attractiveness, expanded USE, and public ACCESS.
  - x. The selection of materials, FENESTRATION, and ornamentation should result in a consistent and harmonious composition that appears as a unified whole rather than a collection of unrelated parts, no matter the style.
  - xi. The type and color of materials USED for a BUILDING should be kept to a minimum, preferably three (3) or fewer.
- ### e. Self-Storage Buildings
- i. Buildings purpose built for self storage USES must be designed as follows:
    - a). FACADES greater than one hundred (100) feet in horizontal width must have a change in vertical plane of at least eight (8) inches (in depth or projection) for at least one (1) ARCHITECTURAL BAY to divide the BUILDING's form and break up its apparent mass into smaller elements. FACADES oriented toward any interstate highway are exempt.
    - b). GROUND STORY FACADES must include FENESTRATION for a minimum of forty percent (40%) of the wall area. FACADES oriented toward any interstate highway are exempt.
    - c). UPPER STORY FACADES must include FENESTRATION

for between twenty percent (20%) minimum and seventy percent (70%) maximum of the wall area of each STORY. UPPER STORY FENESTRATION must be designed to appear as windows for residential or commercial USES.

- d). FACADES may have a maximum BLANK WALL area of thirty five (35) feet.
- e). UPPER STORY USES must have an at-grade PRINCIPAL ENTRANCE designed as a lobby. Lobby entrances may be no wider than thirty (30) feet in width and must be well-defined, clearly visible, and universally ACCESSIBLE from the ABUTTING sidewalk.
- f). When a lobby entrance is set back from the FRONT LOT LINE, the SETBACK must be paved to match the ABUTTING sidewalk.

**7. Use Provisions**

- a. General
  - i. The USE of real property is subject to the provisions of Article 9: Use Provisions of this Ordinance. Where the provisions of this section conflict with those of Article 9, the provisions of Article 9 apply.
  - ii. USE categories are permitted as specified on Table 7.4.7. USE categories not identified on Table 7.4.7 are prohibited.
  - iii. All USES must comply with any USE-specific standards applicable for each USE in §9.2 Use Definitions & Limitations and this Section.
  - iv. USES permitted by Special Permit require additional DEVELOPMENT review in accordance with §15.2.1 Special Permits.
- b. Definitions & Use Specific Standards
  - i. General
    - a). This section provides definitions and standards applicable to individual USES not already identified in Article 9: Use Provisions of this Ordinance.
  - ii. Industrial
    - a). Marina
      - i). A SITE USED for docking and storage of pleasure boats or services for pleasure boaters, including minor repair of boats while in the water, sale of fuel and supplies, or provision of food, beverages, and entertainment. ANCILLARY long-term dry storage of recreational watercraft in racks or other storage systems may be provided.
- c. USE Limitations
  - i. Occupancy of any single GROUND STORY commercial space over fifty thousand (50,000) square feet in LEASABLE FLOOR AREA by any USE from the Retail Sales USE category is prohibited.
  - ii. Occupancy of any single commercial space greater

**Table 7.2.7 Permitted Uses**

Use Category Specific Use	ASO
<b>Arts &amp; Creative Enterprise</b>	
Artisinal Production	P
Arts Exhibition	P
Arts Sales & Services	P
Co-Working	P
Design Services	P
Shared Workspaces & Arts Education	P
<b>Auto-Oriented</b>	
Dispatch Service (except as follows)	P
Towing Service	N
Gasoline Station	P
Motor Vehicle Parking (as noted below)	--
Off-Site Accessory Parking	P
Vehicle Sales	P
<b>Civic &amp; Institutional</b>	
Community Center	P
Hospital	P
Library	P
Minor Utility Facility	P
Museum	P
Private Non-Profit Club or Lodge	P
Public Service	P
Religious & Educational Uses Protected by M.G.L. 40A. Sec. 3	P

P - Permitted    SP - Special Permit Required    N - Not Permitted

than ten-thousand (10,000) square feet in LEASABLE FLOOR AREA by any permitted USE requires a Special Permit.

- iii. In addition to the review criteria for all Special Permits specified in §15.2.1.e. Review Criteria, the review board shall make findings considering the following in its discretion to approve or deny a special permit authorizing occupancy of any single commercial space over ten-thousand (10,000) square feet in LEASABLE FLOOR AREA by any permitted USE:
  - a). Compatibility with the intensity of activity associated with the surrounding land USES.

# 7 SPECIAL DISTRICTS

Assembly Square Mixed-Use (ASMD)

**Table 7.2.7 Permitted Uses**

Use Category Specific Use	ASO
<b>Commercial Services</b>	
Animal Services (as noted below)	--
Commercial Kennel	P
Veterinarian	P
<b>Assembly or Entertainment</b>	P
<b>Banking &amp; Financial Services (except as follows)</b>	P
Personal Credit	N
<b>Broadcast and/or Recording Studio</b>	P
<b>Business Support Services</b>	P
<b>Caterer/Wholesale Food Production</b>	P
<b>Day Care Service (as noted below)</b>	--
Adult Day Care Center	P
Child Day Care Center	P
<b>Educational Services</b>	P
<b>Maintenance &amp; Repair of Consumer Goods</b>	P
<b>Personal Services (except as follows)</b>	P
Body-Art Services	P
Fitness Services	P
Funeral Services	N
Health Care Services	P
Formula Personal Services	P
<b>Vehicle Parking (except as follows)</b>	--
Bike Share Parking	P
Car Share Parking (3 or less)	P
Car Share Parking (4 or more)	SP
Public Parking	P
<b>Food and Beverage Service</b>	
Bar/Restaurant/Tavern	P
Bakery/Café/Coffee Shop	P

P - Permitted    SP - Special Permit Required    N - Not Permitted

**Table 7.2.7 Permitted Uses**

Use Category Specific Use	ASO
<b>Industrial</b>	
Manufacturing	P
Marina	P
Moving and/or Self Storage (except as follows)	N
Self Storage	P
Recycling Collection	P
Wholesale Trade & Distribution	P
<b>Lodging</b>	
Hotel or Hostel	P
<b>Office</b>	
General Office	P
Research and Development and Laboratory	P
<b>Residential</b>	
Household Living	P
Group Living (except as follows)	SP
Community or Group Residence	P
Dormitory, Fraternity or Sorority	SP
Homeless Shelter	SP
Nursing Home/Assisted Living Facility	SP
Rooming House	SP
<b>Retail Sales</b>	
Building/Home Supplies & Equipment	P
Consumer Goods (except as follows)	P
Alcohol Sales	P
Firearms Sales	N
Pet Store	N
Fresh Food Market or Grocery Store	P
Farm/Vendor Market	P
<b>Urban Agriculture</b>	
Farming (as noted below)	--
Commercial Farming	P

P - Permitted    SP - Special Permit Required    N - Not Permitted



**Table 7.2.7 Permitted Uses**

Use Category Specific Use	ASQ
<b>Accessory Uses</b>	
<b>Home Occupations (as noted below)</b>	--
Creative Studio	N
Hobby Kennel	N
Home-Based Business	N
Home Day Care	P
Home Office	N
<b>Urban Agriculture (as noted below)</b>	--
Apiculture	P
Aviculture	P
Commercial Farming	P
Residential Gardening	P
<b>Vehicle Parking, Accessory (except as follows)</b>	P
Home Business Vehicle Parking	P

P - Permitted SP - Special Permit Required N - Not Permitted

- b). Capacity of the local THOROUGHFARE network providing ACCESS to the SITE and the impact on pedestrian, bicycle, and vehicular traffic and circulation patterns in the neighborhood.
- d. Required USES
  - i. Any DEVELOPMENT providing fifty thousand (50,000) net square feet of retail floor area must provide one and one half (1.5) square feet of non-retail USES for every square foot over fifty thousand (50,000) net square feet of Retail USE.
- e. USE Restrictions
  - i. Drive-up and drive-through USES are prohibited.
  - ii. GROUND STORY retail USES over fifty-thousand (50,000) gross square feet are prohibited.
- f. Changes in Use
  - i. Changes in USE within the same USE category are permitted without additional review, provided the following criteria are met:
    - a). The NET FLOOR AREA of the proposed PRINCIPAL USE may not be greater than one hundred and five percent (105%) of the NET FLOOR AREA of the existing USE;
    - b). In the case of USES within the residential USE category, the proposed number of DWELLING UNITS may not exceed the existing number of DWELLING UNITS; and
    - c). The only exterior changes to the BUILDING allowed will be renovations and SIGNAGE.

- ii. The flexibility to move within the same USE category does not apply to legally pre-existing nonconforming USES.
  - iii. As part of an approved Master Plan Special Permit, the Planning Board may specify permitted USES for any or all phases of DEVELOPMENT and permit the change of USE between these specified USES without further review.
- 8. DEVELOPMENT Standards**
- a. General
    - i. DEVELOPMENT is subject to the provisions of Article 10: DEVELOPMENT Standards of this Ordinance. Where the provisions of this section conflict with those of Article 10, the provisions of Article 10 apply.
  - b. SIGNS
    - i. Off-premises SIGNS are prohibited.
    - ii. All SIGNS must comply with standards set forth in Section 10.8. SIGNS except as follows:
      - a). The top of a wall SIGN attached parallel to a BUILDING may be no higher than 35 feet above finished grade.
    - iii. Nonconforming freestanding, directional, or wall SIGNS may be approved by Special Permit.
      - a). In addition to the review criteria for all Special Permits specified in §15.2.1.e. Review Criteria, the review board shall make findings considering the following in its discretion to approve or deny a special permit authorizing a nonconforming freestanding, directional, or wall SIGNS:
        - i). The creation of legible urban environment free from the over USE of SIGNS.
        - ii). Aesthetics, proportion, scale of the proposed SIGN in relation to the BUILDING or storefront.
        - iii). Design, location, and context of other SIGNAGE on the BUILDING and on surrounding properties.
    - iv. The Planning Board may waive the provisions of §7.4.8.b SIGNS by Special Permit.
      - a). In addition to the review criteria for all Special Permits specified in §15.2.1.e. Review Criteria, the review board shall make findings considering the following in its discretion to approve or deny a special permit authorizing a WAIVER from the the provisions of §7.4.8.b SIGNS:
        - i). Consistency with the ASQ Plan.
  - c. Storm Water Management
    - i. Storm water should be removed from all roofs, canopies, and paved areas, and routed through well-engineered systems designed with appropriate storm water management techniques.

# 7 SPECIAL DISTRICTS

## Assembly Square Mixed-Use (ASMD)

- ii. Skimming devices, oil and grease traps, and similar facilities at the collection or discharge points for paved surface must be maintained regularly.
- iii. Where practical, the routing of runoff through sheet flow, swales, or other means that increases filtration and percolation is strongly encouraged.
- iv. The Planning Board may require independent peer review of a storm water management plan by an accredited independent engineering firm.

### 9. Parking & Mobility

- a. General
  - i. DEVELOPMENT is subject to the provisions of Article 11: Parking & Mobility of this Ordinance. Where the provisions of this section conflict with those of Article 11, the provisions of Article 11 apply.
- b. Type
  - i. MOTOR VEHICLE PARKING may be provided as above ground STRUCTURED PARKING or underground STRUCTURED PARKING.
  - ii. SURFACE PARKING LOTS may be permitted on an interim basis by Special Permit.
    - a). In addition to the review criteria for all Special Permits specified in §15.2.1.e. Review Criteria, the review board shall make findings considering the following in its discretion to approve or deny a special permit authorizing a SURFACE PARKING LOT:
      - i). Documented un-met demand for parking;
      - ii). DEVELOPMENT schedule for planned REDEVELOPMENT of the LOT; and
      - iii). capacity of the local THOROUGHFARE network providing ACCESS to the SITE and impact on pedestrian, bicycle, and motor vehicle traffic and circulation patterns in the neighborhood.
- c. Parking Design
  - i. The design of all parking is subject to §11.1 Bicycle Parking and §11.2 MOTOR VEHICLE PARKING of this Ordinance.
- d. Parking Location
  - i. No SURFACE PARKING is permitted within two-hundred (200) feet of the MYSTIC RIVER BANK as defined by 310 CMR 10.54.2.c.
- e. Unbundled Parking
  - i. MOTOR VEHICLE PARKING spaces must be rented or leased as an option rather than a requirement of the rental, lease, or purchase of a DWELLING UNIT or non-residential floor space.
  - ii. Bicycle parking must be provided at no cost or fee to customers, visitors, employees, tenants, and residents.
- f. Loading Facilities
  - i. Loading facilities must be located away from

major public THOROUGHFARES, the Mystic River, and other highly visible locations. The visual impact of exposed loading facilities should be reduced through creative design solutions.

- ii. MODIFICATIONS to, relocations of, or creation of new loading facilities for an existing BUILDING requires a Special Permit.
  - a). In addition to the review criteria for all Special Permits specified in §15.2.1.e. Review Criteria, the review board shall make findings considering the following in its discretion to approve or deny a special permit authorizing a MODIFICATION to, relocation of, or creation of new loading space for an existing BUILDING:
    - i). Documented need for loading facilities.
    - ii). Impact on pedestrian, bicycle, and vehicular traffic and circulation patterns in the neighborhood.

### 10. DEVELOPMENT Benefits

- a. DEVELOPMENT is subject to the provisions of Article 12: DEVELOPMENT Benefits of this Ordinance. Where the provisions of this section conflict with those of Article 12, the provisions of Article 12 apply.
- b. DEVELOPMENT must provide AFFORDABLE DWELLING UNITS as specified on Table 7.2.11 (a).
- c. DEVELOPMENT of a general building must provide linkage payments as specified on Table 7.2.11. (b).

**Table 7.2.10 (a) Required ADUs**

Total DWELLING UNITS	Required ADUs
0 to 5 units	None
6 units	1 unit OR fractional buyout for 0.4 units
7 units	1 unit OR fractional buyout for 0.6 units
8 to 17 units	17.5% of units
18 or more units	20% of units

**Table 7.2.10 (b) Linkage**

Floor Area	Affordable Housing Linkage	Employment Linkage
30,000 sf or less	None	None
Over 30,000 sf	\$10/sf	\$2.46/sf

**11. Public Realm**

- a. General
  - i. DEVELOPMENT is subject to the provisions of Article 13: PUBLIC REALM of this Ordinance. Unless otherwise specified, where the provisions of this section conflict with those of Article 13, the provisions of Article 13 apply.
- b. THOROUGHFARES
  - i. THOROUGHFARE design should be consistent with the ASQ Plan, specifically the 2002 Assembly Square: Design Guidelines for the PUBLIC REALM.
  - ii. DEVELOPMENT SITES ABUTTING Mystic Avenue or Fellway must contribute toward the improvement pedestrian ACCESS to the Ten Hills and East Somerville neighborhoods by means of sidewalk connections, crosswalks, STREETScape landscaping, traffic SIGNALIZATION, and traffic calming, as deemed necessary by the Planning Board.
  - iii. Continuous pedestrian connections must be provided between all major points of pedestrian activity on a DEVELOPMENT SITE, including, but not limited to, connections to the Mystic River waterfront, connections to all public and private ways ABUTTING a DEVELOPMENT SITE, and any TRANSIT STATIONS.
- c. Sidewalk CURB CUTS
  - i. A CURB CUT requires a permit from the City Engineer and must be compliant with all City Ordinances.
  - ii. Unless otherwise specified, the City Engineer may not permit more than one (1) CURB CUT per FRONT LOT LINE of a LOT.
  - iii. CURB CUTS are prohibited along all THOROUGHFARES designated as a PEDESTRIAN STREET.
  - iv. CURB CUTS must be located to minimize conflicts with pedestrians and bicyclists and must have a clear distance from fire hydrants, STREET TREES, utility poles, and other furnishings as deemed necessary by the City Engineer.
    - a). CURB CUTS for commercial or high-volume driveways should be at least one-hundred (100) feet from an UNSIGNALIZED or SIGNALIZED intersection.
    - b). CURB CUTS for residential driveways should be at least twenty (20) feet from an UNSIGNALIZED intersection and at least forty (40) feet from a SIGNALIZED intersection.
  - v. The interior width of a CURB CUT (between curb stones) may be no wider than the driveway, vehicular entrance, or loading facility it serves.
  - vi. A DRIVEWAY APRON may be installed only within the furnishing zone of a sidewalk and must be constructed in accordance with all standards established by relevant City Departments.
  - vii. The grade, cross slope, and clear width of the

**Figure 7.2.11 Sidewalk Curb Cuts**

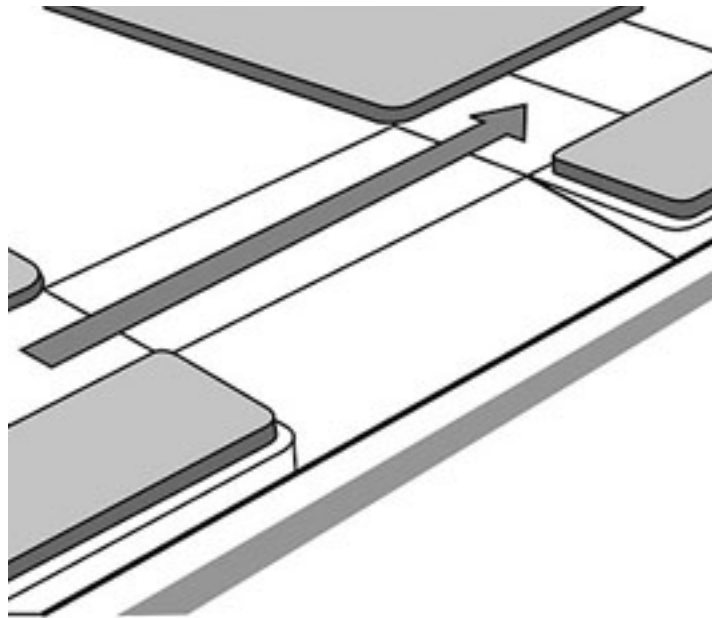

walkway of a sidewalk must be maintained between the DRIVEWAY APRON and the ABUTTING driveway. The appearance of the walkway (ie. scoring pattern or paving material) must indicate that, although a vehicle may cross, the area traversed by a vehicle remains part of the sidewalk.

**12. Land Platting**

- a. The following standards supersede the provisions of Article 13: PUBLIC REALM Standards:
  - i. BLOCK Size
    - a). BLOCKS must have individual BLOCK FACES no greater than five-hundred (500) feet and a total perimeter no greater than eighteen-hundred (1,800) feet.
  - ii. LOTS Width
    - a). LOTS may be platted to have up to a maximum LOT WIDTH of five hundred (500) feet.

# 7 SPECIAL DISTRICTS

Assembly Square Mixed-Use (ASMD)

## 8 OVERLAY DISTRICTS

<b>8.1</b>	<b>SMALL BUSINESS (SB).....</b>	<b>383</b>
	Intent	383
	Purpose	383
	Applicability	383
	Use Provisions	383
	Parking & Mobility	383
<b>8.2</b>	<b>FLOODPLAINS (FP) .....</b>	<b>386</b>
	Intent	386
	Purpose	386
	Applicability	386
	District Boundaries	386
	Definitions	386
	Compliance with Other Regulations	386
	Development Limitations	386
	Notification of Watercourse Alteration	387
<b>8.3</b>	<b>MASTER PLANNED DEVELOPMENT (MPD) .....</b>	<b>388</b>
	Intent	388
	Purpose	388
	Applicability	388
	Urban Design	388
	Development Review	388
	In-Lieu Payments	389
	Thoroughfares & Civic Spaces	390
	Development Standards	390
	Parking & Mobility	390
	Assembly Square (ASQ) Sub-Area	391
	Boynton Yards (BY) Sub-Area	392
	Brickbottom (BB) Sub-Area	395
	Grand Junction (GJ) Sub-Area	396
	Inner Belt (IB) Sub-Area	397
	North Point (NP) Sub-Area	398
	Union Square (USQ) Sub-Area	405
	Union Square East (USQE) Sub-Area	409





## 8.1 SMALL BUSINESS (SB)

### 1. Intent

- a. To implement recommendations of SomerVision for commercial DEVELOPMENT.
- b. To create, maintain, and enhance locations appropriate for neighborhood- and community-serving businesses.

### 2. Purpose

- a. To permit neighborhood- and community-serving commercial USES providing for the frequently recurring needs of local residents.
- b. To USE discretion in permitting the occupancy of commercial spaces over five thousand (5,000) square feet in LEASABLE FLOOR AREA.

### 3. Applicability

- a. The section is applicable to all real property within the Small Business overlay district as shown on the maps of the Official Zoning Atlas of the City of Somerville.
- b. The provisions of this Section supplement or supersede the provisions of the districts upon which it is superimposed.
- c. Where the provisions of this Section conflict with those found elsewhere in this Ordinance, the provisions of this Section apply.

### 4. Use Provisions

- a. General
  - i. USE categories are permitted as specified on Table 8.1 (a).
- b. LEASABLE FLOOR AREA
  - i. Occupancy of any commercial space over five thousand (5,000) square feet in LEASABLE FLOOR AREA by any permitted USE requires a Special Permit.
  - ii. In addition to the review criteria for all Special Permits specified in §15.2.1.e. Review Criteria, the review board shall make findings considering the following in its discretion to approve or deny a special permit authorizing occupancy of a commercial space over five thousand (5,000) square feet in LEASABLE FLOOR AREA by any permitted USE specified on Table 8.5 (a):
    - a). Compatibility with the intensity of activity associated with the surrounding land USES.
    - b). Capacity of the local THOROUGHFARE network providing ACCESS to the SITE and the impact on pedestrian, bicycle, and vehicular traffic and circulation patterns in the neighborhood.

### 5. Parking & Mobility

- a. Vehicular parking must be provided as specified on Table 8.1.5.

# 8. OVERLAY DISTRICTS

Small Business (SB)

**Table 8.1.4 Permitted Uses**

Use Category Specific Use	SB	USE Specific Standards
<b>Arts &amp; Creative Enterprises</b>		
Artisinal Production	P	§9.2.2.a
Arts Exhibition	P	§9.2.2.b
Arts Sales & Services	P	§9.2.2.c
Design Services	P	
Shared Workspaces & Arts Education	P	§9.2.2.f
<b>Civic &amp; Institutional</b>		
Private Non-Profit Club or Lodge	SP	
<b>Commercial Services</b>		
Animal Services (as noted below)	--	
Pet Grooming	P	
Veterinarian	SP	
Building & Home Repair Services	SP	§9.2.5.e
Business Support Services	P	
Day Care Service (as noted below)	--	§9.2.5.h
Adult Day Care Center	P	§9.2.5.h.i
Child Day Care Center	P	§9.2.5.h.ii
Maintenance & Repair of Consumer Goods	P	§9.2.5.j
Personal Services (except as noted below)	P	§9.2.5.k
Body-Art Services	SP	§9.2.5.k.i
Fitness Services	P	§9.2.5.k.ii
Funeral Services	SP	§9.2.5.k.iii
Health Care Services	SP	§9.2.5.k.iv
Formula Personal Services	SP	§9.2.5.l

P - Permitted    SP - Special Permit Required    N - Not Permitted

**Table 8.1.4 Permitted Uses (continued)**

Use Category Specific Use	SB	USE Specific Standards
<b>Food &amp; Beverage Services</b>		
Bar, Restaurant or Tavern	SP	§9.2.6.a
Bakery, Café, or Coffee Shop	SP	§9.2.6.b
Formula Food & Beverage Services	SP	§9.2.6.c
<b>Retail Sales</b>		
Building or Home Supplies & Equipment	SP	§9.2.11.a
Consumer Goods (except as follows)	P	§9.2.11.b
Alcohol Sales	SP	§9.2.11.b.i
Firearms Sales	N	§9.2.11.b.ii
Pet Store	SP	§9.2.11.b.v
Formula Retail Sales	SP	§9.2.11.c
Fresh Food Market or Grocery Store	P	§9.2.10.d
Farm or Vendor Market	P	§9.2.10.e

P - Permitted    SP - Special Permit Required    N - Not Permitted

## 8. OVERLAY DISTRICTS

Small Business (SB)

**Table 8.1.5 Vehicular Parking**

\*See TRANSIT AREAS Map for LOTS located in a TRANSIT AREA

Use Category Specific Use	BICYCLE		MOTOR VEHICLE	
	Short-Term (min)	Long-Term (min)	Inside a TRANSIT AREA (max)	Outside of a TRANSIT AREA (min)
<b>Arts &amp; Creative Enterprise</b>				
All Permitted USES	0.1 / 1,000 sf	0.33 / 1,000 sf	0.8 / 1,000 sf	1.0 / 1,000 sf
<b>Civic &amp; Institutional</b>				
All Permitted USES	0.5 / 1,000 sf	0.1 / 1,000 sf	4 / 1,000 sf	1.0 / 1,000 sf
<b>Commercial Services</b>				
All Permitted USES (except as noted below)	0.4 / 1,000 sf	0.1 / 1,000 sf	1.0 / 1,000 sf	1.0 / 1,000 sf
Business Support Services	–	–	–	0.75 / 1,000 sf
Day Care Service	2 (min)	–	–	0.75 / 1,000 sf
Maintenance & Repair of Consumer Goods	–	–	0.5 / 1,000 sf	–
Personal Services	–	–	0.5 / 1,000 sf	–
<b>Food and Beverage Service</b>				
All Permitted USES	1.0 / 1,000 sf	0.2 / 1,000 sf	0.33 / 1,000 sf	0.5 / 1,000 sf
<b>Retail Sales</b>				
All Permitted USES (except as noted below)	0.4 / 1,000 sf	0.1 / 1,000 sf	1.0 / 1,000 sf	0.66 / 1,000 sf
Farm/Vendor Market	none	none	none	–

sf - Gross Leasable Square Footage

DU - DWELLING UNIT

RU - ROOMING UNIT

# 8. OVERLAY DISTRICTS

## Floodplains (FP)

### 8.2 FLOODPLAINS (FP)

#### 6. Intent

- a. to ensure public safety through reducing the threats to life and personal injury
- b. to eliminate new hazards to emergency response officials
- c. to prevent the occurrence of public emergencies resulting from water quality contamination and pollution due to flooding
- d. to avoid the loss of utility services which if damaged by flooding would disrupt or shut down the utility network and impact regions of the community beyond the SITE of flooding
- e. to eliminate costs associated with the response and cleanup of flooding conditions
- f. to reduce damage to public and private property resulting from flooding.

#### 7. Purpose

- a. To require DEVELOPMENT to be in compliance with applicable provisions of the Massachusetts State BUILDING Code and Massachusetts General Laws.
- b. To appropriately limit DEVELOPMENT within floodways to reduce obstructions to flood flows and reduce flooding impacts on the community.

#### 8. Applicability

- a. Where the provisions of this Section conflict with those found elsewhere in this Ordinance, the provisions of this Section apply.

#### 9. District Boundaries

- a. The FP overlay district includes all special flood hazard areas within the City of Somerville designated as Zone A or Zone AE on the Flood Insurance Rate Map (FIRM) issued by the Federal Emergency Management Agency (FEMA) for the administration of the National Flood Insurance Program.
- b. The map panels of the Middlesex County FIRM, dated June 4, 2010, that are wholly or partially within the City of Somerville are:
  - i. 25017C0417E
  - ii. 25017C0419E
  - iii. 25017C0436E
  - iv. 25017C0438E
  - v. 25017C0439E
  - vi. 25017C0576E
  - vii. 25017C0577E
- c. The boundaries of the FP overlay district are defined by the 100-year base flood elevations shown on the FIRM and further defined by the Middlesex County Flood Insurance Study (FIS) report dated June 4, 2010.
- d. The FIRM and FIS report are incorporated herein by

reference and are on file with the City Clerk, Planning Board, BUILDING OFFICIAL, Conservation Commission and City Engineer.

#### 10. Definitions

- a. For the purpose of this overlay district alone, the definitions of 44 CFR 59.1 apply.

#### 11. Compliance with Other Regulations

- a. All DEVELOPMENT within the FP overlay district must be in compliance with, or operating under duly approved HARDSHIP Variances from, the following regulations:
  - i. Section of the Massachusetts State BUILDING Code which addresses floodplain and coastal high hazard areas (currently 780 CMR 120.G, "Flood Resistant Construction and Construction in Coastal Dunes")
  - ii. Wetlands Protection Regulations, Department of Environmental Protection (DEP) (currently 310 CMR 10.00)
  - iii. Sections of Massachusetts Law which address altering of land bordering waters (currently Chapter 131, Section 40 of the Massachusetts General Laws)
  - iv. Inland Wetlands Restriction (currently 310 CMR 13.00);
  - v. Minimum Requirements for the Subsurface Disposal of Sanitary Sewage (currently 310 CMR 15, Title 5)

#### 12. Development Limitations

- a. In "A" Zones, the BUILDING OFFICIAL shall USE the best available Federal, State, local or other floodway data to prohibit ENCROACHMENTS in floodways which would result in any increase in flood levels within the overlay district during the occurrence of the base flood discharge.
- b. In Zones AE:
  - i. along watercourses that have regulatory floodways designated within the City of Somerville on the FIRM, ENCROACHMENTS are prohibited in the regulatory floodway which would result in any increase in flood levels within the community during the occurrence of the base flood discharge.
  - ii. along watercourses that have not had a regulatory floodway designated, no new construction, substantial improvement, or other DEVELOPMENT is permitted unless it is demonstrated that the cumulative effect of the proposed DEVELOPMENT, when combined with all other existing and anticipated DEVELOPMENT, will not increase the water surface elevation of the base flood discharge.
- c. The following USES of low flood damage potential and causing no obstructions to flood flows are encouraged,

provided they are permitted in the underlying district and they do not require STRUCTURES, fill, or storage of materials or equipment:

- i. outdoor recreational USES
- ii. conservation of water, plants, wildlife
- iii. buildings lawfully existing prior to the adoption of these provisions

**13. Notification of Watercourse Alteration**

- a. The BUILDING OFFICIAL shall notify the following of any alteration or relocation of a watercourse:
  - i. Adjacent Municipalities
  - ii. The State Coordinator for the National Flood Insurance Program at the Massachusetts Department of Conservation and Recreation
  - iii. Program Specialist for the National Flood Insurance Program at the Federal Emergency Management Agency, Region 1 Office.

# 8. OVERLAY DISTRICTS

Master Planned Development (MPD)

## 8.3 MASTER PLANNED DEVELOPMENT (MPD)

### 1. Intent

- a. To implement recommendations of SomerVision for transformational reDEVELOPMENT.
- b. To implement design-based neighborhood and station area plans called for by SomerVision.

### 2. Purpose

- a. To require a Master Plan Special Permit for all DEVELOPMENT requiring SUBDIVISION.
- b. To require a Master Plan Special Permit for the coordinated DEVELOPMENT of two or more LOTS.
- c. To permit real property that is not subject to an approved Master Plan Special Permit to develop by Special Permit.
- d. To permit DEVELOPMENT in accordance with zoning districts or dimensional standards that would not otherwise be available to real property outside of the MPD overlay.
- e. To require thoroughfares and CIVIC SPACE developed in each sub area to be dedicated to the public.
- f. To require buildings developed in each sub area to be environmental sustainable.
- g. To require that any off-STREET motor vehicle parking be provided in underground commercial PARKING STRUCTURES.

### 3. Applicability

- a. The section is applicable to all real property within the Master Planned DEVELOPMENT (MPD) overlay district as shown on the maps of the Official Zoning Atlas of the City of Somerville.
- b. The provisions of this Section supplement or supersede the provisions of the districts upon which it is superimposed. Where the provisions of this Section conflict with those found elsewhere in this Ordinance, the provisions of this Section apply.

### 4. Urban Design

- a. The Planning Board shall adopt an Urban Design Framework for each sub-area specified in this Section.
- b. An Urban Design Framework may be adopted as part of a more comprehensive neighborhood plan.
- c. An Urban Design Framework must include, but may not be limited to, the intended alignment and connectivity of THOROUGHFARES, ideal location and type of CIVIC SPACES, and identification of advantageous SITES for different BUILDING TYPES permitted by the regulatory maps for each sub-area.

### 5. Development Review

- a. General
  - i. DEVELOPMENT review is subject to the provisions of Article 15: Administration of this Ordinance.

- ii. All DEVELOPMENT, excluding NORMAL MAINTENANCE, requires the submittal of a development review application to the BUILDING OFFICIAL and the issuance of a Certificate of Zoning Compliance prior to the issuance of a BUILDING Permit or Certificate of Occupancy.
- b. Master Planned DEVELOPMENT
  - i. Proposed DEVELOPMENT involving the SUBDIVISION of a DEVELOPMENT SITE or the DEVELOPMENT of two (2) or more LOTS requires a Master Plan Special Permit as a prerequisite to the DEVELOPMENT review for the SUBDIVISION or individual LOT.
  - ii. In addition to the review criteria for all Special Permits specified in §15.2.1.e. Review Criteria, the review board shall make findings considering the following in its discretion to approve or deny a Master Plan Special Permit:
    - a). Consistency with the approved Urban Design Framework for the sub-area where the DEVELOPMENT SITE is located.
    - b). The proposed alignment and connectivity of the THOROUGHFARE network.
    - c). The GROSS FLOOR AREA allocated to different USE categories.
    - d). Mitigation proposed to alleviate any adverse impacts on utility infrastructure.
    - e). Proposed DEVELOPMENT phasing.
    - f). Proposed on-STREET parking to address demand by customers of Retail Sales, Food & Beverage, or Commercial Services PRINCIPAL USES.
  - iii. Following the approval of a Master Plan Special Permit, DEVELOPMENT of individual LOTS is permitted in accordance with the zoning districts shown on the regulatory maps for each sub-area.
  - iv. Previously permitted DEVELOPMENT may be included in a DEVELOPMENT SITE, provided that the date of the first certificate of occupancy for the subject real property is within two (2) years of the submittal date of the development review application.
  - v. Changes to a development review application subject to an approved Master Plan Special Permit are subject to §15.2.4 Plan Revision.
- c. Contributing LOTS
  - i. Unless otherwise specified, real property that is not subject to an approved Master Plan Special Permit may be developed in accordance with the zoning districts shown on the regulatory maps for each sub-area by Special Permit.
  - ii. In addition to the review criteria for all Special Permits specified in §15.2.1.e. Review Criteria, the review board shall make findings considering



the following in its discretion to approve or deny a special permit authorizing DEVELOPMENT of a contributing LOT:

- a). Consistency with the approved Urban Design Framework for the sub-area where the subject property is located.
- iii. DEVELOPMENT of real property as an individual contributing LOT is prohibited unless the Planning Board had adopted an Urban Design Framework for the sub-area where the subject property is located.
- iv. DEVELOPMENT of real property as an individual contributing LOT is prohibited for any LOT subject to an approved Master Plan Special Permit.
- d. Site Plan Approval
  - i. In addition to the review criteria for all Site Plan Approval specified in §15.3.2.e. Review Criteria, the review board shall make findings considering the following:
    - a). Consistency with the approved Urban Design Framework for the sub-area where the subject property is located.
    - b). Conformance with an approved Master Plan Special Permit and any other Special Permits applicable to the subject LOT.
  - e. Compliance with other Permits
    - i. The SUBDIVISION of any DEVELOPMENT SITE, the construction or reconstruction of any THOROUGHFARE, and the DEVELOPMENT of LOT in the MPD overlay district must comply with any approved Master Plan Special Permit and any approved Special Permits, as applicable, for the subject DEVELOPMENT SITE.

**6. In-Lieu Payments**

- a. Master Planned DEVELOPMENT
  - i. The Planning Board may permit an in lieu payment for up to ten percent (10%) of the CIVIC SPACE required in each sub-area by Special Permit.
    - a). In addition to the review criteria for all Special Permits specified in §15.2.1.e. Review Criteria, the review board shall make findings considering the following in its discretion to approve or deny a special permit authorizing a payment in lieu of CIVIC SPACE:
      - i). The goals and objectives of the City of Somerville OPEN SPACE Plan.
      - ii). The availability and suitability of LOTS within a DEVELOPMENT SITE for DEVELOPMENT as a CIVIC SPACE.
      - iii). The plausible availability of SITES located elsewhere in the city that are suitable for DEVELOPMENT as CIVIC SPACE.
      - iv). The need for funding to improve or maintain existing CIVIC SPACES, particularly

athletic fields, located elsewhere in the city.

- b). The in-lieu payment for CIVIC SPACE is calculated as  $(A*B)$  where:
  - i). A is the square footage of CIVIC SPACE not provided; and
  - ii). B the average cost to acquire, design, and develop land as a CIVIC SPACE.
- b. Contributing Lots
  - i. The Planning Board may permit an in lieu payment for up to one hundred percent (100%) of the CIVIC SPACE required in each sub-area by Special Permit.
    - a). In addition to the review criteria for all Special Permits specified in §15.2.1.e. Review Criteria, the review board shall make findings considering the following in its discretion to approve or deny a special permit authorizing a payment in lieu of CIVIC SPACE:
      - i). Consistency with the approved Urban Design Framework, as amended.
      - ii). If receipt of an in-lieu payment is advantageous to the City in creating or preserving CIVIC SPACE as compared to the CIVIC SPACE that would have been otherwise provided.
    - b). The in-lieu payment for CIVIC SPACE is calculated as  $(A*B)$  where:
      - i). A is the square footage of CIVIC SPACE not provided; and
      - ii). B the average cost to acquire, design, and develop land as a CIVIC SPACE.
  - ii. The Planning Board may permit an in lieu payment for up to one hundred percent (100%) of the required non-residential floor area by Special Permit.
    - a). In addition to the review criteria for all Special Permits specified in §15.2.1.e. Review Criteria, the review board shall make findings considering the following in its discretion to approve or deny a special permit authorizing a payment in lieu of commercial floor area:
      - i). Consistency with the approved Boynton Yards Urban Design Framework, as amended.
      - ii). If receipt of an in-lieu payment is advantageous to the City in creating or preserving non-residential floor space as compared to the non-residential floor space that would have been otherwise provided.
    - b). The in-lieu payment for commercial floor area is calculated as  $10*(A*B)$  where:
      - i). A is the square footage of commercial floor area not provided; and

## 8. OVERLAY DISTRICTS

Master Planned Development (MPD)

- ii). B is the difference between the price per square foot of non-residential floor area rented or sold over the previous twelve (12) months and the average price per square foot of the market-rate dwelling units proposed for the DEVELOPMENT.

### 7. Thoroughfares & Civic Spaces

- a. Required and recommended THOROUGHFARES and CIVIC SPACES are shown on the regulating maps for each sub-area.
  - i. Required THOROUGHFARES and CIVIC SPACES are mandatory and necessary to implement the approved plan for each sub-area.
  - ii. Recommended THOROUGHFARES and CIVIC SPACES are ideal, but not mandatory.
- b. THOROUGHFARES and CIVIC SPACES are subject to the provisions of Article 13: PUBLIC REALM of this Ordinance.
- c. All THOROUGHFARES and CIVIC SPACES must be dedicated to the public in perpetuity by a covenant or other deed restriction.
- d. CIVIC SPACE created through EASEMENT or decommissioning of an existing THOROUGHFARE or other ABUTTING right-of-way may be counted toward the required amount of CIVIC SPACE.

### 8. Development Standards

- a. Sustainable DEVELOPMENT
  - i. DEVELOPMENT of any new PRINCIPAL BUILDING or the MODIFICATION of any existing BUILDING TYPE greater than twenty five thousand (25,000) in GROSS FLOOR AREA within any sub-area of the MPD overlay district must be a NET ZERO BUILDING or LEED Platinum certifiable.

### 9. Parking & Mobility

- a. Type
  - i. Unless otherwise specified, MOTOR VEHICLE PARKING must be provided as underground STRUCTURED PARKING. All other types of parking are prohibited.
- b. Parking Maximums
  - i. The maximum number of OFF-STREET PARKING SPACES and RESERVED PARKING spaces permitted for each sub-area is specified in the provisions for each sub-area.
  - ii. The maximum number of OFF-STREET PARKING SPACES and RESERVED PARKING spaces permitted in each sub-area is reduced by the number of OFF-STREET PARKING SPACES and RESERVED PARKING spaces provided on any LOT in each sub-area.
- c. Parking Relief
  - i. The maximum number of OFF-STREET PARKING SPACES in each sub-area may be exceeded by Special Permit.
    - a). In addition to the review criteria for all Special

Permits specified in §15.2.1.e. Review Criteria, the review board shall make findings considering the following in its discretion to approve or deny a special permit authorizing an increase in the maximum number of OFF-STREET PARKING SPACES serving DEVELOPMENT within the MPD overlay district:

- i). That the amount of commercial floor space included in the proposal has resulted in an increase in the estimated parking demand necessary for the full build out of DEVELOPMENT.
- b). The Planning Board shall USE a demand model provided by the Director of Mobility to determine the appropriate number of parking spaces necessary to meet the increased demand.
- c). The Planning Board shall require a MOBILITY MANAGEMENT ASSOCIATION (i.e. Transportation Management Agency) to be constituted by a date of its choosing as a condition of the Special Permit approval.
  - i). The MOBILITY MANAGEMENT ASSOCIATION must be empowered to set the prices and policies for the rent or lease of any vehicular parking operated as a commercial service USE within each sub-area.
- ii. The maximum number of RESERVED PARKING SPACES may be exceeded with the payment of a fee.
  - a). The Planning Board shall establish and annually update a fee schedule based on the recommendations of the Director of Mobility in relation to the estimated cost to build STRUCTURED PARKING and the cost of offsetting the impact of UNSHARED PARKING.
- iii. The Planning Board shall establish an expiration date for any parking spaces approved but not built within a particular time frame as a condition of the approved Special Permit.
- d. Parking ACCESS
  - i. ACCESS for motor vehicles, loading, and service to new BLOCKS and individual LOTS must be from an ALLEY. The configuration of ALLEYS internal to a BLOCK must conform to §10.1.5 Alley Access.

**10. Assembly Square (ASQ) Sub-Area**

- a. Reserved

# 8. OVERLAY DISTRICTS

## Master Planned Development (MPD)

### 11. Boynton Yards (BY) Sub-Area

- a. Intent
  - i. To implement the Boynton Yards Urban Design Framework adopted by the Planning Board.
- b. Purpose
  - i. To permit denser DEVELOPMENT than would otherwise be permitted in the Mid-Rise district.
  - ii. To permit taller and denser DEVELOPMENT than would otherwise be permitted in the HIGH-RISE district.
  - iii. To require a minimum percentage of developed floor space to be set aside for occupancy by non-residential PRINCIPAL USES.
  - iv. To constrain the supply of motor vehicle parking spaces to encourage the USE of public transit, bicycles, and walking in lieu of driving.
- c. Applicability
  - i. The section is applicable to all real property shown on Map 8.3.12 (a).
  - ii. Zoning districts shown on map 8.3.12 (a) supercede those shown on the maps of the Official Zoning Atlas of the City of Somerville for DEVELOPMENT complying with the provisions of the BY sub-area.
- d. THOROUGHFARE Network
  - i. Required and recommended THOROUGHFARES are shown on Map 8.3.12 (b).
- ii. The center line of any required THOROUGHFARE may be moved up to twenty (25) feet, so long as:
  - a). the center line of West Ward STREET is at least one hundred and forty (140) feet from both reference points along the MBTA right-of-way;
  - b). West Ward STREET intersects with Webster Avenue in the west and Harding STREET in the east;
  - c). the center line of South STREET is at least one hundred and forty (140) feet from both reference points along the municipal boundary with Cambridge;
  - d). South STREET intersects with Webster Avenue in the west;
  - e). all required THOROUGHFARES intersect with other THOROUGHFARES, forming a network; and
  - f). all intersections are at least one hundred (100) feet from any other intersection, unless granted a WAIVER by the Planning Board.
- e. Build Out Standards
  - i. General
    - a). DEVELOPMENT SITES subject to approved Master Plan Special Permit may comply with the following standards in aggregate rather than for each individual LOT by Master Plan Special Permit.

**Map 8.3.11 (a) BY Sub-Area Boundary and Superceding Zoning Districts**

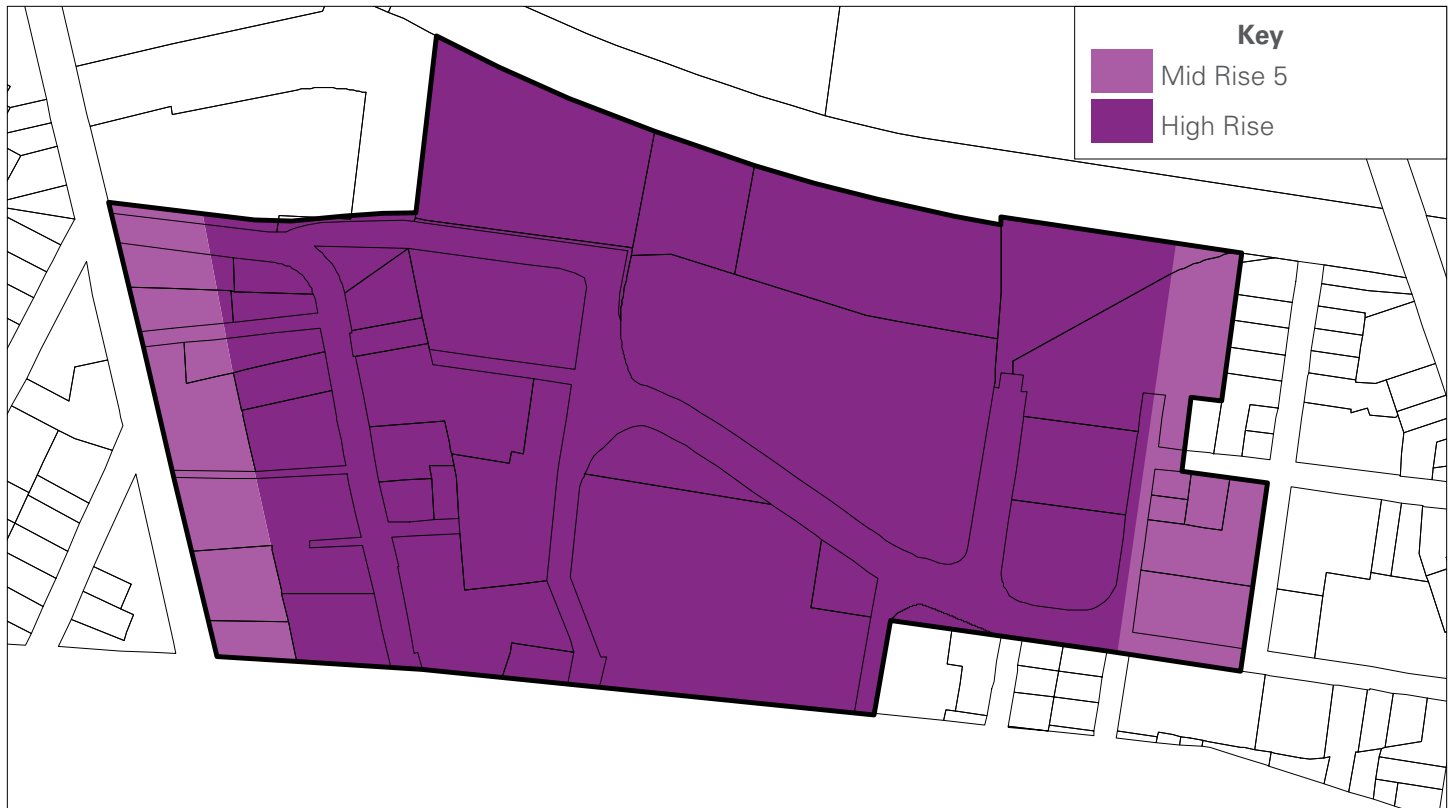

## 8. OVERLAY DISTRICTS

### Master Planned Development (MPD)

- ii. CIVIC SPACE
  - a). At least twenty percent (20%) of each DEVELOPMENT SITE, excluding THOROUGHFARES, must be provided as one or more CIVIC SPACES.
  - b). A CIVIC SPACE, of at least fifty-two thousand (52,000) square feet, must be provided, ABUTTING both West Ward STREET and South STREET, within the required CIVIC SPACE area indicated on Map 8.3.12 (b) and may be developed as a public common or a public square CIVIC SPACE type. See Article 11 PUBLIC REALM for more information.
- iii. Commercial Floor Area
  - a). At least sixty percent (60%) of the floor space of any building must be dedicated to non-residential USES, excluding Auto-Oriented and Industrial PRINCIPAL USES.
  - b). At least five percent (5%) of the total commercial floor area required by §8.3.11.e.ii must be dedicated to Arts & Creative Enterprise PRINCIPAL USES.
  - c). At least five percent (5%) of the total commercial floor area required by §8.3.11.e.ii or twenty thousand (20,000) square feet, whichever is less, and no less than ten thousand (10,000) square feet must be
    - dedicated to a Community Center PRINCIPAL USE.
- d). At least three hundred and seventy five (375) square feet of commercial space must be provided for each DWELLING UNIT.
- e). Any DEVELOPMENT SITE including LOT MBL 96/A/6 must provide at least one hundred thousand (100,000) square feet of space dedicated to Arts & Creative Enterprise PRINCIPAL USES.
- f. Building Standards
  - i. The standards of Table 8.3.11 supercede specific dimensional standards for BUILDING TYPES permitted by the zoning district shown on the regulating maps of this Section.
- g. Parking & Mobility
  - i. The maximum number of OFF-STREET PARKING SPACES in the BY sub-area may not exceed one thousand five hundred (1,500) spaces.
  - ii. Up to three hundred (300) OFF-STREET PARKING SPACES may be provided as RESERVED PARKING SPACES.
    - a). CAR-SHARE PARKING spaces are exempt.
  - iii. ACCESSORY parking for customers of retail sales or food & beverage service USES is prohibited for real property in any MR district shown on Map 8.3.11 (a), but may be provided for employees.
  - iv. OFF-STREET motor vehicle parking spaces may be provided as SURFACE PARKING on a revolving two

**Map 8.3.11 (b) Thoroughfars & Civic Spaces**

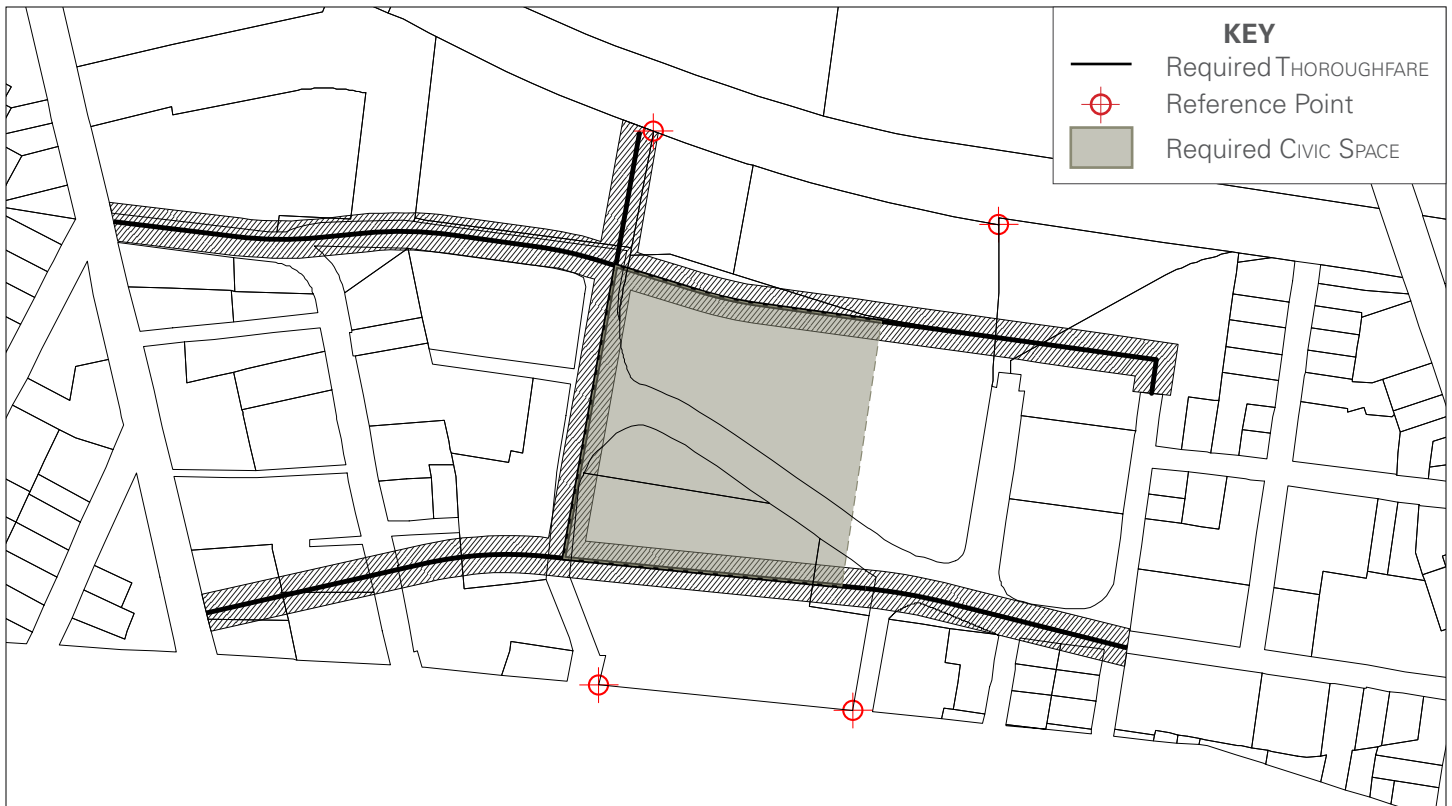

# 8. OVERLAY DISTRICTS

## Master Planned Development (MPD)

(2) year basis for real property in any HR district shown on Map 8.3.11 (a) by Special Permit.

- a). In addition to the review criteria for all Special Permits specified in §15.2.1.e. Review Criteria, the review board shall make findings considering the following in its discretion to approve or deny a special permit authorizing an interim SURFACE PARKING LOT:
- i). Documented un-met demand for parking;
  - ii). The DEVELOPMENT schedule and phasing for DEVELOPMENT subject to a Mster Plan Special Permit;
  - iii). The capacity of the local THOROUGHFARE network providing ACCESS to the SITE; and
  - iv). The impact of the PARKING LOT on pedestrian, bicycle, and motor vehicle traffic and circulation patterns in the neighborhood.

**Table 8.3.11 Superseding Dimensional Standards**

	MR5	HR
<b>LOT Standards</b>		
OPEN SPACE (min)	none	none
<b>Massing &amp; Height</b>		
Building Height, Stories (min)	--	6 stories
Building Height, Stories & Feet (max)	--	--
General Building	--	none
Commercial Building	--	none
Lab Building	--	none
Mid-Rise Podium Tower	--	--
POINT TOWER	--	none
BLOCK Building	--	--
TOWER(s)	--	none
Building Height, Feet (max)	--	--
General Building	--	none
Commercial Building	--	none
Lab Building	--	none
Mid-Rise PODIUM TOWER	--	--
POINT TOWER	--	none
BLOCK Building	--	--
PODIUM	--	--
TOWER(s)	--	none
<b>USES &amp; FEATURES</b>		
GROSS FLOOR AREA per DU (min)	none	none



**12. Brickbottom (BB) Sub-Area**

- a. Reserved

## **8. OVERLAY DISTRICTS**

Master Planned Development (MPD)

### **13. Grand Junction (GJ) Sub-Area**

- a. Reserved

**14. Inner Belt (IB) Sub-Area**

- a. Reserved



## 8. OVERLAY DISTRICTS

Master Planned Development (MPD)

### g. Residential Tower

A large FLOOR PLATE, multi STORY PRINCIPAL BUILDING TYPE composed of a residential TOWER above a mid-rise general BUILDING serving as a PODIUM. The PODIUM defines the PUBLIC REALM, provides GROUND STORY commercial space or amenities for residents, and may incorporate STRUCTURED PARKING.

The following images are examples of the residential TOWER BUILDING TYPE and are intended only for illustrative purposes.

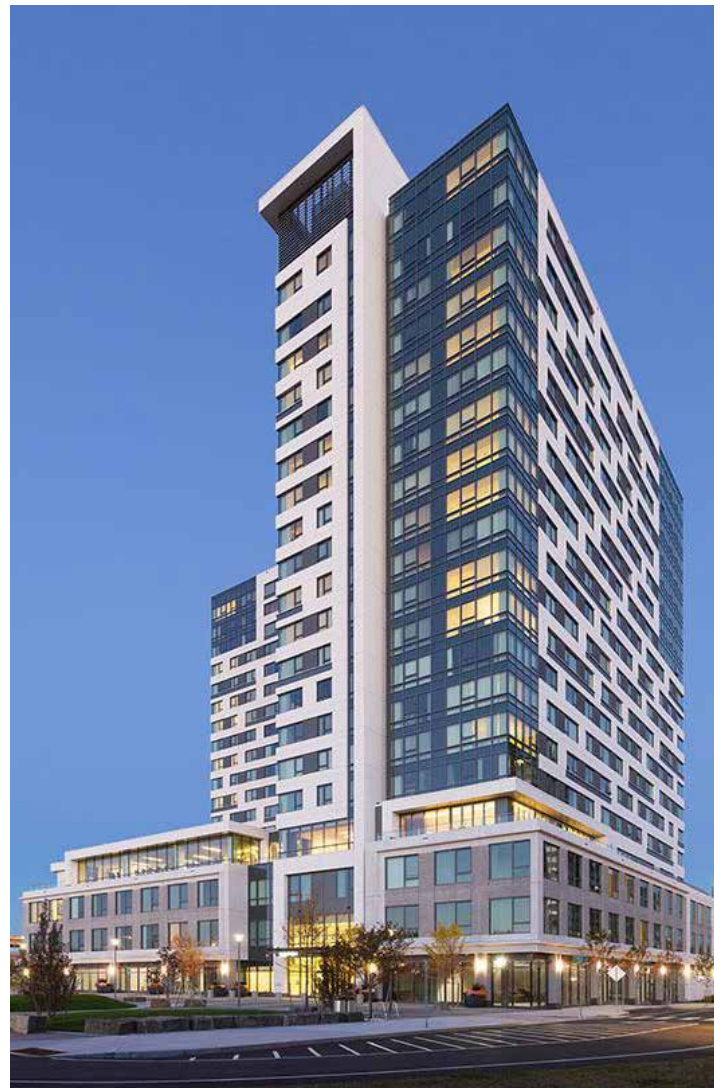

# 8. OVERLAY DISTRICTS

Master Planned Development (MPD)

## g. Residential Tower (continued)

### i. Lot Standards

### ii. BUILDING Placement

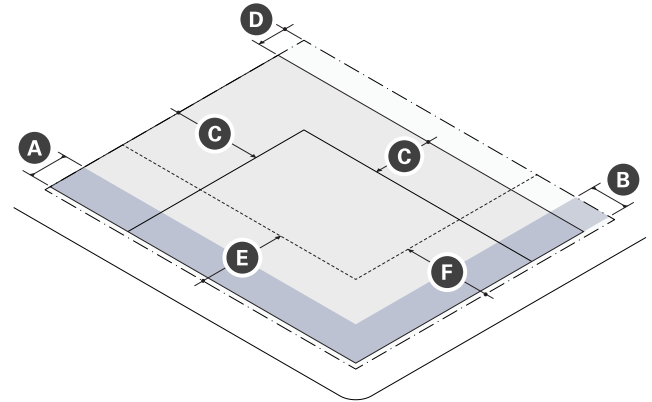
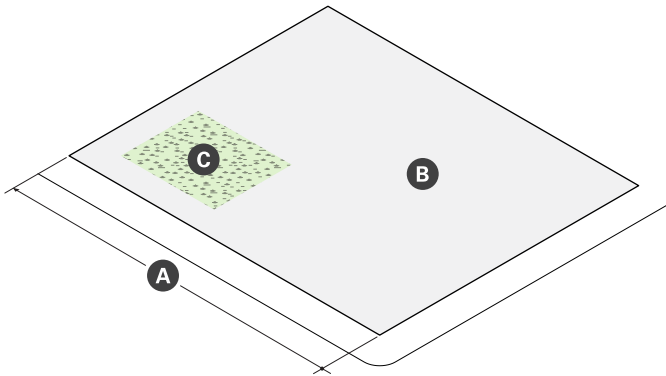

Lot Dimensions	
<b>A</b> Lot WIDTH (min)	150 ft

Lot Development	
<b>B</b> Lot Coverage (max)	100%
GREEN SCORE	--
Minimum	0.20
Ideal	0.25
<b>C</b> Open Space (min)	15%

Building Setbacks		
<b>A</b> Primary Front SETBACK (min/max)	2 ft	15 ft
<b>B</b> Secondary Front SETBACK	2 ft	15 ft
<b>C</b> Side SETBACK (min)	--	
PODIUM	0 ft	
TOWER	30 ft	
<b>D</b> PODIUM Rear SETBACK (min)	--	
TOWER REAR SETBACK	0 ft	

Parking Setbacks	
<b>E</b> Primary & Secondary Front SETBACK, GROUND STORY (min)	30 ft



## g. Residential Tower (continued)

### iii. Massing & Height

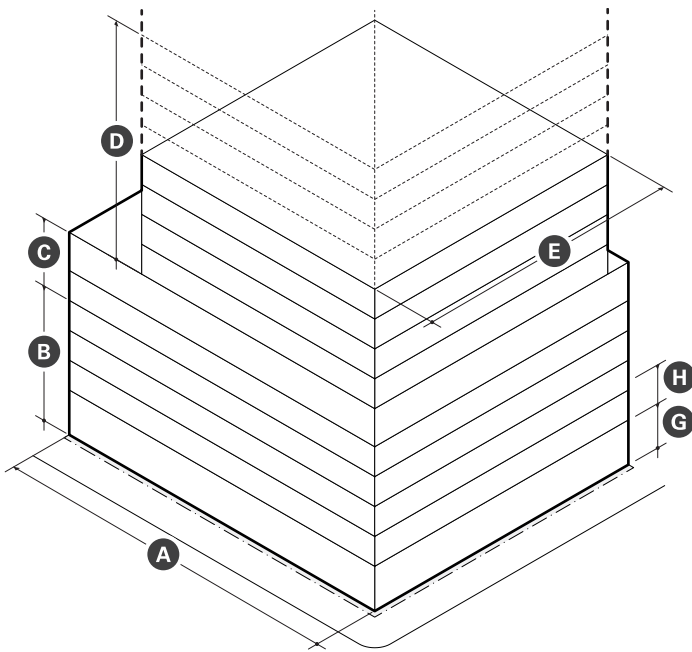

### iv. Uses & Features

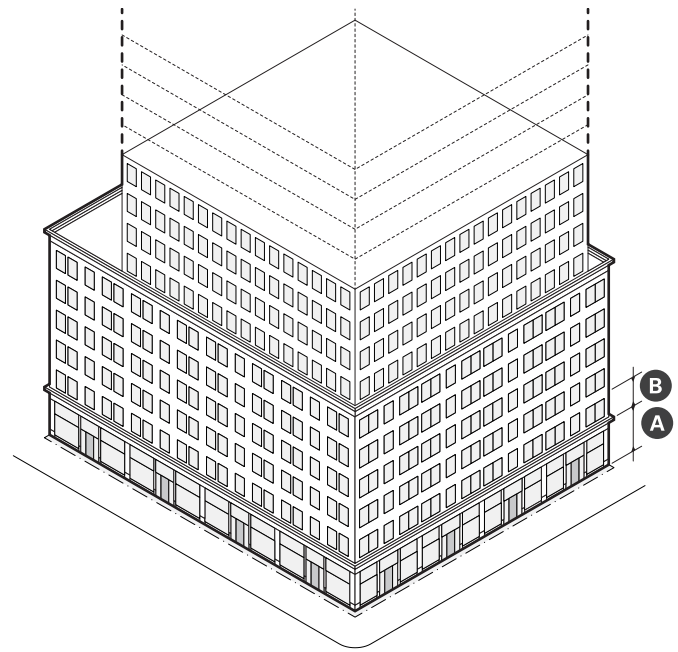

Main Mass	
<b>A</b> FACADE Build Out (min)	80%
FLOOR PLATE (max)	--
Up to 65 ft	45,000 sf
Up to 220 ft	20,000 sf
<b>B</b> GROUND STORY Height (min)	14 ft
<b>C</b> UPPER STORY Height (min)	10 ft
<b>D</b> Number of Stories (min)	3 stories
<b>E</b> TOWER Dimensions (max)	--
Width & Depth	150 ft
<b>F</b> BUILDING Height, Feet (max)	220 ft

Facade Composition		
<b>A</b> GROUND STORY FENESTRATION (min)	--	
Commercial	65%	
Residential	30%	50%
<b>B</b> UPPER STORY FENESTRATION (min/max)	30%	50%
BLANK WALL (max)	20 ft	

Use & Occupancy	
Commercial Space Depth (min)	30 ft
Outdoor AMENITY SPACE (min)	1/DU

# 8. OVERLAY DISTRICTS

## Master Planned Development (MPD)

### g. Residential Tower (continued)

- v. DEVELOPMENT Benefits
  - a). DEVELOPMENT is subject to the provisions of Article 12: DEVELOPMENT Benefits of this Ordinance. Where the provisions of this section conflict with those of Article 12, the provisions of Article 12 apply.
  - b). DEVELOPMENT of a residential TOWER must provide AFFORDABLE DWELLING UNITS as specified on Table 4.3.8 (a).
  - c). DEVELOPMENT of a residential TOWER must provide linkage payments as specified on Table 4.3.8 (b).

**Table 7.3.8. (a) Required ADUs**

Total DWELLING UNITS	Required ADUs
0 to 5 units	None
6 units	1 unit OR fractional buyout for 0.4 units
7 units	1 unit OR fractional buyout for 0.6 units
8 to 17 units	17.5% of units
18 or more units	20% of units

**Table 7.3.8. (b) Linkage**

Commercial GROSS FLOOR AREA	Affordable Housing Linkage	Employment Linkage
30,000 sf or less	None	None
Over 30,000 sf	\$10/sf	\$2.46/sf

## 8. OVERLAY DISTRICTS

### Master Planned Development (MPD)

- h. Building Standards
  - i. The standards of Table 8.3.11 supercede specific dimensional standards for BUILDING TYPES permitted in the HIGH-RISE district for DEVELOPMENT subject to an approved Master Plan Special Permit.

- i. Use Provisions
  - i. PRINCIPAL USES are exempt from the special permit required for large FLOOR PLATE USES by §9.1.9 except as follows:
    - a). Occupancy of any single GROUND STORY commercial space greater than ten-thousand (10,000) square feet in LEASABLE FLOOR AREA by any permitted Commercial Service or Retail

**Table 8.3.15 Superseding Dimensional Standards**

	HR
<b>LOT Standards</b>	
OPEN SPACE (min)	none
<b>Building SETBACKS</b>	
Primary Front SETBACKS (min/max)	0 ft   20 ft
Rear SETBACK (min)	none
<b>Massing &amp; Height</b>	
Building Width (max)	none
FLOOR PLATE (max)	--
General Building	--
Up to 65 ft	45,000 sf
Up to 220 ft	20,000 sf
Commercial Building	50,000 sf
Number of Stories (min)	4
Number of Stories (max)	--
General Building	none
Commercial Building	none
<b>TOWER Dimensions</b>	--
General Building	--
Width/Depth	150 ft
Building Height, Feet (max)	220 ft

**Table 7.3 (a) Superseding Permitted Uses**

Use Category Specific Use	HR
<b>Commercial Services</b>	
ASSEMBLY OR ENTERTAINMENT	P
PERSONAL SERVICES	P
<b>Recreation Services</b>	P
<b>Lodging</b>	
HOTEL OR HOSTEL	P
<b>Residential</b>	
GROUP LIVING (except as follows)	SP
COMMUNITY OR GROUP RESIDENCE	P
Dormitory, Fraternity or Sorority	N
HOMELESS SHELTER	N
Nursing Home/Assisted Living Facility	N
Rooming HOUSE	N
<b>Retail Sales</b>	
CONSUMER GOODS (except as follows)	P
PET STORE	P
<b>ACCESSORY USES</b>	
HOME OCCUPATIONS (as noted below)	--
HOME-BASED BUSINESS	P
Home Day Care	P
HOME OFFICE	P
<b>Urban Agriculture (as noted below)</b>	--
APICULTURE	P
AVICULTURE	P
COMMERCIAL FARMING	P
Residential Gardening	P
<b>Vehicle Parking, Accessory (except as follows)</b>	P
Home Business Vehicle Parking	N

P - Permitted    SP - Special Permit Required    N - Not Permitted

## 8. OVERLAY DISTRICTS

Master Planned Development (MPD)

Sales PRINCIPAL USE is prohibited.

- b). Occupancy of any single UPPER STORY commercial space greater than fifty-thousand square feet in LEASABLE FLOOR AREA by any Recreation Services PRINCIPAL USE requires a Special Permit in accordance with the same findings required in §9.1.9.
- j. Parking & Mobility
  - i. MOTOR VEHICLE PARKING may be provided as SURFACE PARKING on a revolving two (2) year basis by Special Permit.
    - a). In addition to the review criteria for all Special Permits specified in §15.2.1.e. Review Criteria, the review board shall make findings considering the following in its discretion to approve or deny a special permit authorizing an interim SURFACE PARKING LOT:
      - i). Documented un-met demand for parking;
      - ii). The DEVELOPMENT schedule and phasing for DEVELOPMENT subject to a Mster Plan Special Permit;
      - iii). The capacity of the local THOROUGHFARE network providing ACCESS to the SITE; and
      - iv). The impact of the PARKING LOT on pedestrian, bicycle, and motor vehicle traffic and circulation patterns in the neighborhood.

**16. Union Square (USQ) Sub-Area**

- a. Intent
  - i. To implement the Union Square Urban Design Framework adopted by the Planning Board.
  - ii. To maintain and enhance already established commercial areas in the core of Union Square.
  - iii. To redevelop underutilized areas within close walking distance to the future Union Square T-station with mixed-USE, mid-rise and HIGH-RISE DEVELOPMENT that will support the transformation of Union Square into an urban employment center.
  - iv. To implement the 2003 Union Square MASTER PLAN, the 2012 Union Square Revitalization Plan, and the 2016 Union Square Neighborhood Plan, as amended.
- b. Purpose
  - i. To permit DEVELOPMENT in accordance with the provisions of the MR4, MR5, CC, and HR districts for DEVELOPMENT.
  - ii. To require a minimum percentage of developed floor space to be set aside for occupancy by non-residential PRINCIPAL USES.
  - iii. To permit flexibility in compliance with certain dimensional standards than would otherwise be permitted by the zoning districts shown on the maps of the Official Zoning Atlas of the City of Somerville.
  - iv. To require DEVELOPMENT to be contextually sensitive to the existing neighborhood of Union Square.
  - v. To constrain the supply of MOTOR VEHICLE PARKING spaces to encourage the USE of public transit, bicycles, and walking in lieu of driving.
- c. Applicability
  - i. The section is applicable to all real property shown on Map 8.3.15.
  - ii. Zoning districts shown on map 8.3.15 supercede those shown on the maps of the Official Zoning Atlas of the City of Somerville for DEVELOPMENT complying with the provisions of Section 8.3 and the Union Square Sub-Area.
- d. Development Review
  - i. All DEVELOPMENT requires a Master Plan Special Permit as a prerequisite to the DEVELOPMENT review required for SUBDIVISION or the development of an individual LOT.
  - ii. Development of real property that is not subject to an approved Master Plan Special Permit (a 'contributing lot') is prohibited.
- e. Master Plan Standards
  - i. At least one (1) neighborhood park, with a minimum size of twenty-seven thousand (27,000) square feet, and one (1) plaza must be proposed in any master plan.
  - ii. At least twenty-five percent (25%) of the cumulative land area proposed as CIVIC SPACE in a master plan must be landscaped area compliant with §10.3 Landscaping.
- iii. At least fifty percent (50%) of the cumulative land area proposed as CIVIC SPACE in a master plan must be landscaped area compliant with §10.3 Landscaping or be covered by tree canopy at full maturity of the trees provided in each CIVIC SPACE.
- f. Build Out Standards
  - i. General
    - a). DEVELOPMENT SITES subject to a Master Plan Special Permit may comply with the following standards in aggregate rather than for each individual LOT by Master Plan Special Permit.
  - ii. CIVIC SPACE
    - a). At least twenty-five percent (25%) of each LOT, excluding ALLEYS and any land occupied by the MBTA's Union Square Green Line station, must be improved as follows:
      - i). At least seventy percent (70%) must be provided as one or more CIVIC SPACES.
      - ii). Up to thirty percent (30%) may be provided in the form of PUBLIC REALM improvements.
    - b). CIVIC SPACE created through EASEMENT or decommissioning of an existing THOROUGHFARE or other right-of-way may be counted toward the required amount of CIVIC SPACE.
  - iii. Commercial Floor Area
    - a). At least sixty percent (60%) of the GROSS FLOOR AREA of any building must be dedicated to non-residential USES, excluding Auto-Oriented and Industrial PRINCIPAL USES.
    - b). At least forty percent (40%) of the COMMERCIAL FLOOR AREA required by §8.3.15.e.i must be dedicated to either Office PRINCIPAL USES or Design SERVICES USES from the Arts & Creative Enterprise USE category.
    - c). At least five percent (5%) of the total GROSS FLOOR AREA required by §8.3.15.e.i must be dedicated to PRINCIPAL USES within the Arts & Creative Enterprise USE category.
    - d). At least three hundred and seventy five (375) square feet of commercial space must be provided for each DWELLING UNIT.
- g. Building Standards
  - i. Standards & Measurements
    - a). For any LOT with frontage on (2) two or more THOROUGHFARES with a difference in elevation of at least ten (10) feet, the GROUND STORY at the lower elevation is not included in the calculation of total number of stories.
  - ii. Stepback Exemption
    - a). Buildings developed in accordance with the

# 8. OVERLAY DISTRICTS

Master Planned Development (MPD)

MAP 8.3.15 USQ Sub-Area Boundary and Superceding Zoning Districts

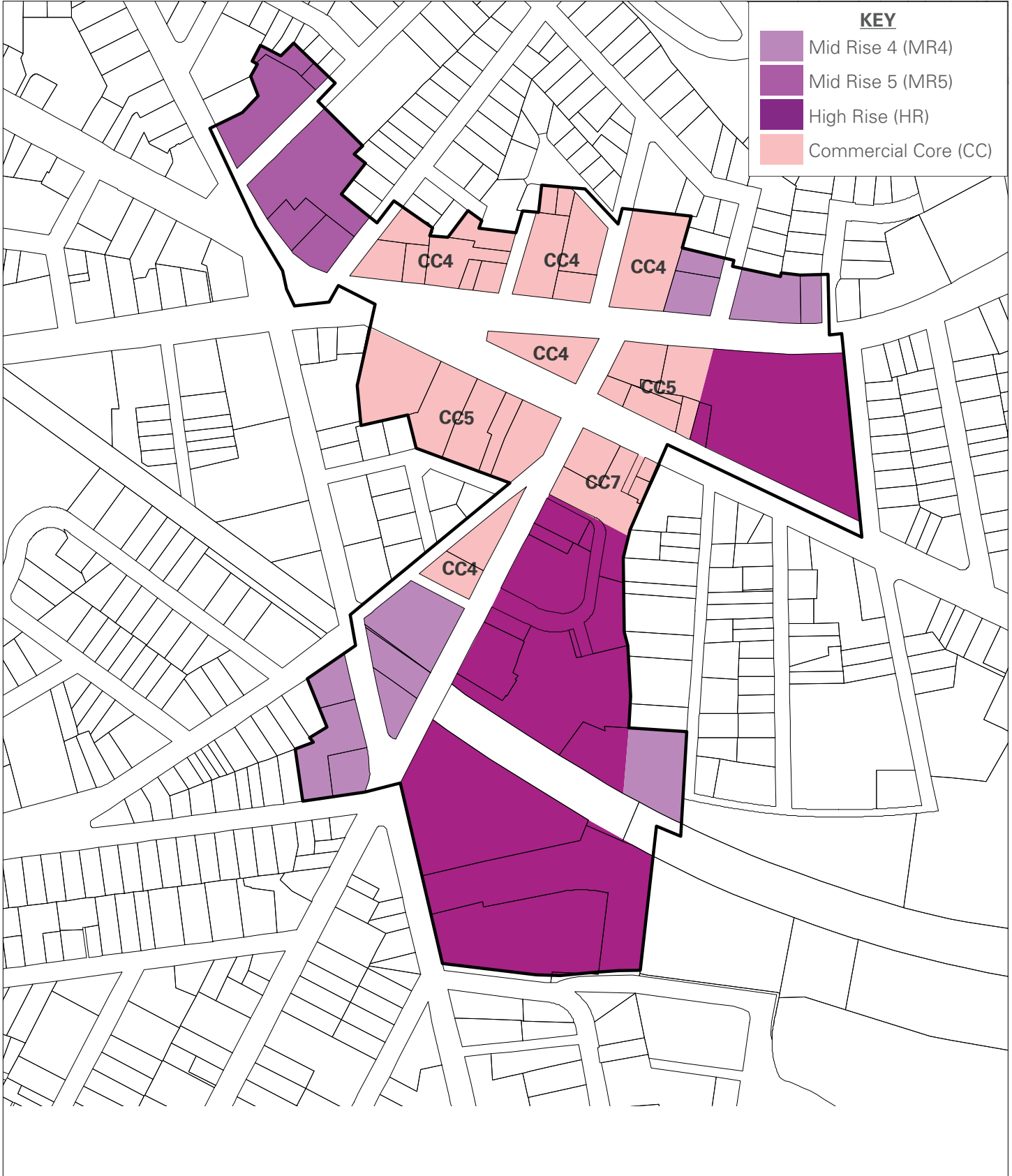



provisions of the MR5 and MR6 districts are exempt from UPPER STORY stepback requirements.

iii. Dimensional Compliance

- a). DEVELOPMENT may deviate up to five percent (5%) from the BUILDING WIDTH; POINT TOWER width, depth, diagonal, and FLOOR PLATE; FACADE build out; FENESTRATION; entrance spacing; and commercial space depth standards identified for each BUILDING TYPE in Section 5.1.10 by Special Permit.
- b). In addition to the review criteria for all Special Permits specified in §15.2.1.e. Review Criteria, the review board shall make findings considering the following in its discretion to permit DEVELOPMENT to deviate up to five (5) percent:
  - i). If the proposed deviation can provide a positive refinement of the massing of a BUILDING in context to its surroundings, improve FLOOR PLATE efficiency, provide for unique storefront design, or better address specific operational requirements of commercial tenants.

iv. Contextual Massing & Design

- a). For real property within the MR4 or MR5 districts as shown on Map 8.3.15, any General BUILDING ON a CORNER LOT may be designed according to the standards of the Apartment BUILDING TYPE along the secondary frontage in the following circumstances:
  - i). The CORNER LOT has a secondary FRONT LOT LINE over one hundred and fifty (150) feet in width; and
  - ii). The BUILDING has GROUND STORY commercial space along the primary frontage and for at least the first sixty (60) feet of the secondary frontage, measured from the intersection of the FRONT LOT LINES.
- b). For real property within the HIGH-RISE district as shown on Map 8.3.15, the UPPER STORIES of any BUILDING that exceeds five (5) stories in height must step back at either the 3rd, 4th, or 5th STORY at least ten (10) feet from the FACADE of the stories below for any BUILDING fronting Somerville Avenue, Washington STREET, Prospect STREET, or Webster Avenue and at least thirty (30) feet from the FACADE of the stories below for any BUILDING fronting Merriam STREET.
- c). For real property within the HIGH-RISE district as shown on Map 8.3.15, any Mid-Rise Podium Tower BUILDING ON a LOT directly fronting onto Somerville Avenue, Washington STREET, or

Merriam STREET the maximum building height is limited to ten (10) stories.

- d). Notwithstanding the maximum heights indicated for the Mid-Rise Podium Tower BUILDING TYPE, any Mid-Rise Podium Tower on a LOT fronting onto a CIVIC SPACE that fronts onto Prospect STREET may be built to twenty-five (25) stories and two hundred and eighty-six (288) feet.
- e). For real property within the Commercial Core district as shown on Map 8.3.15, the maximum height of any BUILDING ON a LOT WITH NORTH-FACING frontage along Somerville Avenue directly opposite of Union Square Plaza is limited to seventy-five (75) feet. Together with any mechanical penthouses on such a BUILDING, the total height is limited to eighty-five (85) feet, except as follows:
  - i). Mechanical penthouses must be set back a minimum distance from the FACADE equal to the height of the pentHOUSE
  - ii). The Planning Board may approve the extension of rooftop mechanical elements above the aforementioned limit, provided that (a) the Board finds that such additional height is the minimum necessary to achieve the desired objective, taking into account other important zoning goals such as energy efficiency and sustainability, will not create unreasonable shadow or other visual impacts, and cannot otherwise reasonably be addressed within the proposed height and (b) the additional height of such rooftop mechanical elements must be limited to five (5) additional feet; and (c) such rooftop mechanical elements must be located to the south of the centerline of the BUILDING roof.
- h. DEVELOPMENT Standards
  - i). For real property with a frontage on Everett STREET, luminaries located in the FRONTAGE AREA must be provided with sensors, timers, or other means to automatically reduce the LUMENS emitted by at least thirty percent (30%) beginning one hour after the close of business of the GROUND STORY tenant until 7:00am. Lighting required by the Massachusetts State BUILDING Code is exempt.
  - ii). Sound emanating from rooftop mechanical equipment must be minimized to every extent practicable including, but not limited to, the location and sizing of equipment, the selection of equipment, and sound attenuation measures.
  - iii). At a minimum, rooftop mechanical equipment

## 8. OVERLAY DISTRICTS

### Master Planned Development (MPD)

must not exceed ambient noise levels at ground level measured at the property line or cause a noise disturbance as defined by the Somerville Code of Ordinances Article VII, Division 2, Section 9-114.

- iv. The review board shall require an acoustical report, prepared by a professional acoustical engineer and including field measurements, demonstrating compliance with all applicable noise standards to be submitted to the Building Official prior to the issuance of a Certificate of Occupancy as a condition of any Site Plan Approval for a Commercial Building or Laboratory Building.
- i. Parking & Mobility
  - i. The maximum number of OFF-STREET PARKING SPACES in the BY sub-area may not exceed one thousand five hundred (1,500) spaces.
  - ii. Up to three hundred (300) OFF-STREET PARKING SPACES may be provided as RESERVED PARKING SPACES.
    - a). CAR-SHARE PARKING spaces are exempt.
  - iii. ACCESSORY parking for customers of retail sales or Food & Beverage Service USES is prohibited for real property in any MR district shown on Map 8.3.11 (a), but may be provided for employees.
  - iv. Off-STREET motor vehicle parking spaces may be provided as SURFACE PARKING on a revolving two (2) year basis for real property in any HR district shown on Map 8.3.11 (a) by Special Permit.
    - a). In addition to the review criteria for all Special Permits specified in §15.2.1.e. Review Criteria, the review board shall make findings considering the following in its discretion to approve or deny a special permit authorizing an interim SURFACE PARKING LOT:
      - i). Documented un-met demand for parking;
      - ii). The DEVELOPMENT schedule and phasing for DEVELOPMENT subject to a Mster Plan Special Permit;
      - iii). The capacity of the local THOROUGHFARE network providing ACCESS to the SITE; and
      - iv). The impact of the PARKING LOT on pedestrian, bicycle, and motor vehicle traffic and circulation patterns in the neighborhood.

**17. Union Square East (USQE) Sub-Area**

- a. Reserved

# 8. OVERLAY DISTRICTS

Master Planned Development (MPD)

## 9 USE PROVISIONS

<b>9.1</b>	<b>GENERAL.....</b>	<b>413</b>
	General	413
	Applicability	413
	Development Review	413
	Protected Uses	413
	Classification of Uses	413
	Category Designation	413
	Use Restrictions	413
	Pedestrian Street Restrictions	413
	Large Floor Area Uses	413
	Outdoor Storage & Display	414
<b>9.2</b>	<b>USE DEFINITIONS &amp; STANDARDS.....</b>	<b>420</b>
	General	420
	Arts & Creative Enterprise Use Categories	420
	Auto-Oriented Use Categories	421
	Cannabis Establishment Use Categories	422
	Civic & Institutional Use Categories	423
	Commercial Services Use Categories	424
	Food & Beverage Service Use Categories	428
	Industrial Use Categories	428
	Lodging Use Categories	430
	Office Use Categories	430
	Residential Use Categories	431
	Retail Sales Use Categories	432
	Urban Agriculture Use Categories	433
	Accessory Use Categories	434





## 9.1 GENERAL

### 1. General

- a. The USE of real property is permitted as specified on Table 9.1.1.
- b. USE categories not identified on Table 9.1.1 are prohibited.
- c. Real property may have one or more principal and one or more ACCESSORY USES.

### 2. Applicability

- a. The continuation of any USE that existed prior to the establishment of zoning in Somerville or that complied with the Somerville Zoning Ordinance when the USE was established, but is non-compliant to a subsequent amendment of the Somerville Zoning Ordinance is permitted, subject to Article 14: Nonconformance.

### 3. Development Review

- a. The establishment of any USE, CHANGE IN USE of any STRUCTURE or land, and any expansion in the USE of land requires the submittal of a development review application to the BUILDING OFFICIAL.
- b. All USES must comply with any USE-specific standards applicable for each USE in §9.2 USE Definitions & Limitations.
- c. USES permitted by Special Permit require additional DEVELOPMENT review in accordance with §15.2.1 Special Permits.

### 4. Protected Uses

- a. This Ordinance does not restrict the USE of land or STRUCTURES for activities protected by M.G.L. Chapter 40A, Section 3. In cases where Table 9.1 indicates the USE of real property for a protected USE requires a special permit (SP) or is not permitted (N), that USE is permitted (P) and is subject only to the provisions for the appropriate BUILDING TYPE.

### 5. Classification of Uses

- a. USE Categories
  - i. This Ordinance classifies principal land USES into USE categories based on similar functional, product, or physical characteristics, the type and amount of activity, the manner of tenancy, the conduct of customers, how goods or services are sold or delivered, and likely impact on surrounding properties.
- b. Specific USE Types
  - i. Some categories are further broken into a list of individual USES. For example, under the CONSUMER GOODS category is ALCOHOL SALES, which is a more strictly regulated USE than others in this same category.

### c. Organization of Text & Tables

- i. USE categories are listed on Table 9.1 and ordered in the text of 9.2 USE Definitions & Standards using the same headings for organizational purposes.
- d. Some USE categories identify a list of individual USES that are regulated differently than other USES within the same category, despite their similarity. In this circumstance the specific USES are identified by text that reads 'the following USES are regulated differently' in 9.2 USE Definitions & Standards and 'except as follows' on the USE table.
- e. Some USE categories identify an exclusive list of individual USES that are permitted, where individual USES not identified are prohibited. This circumstance is identified by text that reads 'the specific USES are' in 9.2 USE Definitions & Standards and 'as noted below' on the USE table.

### 6. Category Designation

- a. The BUILDING OFFICIAL shall classify land USES based on the definitions of the USE category and individual USES listed in 9.2 USE Definitions & Standards.
- b. A USE classified into one category cannot also be classified in a different USE category.
- c. If a proposed USE is not listed in a USE category, but meets the definition of a USE category or is similar to a listed individual USE, the BUILDING OFFICIAL may consider the proposed USE part of that USE category and issue a written interpretation to document such a determination for subsequent applications in accordance with §15.4.3 Written Interpretation.
- d. When a proposed USE is not found to meet the definition of a USE category or be similar to a listed individual USE by the BUILDING OFFICIAL, the USE is prohibited.

### 7. Use Restrictions

- a. The USES permitted according to Table 9.1 may be limited or restricted from occupancy within certain BUILDING TYPES permitted for each district.
- b. Drive-up and drive-through USES are prohibited.

### 8. Pedestrian Street Restrictions

- a. The USES permitted according to Table 9.1.1 may be further limited for real property ABUTTING a PEDESTRIAN STREET. See the provisions for each zoning district for more information.

### 9. Large Floor Area Uses

- a. Unless otherwise specified, occupancy of any single commercial space greater than ten-thousand (10,000) square feet in LEASABLE FLOOR AREA by any permitted

## 9. USE PROVISIONS

### General

Auto-Oriented, Commercial Service, or Retail Sales use requires a Special Permit.

- i. In addition to the review criteria for all Special Permits specified in §15.2.1.e. Review Criteria, the review board shall make findings considering the following in its discretion to approve or deny a special permit authorizing an auto oriented, consumer service or retail sales USE over ten thousand (10,000) square feet in LEASABLE FLOOR AREA:
  - a). Compatibility with the intensity of activity associated with the surrounding land USES.
  - b). Capacity of the local THOROUGHFARE network providing ACCESS to the SITE and the impact on pedestrian, bicycle, and vehicular traffic and circulation patterns in the neighborhood.

### 10. Outdoor Storage & Display

- a. OUTDOOR STORAGE of equipment, inventory, materials, merchandise, supplies, or other items is prohibited, except in the Fabrication district, Commercial Industry district, and Tufts University special district.
- b. Unless otherwise specified, OUTDOOR DISPLAY of products and merchandise is prohibited.

# 9. USE PROVISIONS

General

**Table 9.1.1 Permitted Uses**

Use Category Specific Use	NR	UR	MR3	MR4	MR5	MR6	HR	FAB	CC	CI	CB	CIV	Use Specific Standards
<b>Arts &amp; Creative Enterprise</b>													
Artisinal Production	SP	SP	P	P	P	P	P	P	P	P	P	N	§9.2.2.a
Arts Exhibition	N	N	P	P	P	P	P	P	P	P	P	N	§9.2.2.b
Arts Sales or Services	SP	SP	P	P	P	P	P	P	P	P	P	N	§9.2.2.c
Co-Working	N	N	P	P	P	P	P	P	P	P	P	N	§9.2.2.d
Design Services	SP	SP	P	P	P	P	P	P	P	P	P	N	§9.2.2.e
Shared Workspaces or Arts Education	SP	SP	P	P	P	P	P	P	P	P	P	N	§9.2.2.f
Work/Live Creative Studio	N	N	N	N	N	N	N	SP	N	N	N	N	§9.2.2.g
<b>Auto-Oriented</b>													
Commercial Vehicle Repair or Maintenance	N	N	N	N	N	N	N	N	N	SP	SP	N	§9.2.3.a
Dispatch Service (except as follows)	N	N	N	N	N	N	N	N	N	P	P	N	§9.2.3.b
Towing Service	N	N	N	N	N	N	N	N	N	SP	SP	N	§9.2.3.b.i
Gasoline Station	N	N	N	N	N	N	N	N	N	N	N	N	§9.2.3.c
Motor Vehicle Parking (as noted below)	--	--	--	--	--	--	--	--	--	--	--	--	§9.2.3.d
Off-Site Accessory Parking	SP	SP	N	N	N	N	N	N	N	P	P	N	§9.2.3.d.i
Personal Vehicle Repair or Maintenance	N	N	N	N	N	N	N	N	N	SP	SP	N	§9.2.3.e
Vehicle Sales	N	N	N	N	N	N	N	N	N	SP	SP	N	§9.2.3.f
<b>Cannabis Establishment</b>													
Cannabis Cultivation	N	N	P	P	P	P	P	P	P	P	P	N	§9.2.4.b
Cannabis Product Manufacturing	N	N	N	N	N	N	N	P	N	P	N	N	§9.2.4.c
Cannabis Retail Sales	N	N	SP	SP	SP	SP	SP	N	SP	SP	SP	N	§9.2.4.d
Cannabis Research & Development	N	N	P	P	P	P	P	N	P	P	P	N	§9.2.4.e
Cannabis Testing Laboratory	N	N	P	P	P	P	P	N	P	P	P	N	§9.2.4.f

P - Permitted      SP - Special Permit Required      N - Not Permitted

# 9. USE PROVISIONS

General

**Table 9.1.1 Permitted Uses**

Use Category Specific Use	NR	UR	MR3	MR4	MR5	MR6	HR	FAB	CC	CI	CB	CIV	USE Specific Standards
<b>Civic &amp; Institutional</b>													
Community Center	N	N	P	P	P	P	P	P	P	N	N	N	§9.2.5.a
Hospital	N	N	SP	SP	SP	SP	SP	N	SP	SP	N	N	§9.2.5.b
Library	N	N	P	P	P	P	P	P	P	N	N	N	§9.2.5.c
Minor Utility Facility	SP	SP	SP	SP	SP	SP	SP	SP	SP	SP	SP	SP	§9.2.5.d
Major Utility Facility	N	N	N	N	N	N	N	N	N	N	N	N	§9.2.5.e
Museum	N	N	P	P	P	P	P	P	P	N	N	N	§9.2.5.f
Private Non-Profit Club or Lodge	N	N	SP	SP	SP	SP	SP	N	SP	N	N	N	§9.2.5.g
Public Service	P	P	P	P	P	P	P	P	P	P	P	P	§9.2.5.h
Religious & Educational Uses Protected by M.G.L. 40A. Sec. 3	P	P	P	P	P	P	P	P	P	P	P	P	§9.2.5.i
<b>Commercial Services</b>													
Animal Services (as noted below)	--	--	--	--	--	--	--	--	--	--	--	--	§9.2.6.a
Commercial Kennel	N	N	SP	SP	SP	SP	SP	N	SP	P	P	N	§9.2.6.a.i
Pet Grooming	N	N	P	P	P	P	P	N	P	P	P	N	§9.2.6.a.ii
Pet Day Care or Training	N	N	SP	SP	SP	SP	SP	N	SP	P	P	N	§9.2.6.a.iii
Veterinarian	N	N	SP	SP	SP	SP	SP	N	SP	P	P	N	§9.2.6.a.iv
Assembly or Entertainment	N	N	SP	SP	SP	SP	SP	N	SP	SP	SP	N	§9.2.6.b
Banking or Financial Services (except as follows)	N	N	P	P	P	P	P	N	P	P	P	N	§9.2.6.c
Personal Credit	N	N	SP	SP	SP	SP	SP	N	SP	SP	SP	N	§9.2.6.c.i
Broadcast or Recording Studio	N	N	P	P	P	P	P	P	P	P	P	N	§9.2.6.d
Building or Home Repair Services	N	N	SP	SP	SP	SP	SP	N	SP	P	P	N	§9.2.6.e
Business Support Services	N	N	P	P	P	P	P	N	P	P	P	N	§9.2.6.f
Caterer or Wholesale Food Production	N	N	SP	SP	SP	SP	SP	P	SP	P	P	N	§9.2.6.g
Day Care Services (as noted below)	--	--	--	--	--	--	--	--	--	--	--	--	§9.2.6.h
Adult Day Care Center	N	N	P	P	P	P	P	N	P	P	P	N	§9.2.6.h.i
Child Day Care Center	P	P	P	P	P	P	P	P	P	P	P	N	§9.2.6.h.ii
Educational Services	N	N	P	P	P	P	P	P	P	P	P	N	§9.2.6.i
Maintenance or Repair Services	N	N	P	P	P	P	P	N	P	P	P	N	§9.2.6.j

P - Permitted      SP - Special Permit Required      N - Not Permitted

# 9. USE PROVISIONS

General

**Table 9.1.1 Permitted Uses**

Use Category Specific Use	NR	UR	MR3	MR4	MR5	MR6	HR	FAB	CC	CI	CB	CIV	USE Specific Standards
<b>Personal Services (except as follows)</b>	N	N	P	P	P	P	P	N	P	P	P	N	§9.2.6.k
Body Art Services	N	N	SP	SP	SP	SP	SP	P	SP	P	P	N	§9.2.6.k.i
Fitness Services	N	N	P	P	P	P	P	P	P	P	P	N	§9.2.6.k.ii
Funeral Services	N	N	SP	SP	SP	SP	SP	N	SP	P	P	N	§9.2.6.k.iii
Health Care Services	N	N	SP	SP	SP	SP	SP	N	SP	SP	SP	N	§9.2.6.k.iv
Formula Personal Services	N	N	SP	SP	SP	SP	SP	SP	SP	SP	SP	N	§9.2.6.k.v
<b>Recreation Services</b>	N	N	SP	SP	SP	SP	SP	SP	SP	P	P	P	§9.2.6.l
<b>Vehicle Parking (as noted below)</b>	--	--	--	--	--	--	--	--	--	--	--	--	§9.2.6.m
Bike Share Parking	N	P	P	P	P	P	P	P	P	P	P	P	§9.2.6.m.i
Car Share Parking (3 or less)	N	P	P	P	P	P	P	P	P	P	P	N	§9.2.6.m.ii
Car Share Parking (4 or more)	N	SP	P	P	P	P	P	P	P	P	P	N	§9.2.6.m.ii
Commercial Parking	N	N	P	P	P	P	P	P	P	P	P	N	§9.2.6.m.iii
<b>Food and Beverage Services</b>													
Bar, Restaurant, or Tavern	N	N	P	P	P	P	P	N	P	P	P	N	§9.2.7.a
Bakery, Café, or Coffee Shop	N	N	P	P	P	P	P	N	P	P	P	N	§9.2.7.b
Formula Food or Beverage Establishment	N	N	SP	SP	SP	SP	SP	N	SP	SP	P	N	§9.2.7.c
<b>Industrial</b>													
Dry Cleaning or Laundry Services	N	N	N	N	N	N	N	N	N	SP	N	N	§9.2.8.a
Data Center	N	N	N	N	N	N	N	N	N	SP	N	N	§9.2.8.b
Manufacturing	N	N	N	N	N	N	N	P	N	P	N	N	§9.2.8.c
<b>Moving or Storage Services (except as follows)</b>	N	N	N	N	N	N	N	N	N	P	N	N	§9.2.8.d
Self Storage	N	N	N	N	N	N	N	N	N	SP	SP	N	§9.2.8.d.i
Recycling Collection	N	N	N	N	N	N	N	N	N	SP	N	N	§9.2.8.e
Salvage Yard	N	N	N	N	N	N	N	N	N	N	N	N	§9.2.8.f
Trucking or Transportation Depot	N	N	N	N	N	N	N	N	N	SP	N	N	§9.2.8.g
Wholesale Trade or Distribution	N	N	N	N	N	N	N	P	N	P	N	N	§9.2.8.h
<b>Lodging</b>													
Bed & Breakfast	SP	SP	SP	SP	SP	SP	SP	N	SP	N	N	N	§9.2.9.a
Hotel or Hostel	N	N	SP	SP	SP	SP	SP	N	SP	SP	SP	N	§9.2.9.b

P - Permitted      SP - Special Permit Required      N - Not Permitted

# 9. USE PROVISIONS

General

**Table 9.1.1 Permitted Uses**

Use Category Specific Use	NR	UR	MR3	MR4	MR5	MR6	HR	FAB	CC	CI	CB	CIV	USE Specific Standards
<b>Office</b>													
General Office	N	N	P	P	P	P	P	N	P	P	P	N	§9.2.10.a
Research and Development or Laboratory	N	N	P	P	P	P	P	N	P	P	P	N	§9.2.10.b
<b>Residential</b>													
Household Living	P	P	SP	SP	SP	SP	SP	N	N	N	N	N	§9.2.11.a
Group Living (except as follows)	SP	SP	SP	SP	SP	SP	SP	N	N	N	N	N	§9.2.11.b
Community or Group Residence	P	P	P	P	P	P	P	N	N	N	N	N	§9.2.11.b.i
Dormitory or Chapter House	N	SP	SP	SP	SP	SP	SP	N	N	N	N	N	§9.2.11.b.ii
Homeless Shelter	N	N	SP	SP	SP	SP	SP	N	N	N	N	N	§9.2.11.b.iii
Nursing Home/Assisted Living Facility	N	SP	SP	SP	SP	SP	SP	N	N	N	N	N	§9.2.11.b.iv
Rooming House	N	SP	SP	SP	SP	SP	SP	N	N	N	N	N	§9.2.11.b.v
<b>Retail Sales</b>													
Building/Home Supplies or Equipment	N	N	SP	SP	SP	SP	SP	N	SP	P	P	N	§9.2.12.a
Consumer Goods (except as follows)	P	P	P	P	P	P	P	N	P	P	P	N	§9.2.12.b
Alcohol Sales	N	N	SP	SP	SP	SP	SP	N	SP	SP	SP	N	§9.2.12.b.ii
Firearms Sales	N	N	N	N	N	N	N	N	N	N	N	N	§9.2.12.b.iv
Pet Store	N	N	SP	SP	SP	SP	SP	N	SP	SP	SP	N	§9.2.12.b.v
Formula Retail	N	N	SP	SP	SP	SP	SP	N	SP	SP	P	N	§9.2.12.c
Fresh Food Market or Grocery Store	P	P	P	P	P	P	P	N	P	SP	P	N	§9.2.12.d
Farm/Vendor Market	N	N	P	P	P	P	P	N	P	P	P	N	§9.2.12.e
<b>Urban Agriculture</b>													
Farming (as noted below)	--	--	--	--	--	--	--	--	--	--	--	--	§9.2.13.a
Commercial Farming	N	N	P	P	P	P	P	P	P	P	P	N	§9.2.13.a.i
Community Farming	P	P	P	P	P	P	P	P	P	P	P	P	§9.2.13.a.ii
Community Gardening	P	P	P	P	P	P	P	P	P	P	P	P	§9.2.13.b

P - Permitted      SP - Special Permit Required      N - Not Permitted



# 9. USE PROVISIONS

General

**Table 9.1.1 Permitted Uses**

Use Category Specific Use	NR	UR	MR3	MR4	MR5	MR6	HR	FAB	CC	CI	CB	CIV	USE Specific Standards
<b>Accessory Uses</b>													
Home Occupations (as noted below)	--	--	--	--	--	--	--	--	--	--	--	--	§9.2.14.c
Creative Studio	P	P	N	N	N	N	N	N	N	N	N	N	§9.2.14.c.ii
Hobby Kennel	SP	N	N	N	N	N	N	N	N	N	N	N	§9.2.14.c.iii
Home-Based Business	P	P	N	N	N	N	N	N	N	N	N	N	§9.2.14.c.iv
Home-Based Day Care	SP	N	N	N	N	N	N	N	N	N	N	N	§9.2.14.c.v
Home Office	P	P	P	P	P	P	P	N	N	N	N	N	§9.2.14.c.vi
<b>Urban Agriculture (as noted below)</b>													
Apiculture	P	P	P	P	P	P	P	N	N	N	N	N	§9.2.14.d.i
Aviculture	P	P	P	P	P	P	P	N	N	N	N	N	§9.2.14.d.ii
Commercial Farming	P	P	P	P	P	P	P	P	P	P	P	N	§9.2.14.d.iii
Residential Gardening	P	P	P	P	P	P	P	N	N	N	N	N	§9.2.14.d.iv
<b>Vehicle Parking, Accessory (except as follows)</b>													
Home Business Vehicle Parking	SP	SP	N	N	N	N	N	P	N	N	N	N	§9.2.14.e.i

P - Permitted      SP - Special Permit Required      N - Not Permitted

# 9. USE PROVISIONS

## Use Definitions & Standards

### 9.2 USE DEFINITIONS & STANDARDS

#### 1. General

- a. This section provides definitions for USE categories and individual USES and identifies standards applicable to either all USES within a category or specifically to an individual USE.
- b. In some cases, a PRINCIPAL USE may include ANCILLARY activities that are subordinate, customary, and incidental to the day-to-day operations of the PRINCIPAL USE. Such ANCILLARY activities do not require separate approval, but must comply with any standards applicable to the PRINCIPAL USE.

#### 2. Arts & Creative Enterprise Use Categories

##### a. ARTISINAL PRODUCTION

The on-SITE production of hand-fabricated or hand-manufactured parts and custom or craft CONSUMER GOODS based on the skill and knowledge of the artisan and the USE of hand tools or small-scale, light mechanical equipment. The ARTISINAL PRODUCTION category includes apparel MANUFACTURING, breweries, cabinetry, chocolatiers, confectionery, furniture making, glass working, jewelry making, metal working, pottery, sculpture, wood working, and their substantial equivalents. Showrooms and the ANCILLARY sales of goods produced on-SITE are permitted. The following standards apply:

- i. The production of offensive noise, vibration, smoke, dust or other PARTICULATE matter, heat, humidity, glare, or other objectionable effect is prohibited, except in the Fabrication and Commercial Industry districts.
- ii. In addition to the review criteria for all Special Permits specified in §15.2.1.e. Review Criteria, the review board shall make findings considering the following in its discretion to approve or deny a special permit authorizing an ARTISINAL PRODUCTION PRINCIPAL USE:
  - a). Appreciable methods to mitigate noise for ABUTTING residential properties.
  - b). Location of loading, trash and recycling storage, and the procedure for drop-off and pickup.
  - c). The limitation of visitors and ANCILLARY retail sales to between the hours of 7:00am to 9:00pm.

##### b. ARTS EXHIBITION

The production, rehearsal, or live performance of cultural entertainment or artistic expression such as singing, dancing, comedy, literary readings, performance art, musical theater, live plays, and concerts. The ARTS EXHIBITION category includes venues such as assembly halls, auditoriums, cinemas, concert

halls, dinner theaters, gallery space, performance halls, rehearsal & preproduction studios, live theaters, and their substantial equivalents along with the administrative offices, booking agencies, and ticket sales of performing arts organizations.

##### c. ARTS SALES OR SERVICES

The display and retail sale, lease, or rental of finished artwork, art supplies, musical instruments, multi-media, or publications and activities that provide various arts related services to individuals, groups, or businesses including galleries, supply stores, printing shops, set design studios, and their substantial equivalents. The following standards apply:

- i. OUTDOOR DISPLAY of products and merchandise is permitted according to the following:
  - a). OUTDOOR DISPLAY is permitted in any storefront frontage or on a public sidewalk subject to all City Ordinances as an ANCILLARY activity.
  - b). OUTDOOR DISPLAY must be removed and placed inside a fully-enclosed BUILDING at the end of each business day.
  - c). Display areas extending more than eight feet from the FACADE are prohibited.
  - d). A minimum four (4) foot wide clear path of ACCESS must be maintained to the PRINCIPAL ENTRANCE.
  - e). Display areas are permitted to occupy no more than 30% of the FRONTAGE AREA.
  - f). Display areas must comply with the sidewalk standards of Article 8: PUBLIC REALM.
- ii. In addition to the review criteria for all Special Permits specified in §15.2.1.e. Review Criteria, the review board shall make findings considering the following in its discretion to approve or deny a special permit authorizing an arts sales & service PRINCIPAL USE:
  - a). Appreciable methods to mitigate noise for ABUTTING residential properties.
  - b). Location of loading, trash and recycling storage, and the procedure for drop-off and pickup.
  - c). The limitation of visitors and ANCILLARY retail sales to between the hours of 7:00am to 9:00pm.

##### d. Co-WORKING

A commercial or non-profit organization providing multiple individuals and small firms ACCESS to workplace facilities, including but not limited to, artist studios, office suites, for-rent 'hot-desks', dedicated workstations, conference rooms, meeting rooms, event space, resource libraries, and business or administrative support services.

##### e. Design SERVICES

Individuals and firms that provide design SERVICES

to individuals, groups, or businesses including architectural design, fashion design, graphic design, interior design, industrial design, landscape architecture, product DEVELOPMENT, software DEVELOPMENT, urban design, and their substantial equivalents.

- i. In addition to the review criteria for all Special Permits specified in §15.2.1.e. Review Criteria, the review board shall make findings considering the following in its discretion to approve or deny a special permit authorizing a design SERVICES PRINCIPAL USE:
  - a). Appreciable methods to mitigate noise for ABUTTING residential properties.
  - b). Location of loading, trash and recycling storage, and the procedure for drop-off and pickup.
  - c). The limitation of visitors to between the hours of 7:00am to 9:00pm.
- f. Shared Workspaces or Arts Education  
The transfer of knowledge or skills related to the creative enterprises through teaching, training, or research; organizations providing collaborative workplace facilities and business planning, finance, mentoring, and other business or administrative support services to creative enterprises; and multi-purpose facilities dedicated to providing space for multiple creative enterprises. The shared workspace & arts education category includes arts centers, CREATIVE INCUBATORS, CULINARY INCUBATORS, design & FABRICATION CENTERS, FABRICATION LABORATORIES, and their substantial equivalents.
  - i. In addition to the review criteria for all Special Permits specified in §15.2.1.e. Review Criteria, the review board shall make findings considering the following in its discretion to approve or deny a special permit authorizing a shared workspace & arts education PRINCIPAL USE:
    - a). Appreciable methods to mitigate noise for ABUTTING residential properties.
    - b). Location of loading, trash and recycling storage, and the procedure for drop-off and pickup.
    - c). The limitation of visitors to between the hours of 7:00am to 9:00pm.
- g. Work/Live CREATIVE STUDIO  
CREATIVE STUDIO space consisting of not more than one (1) room, including an area for ACCESSORY living, where the work needs of creative industry activities within the same BUILDING take precedence over any "quiet expectations" of the residents and neighbors residing in work/live CREATIVE STUDIOS within the same BUILDING. The following standards apply:
  - i. Kitchen, dining, and bathroom facilities, excluding

work sinks, must be shared between the tenants of each floor.

- ii. Floor area for ACCESSORY living space is limited to 200 sq. ft. or 30% of the total floor space of a Work/Live Studio, whichever is less.
- iii. The occupant(s) of the Work/Live CREATIVE STUDIO must be a certified Artist with the Somerville Arts Council.
- iv. In addition to the review criteria for all Special Permits specified in §15.2.1.e. Review Criteria, the review board shall make findings considering the following in its discretion to approve or deny a special permit authorizing a work/live CREATIVE STUDIO PRINCIPAL USE:
  - a). Width of doorways and hallways to accommodate the moving of large objects.
  - b). Weight capacity of elevators to accommodate heavy equipment.
  - c). Access to natural light within each studio with a preference towards northern exposure.
  - d). Sound transmission co-efficients to prevent the transmission of sounds from equipment or repetitive tasks.
  - e). Ventilation and air handling techniques to ensure the safety and health of residents, visitors, and neighbors.
  - f). Ceiling heights that allow for the creation of large works and equipment, including machinery and lighting.
  - g). Weight-bearing capacity of the floor.
  - h). Ability to install flooring for specific users such as dancers or performers.

### 3. Auto-Oriented Use Categories

- a. Commercial Vehicle Repair or Maintenance  
Repair, installation, or maintenance of the mechanical components or the bodies of large trucks, mass transit vehicles, large construction equipment, or commercial boats.
  - i. In addition to the review criteria for all Special Permits specified in §15.2.1.e. Review Criteria, the review board shall make findings considering the following in its discretion to approve or deny a special permit authorizing a Vehicle Repair or Maintenance PRINCIPAL USE:
    - a). Location of driveways entrances and ACCESS points in relation to the safety of pedestrians, bicyclists, and motor vehicles.
    - b). Visual impact and quality of screening of vehicles.
- b. DISPATCH SERVICE  
The storage and dispatch of ambulances, taxis, limousines, armored cars, tow trucks, buses, and similar vehicles for specialized transportation, including

# 9. USE PROVISIONS

## Use Definitions & Standards

where ambulance crews not located at a HOSPITAL or fire department stand by for emergency calls, ANCILLARY professional offices, and/or minor vehicle service and maintenance repair. The following specific DISPATCH SERVICE USES are regulated differently than other USES classified within the DISPATCH SERVICE category:

- i. Towing Service
  - Storage of towed vehicles and/or the parking and dispatch of tow vehicles.
  - a). In addition to the review criteria for all Special Permits specified in §15.2.1.e. Review Criteria, the review board shall make findings considering the following in its discretion to approve or deny a special permit authorizing a towing service PRINCIPAL USE:
    - i). Compatibility of the towing service with other surrounding properties.
    - ii). Location of driveways entrances and ACCESS points in relation to the safety of pedestrians, bicyclists, and motor vehicles.
    - iii). Visual impact and quality of screening of vehicles.
    - iv). Sight lines needed by the driver of any vehicle entering or exiting the SITE.
    - v). Procedures for controlling emission of noxious or hazardous materials or substance.
- c. Gasoline Station
  - Uses engaged in the retail sales of personal or commercial vehicle fuels.
- d. Motor Vehicle Parking
  - The storage, for a limited period of time, of operable motor vehicles. The specific USE types within the motor vehicle parking USE category are:
    - i. Off-SITE ACCESSORY Parking
      - Motor vehicle parking that supports a PRINCIPAL USE on a different LOT.
        - a). In addition to the review criteria for all Special Permits specified in §15.2.1.e. Review Criteria, the review board shall make findings considering the following in its discretion to approve or deny a special permit authorizing an off-SITE ACCESSORY parking PRINCIPAL USE:
          - i). Location of driveways entrances and ACCESS points in relation to the safety of pedestrians, bicyclists, and motor vehicles.
          - ii). Visual impact and quality of screening of vehicles.
- e. Personal Vehicle Repair or Maintenance
  - Repair, installation, or maintenance of the mechanical components or the bodies of automobiles, small trucks or vans, motorcycles, motor homes, or recreational vehicles or that wash, clean, or otherwise protect the exterior or interior surfaces of these types of vehicles.
- i. In addition to the review criteria for all Special Permits specified in §15.2.1.e. Review Criteria, the review board shall make findings considering the following in its discretion to approve or deny a special permit authorizing a Vehicle Repair or Maintenance PRINCIPAL USE:
  - a). Location of driveways entrances and ACCESS points in relation to the safety of pedestrians, bicyclists, and motor vehicles.
  - b). Visual impact and quality of screening of vehicles.
- f. Vehicle Sales
  - Sale or rental of new or USED automobiles, small trucks or vans, motorcycles, motor homes, or recreational vehicles. Examples of personal vehicle sales & rental establishments include new and USED automobile dealers, and car rental agencies. The following standards apply:
    - i. On-SITE vehicle maintenance and repair is considered an additional PRINCIPAL USE.
    - ii. Vehicles for display, sale, or lease must be located entirely within a building.
    - iii. In addition to the review criteria for all Special Permits specified in §15.2.1.e. Review Criteria, the review board shall make findings considering the following in its discretion to approve or deny a special permit authorizing a Vehicle Repair or Maintenance PRINCIPAL USE:
      - a). Location of driveways entrances and ACCESS points in relation to the safety of pedestrians, bicyclists, and motor vehicles.
      - b). Visual impact and quality of screening of vehicles.

### 4. Cannabis Establishment Use Categories

- a. The following standards apply to all specific USE types in the Cannabis Establishment USE category:
  - i. Cannabis enterprises must be compliant with M.G.L. 94G and M.G.L. 94I.
  - ii. Cannabis enterprises must be licensed by the Massachusetts Cannabis Control Commission and the Somerville Licensing Commission.
  - iii. Development review applications are not considered complete until a Community Host Agreement is granted by the City of Somerville.
- b. CANNABIS CULTIVATION
  - The cultivation of soil for the production, planting, caring for, treating, growing, and harvesting of cannabis.
- c. CANNABIS PRODUCT MANUFACTURING
  - The processing, assembly, treatment, or packaging of cannabis products.
- d. CANNABIS RETAIL SALES
  - The purchasing or selling cannabis or cannabis

products by and between Cannabis Establishments or the selling or provision otherwise of cannabis or cannabis products to consumers, including medical marijuana facilities. The following standards apply:

- i. Cannabis retail sales USES must be located at least three hundred (300) feet from any pre-primary, primary, or secondary Educational Services uses or any Educational Services Protected by M.G.L. 40A. Sec. 3.
- ii. Cannabis retail sales USES are not permitted to occupy more than ten thousand (10,000) square feet of floor area.
- iii. SIGNAGE for cannabis retail sales USES must comply with 935 CMR 500 and M.G.L. c. 94c, §34.
- iv. In addition to the review criteria for all Special Permits specified in §15.2.1.e. Review Criteria, the review board shall make findings considering the following in its discretion to approve or deny a special permit authorizing a cannabis retail sales principal PRINCIPAL USE:
  - a). Capacity of the local THOROUGHFARE network providing ACCESS to the SITE and impact on pedestrian, bicycle, and vehicular traffic and circulation patterns in the neighborhood.
  - b). Location, visibility, and design of the PRINCIPAL ENTRANCE.
- v. The review boards may not grant a special permit authorizing a cannabis retail sales USE within five-hundred (500) feet of any pre-primary, primary, or secondary Educational Services USES or any Educational Services Protected by M.G.L. 40A. Sec. 3, without finding that the cannabis retail sales USE is not detrimental to the Education Services USE.

**e. Cannabis Research & DEVELOPMENT**

An academic institution, non-profit or domestic corporation, or other entity authorized to conduct business in the Commonwealth of Massachusetts that conducts analyses, testing, and the DEVELOPMENT of marijuana based products.

**f. Cannabis Testing Laboratory**

The controlled scientific analysis, research, experimentation, or measurement of cannabis, cannabinoids, and cannabis products.

**5. Civic & Institutional Use Categories**

**a. COMMUNITY CENTER**

A place for recreational, social, educational or cultural activities operated by a non-profit or public agency.

**b. HOSPITAL**

An institution providing health services to patients and offering inpatient (overnight) medical or surgical care.

- i. In addition to the review criteria for all Special Permits specified in §15.2.1.e. Review Criteria,

the review board shall make findings considering the following in its discretion to approve or deny a special permit authorizing a HOSPITAL PRINCIPAL USE:

- a). Compatibility with the level of activity associated with surrounding properties.
- b). Capacity of the local THOROUGHFARE network providing ACCESS to the SITE and impact on pedestrian, bicycle, and vehicular traffic and circulation patterns in the neighborhood.
- c). Location, visibility, and design of the PRINCIPAL ENTRANCE, emergency room, patient drop-off areas, and outdoor AMENITY SPACE for employees or patients.
- d). Location and adequacy of existing public utilities and proposed changes to the sanitary sewer system, storm drainage system, and public water.

**c. LIBRARY**

A facility providing physical or digital ACCESS to information resources for reference or borrowing by the general public and often providing areas for study, research, and collaboration.

**d. MINOR UTILITY FACILITY**

Public and quasi-public facilities and services that need to be located in the area where the service is to be provided, such as water and sewer pump stations; electrical transforming substations; wind energy conversion systems; solar collector systems; water conveyance systems; gas regulating stations; storm water facilities and conveyance systems; telephone switching equipment; emergency communication warning/broadcast facilities; and central heating facilities.

- i. In addition to the review criteria for all Special Permits specified in §15.2.1.e. Review Criteria, the review board shall make findings considering the following in its discretion to approve or deny a special permit authorizing a minor utility PRINCIPAL USE:

- a). Need for a facility at the proposed SITE taking into consideration the proximity of the area of service of the utility.
- b). Visual impact and quality of screening from ABUTTING THOROUGHFARES and surrounding properties.
- c). Impact and mitigation of offensive noise, vibration, smoke, dust or other PARTICULATE matter, heat, humidity, glare or other objectionable effects.
- d). Location of ACCESS for servicing the facility.

**e. MAJOR UTILITY FACILITY**

INFRASTRUCTURE services that have substantial land use impacts on surrounding areas. Typical uses include but are not limited to water and wastewater treatment



# 9. USE PROVISIONS

## Use Definitions & Standards

facilities, major water storage facilities and electric generation plants.

f. MUSEUM

A repository for a collection or collections of historical, natural, scientific, or literary objects of interest. The following standards apply:

i. ANCILLARY sales and the holding of meetings and social events are permitted.

g. Private Non-Profit Club or Lodge

An organization, which is open to people upon invitation, nomination, or payment of fees or dues for social, recreational, or entertainment activities. The following standards apply:

i. A non-profit club or lodge must be managed by an association with elected officers and directors, pursuant to a charter or bylaws, that generally excludes the general public from its premises, and which holds property for the common benefit of its members.

ii. A non-profit club or lodge may serve meals or alcohol on the premises for members and their guests.

iii. A non-profit club or lodge must be open only to members and their occasional guests.

iv. A non-profit club or lodge may USE one central gathering area for rental for events or community activities, including the service of meals or alcohol, but such rentals and activities may not exceed eighty (80) events per year and may not continue past 1:00 AM Friday, Saturday, and Sunday nights and 12:00 AM Monday through Thursday nights.

v. In addition to the review criteria for all Special Permits specified in §15.2.1.e. Review Criteria, the review board shall make findings considering the following in its discretion to approve or deny a special permit authorizing a private, non-profit club or lodge PRINCIPAL USE:

a). Compatibility with the level of activity associated with the surrounding properties.

b). Location of ACCESS to the SITE and BUILDING.

c). Impact and mitigation of the production of offensive noise and light.

d). Location of trash and recycling storage and the procedure for pickup.

h. Public Service

Essential government services provided to the community at large including municipal operations of the City of Somerville, such as departmental offices, social service facilities, and public works facilities; public safety services, such as police and firefighting headquarters and substations; and OPEN SPACES reserved for social and recreational activities or natural resource protection.

i. Religious & Educational Services Protected by M.G.L.

40A. Sec. 3

Activities related to providing general or specialized education, instruction, or training in subject areas, skills, or vocations and the practice of religions, including all ACCESSORY and ANCILLARY activities customarily included in the operations of educational institutions and religious organizations. The following standards apply:

i. Real property must be owned or leased by the Commonwealth of Massachusetts, a religious sect or denomination, or by a non-profit educational corporation.

## 6. Commercial Services Use Categories

a. ANIMAL SERVICES

Any of the following: (1) grooming of dogs, cats, and similar small animals, including dog bathing and clipping salons and pet grooming shops; (2) animal shelters, care services, and kennel services for dogs, cats and small animals, including boarding kennels, pet resorts/hotels, dog training centers, and animal rescue shelters excluding those operated by the City of Somerville; (3) animal HOSPITALS or veterinary services; (4) household pet crematory services; or (5) taxidermy services.

i. Commercial Kennel: animal rescue shelters, boarding facilities, pet resorts or hotels, or training services for dogs, cats, and other household pets.

a). In addition to the review criteria for all Special Permits specified in §15.2.1.e. Review Criteria, the review board shall make findings considering the following in its discretion to approve or deny a special permit authorizing a commercial kennel PRINCIPAL USE:

i). Methods or techniques for noise mitigation to limit noise for other users of the building and ABUTTING properties.

ii). Operational procedures for cleaning the interior and exterior of the SITE and trash storage and removal.

iii). Amount of on-SITE landscaping.

ii. Pet Grooming: The grooming of dogs, cats, and similar household pets.

iii. Pet Day Care or Training: kennel and/or training centers for animals operated on a daytime-only basis.

a). In addition to the review criteria for all Special Permits specified in §15.2.1.e. Review Criteria, the review board shall make findings considering the following in its discretion to approve or deny a special permit authorizing a pet day care or training PRINCIPAL USE:

i). Methods or techniques for noise mitigation to limit noise for other users of the building



## 9. USE PROVISIONS

### Use Definitions & Standards

- and ABUTTING properties.
      - ii). Operational procedures for cleaning the interior and exterior of the SITE and trash storage and removal.
      - iii). Amount of on-SITE landscaping.
    - iv. Veterinarian: the diagnosis and treatment of animal patients' illnesses, injuries, and physical malfunctions performed in an office setting. The following standards apply:
      - a). Overnight boarding of animals is limited to patients recovering from medical procedures.
      - b). In addition to the review criteria for all Special Permits specified in §15.2.1.e. Review Criteria, the review board shall make findings considering the following in its discretion to approve or deny a special permit authorizing a veterinarian PRINCIPAL USE:
        - i). Methods or techniques for noise mitigation to limit noise for other USERS of the BUILDING and ABUTTING properties
        - ii). Operational procedures for cleaning the interior and exterior of the SITE and trash storage and removal.
        - iii). Amount of on-SITE landscaping.
  - b. ASSEMBLY OR ENTERTAINMENT  
USES that provide gathering places for participant or spectator recreation, entertainment, or other assembly activities including, but not limited to, a theater, cinema, and/or venue of a professional or semi-professional sports team. The following standards apply:
    - i. Assembly and entertainment USES may provide incidental food or beverage service for on-SITE consumption.
    - ii. In addition to the review criteria for all Special Permits specified in §15.2.1.e. Review Criteria, the review board shall make findings considering the following in its discretion to approve or deny a special permit authorizing an ASSEMBLY OR ENTERTAINMENT PRINCIPAL USE:
      - a). Compatibility with the level of activity associated with the surrounding properties.
      - b). Location of designated outdoor smoking areas.
  - c. BANKING OR FINANCIAL SERVICES  
USES related to the exchange, lending, borrowing, and safe-keeping of money. The following banking & financial service specific USE types are regulated differently than other USES classified within the banking & financial services category:
    - i. Personal Credit: Banking USES providing short-term loans and check cashing services without providing traditional banking accounts.
      - a). In addition to the review criteria for all Special Permits specified in §15.2.1.e. Review
- Criteria, the review board shall make findings considering the following in its discretion to approve or deny a special permit authorizing a personal credit PRINCIPAL USE:
- i). The demonstrated need for this service by unbanked or underbanked members of the community.
  - ii). Cost savings, transparency of services, and customer service offered compared to traditional banking & financial service USES.
- d. BROADCAST OR RECORDING STUDIO  
USES that provide studios for audio or video production, recording, filming, or broadcasting of radio or television programs over-the-air, cable, or satellite. Telecommunications transmission TOWERS are regulated according to the provisions of §6.C. Wireless Communication STRUCTURES
  - e. BUILDING OR HOME REPAIR SERVICES  
USES that provide maintenance and repair services for all structural and mechanical elements of STRUCTURES, as well as the exterior spaces of a premise. Typical USES include janitorial, landscape maintenance, exterminator, plumbing, electrical, HVAC, window cleaning, and similar services.
    - i. In addition to the review criteria for all Special Permits specified in §15.2.1.e. Review Criteria, the review board shall make findings considering the following in its discretion to approve or deny a special permit authorizing a BUILDING & home repair services PRINCIPAL USE:
      - a). Visual impact and quality of screening of parked business vehicles.
  - f. BUSINESS SUPPORT SERVICES  
USES that provide personnel services, printing, copying, photographic services, or communication services to businesses or consumers. Typical USES include employment agencies, copy and print shops, telephone answering services, and photo developing labs.
  - g. CATERER OR WHOLESALE FOOD PRODUCTION  
The preparation of food in significant quantities to be delivered and served or sold off-SITE.
    - i. In addition to the review criteria for all Special Permits specified in §15.2.1.e. Review Criteria, the review board shall make findings considering the following in its discretion to approve or deny a special permit authorizing a caterer/wholesale food production PRINCIPAL USE:
      - a). Location of driveway entrances and ACCESS points in relation to the safety of pedestrians, bicyclists, and motor vehicles.
      - b). Visual impact and quality of screening of parked business vehicles.
      - c). Location of loading, trash and recycling storage and the procedure for pickup and drop-off.

# 9. USE PROVISIONS

## Use Definitions & Standards

- d). Ventilation and air handling techniques to reduce the emission of odor or exhaust onto neighboring properties.
- h. DAY CARE SERVICES  
USES that provide licensed care, protection, and supervision in a protective setting for children or adults, with or without compensation, on a regular basis away from their primary residence and for less than sixteen (16) hours per day. The specific USE types within the day care service USE category are:
  - i. ADULT DAY CARE CENTER: A day care service USE providing custodial care of adults over eighteen (18) years old, related or unrelated, who are in need of supervision and/or assistance with routine daily functions but who are not in need of regular medical attention. The following standards apply:
    - a). All persons must be eighteen (18) years of age or older.
  - ii. CHILD Day Care Center: A day care service as defined in MGL 15D Section 1A.
- i. Educational Services  
The general or specialized pre-primary, primary, secondary, vocational, or tertiary education, instruction, or training in subject areas, skills, or vocations. Facilities customarily provided by educational service USES in directly serving the needs of employees and students are permitted including, but not limited to, classrooms, administrative offices, research centers, laboratories, auditoria, study halls, on-campus housing, libraries, temporary structures, campus centers, bookstores, laundry services, light manufacturing, retail sales, Food & Beverage Services, banks, athletic fields, parking facilities, and their substantial equivalents.
- j. Maintenance or Repair Services  
USES that provide maintenance, cleaning, or repair services for consumer goods. Typical USES include dry cleaning shops, tailors, shoe repair, vacuum repair shops, electronics repair shops, and similar establishments.
- k. Personal Services  
USES that provide a variety of services associated with personal grooming, personal instruction, and the maintenance of fitness, health, and well-being. The following PERSONAL SERVICES specific USE types are regulated differently than other USES classified within the PERSONAL SERVICES USE category:
  - i. BODY ART SERVICES  
USE of a space for the practice of physical body adornment by permitted establishments and practitioners using, but not limited to the following techniques: PIERCING, tattooing, cosmetic tattooing, branding and scarification. The following performance standards apply:
    - a). Procedures considered ‘medical procedures’ by the Board of Registration in medicine, such as implants under the skin, are prohibited in Body-Art Servicess.
  - b). No Body Art establishment may be located within 500 feet of an establishment selling items primarily involving ‘sexual content’ as defined by MGL 232 Section 31.
  - c). In addition to the review criteria for all Special Permits specified in §15.2.1.e. Review Criteria, the review board shall make findings considering the following in its discretion to approve or deny a special permit authorizing a body art PRINCIPAL USE:
    - i). Design of storefront windows and operations plans for ensuring the privacy of patrons.
    - d). The review boards may not grant a special permit authorizing a body art services PRINCIPAL USE within five-hundred (500) feet of any other body art services PRINCIPAL USE.
- ii. Fitness Services  
USE of space for physical exercise or training on an individual or group basis, using exercise equipment or open floor space, with or without an option for having instruction with a personal trainer.
- iii. Funeral Services  
A facility where the deceased are prepared for burial display and for rituals before burial or cremation. Such facilities may include chapels, crematoriums, and showrooms for the display and sale of caskets, vaults, urns, and other items related to burial services.
  - a). In addition to the review criteria for all Special Permits specified in §15.2.1.e. Review Criteria, the review board shall make findings considering the following in its discretion to approve or deny a special permit authorizing a Funeral Services PRINCIPAL USE:
    - i). Capacity of the local THOROUGHFARE network providing ACCESS to the SITE and impact on pedestrian, bicycle, and vehicular traffic and circulation patterns in the neighborhood.
    - ii). Location, visibility, and design of the PRINCIPAL ENTRANCE.
- iv. Health Care Services  
An office providing outpatient health services involving the diagnosis and treatment of physical or mental ailments and disorders, including doctors, dentists, mental health practitioners, physical therapists, and their substantial equivalents.
  - a). In addition to the review criteria for all Special Permits specified in §15.2.1.e. Review Criteria, the review board shall make findings

considering the following in its discretion to approve or deny a special permit authorizing a Health Care Services PRINCIPAL USE:

- i). Compatibility with the level of activity associated with surrounding properties
- ii). Location, visibility, and design of the PRINCIPAL ENTRANCE, patient drop-off areas, and outdoor AMENITY SPACE for employees or patients.

v. Formula Personal Services

Any USE classified under the personal services USE category which, along with nine (9) or more other businesses regardless of ownership or location worldwide, does or is required as a franchise to maintain two (2) or more of the following features: a standardized array of merchandise, a standardized FACADE, a standardized decor and color scheme, a standardized employee uniform, a standardized SIGN or SIGNAGE, or a trademark service mark.

a). In addition to the review criteria for all Special Permits specified in §15.2.1.e. Review Criteria, the review board shall make findings considering the following in its discretion to approve or deny a special permit authorizing a formula retail PRINCIPAL USE:

- i). The existing concentrations of formula personal service USES within the neighborhood;
- ii). The availability of other similar personal service USES and the maintenance of a diverse blend of retail USES within the neighborhood;
- iii). The compatibility of the proposed formula personal service USE with the existing architectural and aesthetic character of the neighborhood;
- iv). The proposed USES contribution to the nationwide trend of standardized retail offerings that detracts from the uniqueness of Somerville’s neighborhoods; and
- v). The existing non-residential vacancy rates within the neighborhood.

I. Recreation Services

Use of indoor or outdoor space for the communal or solitary, active or passive pursuit of leisure activities. The following standards apply:

- i. All outdoor lighting must be turned off when outdoor facilities are not in USE, or by 10:00 p.m. on Sundays through Thursdays, and by 11 p.m. on Fridays and Saturdays, whichever is earlier.
- ii. In addition to the review criteria for all Special Permits specified in §15.2.1.e. Review Criteria, the review board shall make findings considering

the following in its discretion to approve or deny a special permit authorizing a Recreation Services PRINCIPAL USE:

- i). Compatibility with the level of activity associated with the surrounding properties.
- ii). Capacity of the local THOROUGHFARE network providing ACCESS to the SITE and impact on pedestrian, bicycle, and vehicular traffic and circulation patterns in the neighborhood.
- iii). Location and visibility of the PRINCIPAL ENTRANCE and pedestrian circulation from all exit points.

m. Vehicle Parking

The rent or lease of parking spaces for motor vehicles, the USE of a RESERVED PARKING space for a fleet vehicle of a car sharing service, and the USE of land for the docking station of a bicycle-sharing service. The specific USE types within the vehicle parking USE category are:

i. BIKE-SHARE PARKING

Parking for bicycles that are made available for an hourly rental fee as part of a business operating ten (10) or more docking stations within the City of Somerville or surrounding municipalities. The following standards apply:

- a). Docking stations must not interfere with the reasonable visibility needs of drivers, the flow of pedestrians traffic, or needs of businesses on the same SITE.

ii. CAR-SHARE PARKING

Parking for motor vehicles that are made available for hourly or daily rental fee to members of a car sharing service.

a). In addition to the review criteria for all Special Permits specified in §15.2.1.e. Review Criteria, the review board shall make findings considering the following in its discretion to approve or deny a special permit authorizing a CAR-SHARE PARKING PRINCIPAL USE:

- i). Compliance with any minimum parking requirement of this Ordinance.
- ii). Privacy of on-SITE OR ABUTTING residential USES from the route of pedestrian ACCESS to the CAR-SHARE PARKING space.

iii. COMMERCIAL PARKING

Parking spaces for motor vehicles that are rented or leased through various offerings including, but not limited to, monthly passes, overnight passes, daily rates (weekday and weekend), or hourly fees to residents, employees, and the public, twenty-four (24) hours per day, seven (7) days per week, three-hundred and sixty-five (365) days per year.

# 9. USE PROVISIONS

## Use Definitions & Standards

The following standards apply:

- a). Reserved spaces must be subject to a price premium that reflects the under-utilization of that space as a shared resource that is no less than two hundred percent (200%) of the demonstrated market rate for a parking space reserved for a similar time period within a reasonable market radius.
- b). The review boards shall require the operator of any permitted Commercial Parking USE to submit an annual report to validate continued compliance with the provisions of this Ordinance in accordance with the standards for monitoring and annual reporting of the Director of Mobility.

### 7. Food & Beverage Service Use Categories

#### a. BAR, RESTAURANT, OR TAVERN

An establishment, with or without live entertainment, preparing and selling ready-to-consume food or drinks and the sale of alcoholic beverages for on-site consumption. The Bar, Restaurant, or Tavern USE category includes lounges, nightclubs, dance halls, pubs, saloons and their substantial equivalents. The following standards apply:

- i. A license from the City Council
- ii. is required to serve alcoholic beverages.
- iii. Outdoor seating is permitted on the LOT or on a public sidewalk subject to all City Ordinances as an ANCILLARY activity. See §10.5 OUTDOOR CAFE SEATING for more information.

#### b. Bakery, Cafe, or Coffee Shop

An establishment preparing and selling ready-to-consume food and drinks. The following standards apply:

- i. Outdoor seating is permitted on the LOT or on a public sidewalk subject to all City Ordinances as an ANCILLARY activity. See §10.5 OUTDOOR CAFE SEATING for more information.

#### c. Formula Food or Beverage Service

Any USE classified under the Food & Beverage Service USE category which, along with nine (9) or more other businesses regardless of ownership or location worldwide, does or is required as a franchise to maintain two (2) or more of the following features: a standardized menu, a standardized FACADE, a standardized decor or color scheme, a standardized uniform, a standardized SIGN or SIGNAGE, a trademark or a service mark. The following standards apply:

- i. Outdoor seating is permitted on the LOT or on a public sidewalk subject to all City Ordinances as an ANCILLARY activity. See §10.5 OUTDOOR CAFE SEATING for more information.
- ii. In addition to the review criteria for all Special

Permits specified in §15.2.1.e. Review Criteria, the review board shall make findings considering the following in its discretion to approve or deny a special permit authorizing a formula food & beverage service PRINCIPAL USE:

- a). The existing concentrations of formula Food & Beverage Service principal USES within the neighborhood;
- b). the availability of other similar Food & Beverage Service USES and the maintenance of a diverse blend of Food & Beverage Service USES within the neighborhood;
- c). the compatibility of the proposed design for the formula Food & Beverage Service with the existing architectural and aesthetic character of the neighborhood;
- d). the proposed USES contribution to the nationwide trend of standardized Food & Beverage Service offerings that detracts from the uniqueness of Somerville's neighborhoods; and
- e). the existing non-residential vacancy rates within the neighborhood.

### 8. Industrial Use Categories

#### a. DRY CLEANING OR LAUNDRY SERVICES

USES that provide centralized dry cleaning and/or laundry services for other industrial, commercial, and/or business establishments.

- i. In addition to the review criteria for all Special Permits specified in §15.2.1.e. Review Criteria, the review board shall make findings considering the following in its discretion to approve or deny a special permit authorizing a commercial dry cleaning or laundry services PRINCIPAL USE:
  - a). Location of driveway entrances and ACCESS points in relation to the safety of pedestrians, bicyclists, and motor vehicles.

#### b. DATA CENTER

USES providing information storage and processing services to other businesses or end users through a collection of computer servers and related information technology INFRASTRUCTURE.

- i. In addition to the review criteria for all Special Permits specified in §15.2.1.e. Review Criteria, the review board shall make findings considering the following in its discretion to approve or deny a special permit authorizing a DATA CENTER PRINCIPAL USE:
  - a). Mitigation of any negative aesthetic impacts that might result from required security measures and restrictions on visibility into the BUILDING's interior.
  - b). Ability for the USE to adequately contribute towards increasing employment opportunities

- in the city.
- c. **MANUFACTURING**  
The processing, assembly, treatment, or packaging of mass produced finished parts or products primarily through automation, mechanization, or assembly line processes. Typical USES include electronics and electrical equipment assembly, food and beverage processing and packaging, and the production of parts and sub-assemblies for other products. The following standards apply to all specific USE types in the manufacturing USE category:
  - i. Operations may include the storage of materials and the loading and unloading of new materials and finished products.
  - ii. Showrooms and the ANCILLARY sales of goods produced on-SITE are prohibited.
  - iii. The production or USE of large quantities of hazardous or explosive materials is prohibited.
- d. **Moving or Storage Services**  
USES engaged in the moving of household or office furniture, appliances, and equipment from one location to another, including the temporary storage of those same items. Typical USES include moving companies and self-service and mini-storage warehouses. The following moving & self storage specific USE types are regulated differently than other USES classified within the moving & self storage category:
  - i. **Self Storage:** The temporary storage of personal possessions in containers or individual rentable or leaseable spaces. The following standards apply:
    - a). A self storage USE is only permitted in a BUILDING with more than one (1) PRINCIPAL USE, excluding another self storage USE.
    - b). In addition to the review criteria for all Special Permits specified in §15.2.1.e. Review Criteria, the review board shall make findings considering the following in its discretion to approve or deny a special permit authorizing a self storage PRINCIPAL USE:
      - i). Mitigation of any negative aesthetic impacts that might result from required security measures and restrictions on visibility into the BUILDING's interior.
      - ii). Location of loading, trash, and recycling storage, and the procedure for drop-off and pickup.
      - iii). Ability for the USE to adequately contribute towards SomerVision's objectives for increasing employment opportunities in the city.
      - iv). Abnormal SITE conditions that make the less than desirable for other USES.
- e. **Recycling Collection**  
USES that collect and temporarily store recyclable household materials including glass, cardboard, paper, aluminum, tin, and plastics that are regularly moved off-SITE to be processed elsewhere.
  - i. In addition to the review criteria for all Special Permits specified in §15.2.1.e. Review Criteria, the review board shall make findings considering the following in its discretion to approve or deny a special permit authorizing a recycling collection PRINCIPAL USE:
    - a). Compatibility with the level of activity associated with the surrounding properties.
    - b). Capacity of the local THOROUGHFARE network providing ACCESS to the SITE.
    - c). Location and screening of loading, the procedure for drop-off and pickup, and the impact on pedestrian, bicycle, and vehicular traffic and circulation patterns in the neighborhood.
    - d). Visual impact and quality of screening of parked business vehicles.
- f. **Salvage Yard**  
An area or BUILDING where JUNK, waste, or scrap materials are bought, sold, exchanged, stored, baled, packed, disassembled, or handled for reclamation, disposal, or other like purposes, including but not limited to, scrap iron and other metals, paper, rags, rubber tires, and bottles. A salvage yard includes an auto wrecking yard or BUILDING.
- g. **Trucking or Transportation Depot**  
USES engaged in the dispatching and long-term or short-term storage of large vehicles. Minor repair and maintenance of vehicles stored on the premises is also included.
  - i. In addition to the review criteria for all Special Permits specified in §15.2.1.e. Review Criteria, the review board shall make findings considering the following in its discretion to approve or deny a special permit authorizing a trucking & transportation depot PRINCIPAL USE:
    - a). Compatibility with the level of activity associated with the surrounding properties.
    - b). Capacity of the local THOROUGHFARE network providing ACCESS to the SITE and impact on pedestrian, bicycle, and vehicular traffic and circulation patterns in the neighborhood.
    - c). Location of driveway entrances and ACCESS points in relation to the safety of pedestrians, bicyclists, and motor vehicles.
    - d). Sight lines needed by the driver of any vehicle entering or exiting the SITE.
    - e). Visual impact and quality of screening of parked business vehicles.
    - f). Ventilation and air handling techniques to reduce the emission of odor or exhaust onto



# 9. USE PROVISIONS

## Use Definitions & Standards

- neighboring properties.
- h. Wholesale Trade or Distribution  
Uses engaged in the wholesale collection, sorting, processing, and distribution of bulk mail, packages or commercial goods, storage, processing, and distribution of bulk goods including, but not limited to, furniture & home furnishings; professional and commercial equipment; electrical goods; hardware, plumbing, and heating equipment; paper and paper products; sundries; apparel; food and beverages; healthcare equipment and supplies; and their substantial equivalents to retailers, commercial services, and/or industrial businesses. The following standards apply:
    - i. ANCILLARY retail sales and wholesale showrooms are permitted.
    - ii. Activities may include physically assembling, sorting, and grading goods into large LOTS and breaking bulk for redistribution in smaller LOTS in such a way that has minimal impact on surrounding properties.
    - iii. The wholesale and/or storage or warehousing of toxic and/or hazardous materials is prohibited.

### 9. Lodging Use Categories

- a. BED & BREAKFAST  
A single DWELLING UNIT residential STRUCTURE providing rooms for temporary, overnight lodging, with or without meals, for paying guests. The following standards apply:
  - i. A BED & BREAKFAST lodging USE is only permitted in an owner-occupied or manager-occupied historic STRUCTURE located within a designated LOCAL HISTORIC DISTRICT.
  - ii. A BED & BREAKFAST lodging USE may be located within a PRINCIPAL BUILDING OR AN ACCESSORY STRUCTURE.
  - iii. A common gathering space, such as a parlor, dining room, or living room must be maintained for guest USE.
  - iv. Cooking facilities are not permitted in guest rooms.
  - v. In addition to the review criteria for all Special Permits specified in §15.2.1.e. Review Criteria, the review board shall make findings considering the following in its discretion to approve or deny a special permit authorizing a BED & BREAKFAST PRINCIPAL USE:
    - a). MOBILITY MANAGEMENT options provided to guests and the on-SITE management of parking.
    - b). Compliance with the Somerville Historic Preservation Commission's requirements and guidelines for any alterations to the STRUCTURE OR SITE.
    - c). Operational procedures for limiting noise impacts on neighboring properties.

- b. HOTEL OR HOSTEL  
A BUILDING providing temporary lodging in guest rooms or apartments to persons who have residences elsewhere for a fee. The following standards apply:
  - i. HOTEL OR HOSTEL employees must be on-SITE at all times.
  - ii. A hostel must be associated with a national or international hostel organization.
  - iii. In addition to the review criteria for all Special Permits specified in §15.2.1.e. Review Criteria, the review board shall make findings considering the following in its discretion to approve or deny a special permit authorizing a HOTEL OR HOSTEL PRINCIPAL USE:
    - a). Compatibility with the level of activity associated with the surrounding properties.
    - b). Capacity of the local THOROUGHFARE network providing ACCESS to the SITE and impact on pedestrian, bicycle, and vehicular traffic and circulation patterns in the neighborhood.
    - c). Location and visibility of the PRINCIPAL ENTRANCE, guest drop-off area, taxi queuing station, outdoor AMENITY SPACE for guests or employees, and pedestrian circulation from all exit points.

### 10. Office Use Categories

- a. GENERAL OFFICE  
The regular processing, manipulation, or application of business information or professional expertise predominantly for administrative, professional, and clerical operations in accounting, advertising, business to business brokerage and other BUSINESS SUPPORT SERVICES, employment, finance, healthcare administration, information technology and/or services, insurance, internet content DEVELOPMENT and publishing, law, real estate, urban DEVELOPMENT and their substantial equivalents. Office activities may or may not provide direct services to the public. The following standards apply:
  - i. Office USES do not include activities materially involved in fabricating, assembling, or warehousing physical products for the retail or wholesale market.
- b. Research & DEVELOPMENT or Laboratory  
The analysis, testing, and DEVELOPMENT of products, or services predominantly for scientific research operations in biotechnology, pharmaceuticals, medical equipment, communication & information technology, electronics, computer hardware, and their substantial equivalents. The following standard apply:
  - i. Research & DEVELOPMENT and/or Laboratory does not include activities involved in fabricating, assembling, warehousing, or sale of products for the retail or wholesale market.



- ii. ANCILLARY DEVELOPMENT of mock-up and prototype products is permitted so long as the total floor area devoted to their fabrication or assembly is limited to twenty-five percent (25%) to the GROSS FLOOR AREA occupied by the USE.

**11. Residential Use Categories**

a. HOUSEHOLD LIVING

Residential occupancy of a BUILDING or portion of a BUILDING in DWELLING UNITS by any number of persons related by blood, marriage, adoption, or foster care agreement and up to three (3) additional unrelated persons living together as a single housekeeping unit. Rental of a DWELLING UNIT for less than one (1) month requires compliance with all City Ordinances.

- i. In addition to the review criteria for all Special Permits specified in §15.2.1.e. Review Criteria, the review board shall make findings considering the following in its discretion to approve or deny a special permit authorizing a Household Living PRINCIPAL USE:
  - a). The suitability of the site for a household living principal use compared to other potential principal uses.
  - b). The ability of the development proposal to meet the demand for DWELLING UNITS of various types, sizes, and BEDROOM counts.
  - c). The increase or decrease in the number or price of any previously existing ADUs.

b. GROUP LIVING

Residential occupancy of a BUILDING or portion of a BUILDING in ROOMING UNITS by up to two (2) persons related by blood, marriage, adoption, or foster care agreement; in DWELLING UNITS by more than four (4) unrelated persons; and any multi-unit housing owned by or affiliated with an educational institution. GROUP LIVING residential USES are not permitted to be offered as Short-Term Rentals. The GROUP LIVING USE category includes any residential occupancy that is not categorized as HOUSEHOLD LIVING and any residential accommodations that provide a kitchen, dining room, living room, or bathroom shared between ROOMING UNITS.

- i. In addition to the review criteria for all Special Permits specified in §15.2.1.e. Review Criteria, the review board shall make findings considering the following in its discretion to approve or deny a special permit authorizing a Group Living PRINCIPAL USE:
  - a). The suitability of the site for a group living principal use compared to other potential principal uses.
  - b). The increase or decrease in the number or price of any previously existing ADUs.

- c). Mitigation proposed to alleviate any impacts attributable to the proposed development.

The following GROUP LIVING specific USE types are regulated differently than other USES classified within the GROUP LIVING category:

ii. COMMUNITY OR GROUP RESIDENCE

Residential occupancy of a DWELLING UNIT by more than four (4) unrelated individuals that are 'handicapped' as defined in 42 U.S.C. §3602 or have a 'disability' as defined in 42 U.S.C. §12102. Both terms are defined as a physical or mental impairment that substantially limits one or more major life activities; a record of such an impairment; or being regarded as having such an impairment not including current, illegal USE of or addiction to a controlled substance.

iii. DORMITORY OR CHAPTER HOUSE

Residential occupancy of a BUILDING or portion of a BUILDING in DWELLING UNITS OR ROOMING UNITS exclusively by full- or part-time students, faculty, and staff of an educational institution and any housing owned by or affiliated with an educational institution.

- a). In addition to the review criteria for all Special Permits specified in §15.2.1.e. Review Criteria, the review board shall make findings considering the following in its discretion to approve or deny a special permit authorizing a DORMITORY OR CHAPTER HOUSE PRINCIPAL USE:
  - i). Proximity of the primary educational institution to the SITE.
  - ii). Concentration of dormitories, fraternities, or sororities in the neighborhood.

iv. HOMELESS SHELTER

A facility that has a primary function of providing overnight sleeping accommodations in ROOMING UNITS or bunk rooms to homeless people.

- a). In addition to the review criteria for all Special Permits specified in §15.2.1.e. Review Criteria, the review board shall make findings considering the following in its discretion to approve or deny a special permit authorizing a HOMELESS SHELTER:
  - i). The current supply of overnight sleeping accommodations available within the city.
  - ii). The need for additional resources to properly address changes in demand.

v. NURSING HOME OR ASSISTED LIVING

Residential occupancy in ROOMING UNITS where room and board, PERSONAL SERVICES, and skilled nursing care is provided to tenants. Nursing homes include hospice care, but specifically exclude HOSPITALS.

- a). In addition to the review criteria for all Special Permits specified in §15.2.1.e. Review Criteria, the review board shall make findings

# 9. USE PROVISIONS

## Use Definitions & Standards

considering the following in its discretion to approve or deny a special permit authorizing a nursing home/assisted living PRINCIPAL USE:

- i). Characteristics of the local THOROUGHFARE network in providing a walkable environment and ACCESS for emergency vehicles.
  - ii). Location, visibility, and design of the PRINCIPAL ENTRANCE, resident drop-off area, and outdoor AMENITY SPACES.
  - iii). Provision of communal indoor seating areas with a direct line of SITE to the outdoors.
- vi. Rooming House  
Residential occupancy of four (4) or more ROOMING UNITS by individuals or up to two (2) persons related by blood, marriage, adoption, or foster care agreement. Rooming houses include boarding houses, lodging houses, and single room occupancy (SRO) buildings. The following standards apply:
- a). A license from the City Council is required.
  - b). The unit must be provided with the following:
    - i). HOUSE rules establishing quiet hours, the maximum number of guests, and clean-up requirements for guest pets, if allowed.
    - ii). A functioning fire extinguisher.
    - iii). Child-proofed electrical outlets.
    - iv). A map identifying fire escape routes.
    - v). Directions for operating the temperature control system.
    - vi). Emergency contact information.
  - c). In addition to the review criteria for all Special Permits specified in §15.2.1.e. Review Criteria, the review board shall make findings considering the following in its discretion to approve or deny a special permit authorizing a rooming home PRINCIPAL USE:
    - i). Path of ACCESS to the unit and the privacy of residents and neighboring properties.
    - ii). Location of designated outdoor smoking areas.
    - iii). Operations plan for maintaining the unit, including the inspection schedule for smoke and carbon monoxide detectors and the hours of operation for cleaning services.
- i. OUTDOOR DISPLAY of products and merchandise is permitted according to the following:
- a). OUTDOOR DISPLAY is permitted in the FRONTAGE AREA or on a public sidewalk subject to all City Ordinances as an ANCILLARY activity.
  - b). OUTDOOR DISPLAY must be removed and placed inside a fully-enclosed building at the end of each business day.
  - c). Display areas extending more than eight feet from the FACADE are prohibited.
  - d). A minimum four (4) foot wide clear path of ACCESS must be maintained to the PRINCIPAL ENTRANCE.
  - e). Display areas are permitted to occupy no more than 30% of the FRONTAGE AREA.
  - f). Display areas must comply with the sidewalk standards of Article 8 PUBLIC REALM Standards.
- ii. In addition to the review criteria for all Special Permits specified in §15.2.1.e. Review Criteria, the review board shall make findings considering the following in its discretion to approve or deny a special permit authorizing a building/home supplies & equipment retail PRINCIPAL USE:
- a). Location of driveways entrances and ACCESS points in relation to the safety of pedestrians, bicyclists, and motor vehicles.
  - b). Capacity of the local THOROUGHFARE network providing ACCESS to the SITE and impact on pedestrian, bicycle, and vehicular traffic and circulation patterns in the neighborhood.
  - c). Location of loading, trash and recycling storage, and the procedure for drop-off and pickup.
- b. Consumer Goods  
Selling or otherwise providing consumer goods, functional or decorative, for USE in entertainment, comfort, or aesthetics which are of a size that a customer can typically carry by hand. Consumer goods stores include, but are not limited to, stores selling apparel and ACCESSORIES, sundries, pharmaceuticals, hardware and hand tools, housekeeping supplies, plants and other gardening products, convenience food and beverage for off-SITE consumption, and their substantial equivalents. The manufacturing, assembly, or packaging of merchandise is prohibited unless ANCILLARY to the sale of products from the same location. The following standards apply:
- i. OUTDOOR DISPLAY of products and merchandise is permitted according to the following:
    - a). OUTDOOR DISPLAY is permitted in any storefront frontage or on a public sidewalk subject to all City Ordinances as an ANCILLARY activity.
    - b). OUTDOOR DISPLAY must be removed and placed inside a fully-enclosed building at the end of

## 12. Retail Sales Use Categories

- a. Building/Home Supplies or Equipment  
Uses that sell or otherwise provide furniture, appliances, equipment, and/or home improvement goods needed to repair, maintain, or visually enhance a structure or premises that are, typically, too large to be carried by hand. The following standards apply:

each business day.

- c). Display areas extending more than eight feet from the FACADE are prohibited.
- d). A minimum four (4) foot wide clear path of ACCESS must be maintained to the principal entrance.
- e). Display areas are permitted to occupy no more than 30% of the FRONTAGE AREA.
- f). Display areas must comply with the sidewalk standards of Article 8 PUBLIC REALM Standards.

The following consumer goods specific USE types are regulated differently than other USES classified within the consumer goods category:

ii. Alcohol Sales: Any alcoholic beverage sales establishment primarily involving the sale of alcohol where beer, wine or distilled spirits are sold for off-sale consumption and where more than five (5) percent of the floor area of the establishment is devoted to the sale, display or storage of beer, wine or distilled spirits.

a). In addition to the review criteria for all Special Permits specified in §15.2.1.e. Review Criteria, the review board shall make findings considering the following in its discretion to approve or deny a special permit authorizing a packaged liquor PRINCIPAL USE:

i). Concentration of packaged liquor USES in the neighborhood.

iii. Firearms Sales: A store selling, transferring, or leasing; or advertising for sale, transfer, or lease, or offering or exposing for sale, transfer, or lease, any firearm and/or ammunition.

iv. Pet Store: USES that sell or otherwise provide household pets. The following standards apply:

a). The ANCILLARY sale of pet supplies is permitted.

b). In addition to the review criteria for all Special Permits specified in §15.2.1.e. Review Criteria, the review board shall make findings considering the following in its discretion to approve or deny a special permit authorizing a pet store PRINCIPAL USE:

i). Building methods or techniques for noise mitigation to limit noise for other USERS of the building and ABUTTERS.

c. Formula Retail Sales

Any USE classified under the retail sales USE category which, along with nine (9) or more other businesses regardless of ownership or location worldwide, does or is required as a franchise to maintain two (2) or more of the following features: a standardized array of merchandise, a standardized FACADE, a standardized decor and color scheme, a standardized employee uniform, a standardized SIGN or SIGNAGE, or a trademark service mark.

- i. In addition to the review criteria for all Special Permits specified in §15.2.1.e. Review Criteria, the review board shall make findings considering the following in its discretion to approve or deny a special permit authorizing a formula retail PRINCIPAL USE:
  - a). The existing concentrations of formula retail USES within the neighborhood;
  - b). The availability of other similar retail USES and the maintenance of a diverse blend of retail USES within the neighborhood;
  - c). The compatibility of the proposed formula retail USE with the existing architectural and aesthetic character of the neighborhood;
  - d). The proposed USES contribution to the nationwide trend of standardized retail offerings that detracts from the uniqueness of Somerville's neighborhoods; and
  - e). The existing non-residential vacancy rates within the neighborhood.

d. Fresh Food Market or Grocery Store

The self-service sales of food and household products including, but not limited to, fresh and prepared meat, dairy, baked goods, fresh fruits and vegetables, canned and/or frozen foods, and other regularly consumed household products. The following standards apply:

- i. Floor area devoted to the sale of non-food items must not exceed twenty-five percent (25%) of the sales floor.
- ii. ANCILLARY prepared food and beverage service is permitted.

e. Farm or Vendor Market

The direct sales of goods and/or products by farmers or vendors to consumers from individual booths, tables, or stands, whether indoors or outdoors.

### **13. Urban Agriculture Use Categories**

a. Farming

The cultivation of soil for the production, planting, caring for, treating, growing, and harvesting of any aquacultural, horticultural, hydrocultural commodities. The specific USE types within the farming USE category are:

i. Commercial Farming

Farming for the purpose of selling produce for a profit.

- a). Sales are subject to compliance with local, state, and federal regulations.
- b). COMMERCIAL FARMING may be conducted outdoors, in a greenhouse, or on the roof of a principal or ACCESSORY STRUCTURE.

ii. COMMUNITY FARMING

FARMING by a non-profit agency with the intent of selling produce.

# 9. USE PROVISIONS

## Use Definitions & Standards

- a). Sales are subject to compliance with local, state, and federal regulations.
- b. COMMUNITY GARDENING  
The practice of growing and cultivating plants; including vegetables, flowers, and fruits; for display, enjoyment, or private/personal consumption. The following standards apply:
  - i. Sales, processing, and storage of plants or plant products are prohibited on SITE.

### 14. Accessory Use Categories

- a. The following standards apply to all ACCESSORY USES
  - i. ACCESSORY USES may not be established prior to the establishment of a PRINCIPAL USE.
- b. HOME OCCUPATIONS  
The HOME OCCUPATIONS ACCESSORY USE category includes limited business activities carried out incidental to a HOUSEHOLD LIVING PRINCIPAL USE. HOME OCCUPATIONS include, but are not limited to, the office of an architect, attorney, engineer, instructor, realtor, sales representative, software developer, teacher and their substantial equivalents that do not involve persons regularly visiting the property for business purposes, but instead primarily involves the operator visiting clients off-SITE. The following USES are not considered a HOME OCCUPATION: auto or appliance repair, contractor's shop or storage, barber shop, beauty parlors, commercial stables or kennels, medical or dental office, body art, massage, or acupuncture.
  - i. The following standards apply to all specific USE types in the HOME OCCUPATION ACCESSORY USE category:
    - a). HOME OCCUPATIONS must be operated within a completely enclosed principal or ACCESSORY BUILDING TYPE owned or occupied by the resident of the property where the HOME OCCUPATION is located.
    - b). No storage of materials, supplies, or equipment is permitted outdoors.
    - c). The production of offensive noise, vibration, glare, odors, parking/loading demands, traffic, or other negative impacts that unreasonably interfere with any person's "quiet expectations" in enjoyment of their residence is prohibited.
    - d). No display of products may be visible from the right-of-way of any public THOROUGHFARE.
    - e). SHIPPING and delivery is restricted to PARCEL and small freight carriers.
    - f). No more than one OFF-STREET PARKING SPACE is permitted for the HOME OCCUPATION.
    - g). HOME OCCUPATIONS conducted in an ACCESSORY STRUCTURE are limited in size by the provisions governing the ACCESSORY BUILDING TYPE (see Garage or Workshop).

- h). Products produced on-SITE must be grown, fabricated, or assembled by hand.
- i). HOME OCCUPATIONS USE must be operated by the occupant of DWELLING UNIT on the LOT.

The specific USE types within the HOME OCCUPATION ACCESSORY USE category are:

- ii. CREATIVE STUDIO  
A HOME OCCUPATION that generates and exploits intellectual property through individual creativity, skill, and talent; creates, produces, distributes, rehearses, performs, sells, and/or teaches the visual arts, performing arts, applied arts, literature, heritage, media, or music; or creates, produces, invents, designs, develops or prototypes content, goods, or products.
- iii. HOBBY KENNEL  
A HOME OCCUPATION involving the raising and care of four (4) or more dogs, excluding puppies younger than three (3) months, for breeding, sale, training, show, hunting, and other related purposes except boarding. The following standards apply:
  - a). No more than six (6) dogs, excluding puppies younger than three (3) months, are permitted.
  - b). All dogs must be licensed and vaccinated as required under the City's laws.
  - c). The SITE will be subject to inspection at reasonable times by the Animal Control Officer to ensure that the standards and conditions of approval of a special permit are met.
  - d). Boarding of animals or other commercial USES of the SITE are not permitted.
  - e). Dog waste must be disposed of daily, either sealed and disposed of with trash or in a maintained enzymatic dog waste system.
  - f). In addition to the review criteria for all Special Permits specified in §15.2.1.e. Review Criteria, the review board shall make findings considering the following in its discretion to approve or deny a special permit authorizing a HOBBY KENNEL HOME OCCUPATION ACCESSORY USE:
    - i). Design of confinement of dogs to the property.
    - ii). Design and size of the SITE to accommodate the safety and comfort of dogs.
    - iii). Amount of on-SITE landscaping.
    - iv). Operational procedures for controlling barking, particularly between the hours of 9:00pm and 7:00am, including hours that the dogs are outside, proper training and frequency of walks.
- iv. HOME-BASED BUSINESS  
A HOME OCCUPATION carried on by the resident of a DWELLING UNIT, where the OCCUPATION is secondary to

the USE of the DWELLING UNIT for residential purposes and where the “quiet expectations” of neighbors take precedence over work needs of the OCCUPATION in question. The following standards apply:

- a). No more than one non-resident employee may be present at any one time during the hours of operation.
  - b). Retail sales to walk-in customers are prohibited.
  - c). Client visits must be by appointment only and business activities may not have more than one (1) visitor car at a time.
- v. HOME-BASED DAY CARE
- A HOME OCCUPATION providing custodial care of children under seven (7) years of age or children under sixteen (16) years of age if such children have special needs. Home day care does not include the informal cooperative arrangement for child care among neighbors or relatives, or the occasional care of children with or without compensation. The following standards apply:
- a). Care may be provided for no more than six (6) children at a time, including any children living with the residence providing home DAY CARE SERVICES.
- vi. HOME OFFICE
- A HOME OCCUPATION conducted solely by the residents of the DWELLING UNIT without the employment of other persons. The following standards apply:
- a). All sales, services, or work that requires the presence of a partner, employee, or customer must take place off-SITE.
- c. Urban Agriculture
- The urban agriculture ACCESSORY USE category includes a range of food growing practices including FARMING and the keeping of CHICKENS and/or bees, but not other types of live stock. The specific USE types within the urban agriculture ACCESSORY USE category are:
- i. APICULTURE:  
The maintenance of honey bee colonies, commonly in hives. The following performance standards apply:
    - a). APICULTURE is subject to all applicable rules and regulations established by the Health Department of the City of Somerville.
    - b). Permitted bee species are restricted to the common domestic HONEYBEE (*Apis mellifera*).
    - c). Ownership, care, and control is the responsibility of a resident of a DWELLING UNIT on the LOT.
    - d). A maximum of two colonies may be kept on a LOT. Health regulations may further limit the number and/or manner that bees are kept.
  - e). HONEYBEES and beekeeping materials are not permitted within 20 feet of a FRONT LOT LINE.
  - f). The on SITE sale of honey produced on SITE is permitted between the hours of 7:00am to 9:00pm, May 1st through October 31st and limited to no more than 3 days per week for a total of twenty-five (25) days per year.
- ii. AVICULTURE:  
The raising and care of birds. The following performance standards apply:
  - a). AVICULTURE is subject to all applicable rules and regulations established by the Health Department of the City of Somerville.
  - b). Permitted bird species are restricted to the common domestic CHICKEN (*Gallus gallus domesticus*), specifically hens.
  - c). Roosters are prohibited.
  - d). Ownership, care, and control is the responsibility of a resident of a DWELLING UNIT on the LOT.
  - e). A maximum of six (6) hens may be kept on a LOT. Health regulations may further limit the number and/or manner that hens are kept.
  - f). Hens are not permitted within 20 feet of a FRONT LOT LINE.
  - g). The on SITE sale of eggs produced on SITE is permitted between the hours of 7:00am to 9:00pm, May 1st through October 31st and limited to no more than 3 days per week for a total of twenty-five (25) days per year.
- iii. COMMERCIAL FARMING:  
The cultivation of soil and the production, planting, caring for, treating, growing, and harvesting of any aquacultural, horticultural, and/or HYDROCULTURAL commodities. The following performance standards apply:
  - a). FARMING is subject to all applicable rules and regulations established by the Health Department of the City of Somerville.
  - b). Sales are subject to compliance with local, state, and federal regulations.
  - c). COMMERCIAL FARMING may be conducted outdoors, in a greenhouse, or on the roof of a principal or ACCESSORY STRUCTURE.
  - d). Ownership, care, and control of an outdoor, greenhouse, or roof farm is the responsibility of a resident of a DWELLING UNIT on the LOT.
  - e). The on SITE sale of agricultural commodities produced on SITE is permitted between the hours of 7:00am to 9:00pm, May 1st through October 31st and limited to no more than 3 days per week for a total of twenty-five (25) days per year.
  - f). Proof of annual soil testing is required to be



## 9. USE PROVISIONS

### Use Definitions & Standards

posted during all sales.

iv. Residential Gardening:

The practice of growing and cultivating plants; including vegetables, flowers, and fruits; for display, enjoyment, or private/personal consumption. The following performance standards apply:

- a). Sales are prohibited.
- b). Gardening may be conducted outdoors, in a greenhouse, or on the roof of a principal or ACCESSORY STRUCTURE.
- c). Ownership, care, and control is the responsibility of a resident of a DWELLING UNIT on the LOT.

d. Vehicle Parking

The vehicular parking ACCESSORY USE category includes any storage, for a limited period of time, of operable motor vehicles. The following specific vehicular parking USES are regulated differently than other USES classified within the vehicular parking ACCESSORY USE category:

i. Home Business Vehicle Parking

Parking for motor vehicles owned and operated in connection with a business in an off-STREET parking area that is ACCESSORY to a residential USE. The following standards apply:

- a). Only one business-related vehicle is permitted and must not exceed a one-ton carrying capacity.
- b). Tow-trucks are prohibited.
- c). In addition to the review criteria for all Special Permits specified in §15.2.1.e. Review Criteria, the review board shall make findings considering the following in its discretion to approve or deny a special permit authorizing a home business vehicle parking ACCESSORY USE:
  - i). Location of driveways entrances and ACCESS points in relation to the safety of pedestrians, bicyclists, and motor vehicles.
  - ii). Visual impact and quality of screening of vehicles.



# 10 DEVELOPMENT STANDARDS

<b>10.1 LAND PLATTING .....</b>	<b>439</b>	<b>10.8 SCREENING .....</b>	<b>456</b>
Development Review	439	Applicability	456
General	439	Loading Facilities	456
Thoroughfare Network	439	Service Areas	456
Blocks	439	Mechanical Equipment	456
Alley Access	439		
Lots	440	<b>10.9 COMMERCIAL SIGNS.....</b>	<b>457</b>
		Purpose	457
<b>10.2 ACCESSORY STRUCTURES.....</b>	<b>441</b>	Applicability	457
General	441	Development Review	457
Permitted Accessory Structures	441	Address Signs	457
		Exempt Signs	457
<b>10.3 LANDSCAPING .....</b>	<b>444</b>	Prohibited Signs	457
Purpose	444	Temporary Signs	458
Applicability	444	Sign Maintenance	458
Landscape Installation	444	Removal	458
Landscape Maintenance	444	Sign Illumination	458
Site Landscaping	444	Blade Sign	459
Landscape Buffers	445	Wall Sign	460
Parking Lot Landscaping	446	Awning or Canopy Sign	461
		Suspended Sign	462
<b>10.4 GREEN SCORE .....</b>	<b>447</b>	Sidewalk Sign	463
Overview	447	Window Sign	464
Applicability	447	Display Case	465
Compliance & Enforcement	447	Vertical Blade / Banner Sign	466
Calculation	447	Yard Sign	467
Eligibility	448	Wall Mural	468
Measurement	448	Roof or Skyline Sign	469
<b>10.5 OUTDOOR CAFE SEATING.....</b>	<b>449</b>	<b>10.10 STEEP SLOPES.....</b>	<b>470</b>
Applicability	449	Intent	470
Development Review	449	Purpose	470
Cafe Area Dimensions	449	Applicability	470
Furniture	449	Development Review	470
Weather Protection	450		
Enclosures	450	<b>10.11 SUSTAINABLE DEVELOPMENT.....</b>	<b>471</b>
		Applicability	471
<b>10.6 FENCES &amp; WALLS .....</b>	<b>451</b>	Green Buildings	471
Fences	451	Green Roofs & Storm Water Management	471
Retaining Walls	451	Heat Island Reduction	471
		Environmental Performance	471
<b>10.7 OUTDOOR LIGHTING .....</b>	<b>452</b>		
Intent	452	<b>10.12 WIRELESS COMMUNICATION.....</b>	<b>472</b>
Purpose	452	Purpose	472
Applicability	452	Applicability	472
Lighting Standards	452	Development Review	472
		Wireless Communication Towers	472
		Wireless Communication Antennas	472
		Ancillary Structures	473
		Design Guidelines	473
		Abandonment	473



## 10.1 LAND PLATTING

### 1. Development Review

- a. DEVELOPMENT review is subject to the provisions of Article 15: Administration of this Ordinance.
- b. Unless otherwise specified, all land platting, including SUBDIVISION, LOT SPLITS, LOT MERGERS, and LOT LINE ADJUSTMENTS, requires the submittal of a development review application to the BUILDING OFFICIAL and the issuance of a Certificate of Zoning Compliance prior any other DEVELOPMENT review.

### 2. General

- a. The SUBDIVISION of land requires SUBDIVISION Plan Approval. See §15.3.1 SUBDIVISION Plan Approval for more information.
- b. Unless otherwise specified, DEVELOPMENT SITES OVER four (4) acres in land area must be subdivided with THOROUGHFARES to create BLOCKS and LOTS conforming to the provisions of this Section.
- c. LOT SPLITS, LOT MERGERS, and LOT LINE ADJUSTMENTS require Site Plan Approval. See §15.3.2 Site Plan Approval for more information.
- d. LOT SPLITS, LOT MERGERS, and LOT LINE ADJUSTMENTS to any LOT designated as a LOCAL HISTORIC DISTRICT or identified on the Massachusetts or National Registers of Historic Places require a Special Permit.
  - i. In addition to the review criteria for all Special Permits specified in §15.2.1.e. Review Criteria, the review board shall make findings considering the following in its discretion to approve or deny a Special Permit authorizing the LOT SPLIT, LOT MERGER, OR LOT LINE ADJUSTMENT of a LOT designated as a LOCAL HISTORIC DISTRICT or identified on the Massachusetts or National Registers of Historic Places:
    - a). The recommendations of the Somerville Historic Commission.

### 3. Thoroughfare Network

- a. The general location of all proposed THOROUGHFARES must conform with official maps and exiting policy plans of the City of Somerville.
- b. All THOROUGHFARES must intersect with other THOROUGHFARES, forming a network.
- c. Where a DEVELOPMENT SITE adjoins unsubdivided land, new THOROUGHFARES must extend to or along SITE boundaries to ensure future THOROUGHFARE connections to the unsubdivided land in the event of its DEVELOPMENT.
- d. THOROUGHFARES within a DEVELOPMENT SITE must connect to any existing or proposed THOROUGHFARES on adjoining SITES.
- e. Termination of a THOROUGHFARE at a "T" intersection is permitted, provided that the overall connectivity of the THOROUGHFARE network is maintained and intersections

are adequately spaced subject to the approval by the Director of Mobility.

- f. To every extent practicable, proposed THOROUGHFARES should align with intersections on adjacent SITES to provide for the continuation of THOROUGHFARES from adjoining areas.
- g. Cul-de-sacs and other dead-end THOROUGHFARES are prohibited.
- h. THOROUGHFARES must be permanently open and provide public ACCESS as part of an overall connected THOROUGHFARE network.
- i. The Planning Board may waive the intersection requirements of §13.3.3.g on a case-by-case basis to accommodate specific SITE conditions.

### 4. Blocks

- a. Unless otherwise specified, BLOCKS must have individual BLOCK FACES no greater than five-hundred (500) feet and a total perimeter no greater than sixteen-hundred (1,600) feet.
- b. BLOCK FACES are measured as the aggregate of all FRONT LOT LINES and the width of ALLEYS, if present, on one side of a BLOCK.
- c. BLOCK perimeter is measured as the aggregate of all BLOCK FACE lengths of an individual BLOCK.
- d. BLOCKS should be rectangular in shape, but are expected to respond to natural features.
- e. The Planning Board may waive BLOCK size requirements for portions of DEVELOPMENT SITES ABUTTING areas of undeveloped land, areas unsuitable for DEVELOPMENT, pre-existing incomplete BLOCKS, OR RAIL RIGHTS-OF-WAY.
- f. BLOCK dimensions may be calculated at a reduced BLOCK FACE or perimeter length where a mid-BLOCK passage connecting opposite sides of a BLOCK is installed as a dedicated right-of-way or reserved with a permanent ACCESS EASEMENT.

### 5. Alley Access

- a. BLOCKS may be ACCESSED by ALLEYS in one of the configurations defined below:
  - i. Common BLOCK: A BLOCK where parking and service areas internal to the BLOCK are shared among several LOTS and buildings.
  - ii. H - BLOCK: A BLOCK with three ALLEYS that intersect to form an "H"; allowing DEVELOPMENT to front on four BLOCK FACES.
  - iii. T - BLOCK: A BLOCK with two perpendicular ALLEYS that intersect to form a "T"; allowing DEVELOPMENT to front on three BLOCK FACES.
  - iv. I - BLOCK: A BLOCK with one ALLEY servicing LOTS on either side of a BLOCK, allowing DEVELOPMENT to front on two BLOCK FACES.

# 10. DEVELOPMENT STANDARDS

## Land Platting

- b. To every extent possible, ALLEY ACCESS into BLOCKS should be aligned on OPPOSITE BLOCK FACES as well as with ALLEYS on OPPOSITE sides the STREET.

### 6. Lots

- a. All LOTS must have frontage on a CIVIC SPACE or a THOROUGHFARE, excluding ALLEYS.
  - i. LOTS ABUTTING only a CIVIC SPACE at the FRONT LOT LINE must also ABUT an ALLEY at the rear or side.
- b. LOTS must have a LOT WIDTH and LOT DEPTH appropriate for one or more of the BUILDING TYPE(s) permitted for the district where the LOT is located.
- c. Unless otherwise specified, LOTS may be platted to create a CORNER, INTERIOR, OR KEY LOT.
- d. FLAG LOTS are prohibited.
- e. THROUGH LOTS are prohibited, except for LOTS intended as a Through Block Plaza CIVIC SPACE type or a BLOCK BUILDING BUILDING TYPE.
- f. To avoid creating irregular LOT shapes, LOTS must be platted to be generally rectilinear, where the SIDE LOT LINES are within 45 degrees of perpendicular to the FRONT LOT LINE or to the tangent of a curved FRONT LOT LINE, and generally straight throughout their length.

## 10.2 ACCESSORY STRUCTURES

### 1. General

- a. All DEVELOPMENT, excluding NORMAL MAINTENANCE, requires the submittal of a development review application to the BUILDING OFFICIAL and the issuance of a Certificate of Zoning Compliance prior to the issuance of a Building Permit or Certificate of Occupancy.
- b. Unless otherwise specified, ACCESSORY structures are permitted by-right.
- c. ACCESSORY structures may not be constructed prior to the following:
  - i. construction of a PRINCIPAL BUILDING; or
  - ii. issuance of a special permit for an ACCESSORY USE, as applicable.
- d. The BUILDING OFFICIAL shall determine when a structure is ACCESSORY to the PRINCIPAL BUILDING of a LOT. To determine that a structure is Worry, the BUILDING OFFICIAL must find that the structure:
  - i. is customarily found in association with a permitted principal or ACCESSORY USE;
  - ii. is clearly incidental and subordinate to the PRINCIPAL BUILDING in terms of area, size, function, and location; and
  - iii. is operated and maintained under the same ownership as the PRINCIPAL BUILDING.
- e. Unless otherwise specified, ACCESSORY structures are permitted to ENCROACH any side or rear SETBACK, provided that at least three (3) feet is maintained from the vertical plane of any LOT LINE.
- f. ACCESSORY structures are not permitted to ENCROACH into any maximum front SETBACK.

### 2. Permitted Accessory Structures

- a. Amateur Radio Equipment
 

ANTENNAS located on ground-mounted TOWERS and roof-mounted support structures USED to broadcast an amateur (ham) radio station licensed by the Federal Communications Commission (FCC). The following standards apply:

  - i. Ground-mounted TOWERS are permitted only in the rear yard and must be located a minimum of ten feet from any LOT LINE and any overhead electric distribution or transmission lines. The TOWER must be fully enclosed by a fence or wall of at least four feet in height.
  - ii. Ground-mounted TOWERS may not exceed thirty-five (35) feet, measured from the base of the supporting TOWER to its tallest point.
  - iii. A roof-mounted ANTENNA, when fully extended, is limited to a maximum height of ten feet above the height of the structure to which it is mounted.
  - iv. No more than one ANTENNA, whether ground-mounted or roof-mounted, is permitted per LOT.

- b. Apiary
 

A structure for the keeping of HONEYBEES. The following standards apply:

  - i. Apiaries and other beekeeping supplies are not permitted within twenty (20) feet of a FRONT LOT LINE.
- c. ARBOR
 

A structure with an open frame, freestanding or attached to another structure, with horizontal or vertical latticework often USED as a support for ornamental vines and/or climbing plants. The following standards apply:

  - i. ARBOR are not permitted to exceed eight (8) feet in height.
- d. CARPORT
 

A roofed structure, whether attached to or detached from a PRINCIPAL BUILDING, that provides protection from the weather and is USED for overnight parking of up to two (2) motor vehicles. The following standards apply:

  - i. A CARPORT must be set back at least 20 feet from any FRONT LOT LINE.
  - ii. Where an improved ALLEY is available, vehicular ACCESS to the CARPORT must take place from the ALLEY.
  - iii. A CARPORT may be a maximum of fifteen (15) feet in height and no more than twenty-four (24) feet in width and depth.
  - iv. A CARPORT must be set-back a minimum of three (3) feet from any side or REAR LOT LINE unless constructed of fireproof materials.
- e. CHICKEN Coop (Hen House)
 

A structure for the keeping of CHICKENS, with nest boxes for egg-laying and perches where the birds can sleep. The following standards apply:

  - i. CHICKEN coops are not permitted within twenty (20) feet of a FRONT LOT LINE.
- f. Cold Frame
 

An unheated outdoor STRUCTURE built close to the ground, typically consisting of, but not limited to, a wooden or concrete frame and a top of grass or clear plastic USED for protecting seedlings and plants from cold weather. The following standards apply:

  - i. Cold frames are not permitted to exceed six and one-half (6.5) feet in height.
  - ii. Any plastic covering of a cold frame must be removed and stored when plant cultivation is not in process.
- g. Compost Bin
 

An outdoor container in which garden refuse and other organic waste is deposited in order to produce compost. The following standards apply:

  - i. Compost bins must have a ground gate and pest proof lids.

# 10. DEVELOPMENT STANDARDS

## Accessory Structures

- h. Construction Trailer or Office  
A temporary STRUCTURE providing office space for project management at a construction SITE. The following standards apply:
  - i. Construction trailers and/or offices must comply with the SETBACKS applicable to PRINCIPAL BUILDINGS for the appropriate district.
- i. Donation Box  
A container, usually made of metal, with a one-way drop to allow donation of household items. The following standards apply:
  - i. Donation boxes are not permitted in the Neighborhood Residence or Urban Residence districts.
  - ii. Only one (1) donation box is permitted per LOT.
  - iii. Containers must be watertight and secured to the ground.
- j. FARM STAND  
A temporary STRUCTURE for the display and sale of clean, whole, unprocessed produce, eggs, or honey cultivated on SITE. The following standards apply:
  - i. One (1) FARM STAND is permitted per LOT.
  - ii. Product display & area for retail sales is not permitted to exceed fifty (50) square feet.
  - iii. The FARM STAND, associated product display, and SIGNAGE must be stored out of sight when not in USE.
- k. Gazebo  
A STRUCTURE covered by a roof, occasionally enclosed with screening, and intended for outdoor recreational USE.
- l. Greenhouse  
A STRUCTURE, primarily of transparent material, in which temperature and humidity can be controlled for the cultivation or protection of plants or other horticultural products.
  - i. Green houses on the roofs of buildings must be located at least five (5) feet from the edge of the roof and are limited to a maximum of eighteen (18) feet in height above the surface of the roof.
- m. Hoop House  
A STRUCTURE typically made of, but not limited to, piping or other material covered with a translucent material for the purpose of growing food or ornamental crops. The following standards apply:
  - i. A hoop house is limited to six and one-half (6.5) feet in height.
  - ii. The covering of a hoop house must be removed and stored when plant cultivation is not in process.
- n. Market Stand  
A partially-enclosed STRUCTURE USED for outdoor retail sales.
- o. Pergola  
A STRUCTURE consisting of parallel colonnades supporting an open roof or girders and cross rafters, often shading an outdoor amenity area.
- p. Pool or Hot Tub  
A STRUCTURE filled with water USED for recreation or physical therapy. The following standards apply:
  - i. Pools and hot tubs must be set-back at least five (5) feet from a side or REAR LOT LINE and ten (10) feet from a FRONT LOT LINE.
  - ii. Uncontrolled ACCESS to pools or hot tubs must be prevented using a wall, fence, or other acceptable means.
- q. Real Estate Trailer or Office  
A temporary STRUCTURE providing office space for the sale or rental of real estate at a construction SITE. The following standards apply:
  - i. Real Estate trailers and/or offices must comply with the SETBACKS applicable to PRINCIPAL BUILDINGS for the appropriate district.
  - ii. Sleeping and cooking facilities are prohibited.
- r. Satellite Dish  
A dish ANTENNA for transmitting SIGNALS to a receiver or receiving station or for receiving television, radio, data, communication, or other SIGNALS from other ANTENNAS, satellites, or services. Small satellite dish ANTENNAS are one meter or less in diameter and large satellite dish ANTENNAS exceed one meter in diameter. The following standards apply:
  - i. One (1) satellite dish is permitted per unit.
  - ii. Satellite dish ANTENNAS must be permanently installed as BUILDING-mounted or ground-mounted STRUCTURES and must not be portable or movable.
  - iii. BUILDING-mounted satellite dishes may not be installed on any FACADE unless such placement is required for reception of an acceptable SIGNAL, according to a written statement from a licensed, authorized installer on company letterhead that includes the installer's SIGNATURE.
  - iv. Roof-mounted satellite dish ANTENNAS must be located a minimum of five feet from any roof edge.
  - v. Large satellite dish ANTENNAS are permitted only in rear yards, and must be set back from all LOT LINES a distance that is at least equal to the height of the dish, or five feet, whichever is less.
- s. Shed  
A roofed STRUCTURE USED as a storage space. The following standards apply:
  - i. Sheds larger and one hundred and twenty (120) square feet and fifteen (15) feet in height are prohibited.
- t. Solar Collector  
Any of a variety of STRUCTURES designed to absorb solar radiation for the purpose of heating water or buildings or the producing electricity.
- u. Temporary Shelter



A temporary moveable or wheeled structure used as a residence. The following standards apply:

- i. Occupancy is permitted as a Household Living us, but is restricted to a maximum of twelve (12) consecutive months during the reconstruction of a PRINCIPAL BUILDING OR ACCESSORY BUILDING after a fire or catastrophe.

v. Trellis

A structural framework of latticework that is at least 50% open, typically made of bars of wood or metal crossed over each other, and chiefly used as a support for vines, fruit trees, or climbing plants. The following standards apply:

- i. A trellis is limited to a maximum height of eight (8) feet.

# 10. DEVELOPMENT STANDARDS

## Landscaping

### 10.3 LANDSCAPING

#### 1. Purpose

- a. To ensure vegetation is properly planted and installed in a timely manner.
- b. To increase the compatibility of DEVELOPMENT in adjacent zoning districts, minimize the potential adverse impacts of adjacent land USES, increase privacy, and minimize the trespass of undue sound and light between adjacent properties.
- c. To protect existing trees and expand the city's mature tree canopy in order to enhance the quality of life within Somerville.
- d. To promote a healthy urban forest.

#### 2. Applicability

- a. This section is applicable to all DEVELOPMENT involving the construction of a new PRINCIPAL BUILDING, SITE IMPROVEMENTS, or the construction or reconstruction of a SURFACE PARKING LOT OR CIVIC SPACE.
- b. MODIFICATIONS to an existing PRINCIPAL BUILDING TYPE, the addition of Building COMPONENTS and frontages to an existing PRINCIPAL BUILDING TYPE, changes in USE, and the construction of a new ACCESSORY STRUCTURES are permitted without triggering the standards of this section.
- c. NORMAL MAINTENANCE of a existing PRINCIPAL BUILDING TYPE including, but not limited to painting, roof replacement, re-siding, window replacement, and other improvements deemed to be cosmetic in nature by the BUILDING OFFICIAL, is permitted without triggering the standards of this section.
- d. Resealing or re-stripping of a PARKING LOT, which does not entail paving, resurfacing, or replacement of the asphalt, concrete, or other surface paving material, is permitted without triggering the standards of this section.
- e. When compliance is triggered for an existing SURFACE PARKING LOT, the landscape standards of this section take precedence over parking standards found elsewhere in this Ordinance.

#### 3. Landscape Installation

- a. National Standards
  - i. Vegetation and other horticultural materials must be installed in accordance with the latest edition of the American Standard for Nursery Stock published by American Hort.
- b. Installation Prior to Occupancy
  - i. Landscaping required by this Ordinance must be completed prior to the issuance of a Certificate of Occupancy by the BUILDING OFFICIAL.
  - ii. If seasonal or abnormally inclement weather conditions preclude complete installation, the

BUILDING OFFICIAL may grant a Certificate of Occupancy if the APPLICANT provides letter of commitment to complete installation by the next planting season.

#### 4. Landscape Maintenance

- a. All vegetation must be maintained in healthy, growing condition at all times by the PROPERTY OWNER(s) or their designated agent(s).
- b. Turf grass must be mowed and edged; PLANTING BEDS must be weeded, and kept free of litter; all trees, hedges, bushes, SHRUBS, and other vegetation must be trimmed to prevent ENCROACHMENT by growth that obstructs USE of the sidewalk of any public THOROUGHFARE by pedestrians in any way.
- c. Vegetation that is significantly damaged, missing, infested, disease-ridden, or dead must be replaced within one (1) year or by the next planting season, whichever occurs first.
- d. Vegetation that is deemed hazardous or unsafe or that interferes with public utilities must be abated by the PROPERTY OWNER as soon as practicable or within thirty (30) days of notice by the BUILDING OFFICIAL.
- e. The BUILDING OFFICIAL may remove any landscaping that is an immediate peril to persons or property summarily, without notice, and at the PROPERTY OWNER'S expense.

#### 5. Site Landscaping

- a. Ground Treatment
  - i. LOT AREA uncovered by structures or impermeable surfaces must be landscaped with one (1) or more of the following treatments:
    - a). Urban agricultural activities subject to Article 9. Use Provisions;
    - b). Seeded or sodded turfgrass maintained until coverage is complete;
    - c). GROUNDCOVERS appropriate for the location that are sized and spaced to provide at least fifty percent (50%) coverage after the first full growing season and complete coverage at maturity;
    - d). Bushes, SHRUBS, vines, flowers, and other horticultural materials that are sized and spaced to provide at least fifty percent (50%) coverage at the time of planting with the remaining area covered by COARSE GRADE GROUNDCOVER MULCH;
    - e). Trees;
    - f). Permeable, pervious, or porous pavements with appropriate bedding and an aggregate sub-base;
    - g). Inorganic surfacing such as crushed stone,

# 10. DEVELOPMENT STANDARDS

## Landscaping

- gravel, shell, pea gravel, and washed stone covering no more than ten percent (10%) of the uncovered LOT AREA in total.
  - ii. Trails; naturally occurring stream beds, rock outcroppings, and similar features typically lacking in vegetation; clay or sand surfaces associated with athletic fields; and water features are exempt.
  - b. Trees
    - i. New trees must have a minimum height of ten (10) feet or be two (2) inches in CALIPER when planted.
    - ii. The root flare of new trees must be exposed and planted at grade.
    - iii. New trees may not have a significant negative impact on any ABUTTING properties when fully grown, such as shading a solar collector existing at the time the tree is planted.
  - c. Soils
    - i. Vegetation must be planted in soil of sufficient volume, composition, and nutrient balance to sustain health growth.
    - ii. Soils must be appreciably free of gravel, stones, rubble, or trash.
    - iii. All compacted soil, contaminated soil, or road base fill must be removed.
  - d. Mulch
    - i. GROUNDCOVER MULCHES certified by the Mulch & Soil Council are highly recommended.
    - ii. The USE of fine grade and shredded soil conditioning mulches as GROUNDCOVER MULCH is prohibited.
    - iii. Mulch made from cypress, cocoa shells, and rubber is prohibited.
  - e. Spacing
    - i. The spacing and placement of plants must be adequate and appropriate for the typical size, shape, and habit of the plant species at maturity.
  - f. Weather Protection
    - i. LANDSCAPE AREAS within six (6) feet of a paved vehicular parking area or roadway of a THOROUGHFARE must be raised or protected by curbing or edging at least six (6) inches in elevation above the finished pavement to protect plantings from traffic, de-icing salts, and snow plowing operations common to the winter season.
  - g. Water features
    - i. Constructed water features such as pools, fountains, and ponds that operate with water recirculation systems must be designed to prevent seepage and leaks.
  - h. Restrictions
    - i. Invasive plant species to the State of Massachusetts are prohibited and must be removed if already existing on a DEVELOPMENT SITE.
    - ii. Vegetation with spines, thorns, or needles that may present hazards to pedestrians are prohibited from within two (2) feet of any FRONT LOT LINE.
  - iii. Nothing but GROUNDCOVER less than six (6) inches in height may be planted or installed within any underground or overhead utility or drainage EASEMENT without consent of the utility provider or EASEMENT holder and the City of Somerville.
  - iv. Nothing but GROUNDCOVER less than six (6) inches in height may be planted or installed within three (3) feet of any fire protection system.
  - v. Artificial plants and artificial turf are prohibited, excluding athletic fields that are subject to intense USE and soil compaction that prohibits the establishment of turf grass and areas where paving or grass paving systems will not suffice given the area's purpose and level of USE.
- ### 6. Landscape Buffers
- a. General
    - i. Any LOT ABUTTING the side or REAR LOT LINE of a LOT in the NR district must be screened by a landscape buffer.
  - b. Type
    - i. Landscape buffers must be designed as a Type A or Type B buffer in accordance with Table 10.3.1.
  - c. Buffer Design Standards
    - i. Landscape buffers must be located along the outer perimeter of the LOT, parallel to and extending along one hundred percent (100%) of the length of the shared LOT LINE.
    - ii. Three (3) SMALL TREES with a minimum CALIPER of one and one-half (1.5) inches may be substituted for each required LARGE TREE.
    - iii. SHRUBS must be of at least a five (5) gallon container size when planted and at least seventy five percent (75%) of all SHRUBS must be evergreen.
    - iv. Required trees and SHRUBS may be installed at varying distances to create a naturalistic landscape design, so long as the per linear foot requirement is applied as an average, and the landscape is arranged to provide sufficient screening.
    - v. Fences and walls must be positioned exterior to required landscaping and are subject to the provisions of §10.6. Fences & Walls.
    - vi. Preexisting, substantially equivalent vegetation that is preserved within the landscape buffer may substitute for any required landscape buffer plantings provided that the preexisting vegetation is healthy and growing.
    - vii. Water, sanitary sewer, electrical, telephone, natural gas, cable, storm drainage, or other service lines are permitted within landscape buffers.
    - viii. SURFACE PARKING is prohibited within a required landscape buffer.

# 10. DEVELOPMENT STANDARDS

## Landscaping

**Table 10.3.1 Landscape Buffers**

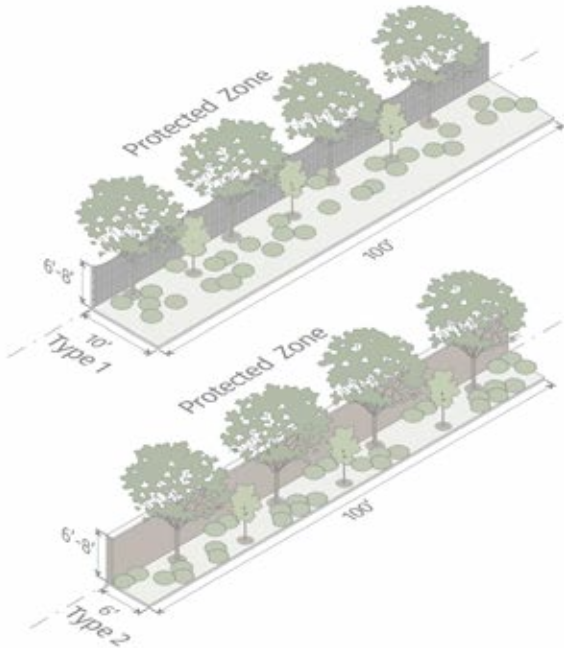

	Type A	Type B
Depth (min)	6 feet	6 feet
Fence/Wall Type	n/a	Fully Closed
Fence/Wall Height (min)	n/a	6 feet
LARGE TREES (min per 100 ft)	3	n/a
SHRUBS (min per 100 ft)	33	33

### 7. Parking Lot Landscaping

- a. General
  - i. The landscape standards of this section take precedence over parking standards found elsewhere in this Ordinance.
- b. Perimeter Planting
  - i. SURFACE PARKING must be screened from view along any LOT LINE ABUTTING a public THOROUGHFARE, excluding and ALLEY, using one of the following landscape buffers:
    - a). Landscape Strip with SHRUBS
      - i). A minimum six (6) foot wide landscape strip planted with a continuous row of SHRUBS and one (1) tree per thirty (30) feet of LOT LINE.
      - ii). SHRUBS must be of at least a five (5) gallon container size when planted and at least seventy five percent (75%) of all SHRUBS must be evergreen.
      - iii). Breaks for vehicular and pedestrian ACCESS are permitted.
    - b). Landscape Strip with Fence
      - i). A minimum six (6) foot wide landscape strip planted with a minimum three (3) foot tall fence and one (1) tree per thirty (30) feet of LOT LINE.
      - ii). Fencing must be generally designed as metal fence panels between masonry pillars and constructed of permanent, durable materials, such as brick, stone, iron, steel, or aluminum.
      - iii). Breaks for vehicular and pedestrian ACCESS are permitted.

- c. Landscape Islands
  - i. A landscape island must be provided every five (5) parking spaces and at the end of every row of parking spaces.
  - ii. Landscape islands may be consolidated and intervals may be adjusted as necessary to preserve existing trees or facilitate storm water management.
  - iii. Landscape islands ABUTTING a single row of parking spaces must be at least eight (8) feet in width and the same length as the parking spaces. Each island must include one (1) LARGE TREE.
  - iv. Landscape islands ABUTTING a double row of parking spaces must be at least eight (8) feet in width and the same length as the parking spaces. Each island must include two (2) LARGE TREES.

## 10.4 GREEN SCORE

### 1. Overview

- a. GREEN SCORE is an performance-based environmental landscape standard measured as a ratio of the weighted value of all landscape elements to the total land area (in square feet) of a LOT.
- b. Calculation of the GREEN SCORE USES a value based system to incentivize landscape elements and SITE design that contributes to the reduction of storm water runoff, the improvement of urban air quality, mitigation of the urban HEAT ISLAND effect, and improved well-being of residents and visitors.
- c. The result of the green factor calculation relates to an increase in the environmental performance and quality of urban landscape features.

### 2. Applicability

- a. This section is applicable to the construction of any new PRINCIPAL BUILDING and any SUBSTANTIAL REHABILITATION of a PRINCIPAL BUILDING.

### 3. Compliance & Enforcement

- a. Real property must comply with the GREEN SCORE indicated for each BUILDING TYPE. See the standards for each BUILDING TYPE in each zoning district for more information.
- b. The BUILDING OFFICIAL shall establish standards for the administration of this Section.

### 4. Calculation

- a. GREEN SCORE is calculated as follows:
  - i. Determine total LOT AREA.
  - ii. Calculate the area of each proposed landscape element for each category identified in the first column of Table 10.4.1. Certain types of plantings USE the number of individual plants multiplied by an equivalent square footage when indicated in the second column of Table 10.4.1.
  - iii. Multiply the area in square feet, or the equivalent square footage, of each landscape element by the assigned multiplier identified in the third column of Table 10.4.1 plus any bonus on Table 10.4.2 to determine the weighted score of each element.
  - iv. Add the weighted score of all landscape elements together.
  - v. Divide the resulting sum by the area of the LOT to determine the final GREEN SCORE.
  - vi. If necessary, redesign the landscape plan to achieve the required GREEN SCORE.
- b. BONUSSES
  - i. Review Boards may establish additional BONUSSES than those listed on Table 10.4.2 to achieve other city policy objectives based on the

**Table 10.4.1 Green Score Calculation**

	Credit	Multiplier
<b>Soils</b>		
Landscaped area with a soil depth < 24 inches	actual sf	0.3
Landscaped area with a soil depth => 24 inches	actual sf	0.6
Pervious Paving with 6 to 24 inches of subsurface soil or gravel	actual sf	0.2
Pervious Paving with more than 24 inches of subsurface soil or gravel	actual sf	0.5
<b>GROUNDCOVERS</b>		
Turfgrass, mulch, and inorganic surfacing materials	actual sf	0.1
<b>Plants</b>		
Vegetation less than two (2) feet tall at maturity	actual sf	0.2
Vegetation at least two (2) feet tall at maturity	12 sf.	0.3
<b>Trees</b>		
SMALL TREE	50 sf.	0.6
LARGE TREE	450 sf.	0.6
Preserved Tree	65 sf.	0.8
<b>Engineered Landscape</b>		
Vegetated Wall	actual sf	0.7
Rain gardens, bioswales, and stormwater PLANTERS.	actual sf	1.0
Green Roof with up to 6" of growth medium	actual sf	0.2
Green Roof with 6"-10" of growth medium	actual sf	0.4
Green Roof of 10"-24" growth medium	actual sf	0.6
Green Roof of over 24" growth medium	—	per individual landscape elements

# 10. DEVELOPMENT STANDARDS

## Green Score

recommendations of the Director of Public Space & Urban Forestry.

- ii. Each additional bonus may have a multiplier up to one-tenth (0.1) for each bonus.

### 5. Eligibility

- a. All landscape elements must meet eligibility and quality standards established by the Director of Public Space and Urban Forestry to ensure the long-term health, viability, and coverage of plantings.

### 6. Measurement

- a. If multiple landscape elements identified in the first column of Table 10.4.1 occupy the same area, for example GROUNDCOVER under a tree, the full square footage or equivalent square footage of each element is counted.
- b. For trees, large SHRUBS, and large perennials, USE the equivalent square footage indicated on Table 10.4.1.
- c. For vegetated walls, the area calculated is the height times the width of the area to be covered by vegetation.
- d. For all elements other than trees, large SHRUBS, large perennials, and vegetated walls, square footage is calculated as the area of a horizontal plane that is over the landscape element.
- e. Landscape elements may qualify for bonus credits in addition to the standard green factor categories used to determine the green factor score.

**Figure 10.4.1 Stacking of Landscape Elements**

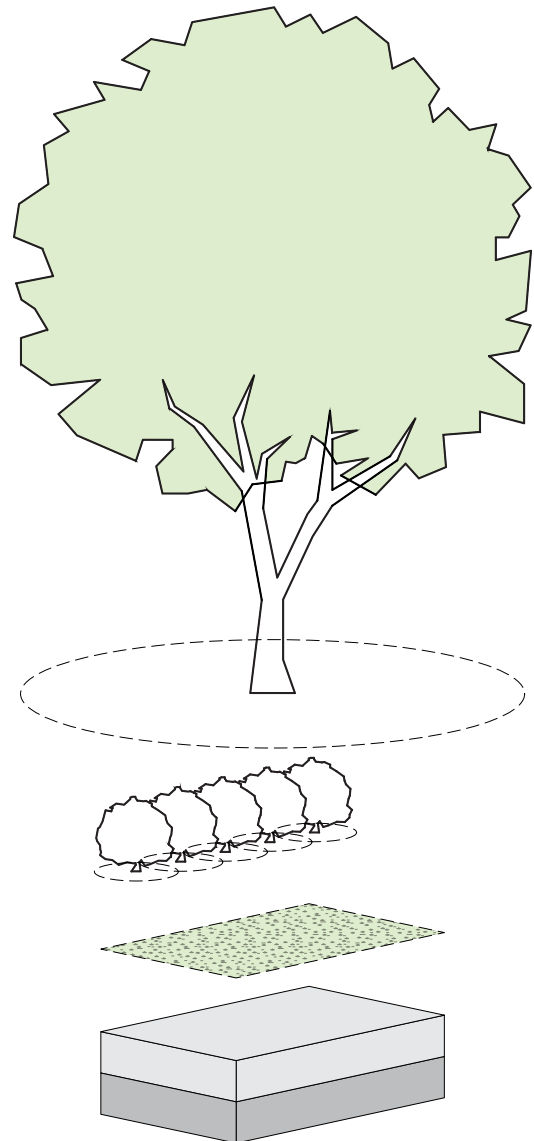

**Table 10.4.2 Green Score Bonuses**

	Credit	Multiplier
<b>Bonus Credits</b>		
Publicly visible landscape	--	0.1
Native species	--	0.1
High value species	--	0.1
50% of irrigation is harvested rainwater	--	0.1
Food cultivation	--	0.1
De-paved LOT AREA	--	0.1



## 10.5 OUTDOOR CAFE SEATING

### 1. Applicability

- a. This section is applicable to all OUTDOOR CAFE SEATING located in a FRONTAGE AREA or on a public sidewalk.

### 2. Development Review

- a. OUTDOOR CAFE SEATING is permitted by Site Plan Approval only as an ANCILLARY activity of any Food & Beverage Service PRINCIPAL USE.

### 3. Cafe Area Dimensions

- a. OUTDOOR CAFE SEATING areas must be between six (6) feet and fifteen (15) feet in depth from the FACADE the BUILDING.
- b. A minimum four (4) foot wide clear path of ACCESS must be maintained to the PRINCIPAL ENTRANCE.
- c. OUTDOOR CAFE SEATING must be located adjacent to and may not extend beyond the establishment it serves.
- d. OUTDOOR CAFE SEATING areas must comply with the sidewalk standards of Article 8 PUBLIC REALM Standards.

### 4. Furniture

- a. Furnishings may only consist of moveable tables, moveable chairs, moveable umbrellas, required enclosures, and portable or mounted heaters.
- b. All furnishing must be commercial grade and manufactured for outdoor use of safe, sturdy, and durable materials, such as wood, steel, or wrought iron.
- c. When not intended for use during the winter months, outdoor cafe furnishings must be removed and stored indoors.
- d. Tables and chairs for each establishment must match in material and style.
- e. Tables larger than three (3) feet six (6) inches in width or diameter are not permitted.
- f. Standing or stooled table ledges, if provided, must be eighteen (18) inches in depth.
- g. Heaters are encouraged to extend the USE of OUTDOOR CAFE SEATING during colder weather. The following standards apply:

Figure 10.5.1 Outdoor Cafe Seating

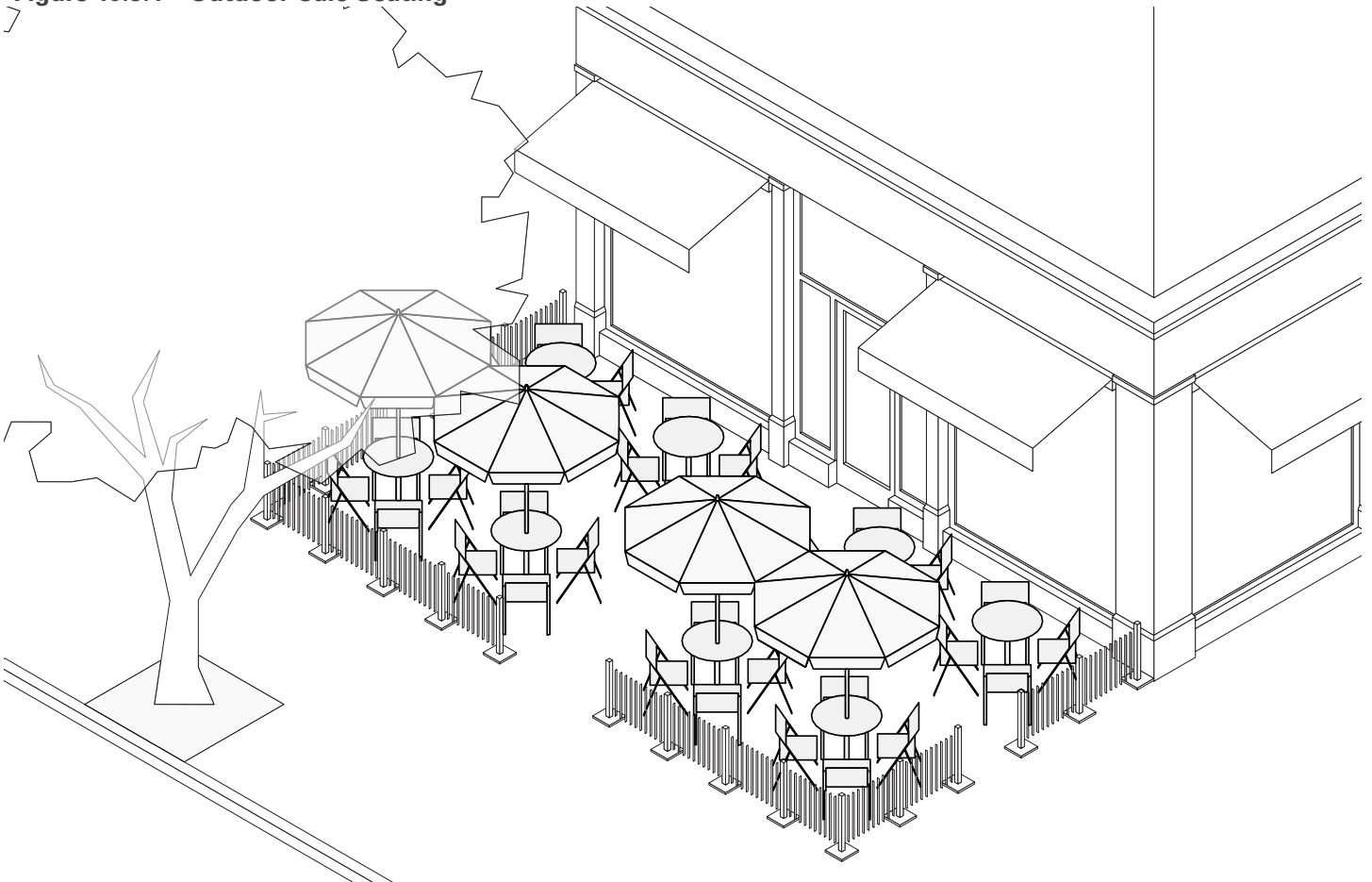

## 10. DEVELOPMENT STANDARDS

### Outdoor Cafe Seating

- i. Heating fixtures require approval by the Fire Department.
  - ii. Heaters may be freestanding or mounted to the underside of an awning.
  - iii. Portable heaters must be stored indoors when the business is closed.
- h. Host stands should complement the chairs and tables in material and style.

#### 5. Weather Protection

- a. Awnings or individual table umbrellas are encouraged to provide protection from the weather.
- i. Awnings must be secured to a storefront or other exterior wall of a BUILDING.
  - ii. Awnings and umbrellas should be canvas or other non-vinyl material.
  - iii. Awnings and umbrellas should provided shade for at least fifty percent (50%) of the OUTDOOR CAFE SEATING when provided.
- b. Vertical wind breaks may be provided on each end of the cafe area, provided that the wind break is attached to and fits completely under an awning.
- c. Any necessary frames or supports for awnings or windbreaks are permitted.

#### 6. Enclosures

- a. The perimeter of OUTDOOR CAFE SEATING areas must be defined and enclosed on all sides by any combination of metal fencing, bollards and chain, or PLANTERS.
- b. Metal Fencing
- i. Fencing must be thirty-six (36) inches or less in height.
  - ii. The maximum gap permitted between fence segments is four (4) inches.
- c. Bollards & Chain
- i. Metal or wooden bollards must be thirty-six (36) inches or less in height.
  - ii. Bollards may be linked with rope or chain that hangs no less than thirty (30) inches from the ground at its lowest point.
- d. PLANTER Boxes
- i. PLANTERS OF PLANTER enclosures must be between eighteen (18) inches and twenty-four (24) inches in height.
  - ii. The combined height of PLANTERS and live plants must not exceed four (4) feet from sidewalk grade.
  - iii. Healthy, living plants are required.
  - iv. PLANTERS and flower boxes must be made of safe, durable materials manufactured for outdoor USE.

## 10.6 FENCES & WALLS

### 1. Fences

- a. General
  - i. Fences may be placed up to and along any LOT LINE.
  - ii. Fences installed directly onto a shared side or REAR LOT LINE require consent of the ABUTTING PROPERTY OWNER.
  - iii. Fences do not require a Building Permit and are ERECTED at the owners risk.
  - iv. Fence posts or supporting rails must face inward toward the property being fenced and the finished face must be oriented towards the adjacent property.
- b. INTERIOR LOTS (see Fig. 10.6.1)
  - i. Fences located in the FRONTAGE AREA of a LOT may be a maximum of four (4) feet in height and no more than fifty percent (50%) opaque.
  - ii. Fences located behind the FRONTAGE AREA, internal to the LOT, may be a maximum of six (6) feet in height, unless required as screening (see §10.8 Screening).
- c. CORNER LOTS (see Fig. 10.6.2)
  - i. Fences located in the FRONTAGE AREA of a LOT, for both the primary and secondary frontage, may be a maximum of four (4) feet in height and no more than fifty percent (50%) opaque.
  - ii. Fences located behind the FRONTAGE AREA, internal to a LOT, may be a maximum of six (6) feet in height, unless required as screening (see §10.8 Screening).
- d. Architectural Fence Features
  - i. Fence and gate posts that are architectural features

integrated into the design of a fence are permitted up to four and one half (4.5) feet for fences in the FRONTAGE AREA and up to six and one half (6.5) feet in height for fences behind the FRONTAGE AREA.

- e. Restrictions
  - i. Fences are prohibited within any existing or required drainage or utility EASEMENT.
  - ii. Barbed wire and concertina wire are prohibited.
- f. Privacy Fencing
  - i. The Review Boards may require fences located behind the FRONTAGE AREA, internal to a LOT, to be up to a maximum of eight (8) feet in height as a condition of the issuance of a Special Permit or Site Plan Approval to address privacy concerns of neighbors.

### 2. Retaining Walls

- a. Any portion of a RETAINING WALL that exists above the ground level of a higher grade must comply with the requirements for fences (see §10.6.1 Fences above).
- b. When provided, RETAINING WALLS located in the FRONTAGE AREA may be a maximum of four (4) feet in height and successive walls must be built with a minimum horizontal separation distance of four (4) feet.
- c. RETAINING WALLS may be built to any height behind the FRONTAGE AREA.

**Figure 10.6.1 Fencing - Interior Lots**

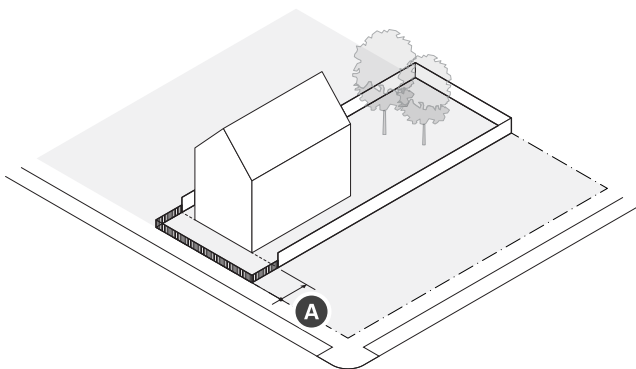

**Figure 10.6.2 Fencing - Corner Lots**

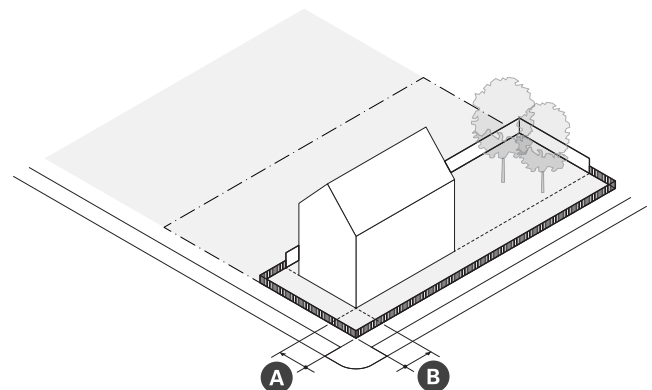

# 10. DEVELOPMENT STANDARDS

## Outdoor Lighting

### 10.7 OUTDOOR LIGHTING

#### 1. Intent

- a. To increase night sky visibility, improve nighttime vision and the color rendition of outdoor light, and reduce the impacts of outdoor lighting for people and wildlife.
- b. To conserve energy and reduce the consumption of electricity for lighting purposes.

#### 2. Purpose

- a. To reduce light pollution and glare from outdoor lighting fixtures and reduce excessive light levels as existing fixtures are replaced over time.
- b. To permit the use of outdoor lighting that does not exceed the minimum levels specified by recommended practices of the Illuminating Engineering Society (IES) for night-time safety, utility, security, productivity, enjoyment, and commerce.
- c. To minimize adverse impacts of lighting such as light trespass, obtrusive light spillover, and harmful glare.
- d. To curtail light pollution, reduce sky-glow, and improve the nighttime environment.

#### 3. Applicability

- a. This section is applicable to all outdoor lighting fixtures, except for the following:
  - i. Lighting within rights-of-way or EASEMENTS for the principal purpose of illuminating STREETS, ALLEYS, mid-BLOCK passages, or CIVIC SPACES;
  - ii. SIGN lighting (see §10.9. SIGNS);
  - iii. Lighting for public monuments and statuary;
  - iv. Holiday lighting;
  - v. Outdoor lighting USED for emergency equipment and work conducted in the interest of law enforcement or for public health, safety, or welfare;
  - vi. Underwater lighting;
  - vii. Temporary lighting for theatrical, television, performance areas and construction SITES; and
  - viii. Low voltage landscape lighting controlled by an automatic device that is set to turn the lights off at one hour after the SITE is closed to the public.

#### 4. Lighting Standards

- a. General
  - i. Outdoor lighting is regulated by the amount of light emitted, the color temperature of light, and the design of light fixtures to achieve certain desired environmental characteristics.
- b. Amount of Light Emitted
  - i. The following standards are applicable for all permitted BUILDING TYPES in the NR district and all permitted BUILDING TYPES, excluding Apartment Buildings, in the UR district:
    - a). At installation, individual LUMINAIRES may not

exceed the LUMEN limits specified on Table 10.7.1 (a) Permitted Lumes.

- ii. The following standards are applicable to all other buildings types in all districts:
  - a). At installation, the total LUMENS of all outdoor lighting may not exceed the LUMEN limits specified on Table 10.7.1 Permitted LUMENS.
- c. Color
  - i. All LUMINAIRES in all districts must have LIGHT SOURCES with a color temperature or correlated color temperature (CCT) of 3000 Kelvin or less.
  - ii. The color rendering index of all LUMINAIRES in all districts must be sixty-five (65) or higher.
- d. Light Fixtures
  - i. The following standards are applicable for all permitted BUILDING TYPES in the NR district and all permitted BUILDING TYPES, excluding Apartment Buildings, in the UR district:
    - a). All outdoor LUMINAIRES must be full cutoff or fully shielded to emit no light above horizontal (ninety degrees (90°) above nadir), with the following exceptions:
      - i). Up to two partly shielded or unshielded LUMINAIRES at any PRINCIPAL ENTRANCE.
      - ii). Low voltage lighting that does not project onto adjacent properties.
      - iii). Shielded directional flood lighting that is aimed so that direct glare is not visible from adjacent properties.
      - iv). Open flame gas LAMPS.
      - v). Lighting installed with a vacancy sensor, which extinguishes the lights no more than fifteen (15) minutes after the area is vacated.
    - b). Luminaries with the International Dark-Sky Association's Fixture Seal of Approval are recommended.
  - ii. The following standards are applicable to all other buildings types in all districts:
    - a). All LUMINAIRES must be rated and installed according to Table 10.7.2, which identifies the maximum backlight (B), uplight (U), and glare (G), as rated by the LUMINAIRE manufacturer, allowed in each zoning district.
    - b). BUG rating limits are based on the internal and external design of a LUMINAIRE, its aiming, and the initial LUMENS. The BUG ratings permitted by Table 10.7.2 differ based on the distance the LUMINAIRE is installed from the property line, in multiples of the MOUNTING HEIGHT of the LUMINAIRE.
    - c). LUMINAIRES equipped with adjustable mounting devices permitting alteration of LUMINAIRE aiming are prohibited.

# 10. DEVELOPMENT STANDARDS

## Outdoor Lighting

**Table 10.7.1 Permitted Lumens**

	NR	UR	MR3	MR4	MR5	MR6	HR	FAB
<b>Individual Luminaires</b>								
Unshielded Luminaires at Principal Entrances	630 LUMENS	630 LUMENS	--	--	--	--	--	--
Unshielded Luminaires, any other locations	315 LUMENS	315 LUMENS	--	--	--	--	--	--
Fully Shielded Luminaires	1,260 LUMENS	1,260 LUMENS	--	--	--	--	--	--
Landscape Lighting (total)	1,050 LUMENS	1,050 LUMENS	--	--	--	--	--	--
Landscape Lighting, Low Voltage (total)	525 LUMENS	525 LUMENS	--	--	--	--	--	--
Shielded Directional Flood Lighting	1,260 LUMENS	1,260 LUMENS	--	--	--	--	--	--
<b>Total Site Lumens <sup>1</sup></b>								
Lumens/sf Impervious Surface Area (per square foot of illuminated area)	2.50 LUMENS	2.50 LUMENS	2.50 LUMENS	2.50 LUMENS	5.00 LUMENS	5.00 LUMENS	5.00 LUMENS	5.00 LUMENS
Building Entrances/Exits (per door, installed within twenty (20) feet of the door)	+2,000 LUMENS	+2,000 LUMENS	+2,000 LUMENS	+2,000 LUMENS	+4,000 LUMENS	+4,000 LUMENS	+4,000 LUMENS	+4,000 LUMENS
Building Facades (per square foot of illuminated facade, for luminaries aimed at the facade)	+8/sf	+8/sf	+8/sf	+8/sf	+16/sf	+16/sf	+16/sf	+16/sf
Outdoor Cafes (per square foot of cafe area, within two (2) mounting heights of the luminaries)	+5/sf	+5/sf	+5/sf	+5/sf	+10/sf	+10/sf	+10/sf	+10/sf
Outdoor Displays (per square foot of outdoor sales area, within two (2) mounting heights of the luminaries)	+8/sf	+8/sf	+8/sf	+8/sf	+16/sf	+16/sf	+16/sf	+16/sf

<sup>1</sup> In the NR & UR districts, total site lumens is applicable only to Apartment Buildings and non conforming buildings

# 10. DEVELOPMENT STANDARDS

## Outdoor Lighting

**Table 10.7.1 Permitted Lumens**

	CC	CI	CB	CIV	ASQ	NP	PSR	TU
<b>Individual LUMINAIRES</b>								
Unshielded LUMINAIRES at PRINCIPAL ENTRANCES	--	--	--	--	--	--	--	--
Unshielded LUMINAIRES, any other locations	--	--	--	--	--	--	--	--
FULLY SHIELDED LUMINAIRES	--	--	--	--	--	--	--	--
Landscape Lighting	--	--	--	--	--	--	--	--
Landscape Lighting, Low Voltage (total)	--	--	--	--	--	--	--	--
Shielded Directional Flood Lighting	--	--	--	--	--	--	--	--
<b>Total SITE LUMENS <sup>1</sup></b>								
LUMENS/sf Impervious Surface Area (per square foot of illuminated area)	5.00 LUMENS	5.00 LUMENS	5.00 LUMENS	2.50 LUMENS	5.00 LUMENS	5.00 LUMENS	5.00 LUMENS	5.00 LUMENS
BUILDING Entrances/Exits (per door, installed within twenty (20) feet of the door)	+4,000 LUMENS	+4,000 LUMENS	+4,000 LUMENS	+2,000 LUMENS	+4,000 LUMENS	+4,000 LUMENS	+4,000 LUMENS	+4,000 LUMENS
BUILDING FACADES (per square foot of illuminated FACADE, for luminaries aimed at the FACADE)	+16/sf	+16/sf	+16/sf	+8/sf	+16/sf	+16/sf	+16/sf	+16/sf
Outdoor Cafes (per square foot of cafe area, within two (2) MOUNTING HEIGHTS of the luminaries)	+10/sf	+10/sf	+10/sf	+5/sf	+10/sf	+10/sf	+10/sf	+10/sf
OUTDOOR DISPLAYS (per square foot of outdoor sales area, within two (2) MOUNTING HEIGHTS of the luminaries)	+16/sf	+16/sf	+16/sf	+8/sf	+16/sf	+16/sf	+16/sf	+16/sf

<sup>1</sup> In the NR & UR districts, total SITE LUMENS is applicable only to Apartment Buildings and non conforming buildings



# 10. DEVELOPMENT STANDARDS

Outdoor Lighting

**Table 10.7.2 Maximum Backlight, Uplight and Glare (BUG) Ratings**

	NR	UR	MR3	MR4	MR5	MR6	HR	FAB	CC	CI	CB	CIV	ASQ	NP	PSR	TU
<b>Backlight <sup>1</sup></b>																
Greater than 2 MOUNTING HEIGHTS from property line.	B4	B4	B4	B4	B5	B5	B5	B5	B5	B5	B5	B5	B5	B5	B5	B5
One (1) to less than two (2) MOUNTING HEIGHTS from property line <sup>2</sup> and ideally oriented.	B3	B3	B3	B3	B4	B4	B4	B4	B4	B4	B4	B4	B4	B4	B4	B4
0.5 to 1 MOUNTING HEIGHTS from property line <sup>2</sup> and ideally oriented.	B3	B3	B3	B3	B3	B3	B3	B3	B3	B3	B3	B3	B3	B3	B3	B3
Less than 0.5 MOUNTING HEIGHT to property line <sup>2</sup> and ideally oriented.	B0	B0	B0	B0	B1	B1	B1	B1	B1	B1	B1	B1	B1	B1	B1	B1
<b>Uplight</b>																
Allowed uplighting rating	U2	U2	U2	U2	U3	U3	U3	U3	U3	U3	U3	U3	U3	U3	U3	U3
Allowed percentage light emission above 90 degrees for STREET or area lighting.	0%	0%	0%	0%	0%	0%	0%	0%	0%	0%	0%	0%	0%	0%	0%	0%
<b>Glare <sup>1</sup></b>																
Allowed Glare Rating	G2	G2	G2	G2	G3	G3	G3	G3	G3	G3	G3	G2	G3	G3	G3	G3
Any LUMINAIRE not ideally oriented with 1 to less than 2 MOUNTING HEIGHTS to any property line <sup>2</sup> of concern.	G1	G1	G1	G1	G1	G1	G1	G1	G1	G1	G1	G1	G1	G1	G1	G1
Any LUMINAIRE not ideally oriented with 0.5 to less than 1 MOUNTING HEIGHTS to any property line <sup>2</sup> of concern.	G0	G0	G0	G0	G1	G1	G1	G1	G1	G1	G1	G1	G1	G1	G1	G1
Any LUMINAIRE not ideally oriented with less than 0.5 MOUNTING HEIGHTS to any property line <sup>2</sup> of concern.	G0	G0	G0	G0	G0	G0	G0	G0	G0	G0	G0	G0	G0	G0	G0	G0

<sup>1</sup> An 'ideally oriented' LUMINAIRE must be mounted with its backlight portion of the light output oriented perpendicular and towards the property line of concern.

<sup>2</sup> An additional five (5) feet may be added to this calculation for any property line ABUTTING a CIVIC SPACE. Any property line ABUTTING a THOROUGHFARE may be considered to be located at the centerline of the THOROUGHFARE for the purpose of determining compliance with maximum BUG ratings.

# 10. DEVELOPMENT STANDARDS

## Screening

### 10.8 SCREENING

#### 1. Applicability

- a. Real property within the Commercial Industry district is exempt from the provision of this Section.

#### 2. Loading Facilities

- a. Outdoor loading facilities, including all docks and areas used for the storage and staging of materials must be screened from view by a wall or fully closed fence between six (6) and twelve (12) feet in height, as necessary to sufficiently screen delivery vehicles, and constructed of materials that are compatible with the PRINCIPAL BUILDING in terms of texture, quality, and color.
- b. Exterior entrances and ACCESS to loading facilities that are fully enclosed within a BUILDING must have an opaque, self closing door constructed of materials that are compatible with the PRINCIPAL BUILDING in terms of texture, quality, and color.
- c. Loading facility doors are only permitted to be opened during loading and unloading activities.

#### 3. Service Areas

- a. Trash collection, trash compaction, recycling collection and other similar service areas must be fully enclosed within a BUILDING or located to the side or rear of the buildings.
- b. Exterior entrances and ACCESS to service areas that are fully enclosed within a BUILDING must have an opaque, self closing door constructed of materials that are compatible with the PRINCIPAL BUILDING in terms of texture, quality, and color.
- c. Outdoor service areas that are visible from a public THOROUGHFARE (excluding an ALLEY), CIVIC SPACE, OR ABUTTING properties in the NR zoning district must be fully screened by a wall or fully closed fence at least six (6) feet in height with self-closing ACCESS doors and constructed of materials that are compatible with the PRINCIPAL BUILDING in terms of texture, quality, and color.

#### 4. Mechanical Equipment

- a. Roof-Mounted
  - i. Mechanical equipment, except roof-mounted sustainable energy systems, and elevator/stairwell penthouses must be set back at least ten (10) feet from the edge of the exterior wall of a BUILDING.
  - ii. New buildings must provide a parapet wall or other architectural element constructed of materials that are compatible with the PRINCIPAL BUILDING in terms of texture, quality, and color that screens the visibility of roof-mounted mechanical equipment from any a public THOROUGHFARE (excluding an ALLEY) OR CIVIC SPACE.
- b. Wall-Mounted
  - i. Mechanical equipment is not permitted on any FACADE.
  - ii. Mechanical equipment on any surface that is visible from a public THOROUGHFARE (excluding an ALLEY) OR CIVIC SPACE must be screened by landscaping or an opaque screen constructed of materials that are compatible with the PRINCIPAL BUILDING in terms of texture, quality, and color.
- c. Ground-Mounted
  - i. Mechanical equipment that is visible from a public THOROUGHFARE (excluding an ALLEY) OR CIVIC SPACE must be screened by landscaping, a fence, or a wall constructed of materials that are compatible with the PRINCIPAL BUILDING in terms of texture, quality, and color.
  - ii. Screening must be of a height equal to or greater than the height of the mechanical equipment being screened.

## 10.9 COMMERCIAL SIGNS

### 1. Purpose

- a. To provide PROPERTY OWNERS and tenants reasonable and effective means for identifying STREET address, business name, goods sold or produced, and services provided to the public.
- b. To regulate the size, location, and physical design of temporary and permanent SIGNS.
- c. To preserve the cultural SIGNificance of architectural resources for the enjoyment and enrichment of the community.
- d. To protect against the adverse impacts of visual clutter and excessive and/or confusing SIGNS.
- e. To promote legibility of the urban environment.

### 2. Applicability

- a. Nothing contained in this Section is intended to be the content-based regulation of SIGN messages prohibited by the federal or state constitution, statutes, or COURT decisions.
- b. Nothing contained in this Section is intended to conflict with M.G.L. Chapter 85, Section 8 & 9 or M.G.L. Chapter 93, Sections 29 through 33, as amended.

### 3. Development Review

- a. General
  - i. The following commercial SIGN types are permitted by Site Plan Approval:
    - a). Blade SIGN
    - b). Wall SIGN
    - c). Awning or Canopy SIGN
    - d). Suspended SIGN
    - e). Sidewalk SIGN
    - f). Window SIGN
    - g). Display Case
    - h). Vertical Blade or Banner SIGN
    - i). Yard SIGN
    - j). Wall Mural
    - k). Roof or Skyline SIGN
  - ii. SIGNS types not identified in this Section are prohibited.

### 4. Address Signs

- a. A SIGN, individual numerals or letters, or a nonelectrical nameplate identifying the property address is required for all real property as follows:
  - i. Each ground STORY non-residential USE must identify the STREET address either on the PRINCIPAL ENTRANCE door or above or beside the PRINCIPAL ENTRANCE of the USE.
  - ii. All residential BUILDING TYPES must identify the STREET address either on the PRINCIPAL ENTRANCE door, above or beside the PRINCIPAL ENTRANCE, or on a mailbox.

- b. Address SIGNS must be made easily visible through the USE of colors or materials that contrast with the background material they are attached to and must be conspicuously located to provide visibility from the THOROUGHFARE that the BUILDING faces.
- c. Address SIGNS must be twelve (12) inches in height or less and may include the name of the occupant.

### 5. Exempt Signs

- a. The following SIGNS are exempt from regulation under this Section:
  - i. A public notice or informational SIGN required by federal, state, or local law, regulation, or ordinance and any special event, directional, or other SIGN ERECTED by a government agency or public utility in the performance of public duty;
  - ii. Names of buildings, dates of ERECTION, commemorative tablets and the like when carved into stone, made of cast metal, or other permanent type of material;
  - iii. Credit card, trading stamp, or trade association SIGNS not exceeding one-half (0.5) square feet each and not exceeding ten per establishment;
  - iv. A clock, thermometer, barbershop pole or similar device not part of a permanent SIGN;
  - v. The flag of any nation, state, or City if displayed in a manner conforming to the Flag Code (4 USC §5 (2011) et seq.);
  - vi. Historic BUILDING identification;
  - vii. Holiday SIGNS or decorations, yard sale & garage sale SIGNS;
  - viii. Political yard SIGNS; and
  - ix. Any sculpture, statue, relief, mosaic, or mural that is a work of art or otherwise decorative and does not include a commercial message or symbol.

### 6. Prohibited Signs

- a. The following SIGNS are prohibited:
  - i. Any SIGN that flashes, moves, blinks, rotates, simulates motion, features electronic SIGN copy, or has illumination that changes intensity over time;
  - ii. SIGNS that emit audible sounds, odors, or visible matter;
  - iii. SIGNS attached to nature or landscape elements, including trees, rocks, and fences;
  - iv. The tacking, posting or otherwise affixing of SIGNS to the exterior walls of buildings and STRUCTURES;
  - v. SIGNS that interfere with free passage from or obstructs any fire escape, downspout, window, door, stairways, ladder, or opening intended as a means of ingress or egress or to provide light or air;

# 10. DEVELOPMENT STANDARDS

## Commercial Signs

- vi. Billboards or SIGNS advertising goods or services not provided on the premises;
- vii. Any SIGN and/or SIGN STRUCTURE that obstructs the view of, is confusing with, or imitates official traffic SIGN, SIGNAL, or device;
- viii. Inflatable SIGNS, such as balloons and other gas inflated objects;
- ix. SIGN STRUCTURES that no longer contain SIGNS;
- x. SIGNS mounted to motor-vehicles that are not in operation, including motor-vehicles painted or skinned to function as a SIGN; and
- xi. Outdoor advertising SIGNS that are not compliant with M.G.L. Chapter 93, Section 29-33.

### 7. Temporary Signs

- a. Unless otherwise specified, temporary SIGNS are permitted for a maximum of thirty (30) total days, subject to the following standards:
  - i. Banner: A temporary SIGN that is printed or displayed upon flexible material with or without frames, that identifies a new business or advertises a special sale, event, or activity.
    - a). One (1) banner SIGN no greater than forty (40) square feet is permitted per LOT frontage.
    - b). Banners must be secured to a BUILDING FACADE along all four sides at all times.
  - ii. Construction SIGN: A temporary SIGN intended to provide information about current construction on a SITE and the parties involved in the project.
    - a). One (1) construction SIGN no greater than twelve (12) square feet per side is permitted per DEVELOPMENT SITE.
    - b). A construction SIGN may be ERECTED only after issuance of a BUILDING Permit, and must be removed within two (2) days of issuance of a certificate of occupancy.
  - iii. Real Estate SIGN:
    - a). One (1) real estate SIGN no greater than twelve (12) square feet is permitted per LOT frontage.
    - b). A real estate SIGN that advertises property for lease or sale may be posted only for the duration the property is offered for lease or sale, and must be removed within seven days of lease or closing.

### 8. Sign Maintenance

- a. All SIGNS, including nonconforming SIGNS, together with any supports, braces, anchors, and other supporting hardware, must be maintained in good condition. Any damage to or deterioration of a SIGN must be repaired within 30 days of receipt of notice from the BUILDING OFFICIAL.
- b. When an existing SIGN is removed, replaced, or repaired, all supports, braces, anchors, and other

supporting hardware that is not longer required must be removed, and any surfaces baring evidence of attachment must be repaired.

### 9. Removal

- a. SIGNS must be removed within thirty (30) days of a USER vacating a property.

### 10. Sign Illumination

- a. Conforming SIGNS may be illuminated according to the following:
  - i. General
    - a). Illuminated SIGNS indicating if a business is open must be turned off except during the hours of operation.
  - ii. External Illumination
    - a). An externally illuminated SIGN is characterized by the USE of artificial light reflected off the surface of a SIGN.
    - b). External LIGHT SOURCES must be shielded so that they illuminate only the face of the SIGN and do not shine directly onto a public right-of-way or onto adjacent properties.
    - c). Light fixtures that project from the FACADE of a BUILDING for externally illuminated SIGNS are exempt from SETBACK requirements, but should be simple and unobtrusive in design and not obscure the SIGN content.
  - iii. Internal Illumination
    - a). An internally illuminated SIGN is characterized by the USE of artificial light projecting through or from behind the surface of a SIGN.
    - b). Channel letters may be internally lit or back-lit.
    - c). Blade SIGNS may be internally lit if the background is opaque or of a darker color than the message of the SIGN and the lettering is no more than 50% of the surface area of the SIGN
    - d). Exposed neon is only permitted for wall or windows SIGNS.
  - iv. Raceways
    - a). If a raceway is necessary, it cannot extend in width or height beyond the area of the SIGN.
    - b). A raceway must be finished to match the background wall or canopy or integrated into the overall design of the SIGN.

## 11. Blade Sign

- a. A small, two-sided SIGN that is attached to and projecting perpendicularly from the FACADE of a BUILDING that identifies a commercial establishment. Blade SIGNS are intended to be viewed by pedestrians on the same side of the STREET.

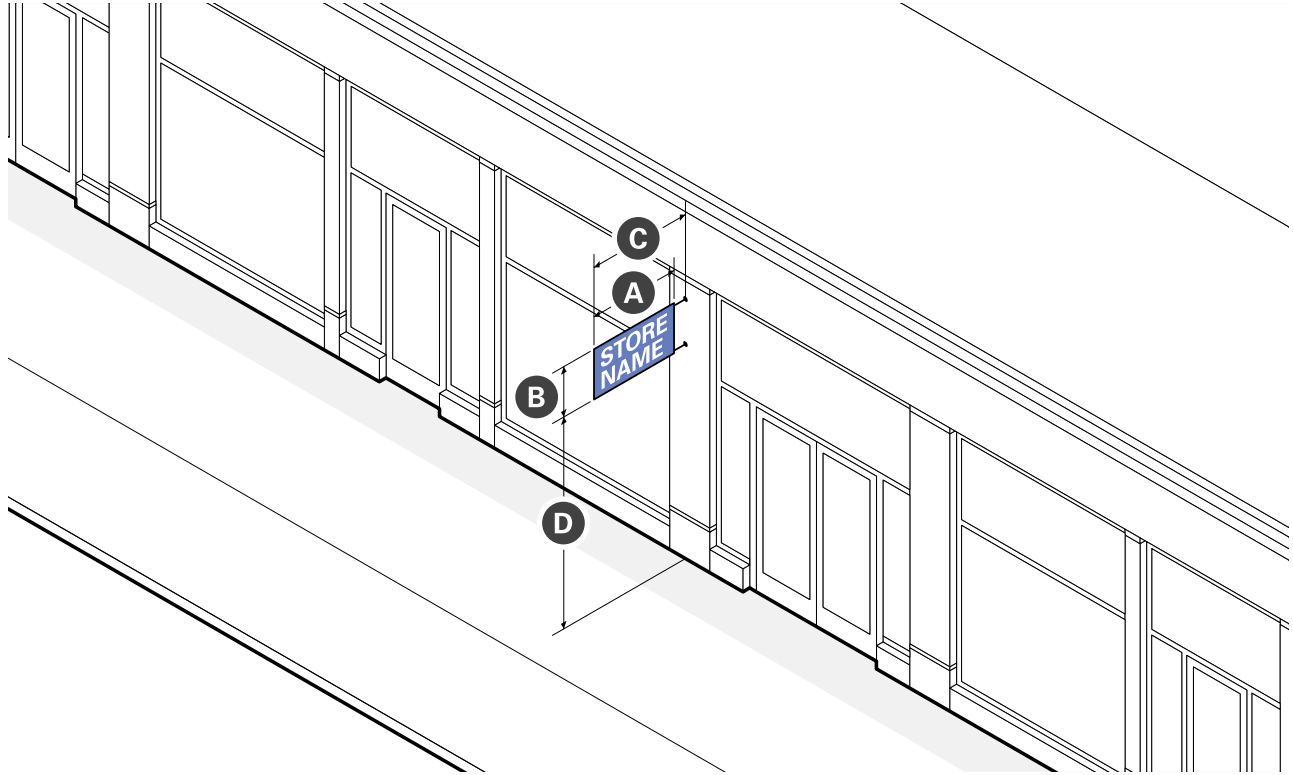

Size	
Area (max.)	6 sq. ft. / side
Width (max.)	4 ft
Height (max.)	3 ft
Thickness (max.)	6 inches

Location	
Clear Height over Sidewalk (min.)	8 ft
Projection from FACADE (max.)	4 ft
Number of SIGNS	1 per Tenant

- b. Standards
- i. Blade SIGNS are prohibited for UPPER STORY businesses.
  - ii. A blade SIGN must be located within ten (10) feet of the PRINCIPAL ENTRANCE for the business it identifies.
  - iii. A blade SIGN, including any support hardware, must be mounted below the sills of the second STORY windows of multi-STORY buildings or below the ROOF LINE, parapet wall, or CORNICE of a single-STORY BUILDING.
  - iv. Any supports, braces, anchors, and other supporting hardware must be integral to the design of the SIGN.
  - v. Information type is limited to business name and logo. Additional information is prohibited.

# 10. DEVELOPMENT STANDARDS

## Commercial Signs

### 12. Wall Sign

- a. A SIGN attached flat or mounted parallel to the FACADE of a BUILDING that identifies a commercial establishment. Wall SIGNS are intended to be viewed by pedestrians on the OPPOSITE side of STREET.

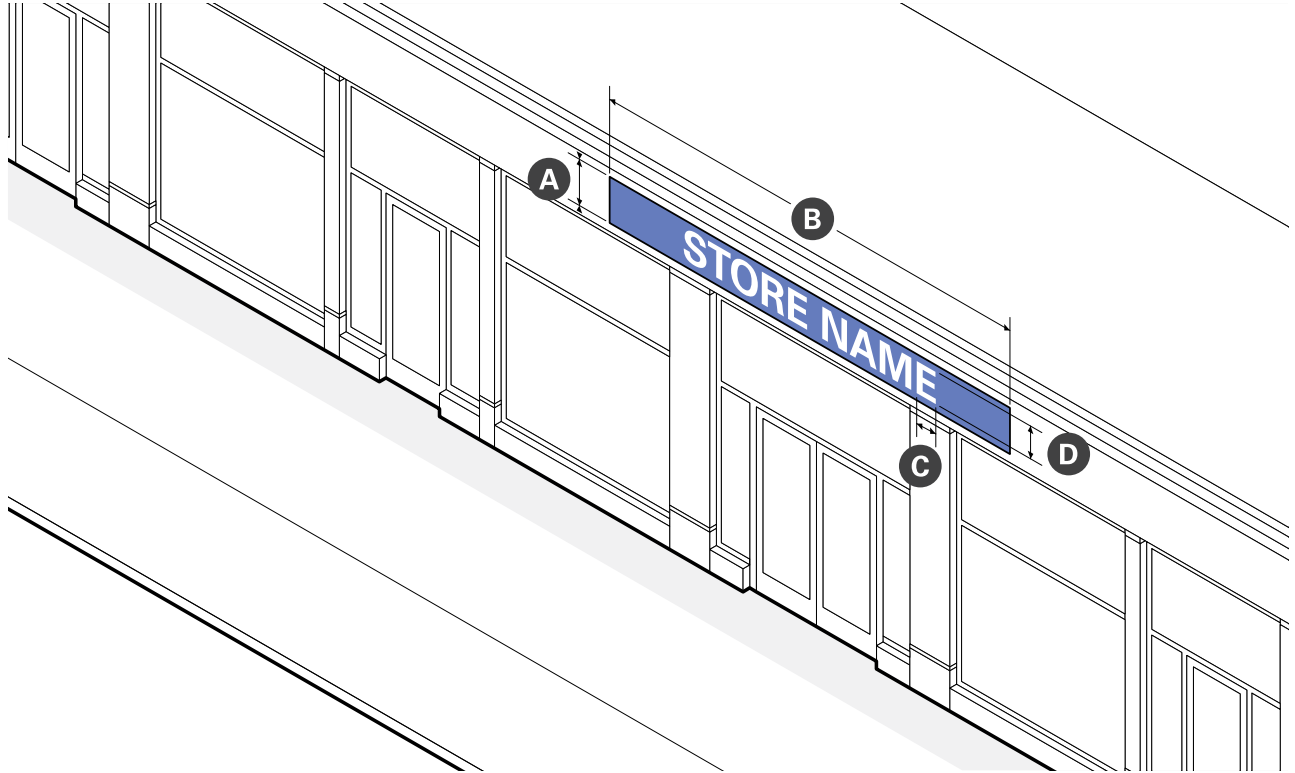

Size	
Area (max.)	40 sq. ft.
Height (min/max)	1 ft 4 ft
Width (max.)	90% of FACADE width

Lettering	
Width (max.)	75% of SIGN width
Height (max.)	75% of SIGN height
Projection from FACADE (max.)	6 inches
Raceway Height (max.)	50% of Letter Height

Location	
Number of SIGNS	1 per Tenant (2 per Corner Tenant)

- b. Standards
- i. Wall SIGNS are only permitted for GROUND STORY businesses.
  - ii. Internally illuminated SIGN cabinets are prohibited.
  - iii. Wall SIGNS are prohibited from covering windows or architectural details.
  - iv. No portion of a wall SIGN is permitted to extend above the lower eave line of a BUILDING with a pitched roof.
  - v. No portion of a wall SIGN is permitted to extend above the ROOF LINE or parapet wall of a FLAT ROOFED BUILDING.
  - vi. No portion of a wall SIGN is permitted to extend above the CORNICE or expression line of the base of a BUILDING.
  - vii. Information type is limited to business name and logo. Additional information is prohibited.



**13. Awning or Canopy Sign**

a. A SIGN that is painted, screen printed, sewn, or adhered onto the surface of an awning or attached above, below, or to the face of an entry canopy that identifies a commercial establishment. Awning/canopy signs are intended to be viewed by pedestrians on the opposite side of STREET.

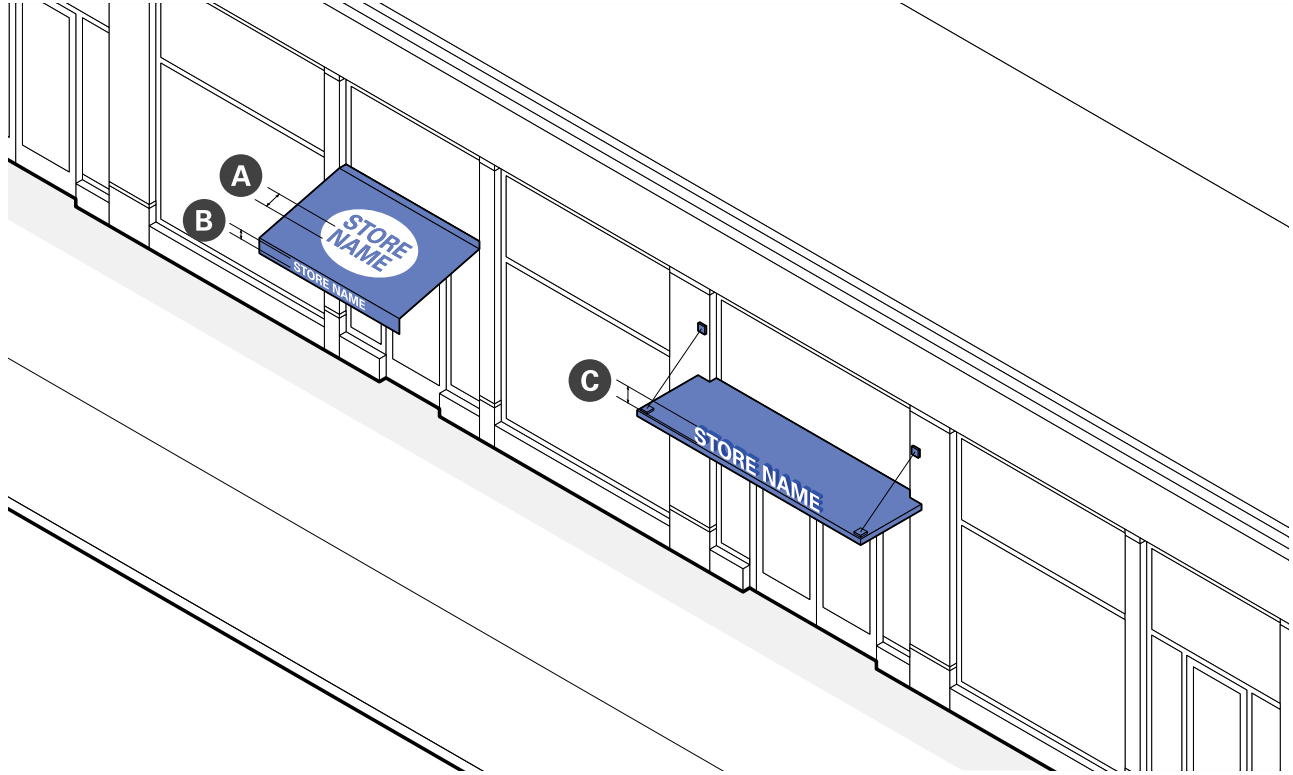

Size	
Area	--
Located on Valance (max.)	50% coverage
Located on Awning Slope (max.)	25% coverage
Projecting from Canopy (max.)	1 sf. per width of canopy

Lettering	
Height	--
Valance (max)	8 in
Awning Slope (max)	18 in
Projecting from Canopy (max)	12 in

Location	
Number of SIGNS per Awning	1
Number of SIGNS per Canopy	1

b. Standards

- i. SIGNS are not permitted on awnings or canopies that do not conform to the provisions for each type of BUILDING component. See §3.D. BUILDING COMPONENTS for more information.
- ii. SIGNAGE located on the sloping portion of an awning is only permitted for storefronts where the typical area for a wall SIGN is missing.
- iii. SIGNAGE is prohibited on UPPER STORY awnings and on the side of awnings with closed ends.
- iv. Information type is limited to business name, logo, and address. Additional information is prohibited.

# 10. DEVELOPMENT STANDARDS

## Commercial Signs

### 14. Suspended Sign

- a. A small, two-sided SIGN mounted to the underside of an awning, canopy, or roof of a porch that identifies a commercial establishment. Suspended SIGNS are intended to be viewed by pedestrians at close range on the same side of the STREET.

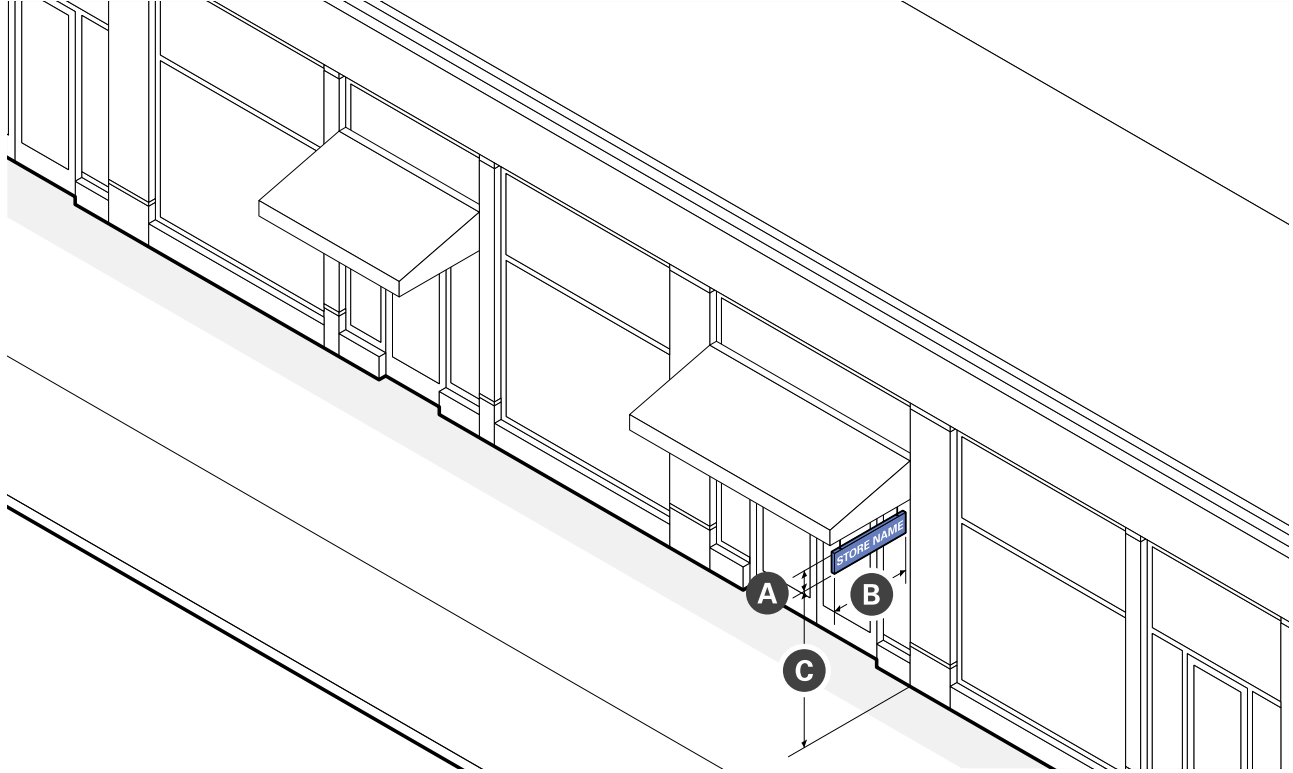

Size	
Area (max.)	4 sq. ft. / side
Width (max.)	3 feet
Height (max.)	3 feet

Location	
Clear Height over Sidewalk/Porch (min.)	7 feet
Number of SIGNS	1 per Tenant

- b. Standards
  - i. A suspended SIGN may not extend beyond the edge of the awning or canopy it is mounted below.
  - ii. Information type is limited to business name or logo. Additional information is prohibited.

**15. Sidewalk Sign**

a. A portable, two-sided sign that is placed on the sidewalk to identify a commercial establishment or advertise daily specials or sales. Sidewalk signs are intended to be viewed at close range by pedestrians on the same side of the STREET.

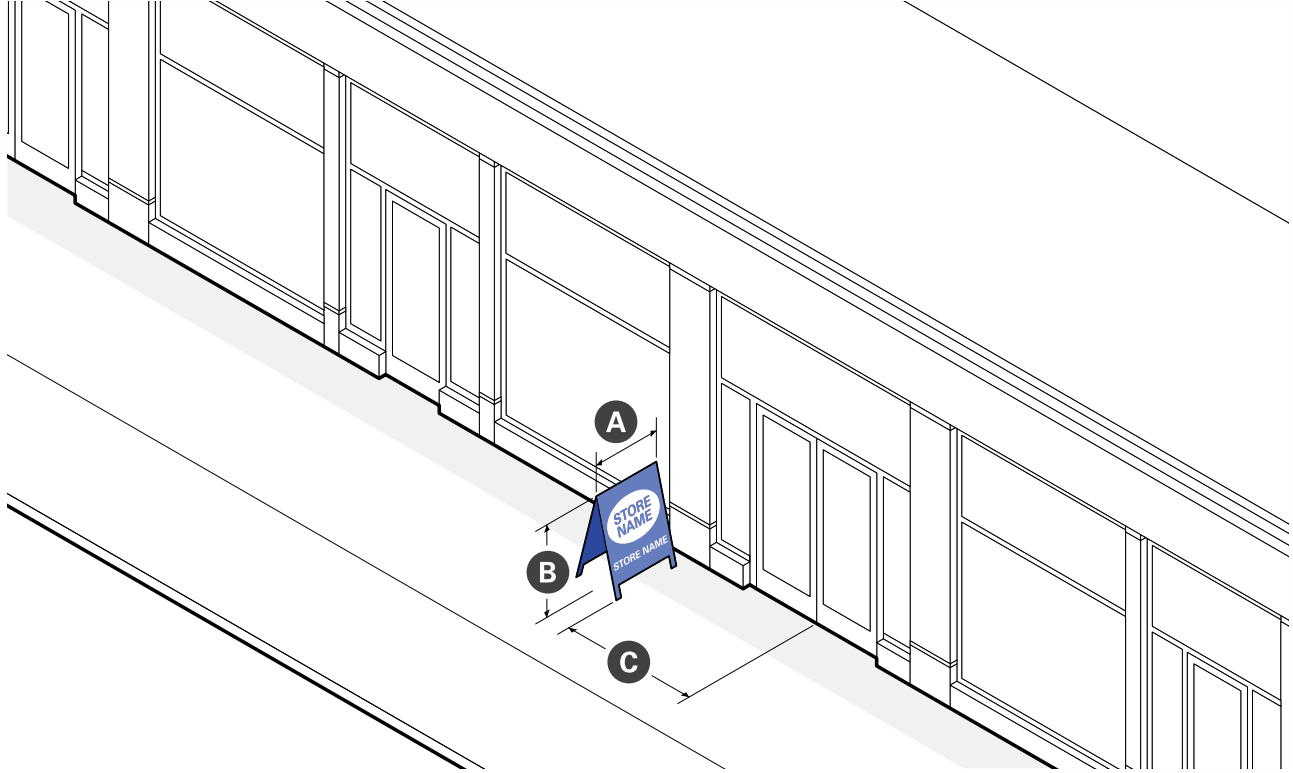

Size	
Area (max.)	6 sq. ft. / side
Width (max.)	2 feet
Height (max.)	3 feet

Location	
Distance from PRINCIPAL ENTRANCE (max.)	8 feet
Number of SIGNS	1 per Tenant

b. Standards

- i. One (1) Sidewalk sign is permitted per GROUND STORY tenant.
- ii. Sidewalk signs may be placed outdoors on site or on a public sidewalk during business hours and must be removed when the business is closed.
- iii. Sidewalk signs displayed on a public sidewalk are prohibited from ENCROACHING into the walkway of the sidewalk or interfering with pedestrian travel in any way.
- iv. A sidewalk sign must be vertically oriented, with a height greater than its width and made of wood, metal, or slate (chalkboard).
- v. A sidewalk sign is not permitted to be illuminated or contain any electronic components.
- vi. A sidewalk sign may not be placed outdoors when high winds, heavy rain, or heavy snow conditions are present. The Department Public Works may remove a sidewalk sign during snow removal operations, and is not liable for damage to a sidewalk sign caused by snow removal operations.

# 10. DEVELOPMENT STANDARDS

## Commercial Signs

### 16. Window Sign

- a. Individual letters, numerals, or a logo applied directly to the inside of a window or door to identify a commercial establishment. Window SIGNS are intended to be viewed at close range by pedestrians.

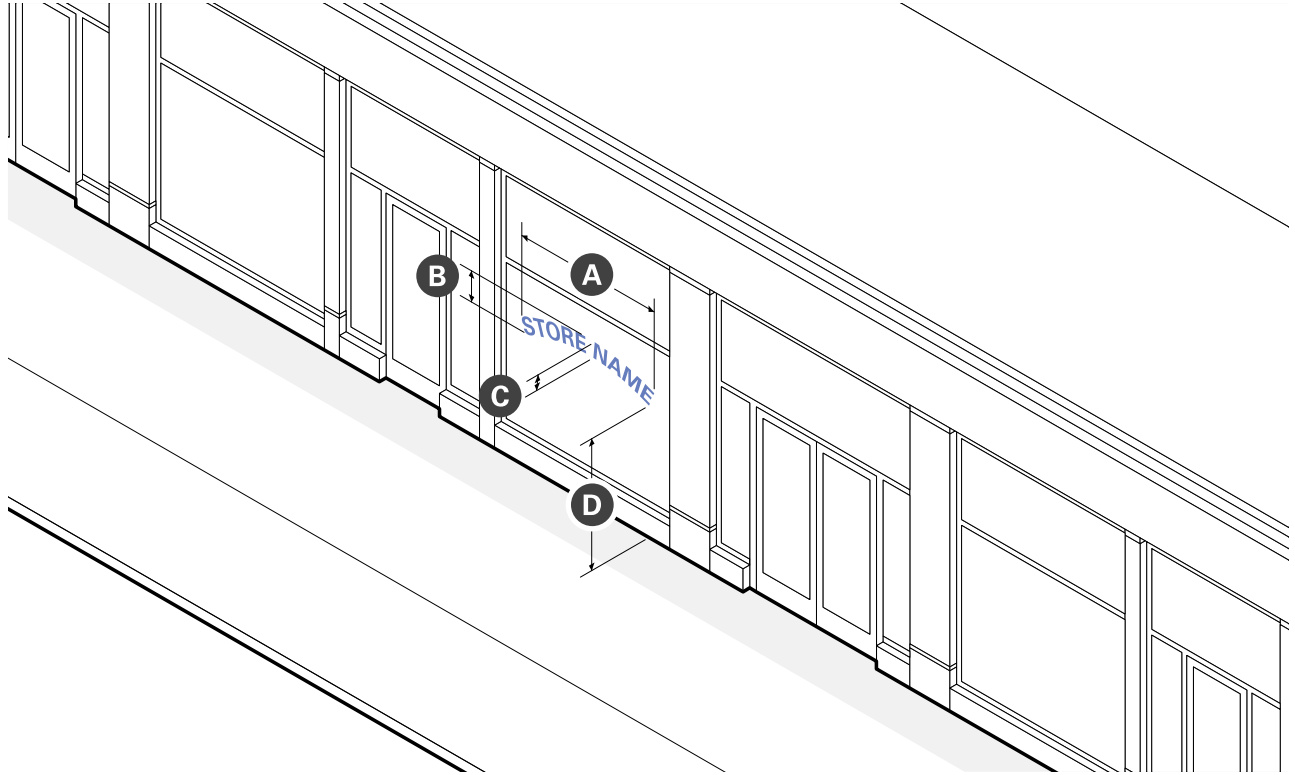

Size	
Area (max. of total window glass)	20%
Width (max.)	5 feet
Height (max.)	3 feet

Lettering	
Height (max.)	18 inches

Location	
Height above Sidewalk (min.)	5 feet
Number of SIGNS	1 per Window

- b. Standards
  - i. Windows SIGNS must be applied directly to inside of the windows glass, at or above eye level, and have a transparent background.
  - ii. Information type is limited to business name, logo, hours of operations, and product types. Additional information is prohibited.

**17. Display Case**

- a. A wall mounted, lockable, framed cabinet with a transparent window to display a changeable menu or list of event show times. Display cases are intended to be viewed at close range by pedestrians.

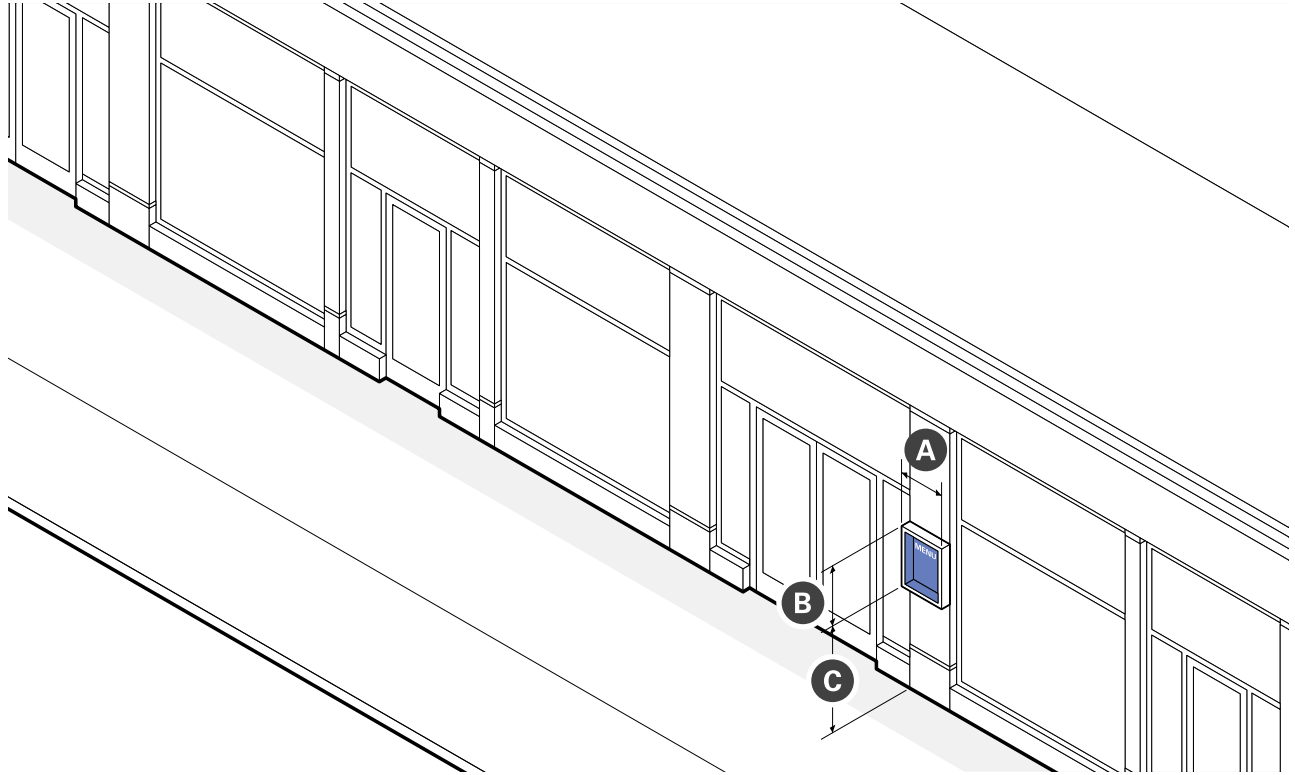

Size	
Area	6 sq. ft.
Width (max.)	3 feet
Height (max.)	3 feet

Location	
Height above Sidewalk (min.)	4 feet
Number of SIGNS	1 per Tenant

- b. Standards
- i. Display cases must be attached to the FACADE or wall of a recessed storefront entrance.
  - ii. Display cases may be internally or externally illuminated.

# 10. DEVELOPMENT STANDARDS

## Commercial Signs

### 18. Vertical Blade / Banner Sign

a. A tall, narrow, two-sided SIGN that is attached to and projecting perpendicularly from the FACADE of a BUILDING that identifies a commercial establishment. Vertical blade/ banner SIGNS are intended to be viewed by pedestrians and motorists from a distance.

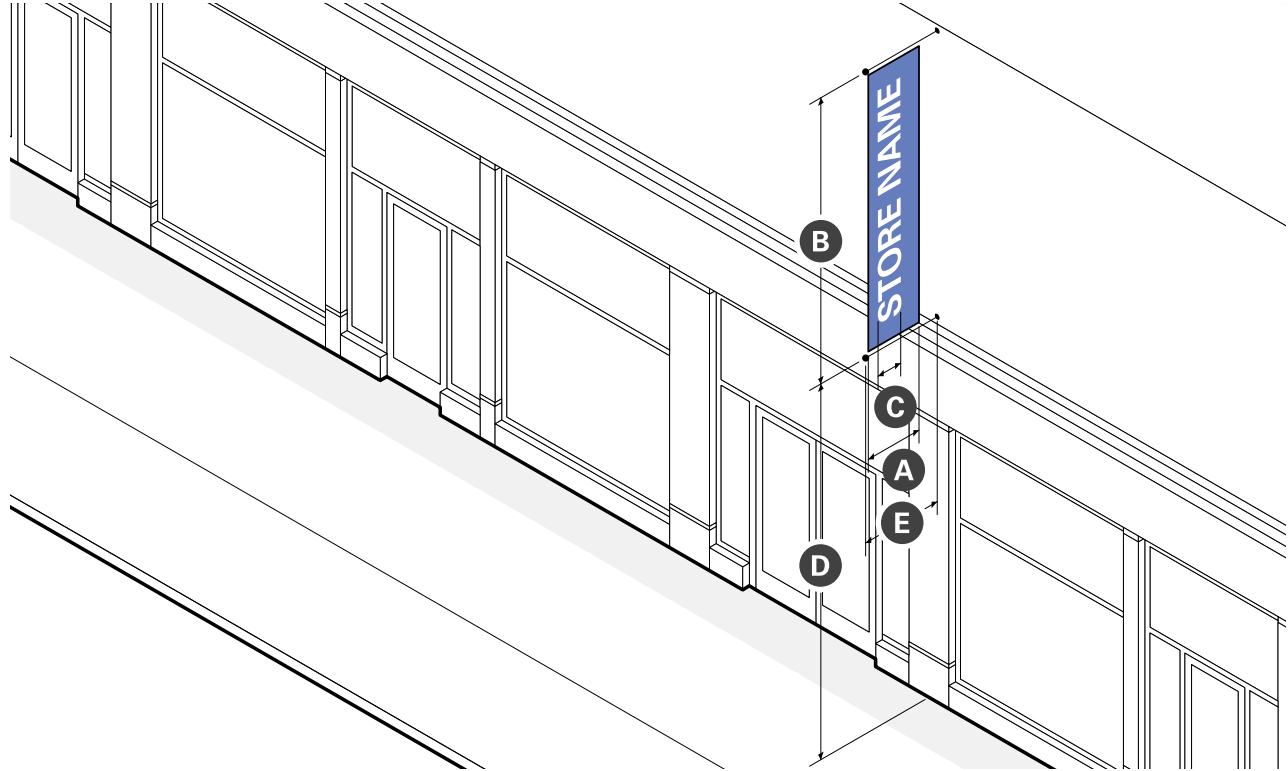

Size	
Width (max.)	4 feet
Height (max.)	10 feet
Thickness (max.)	10 inches

Lettering	
Width	75% of SIGN Width

Location	
Clear Height over Sidewalk (min.)	above 1 <sup>ST</sup> STORY
Projection from FACADE (max.)	6 feet
Number of SIGNS	1 per 15 feet of FACADE Width (4 max.)

b. Standards

- i. No portion of the SIGN may project above the roof-line of the FACADE to which it is attached.
- ii. Information type is limited to business name and logo. Additional information is prohibited.



**19. Yard Sign**

- a. A two-sided SIGN suspended from support hardware and mounted in a front yard between the FRONT LOT LINE and the BUILDING FACADE. Yard SIGNS are intended to be viewed at close range by pedestrians on the same side of the STREET and motorists.

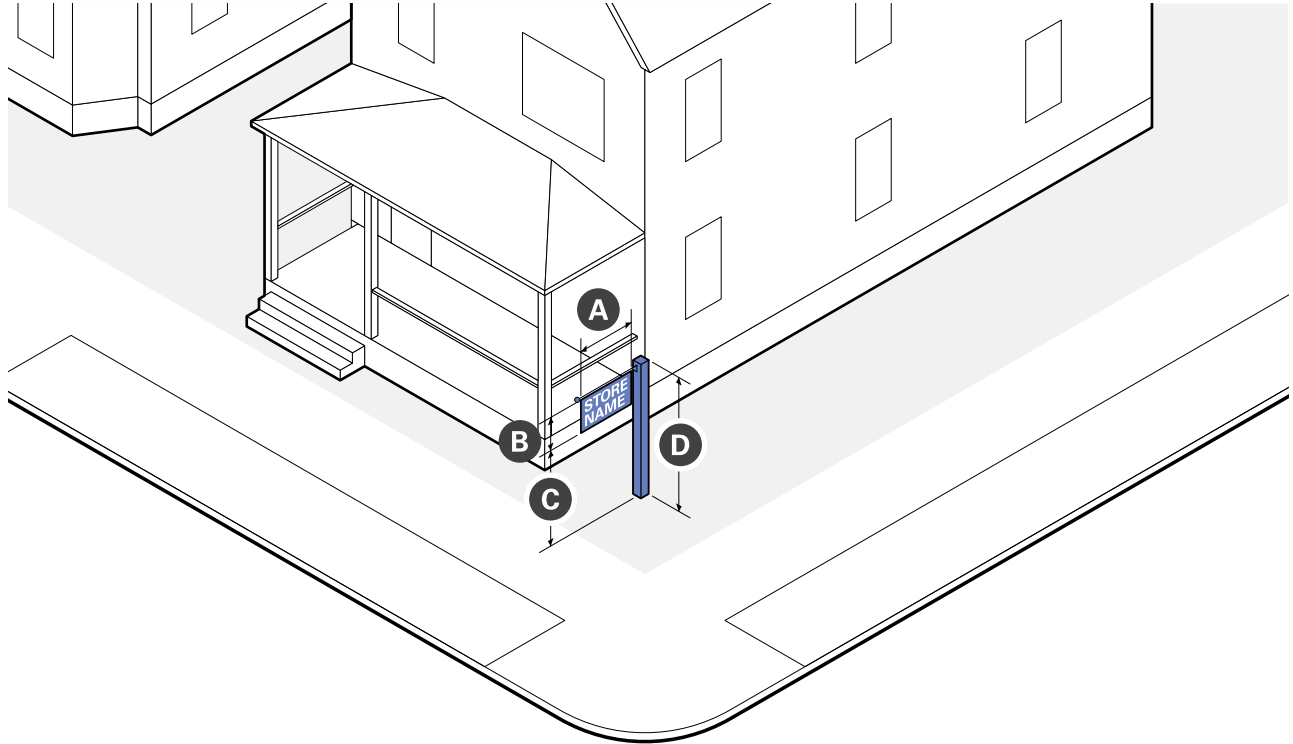

Size	
Area (max.)	6 sq. ft. / side
Width (max.)	3 feet
Height (max.)	3 feet

Location	
Clear Height above Yard (min.)	12 inches
Overall Height (max.)	5 feet
Number of SIGNS	1 per Lot

- b. Standards
- i. Yard SIGNS work well for home based or commercial businesses operating in residential BUILDING TYPES in mixed USE districts.
  - ii. Information type is limited to business name, logo, and address. Additional information is prohibited.

# 10. DEVELOPMENT STANDARDS

## Commercial Signs

### 20. Wall Mural

- a. A SIGN that is directly painted on to the exterior wall of a BUILDING or screen printed, sewn, or adhered onto a canvas-like material that is mounted flush with the FACADE of a BUILDING that identifies a commercial establishment. Wall murals are intended to be viewed by pedestrians and motor vehicles from a distance.

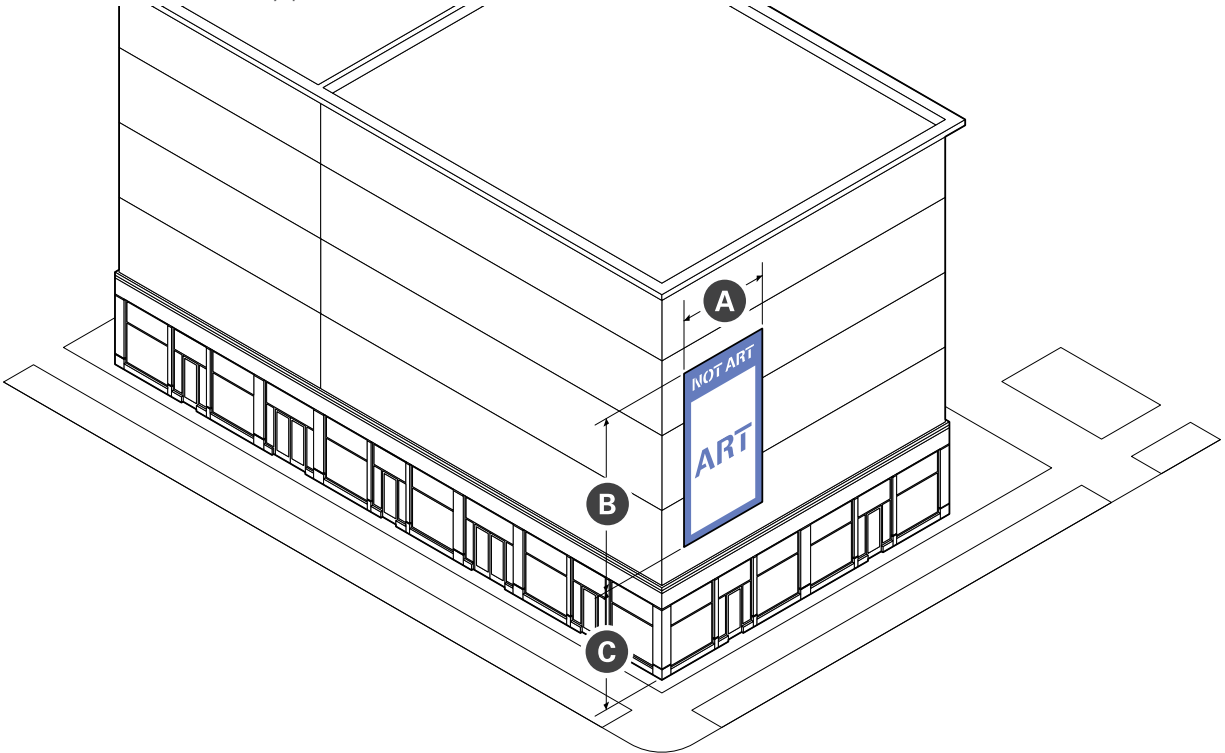

Size	
Area (max.)	1,000 sq. ft.
Width (max.)	50 feet
Height (max.)	50 feet

Location	
Height above Ground (min.)	1 STORY
Number of SIGNS	1 per BUILDING

- b. Standards
  - i. Lettering or logos must be limited to no more than twenty percent (20%) of the surface area of the wall mural.
  - ii. Only external illumination is permitted.

### 21. Roof or Skyline Sign

- a. A SIGN ERECTED on the roof or mounted to the uppermost horizontal architectural band of a BUILDING to identify the name of the BUILDING or primary tenant. Roof/skyline SIGNS are intended to be viewed by pedestrians and motorists from a distance and serve as an icon for the BUILDING.

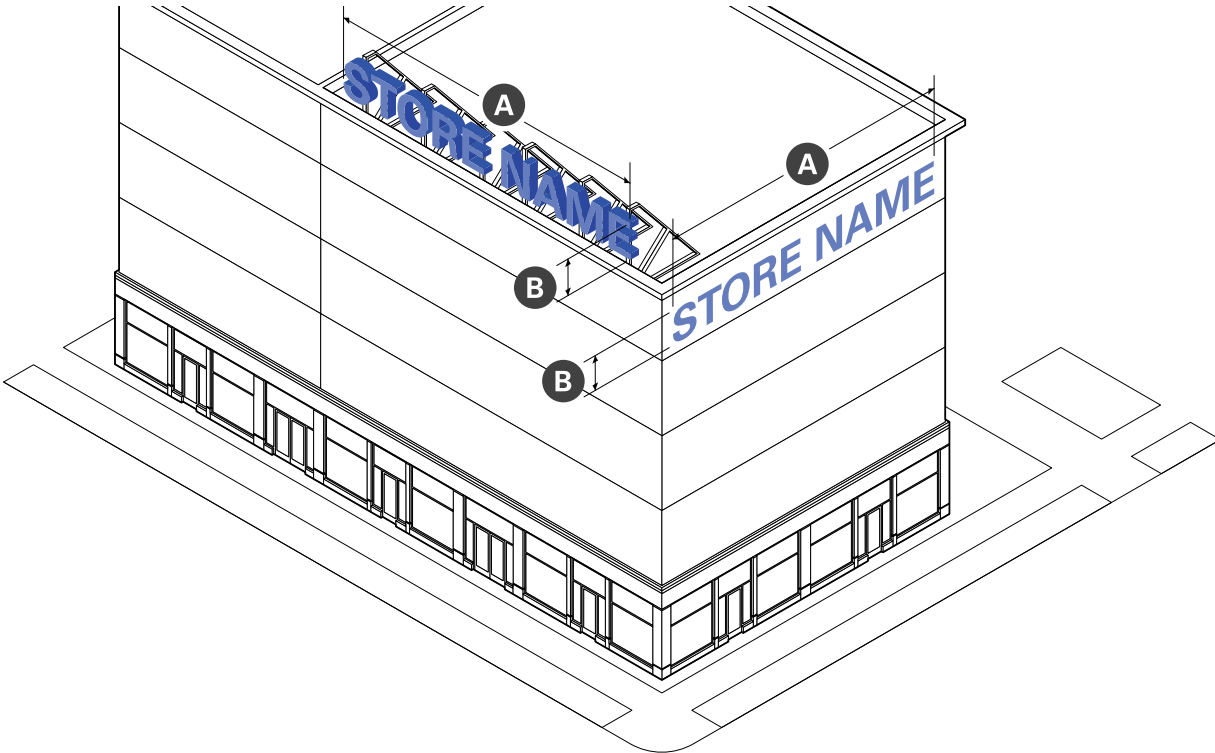

Size	
Area (max.)	250 sq. ft.
Width (max. % of FACADE width)	75%
Height (max.)	15 feet
Raceway Height (max.)	50% of Letter Height

Location	
Number of SIGNS	1 per BUILDING

### b. Standards

- i. Roof/skyline SIGNS are only permitted on HIGH-RISE buildings.
- ii. No portion of a roof/skyline SIGN is permitted to extend below the start of highest STORY of a BUILDING or above the ROOF LINE, parapet wall, or CORNICE of the top portion of a FACADE and is prohibited from covering windows or architectural details.
- iii. Only internal illumination is permitted.
- iv. Information type is limited to BUILDING or primary tenant name. Additional information is prohibited.

# 10. DEVELOPMENT STANDARDS

## Steep Slopes

### 10.10 STEEP SLOPES

#### 1. Intent

- a. To minimize storm water runoff and soil erosion problems incurred by the grading of STEEP SLOPES.
- b. To maintain the natural topography and drainage patterns of land.
- c. To help protect real property at the base of a STEEP SLOPE from damage caused by erosion, mudslides, rock slides, falling trees, and other harms.

#### 2. Purpose

- a. To require discretion in the permitting of DEVELOPMENT on any property with a STEEP SLOPE.

#### 3. Applicability

- a. This section is applicable to real property in all zoning districts.

#### 4. Development Review

- a. DEVELOPMENT on any LOT with a STEEP SLOPE requires a special permit, except for the following:
  - i. MODIFICATIONS to a BUILDING TYPE that do not increase the cumulative FLOOR PLATE (main mass plus components) by more than two-hundred and fifty (250) square feet, as identified by Building Permit records maintained by the Inspectional Services Department of the City of Somerville, within any twelve (12) month period.
  - ii. SITE improvements, excluding excavation, to any LOT that do not exceed five hundred (500) square feet, as identified by Building Permit records maintained by the Inspectional Services Department of the City of Somerville, within any twelve (12) month period.
- b. In addition to the review criteria for all Special Permits specified in §15.2.1.e. Review Criteria, the review board shall make findings considering the following in its discretion to approve or deny a special permit authorizing DEVELOPMENT ON ANY LOT WITH A STEEP SLOPE:
  - i. Consistency of SITE disturbance with the intent and purpose of this Section.
  - ii. Geo-technical, structural engineering, and ARBOREAL best practices for successfully and safely stabilizing STEEP SLOPES.

**10.11 SUSTAINABLE DEVELOPMENT**

**1. Applicability**

- a. Real property within the Fabrication district or Commercial Industry district is exempt from the provisions of this Section.

**2. Green Buildings**

- a. New construction or MODIFICATIONS greater than twenty five thousand (25,000) square feet of GROSS FLOOR AREA must be LEED Silver certifiable.
- b. New construction or MODIFICATIONS greater than fifty thousand (50,000) square feet of GROSS FLOOR AREA must be LEED Gold certifiable.
- c. DEVELOPMENT subject to the provisions of this Section must meet the standards of the most current LEED BUILDING rating system. During the twelve (12) month time period after the adoption of a new version of LEED, permit applications may be submitted demonstrating compliance to either the immediately previous or newly adopted version of the LEED BUILDING rating system.
- d. Development review applications for DEVELOPMENT subject to the provisions of this Section must include:
  - i. A completed LEED checklist for the appropriate LEED BUILDING standard to demonstrate how the proposed DEVELOPMENT is anticipated to meet the standards of this Section.
  - ii. A narrative indicating the mechanisms proposed to achieve each of the credits and prerequisites of the appropriate LEED BUILDING standard and demonstrating the anticipated methods by which compliance with the requirements of this Section will be achieved at the time of construction.
  - iii. An affidavit by a LEED-Accredited Professional (LEED-AP) Project Manager or by appropriate consultants stating that to the best of their knowledge, the project has been designed to achieve the stated LEED BUILDING standard.
- e. Prior to the issuance of the first BUILDING Permit and prior to the issuance of the first Certificate of Occupancy, the LEED checklist and narrative description outlining compliance with the certification level required by this Section must be updated to identify any design changes made subsequent to Site Plan Approval and submitted to the BUILDING OFFICIAL accompanied by an affidavit by a LEED-AP Project Manager or appropriate consultants stating that, to the best of their knowledge, the project has been designed to achieve the stated LEED BUILDING standard.

**3. Green Roofs & Storm Water Management**

- a. To every extent practicable, storm water should be REUSED ON-SITE for irrigation or other purposes.

- b. The review boards may authorize the City Engineer to grant a credit to properties, against which any storm water impact fees are imposed, equivalent to the quantity of storm water that is removed from entering the system through the USE of green roofs or other ON-SITE storm water management practices.

**4. Heat Island Reduction**

- a. Roofs and parking covers must have a SOLAR REFLECTANCE INDEX as specified on Table 10.11.1 for a minimum of seventy five percent (75%) of the roof area or parking spaces.
  - i. Roof area and parking spaces covered by solar collectors and green roofs compliant with the provisions of this Ordinance are exempt.
- b. Uncovered SURFACE PARKING spaces must have a minimum initial SOLAR REFLECTANCE of 0.33 or three (3) year aged SOLAR REFLECTANCE of 0.28.

**Table 10.11.1 Required SOLAR REFLECTANCE INDEX**

	Initial SRI	3 year aged SRI
FLAT ROOFS and roofs pitched at or below nine and one-half degrees (9.5°; 2:12)	82	64
Roofs pitched above nine and one-half degrees (9.5°; 2:12)	39	32
Parking Cover	39	32

**5. Environmental Performance**

- a. The review boards shall establish submittal requirements for development review applications to ensure the following:
  - i. That shadows cast by HIGH-RISE buildings do not substantially and adversely limit ground level ACCESS to sunlight on sidewalks and CIVIC SPACES.
  - ii. That by HIGH-RISE buildings pedestrian level wind velocities do not exceed acceptable levels for various activities existing or proposed at particular locations.
  - iii. That buildings do not CAUSE visual impairment or discomfort due to reflective spot glare and solar heat buildup in any nearby buildings.

# 10. DEVELOPMENT STANDARDS

## Wireless Communication

### 10.12 WIRELESS COMMUNICATION

#### 1. Purpose

- a. To facilitate effective and efficient telecommunication services throughout the city.
- b. To encourage the co-location and joint USE of new and existing wireless communication TOWERS and wireless communication ANTENNA locations.
- c. To minimize the total number of TOWERS throughout the community.
- d. To encourage the mounting of ANTENNAS to existing STRUCTURES.
- e. To ensure TOWERS and ANTENNAS are configured in a way that minimizes adverse visual impacts and reduces the impact of telecommunications STRUCTURES on public health and safety.
- f. To avoid potential damage to adjacent properties from TOWER and ANTENNA failure.

#### 2. Applicability

- a. This section is applicable to all wireless communication TOWERS, wireless communication ANTENNAS, and ANCILLARY STRUCTURES consistent with Sections 253 and 332(c)(7) of the Communications Act of 1934, as amended, and section 6409(a) of the Middle Class Tax Relief and Job Creation Act of 2012.
- b. Wireless communication TOWERS, wireless communication ANTENNAS, and ANCILLARY STRUCTURES are considered STRUCTURES and not regulated as a land USE.

#### 3. Development Review

- a. All DEVELOPMENT requires the submittal of a development review application to the BUILDING OFFICIAL.
- b. The DEVELOPMENT OR MODIFICATION of a wireless communication TOWER, wireless communication ANTENNA, OR ANCILLARY STRUCTURE requires a Special Permit in accordance with the provisions of §10.2.1. Special Permit, except as follows:
  - i. The DEVELOPMENT OR MODIFICATION of eligible facilities below the thresholds of Section 6409(a) of the Middle Class Tax Relief Act of 2012 requires only a pre-submittal meeting in accordance with the provisions of §10.1.1. Pre-Submittal Meeting, but does not require any further DEVELOPMENT review. Upon completion of the review of required application materials, the BUILDING OFFICIAL shall issue a Zoning Compliance Certificate to certify compliance with the provisions and procedures of this Ordinance.
- c. The DEVELOPMENT OR MODIFICATION of a wireless communication TOWER, wireless communication ANTENNA, OR ANCILLARY STRUCTURE requires a special permit according to the provisions of §10.2.1. Special Permit.
- d. The Zoning Board of Appeals is the review board

for the DEVELOPMENT OR MODIFICATION of all wireless communication TOWERS, wireless communication ANTENNAS, and their ANCILLARY STRUCTURES.

- e. APPLICANTS must submit a rendering or computer-simulated photograph illustrating the view of any proposed WIRELESS COMMUNICATIONS TOWER OR ANTENNA from at least three (3) prominent locations along the surrounding public THOROUGHFARES.
- f. In addition to the review criteria for all Special Permits specified in §15.2.1.e. Review Criteria, the review board shall make findings considering the following in its discretion to approve or deny a special permit authorizing a wireless communication TOWER, wireless communication ANTENNA:
  - i. Suitability of nearby, existing SITES and/or the feasibility of alternative technologies.
  - ii. Height and design of proposed TOWER OR ANTENNA, with particular concern for design solutions that reduce or eliminate visual impact.
  - iii. Compatibility with the USES associated with surrounding properties and proximity of the proposed TOWER OR ANTENNA to properties in residential USE.
  - iv. Topography, on-SITE vegetation, and the prominence of proposed facility.
  - v. Proposed ingress and egress for maintenance.

#### 4. Wireless Communication Towers

- a. Wireless communication TOWERS approved according to the provisions of this section may be built prior to or independent of any PRINCIPAL BUILDING TYPE ON A LOT.
- b. DEVELOPMENT Standards
  - i. Wireless communication TOWERS are not permitted to exceed the tallest BUILDING TYPE permitted for the district where they are located.
  - ii. Lighting is prohibited, except as required by the Federal Aviation Administration.
  - iii. SIGNS are prohibited, except as follows:
    - a). SIGNS required by the FAA, FCC, or other applicable authority;
    - b). no trespassing SIGNS or other notifications that alert the public to potential safety concerns;
    - c). a nameplate or SIGN identifying the name and phone number of the owner or operator.
  - iv. Wireless communication TOWERS must be set-back from any property line a distance equal to their height.

#### 5. Wireless Communication Antennas

- a. DEVELOPMENT Standards
  - i. Roof mounted ANTENNAS:
    - a). are not permitted to exceed ten (10) feet in



- height;
- b). must be SETBACK at least ten (10) feet from the edge of the roof; and
- c). are not permitted to project above a plane inclined at a forty-five degree (45°) angle from vertical, beginning at edge of the roof.
- ii. Wall or TOWER mounted ANTENNAS:
  - a). must be flush-mounted below any ROOF LINE of the STRUCTURE they are attached to,
  - b). must be at least forty (40) feet above the AVERAGE GRADE of the LOT, measured from the ground to the base of the ANTENNA; and
  - c). must be painted or otherwise screened in a way to match the colors or simulate the materials of the BUILDING or TOWER on which they are mounted.
- iii. Lighting is prohibited, except as required by the Federal Aviation Administration.
- iv. SIGNS are prohibited, except as follows:
  - a). SIGNS required by the FAA, FCC, or other applicable authority;
  - b). no trespassing SIGNS or other notifications that alert the public to potential safety concerns; or
  - c). a nameplate or SIGN identifying the name and phone number of the owner or operator.

### 6. Ancillary Structures

- a. STRUCTURES serving or being USED in conjunction with a wireless communication TOWER OR ANTENNA are considered ANCILLARY. Examples include utility or transmission equipment storage sheds or cabinets.
- b. An ANCILLARY STRUCTURE for WIRELESS COMMUNICATIONS does not require separate DEVELOPMENT review when installed in conjunction with an approved wireless communication TOWER OR ANTENNA.
- c. Any buildings, cabinets, or shelters may HOUSE only equipment and supplies for operation of the wireless communication TOWER OR ANTENNA.
- d. Any equipment not USED in direct support of such operation must not be stored on the SITE.
- e. The STRUCTURE must be un-staffed.
- f. SIGNS are prohibited, except as follows:
  - i. SIGNS required by the FAA, FCC, or other applicable authority;
  - ii. no trespassing SIGNS or other notifications that alert the public to potential safety concerns; or
  - iii. a nameplate or SIGN identifying the name and phone number of the owner or operator.

### 7. Design Guidelines

- a. TOWERS should only be USED in circumstances where no alternative BUILDING-mounted options are available.
- b. TOWERS facilities should be designed to structurally accommodate the maximum number of foreseeable

USERS.

- c. TOWERS and ANTENNAS should be located as follows:
  - i. on properties owned or managed by the City of Somerville or the Somerville Housing Authority;
  - ii. on properties located in the fabrication, commercial industry, or any mixed-USE district;
- d. When ANTENNAS for multiple service providers are located on a single SITE, the ANTENNAS should be co-located to reduce visual impact.
- e. ANTENNAS should be interior-mounted so that they are concealed from public view (e.g., inside church steeples, cupolas, bell-TOWERS, or penthouses), or side-mounting onto existing STRUCTURES in the least obtrusive location feasible, preferably with limited visibility from ABUTTING STREETS.
- f. Where existing ANTENNAS have been installed in stealth enclosures, new equipment should be installed in stealth enclosures designed to match those already on the SITE.
- g. Locations should be chosen with a sensitivity to the surrounding topography and predominant view corridors.
- h. ANTENNA technology should be chosen to minimize the visual effect of "massing" panels on a rooftop.
- i. To every extent possible, new co-located equipment should meet the same conditions applied to any original special permit authorizing the wireless communication TOWER OR ANTENNA on the SITE.
- j. Existing on-SITE vegetation should be preserved to the maximum extent practical.
- k. All network interconnections from the communications SITE should be via underground lines.

### 8. Abandonment

- a. If the owner of any WIRELESS COMMUNICATIONS TOWER OR ANTENNA communicates an intent to discontinue USE or if any TOWER OR ANTENNA is not operated for a continuous period of twelve (12) months, the TOWER OR ANTENNA, and any ANCILLARY STRUCTURES and equipment must be removed by the owner of the TOWER OR ANTENNA within ninety (90) days.

# 10. DEVELOPMENT STANDARDS

# 11 PARKING & MOBILITY

<b>11.1 BICYCLE PARKING .....</b>	<b>477</b>
General	477
Short-Term Bicycle Parking	477
Long-Term Bicycle Parking	478
Alternative Compliance	478
<b>11.2 MOTOR VEHICLE PARKING .....</b>	<b>478</b>
General	478
Parking Lots	480
Parking Structures	480
Flexible Use of Accessory Parking	480
Loading Facilities	481
Alternative Compliance	481
On-Street Parking in Transit Areas	481
<b>11.3 SHARED PARKING .....</b>	<b>482</b>
Purpose	482
Applicability	482
Restrictions	482
Reductions to Minimum Parking	482
Shared Parking Agreements	482
Signage	482
<b>11.4 MOBILITY MANAGEMENT .....</b>	<b>483</b>
Purpose	483
Applicability	483
Mobility Management Plan Required	483
Review Authority	483
Procedure	483
Mobility Management Plans	483
Annual Reporting & Monitoring	484
Compliance	484
Required Programs & Services	484
Definitions & Standards	484
Mobility Management Associations	486
Enforcement	486



## 11.1 BICYCLE PARKING

### 1. General

- a. Design Guidance
  - i. The City of Somerville's Bicycle Parking Guide and the latest version of the Association of Pedestrian and Bicycle Professionals Bicycle Parking Guidelines should be referenced for guidance.
- b. Size & Layout
  - i. Each bicycle parking space must be two (2) feet by six (6) feet in size or the minimum required by the manufacturer of a bicycle rack or locker, whichever is more.
- c. ACCESS
  - i. Areas designed for bicycle parking spaces must have a hard, stabilized surface.
  - ii. Bicycle parking spaces must have at least one (1) ACCESS aisle at least five (5) feet wide to allow room for maneuvering. This ACCESS aisle must be kept free from obstructions.
  - iii. Bicycle parking spaces must be ACCESSIBLE without moving another bicycle or lifting or carrying a bicycle over any steps or stairs.
  - iv. Outdoor ACCESS routes must be appropriately lighted to allow for safe nighttime USE.
- d. Weather Protection
  - i. When provided, weather protection must be permanent, designed to protect bicycles from rainfall, and provide no less than seven (7) feet of CLEARANCE above ground level.
- e. Bicycle Racks
  - i. All bike racks must:
    - a). Be a fixed-in-place stand that is securely anchored to the ground;
    - b). Provide support to the bicycle frame, allowing it to stand upright without the USE of a kick-stand, and prevent the bicycle from falling over;
    - c). Be configured to provide two points of contact to allow locking of the frame and at least one wheel with a USER-provided locking device;
    - d). Be constructed of materials that resist cutting, rusting, bending, or deformation; and
    - e). Be arranged in rows (with bicycles parked side-by-side) or in alignment (with bicycles parked end-to-end).
- f. Bicycle Lockers
  - i. All bicycle lockers must:
    - a). Be securely anchored to the ground;
    - b). Be configured to provide support to the bicycle, allowing it to stand upright without the USE of a kick-stand, and
    - c). Be secured by means of a lockable door or, alternatively, configured internally to allow locking of the frame and at least one wheel

Figure 11.1.1 Bicycle Parking Spaces

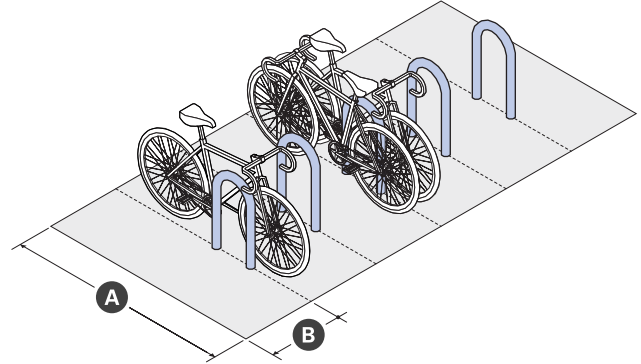

- with a USER-provided locking device.
  - g. SIGNage
    - i. If required bicycle parking is not visible from the STREET OR PRINCIPAL ENTRANCE(s), a SIGN must be posted at the PRINCIPAL ENTRANCE(s) indicating the location of the parking. The D4-3 SIGN from the Manual on Uniform Traffic Control Devices (MUTCD) is recommended (see Figure 11.1.1).
- ### 2. Short-Term Bicycle Parking
- a. SHORT-TERM BICYCLE PARKING may be provided in any combination of bicycle racks and bicycle lockers. Racks that are double height or require hanging of a bicycle are prohibited for SHORT-TERM BICYCLE PARKING.
  - b. SHORT-TERM BICYCLE PARKING must be provided outside of a PRINCIPAL BUILDING and within fifty (50) feet of the PRINCIPAL ENTRANCE of the USE served by the parking.
  - c. SHORT-TERM BICYCLE PARKING must be at the same grade as the ABUTTING sidewalk or at a location that can be reached by an ACCESSIBLE route from the sidewalk that is a minimum of five (5) feet wide, with no steps and a six percent (6%) slope or less.
  - d. Bike racks may be installed within the furnishing zone of a sidewalk of an ABUTTING public THOROUGHFARE provided that an ENCROACHMENT permit is granted by the City Council. A rack may also consist of a hoop affixed to a parking meter, with approval from the Director of Mobility.
    - i. Any required SHORT-TERM BICYCLE PARKING provided in a STRUCTURE or under cover must be:
      - a). Provided at ground level;
      - b). Provided free of charge;
      - c). Clearly marked as bicycle parking;
      - d). Separated from vehicle parking by a physical

# 11. PARKING & MOBILITY

## Motor Vehicle Parking

barrier to minimize the possibility of parked bicycles being hit by a vehicle; and

- e). Co-located in relative proximity to the nearest vehicular parking spaces.

### 3. Long-Term Bicycle Parking

- a. LONG-TERM BICYCLE PARKING may be provided through any combination of racks or lockers.
- b. LONG-TERM BICYCLE PARKING must be provided in a well-lit, secure location within the same BUILDING as the USE the parking is intended to serve or within an ACCESSORY STRUCTURE located within two-hundred (200) feet of the PRINCIPAL ENTRANCE of the BUILDING.
- c. To provide security, LONG-TERM BICYCLE PARKING must either be:
  - i. In a locked room;
  - ii. In an area that is enclosed by a fence with a locked gate. The fence must be either 8 feet high, or be floor-to-ceiling;
  - iii. Within view of an attendant or security guard;
  - iv. In an area that is monitored by a security camera; or
  - v. In an area that is visible from employee work areas.
- d. All required LONG-TERM BICYCLE PARKING spaces must be designed to provide continuous shelter from the elements.
- e. LONG-TERM BICYCLE PARKING serving multiple USES may be combined into a single area of ACCESSORY STRUCTURE.
- f. Where LONG-TERM BICYCLE PARKING is located adjacent to MOTOR VEHICLE PARKING or loading facilities, a physical barrier must be provided to prevent potential damage to bicycles by other vehicles.
- g. When twenty (20) or more long term bicycle parking

spaces are provided, a minimum of five percent (5%) of the spaces must be three (3) feet by eight (8) feet in size to accommodate tandem bicycles or bicycles with trailers.

- h. No more than twenty five (25%) of long term bicycle parking space may be provided as racks that require bicycles to be hung or lifted off the ground or floor.

### 4. Alternative Compliance

- a. The provisions of Section 11.1 may be modified by Special Permit to accommodate alternative technologies and methods for providing bicycle parking.
  - i. In addition to the review criteria for all Special Permits specified in §15.2.1.e. Review Criteria, the review board shall make findings considering the following in its discretion to approve or deny a Special Permit to modify the provisions of Section 11.1 Bicycle Parking:
    - a). The ability of alternative technologies and methods of bicycle parking to provide equal or greater benefits to bicycle users.

## 11.2 MOTOR VEHICLE PARKING

### 1. General

- a. Approval by the City Engineer Required
  - i. All CURB CUTS, driveways, parking spaces, and PARKING LOTS must comply with the applicable provisions of Chapter 11, Article II, Sec. 11-33 Driveway Construction of The Code of Ordinances, City of Somerville, Massachusetts.
- b. Permitted Types
  - i. Zoning districts include restrictions on the type of off-STREET parking that is permitted in each district.
- c. Parking SETBACKS
  - i. All off-STREET parking, excluding underground STRUCTURED PARKING, must be located at or behind the required parking SETBACK as indicated for each BUILDING TYPE.
  - ii. Parking is never permitted within a FRONTAGE AREA.
- d. ACCESS
  - i. All off-STREET parking must have direct ACCESS to a public THOROUGHFARE from an ALLEY, driveway, maneuvering aisle, or permanent ACCESS EASEMENT.
  - ii. If an ALLEY is provided, all off-STREET parking must be ACCESSED from the ALLEY.
- e. Circulation
  - i. PARKING LOTS and STRUCTURES must be designed so that vehicles enter or exit onto a public THOROUGHFARE in a forward direction rather than backing out into the roadway.
  - ii. Ingress and egress from individual parking spaces must be from a drive aisle or driveway.
  - iii. Vehicles are not permitted to enter or exit parking

Figure 11.1.1 MUTCD Figure D4-3





**Table 11.2.1 Parking Space & Drive Aisle Dimensions**

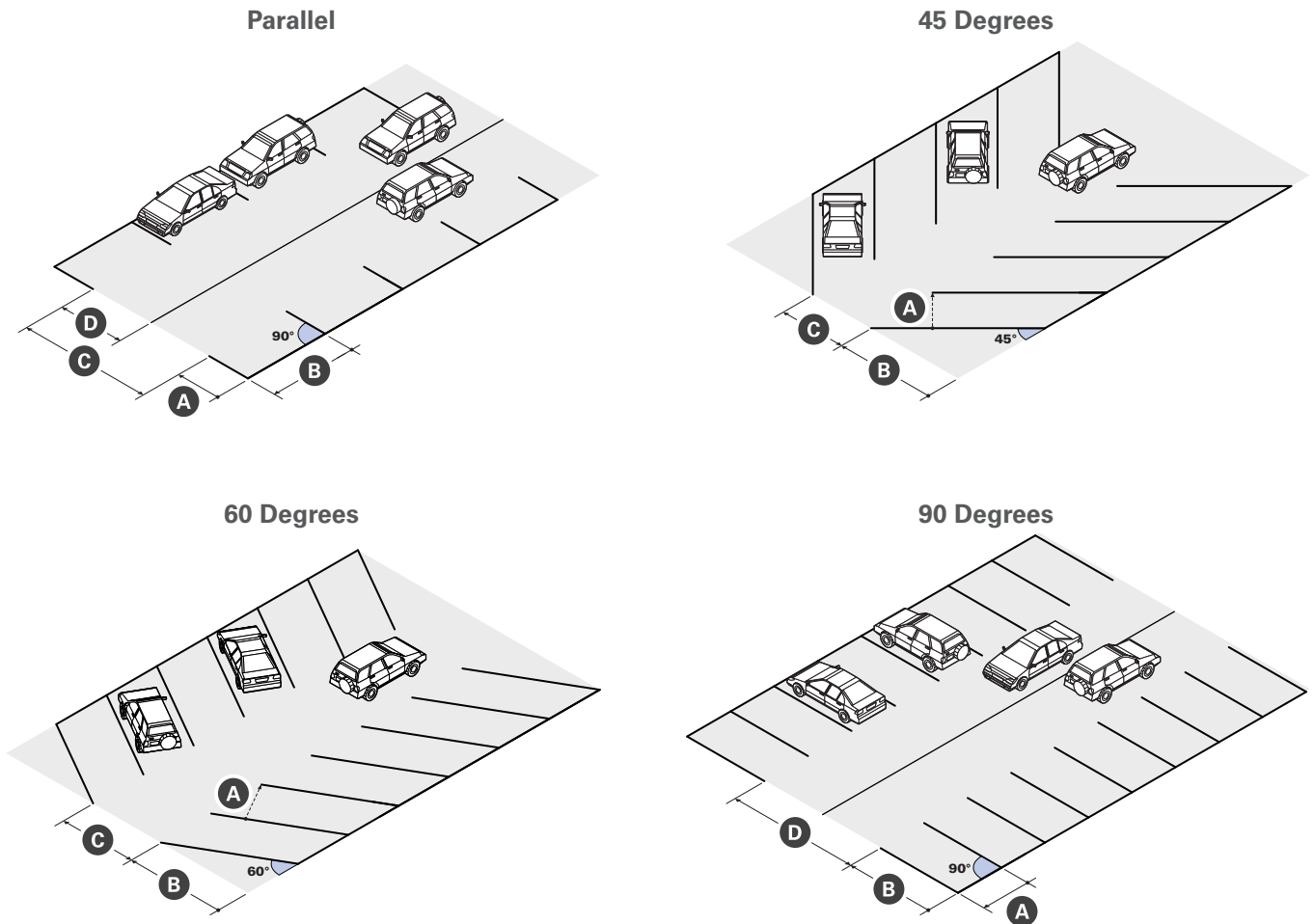

	Parallel	45 Degrees	60 Degrees	90 Degrees
<b>A</b> Stall Width (min)	8 ft	N/A	N/A	8 ft
<b>B</b> Stall Length (min)	16 ft	18 ft	18 ft	16 ft
<b>C</b> Drive Aisle, 1 Way (min)	12 ft	12 ft	12 ft	N/A
<b>D</b> Drive Aisle, 2 Way (min)	20 ft	N/A	N/A	20 ft
<b>E</b> Vertical CLEARANCE (min)	7.5 ft	7.5 ft	7.5 ft	7.5 ft

spaces directly from a public THOROUGHFARE except as follows:

- a). PARKING LOTS with six (6) or less parking spaces may be designed to permit motor vehicles to enter or exit a parking space directly from a rear ALLEY by special permit.
- b). In addition to the review criteria for all Special Permits specified in §15.2.1.e. Review Criteria, the review board shall make findings considering the following in its discretion to

approve or deny a special permit authorizing parking spaces that are directly accessible from a rear ALLEY:

- i). Adequate ALLEY width and surface material to accommodate vehicular turning movements.
- ii). Location of ALLEY intersections in relation to the safety of pedestrians, bicyclists, and motor vehicles.
- iii). Sight lines needed by the driver of any

# 11. PARKING & MOBILITY

## Motor Vehicle Parking

vehicle entering or exiting the SITE.

- f. Parking Space & Drive Aisle Dimensions
  - i. All parking spaces and drive aisles must comply with the minimum dimensional standards shown in Table 11.2 (a), with the following exceptions:
    - a). Motorcycle and scooter parking stalls must measure at least four feet in width and eight feet in depth.
    - b). Mechanical ACCESS parking is exempt from parking stall and drive aisle dimensional requirements.
    - c). When twenty (20) or more spaces are required, up to twenty percent (20%) of those spaces may be designed as parking for compact cars with the minimum stall length reduced to sixteen (16) feet and minimum stall width reduced to seven and one half (7.5) feet. Compact spaces must be clearly identified with a pavement marking and SIGNAGE.
    - d). When the side of a parking space ABUTS a wall or other obstruction that is taller than six (6) inches, the width of the parking space must be increased by one foot.
  - g. Accessibility
    - i. All parking spaces, LOTS, and STRUCTURES must comply with relevant State and Federal regulations for parking designed for persons with disabilities, including 521 CMR 300.
  - h. Lighting
    - i. All off-STREET parking must be provided with adequate light for USE at night in accordance with the provisions of §6.H. Outdoor Lighting.
  - i. SIGNAGE
    - i. All traffic control SIGNS must be installed in accordance with the Manual of Uniform Traffic Control Devices (MUTCD).

### 2. Parking Lots

- a. GENERAL
  - i. SURFACE PARKING LOTS are permitted by Site Plan Approval
- b. ACCESS
  - i. Pedestrian ACCESS from PARKING LOTS must lead directly to a public sidewalk (i.e., not directly into a BUILDING).
- c. Design & Construction
  - i. No SURFACE PARKING LOT may have a grade in excess of ten percent (10%).
  - ii. Individual parking spaces must be delineated with paint or similar method and maintained in clear, visible condition to identify the parking spaces from drive aisles and other circulation features.
  - iii. Wheel stops, bumper guards, or other alternatives must be installed to prevent vehicles from

damaging or ENCROACHING upon any sidewalk, landscaping, fence, wall, or STRUCTURE and must be properly anchored and secured into the ground.

- iv. PARKING LOTS ABUTTING, within fifty (50) feet, or visible from the right-of-way of a public THOROUGHFARE, except ALLEYS, must be effectively screened by a perimeter wall or fence.
  - a). Perimeter walls and fences must be no more than four (4) feet in height measured from the surface of the LOT, no less than fifty percent (50%) opaque, and designed to allow surveillance over and beyond the wall or fence by pedestrians approaching or passing the PARKING LOT.
- d. Capacity
  - i. Unless otherwise specified, the actual parking of motor vehicles in excess of the number of parking spaces delineated in a PARKING LOT is prohibited.

### 3. Parking Structures

- a. Vehicular Entrances
  - i. Vehicular entrances to PARKING STRUCTURES may be no more than twenty four (24) feet in width.
- b. ACCESS
  - i. Pedestrian ACCESS to STRUCTURED PARKING must lead directly to a public sidewalk (i.e., not directly into a BUILDING), except underground levels which may be exited by pedestrians directly into a BUILDING.
- c. FACADE Design
  - i. Unless SETBACK by space designed for occupancy by non-parking USES, the FACADE of any STORY of a BUILDING occupied by MOTOR VEHICLE PARKING must be designed as follows:
    - a). FENESTRATION must be vertically and horizontally aligned and all floors fronting on the FACADE must be level (not inclined).
    - b). The FACADE must include FENESTRATION designed to appear as windows for between twenty percent (20%) and fifty percent (50%) of the wall area of each floor.
    - c). Windows must be back-lit during evening hours and internal LIGHT SOURCES must be concealed from view from public sidewalks.
    - d). The FACADE area masking the floors occupied by MOTOR VEHICLE PARKING must be seamlessly integrated into the architectural design of the BUILDING'S FACADE.

### 4. Flexible Use of Accessory Parking

- a. When existing ACCESSORY parking spaces are not needed to meet the parking demand of a PRINCIPAL USE (such as when the PRINCIPAL USE is closed for business), the PROPERTY OWNER may make the unused or under-utilized parking spaces available for other USES, including

# 11. PARKING & MOBILITY

## Motor Vehicle Parking

COMMERCIAL PARKING, when permitted in the district where the LOT is located.

### 5. Loading Facilities

- a. General
  - i. Buildings providing space for USES that regularly receive or distribute large quantities of goods must provide loading facilities as required by the Director of Mobility. Loading facilities must be sufficient to adequately serve the intended USE(S).
  - ii. The Director of Mobility may authorize the USE of an ALLEY for loading activities in lieu of requiring a separate on-SITE loading facility.
  - iii. Loading and unloading activities are not permitted within a public THOROUGHFARE except in a loading zone during permitted hours designated by the Director of Mobility.
- b. Design & Construction
  - i. Loading facilities, including all docks and areas USED for the storing and staging of materials being transported to or from the SITE, must be fully enclosed within a BUILDING or located to the side or rear of buildings and screened from view from any public THOROUGHFARE (excluding ALLEYS) or CIVIC SPACE according to §10.7. Screening.
  - ii. Common loading facilities may be shared by two or more buildings or multiple USES within the same BUILDING with the approval of the Director of Mobility.
- c. Neighborhood Compatibility
  - i. Loading and unloading activities may not ENCROACH on or interfere with the USE of sidewalks, drive aisles, or parking areas, or public THOROUGHFARES.
  - ii. Maneuvering aisles and driveways may serve both required parking and loading bays if they meet the design needs of each activity.
  - iii. Loading facilities requiring vehicles to back in from a public THOROUGHFARE are permitted.
  - iv. Loading and unloading activities for LOTS ABUTTING the NR or UR districts are limited to the hours of the day between 7:00 a.m. and 10:00 p.m. All loading docks on these LOTS must be SIGNED to indicate 'no idling'.

### 6. Alternative Compliance

- a. The provisions of Section 11.2 may be modified by Special Permit to accommodate alternative technologies and methods for providing MOTOR VEHICLE PARKING.
  - i. In addition to the review criteria for all Special Permits specified in §15.2.1.e. Review Criteria, the review board shall make findings considering the following in its discretion to approve or deny a Special Permit to modify the provisions of Section

11.2 Motor Vehicle Parking:

- a). The ability of alternative technologies and methods of MOTOR VEHICLE PARKING to provide equal or greater benefits to motor vehicle USERS.

### 7. On-Street Parking in Transit Areas

- a. Upon the adoption of an official policy limiting on-STREET residential parking permits in TRANSIT AREAS, the review boards shall require the following as a condition(s) of any discretionary or administrative permit:
  - i. that the APPLICANT complete and file formal acknowledgement that all DWELLING UNIT(S) are ineligible to participate in the Somerville Residential Permit Parking program with the with the Middlesex South Registry of Deeds or Land COURT prior to the issuance of a building permit;
  - ii. that all DWELLING UNITS are advertised as ineligible to participate in the Somerville Residential Permit Parking program; and
  - iii. that all buyers grantees, lessees, renters, or tenants are informed that all DWELLING UNIT(S) is ineligible to participate in the Somerville Residential Permit Parking program.

# 11. PARKING & MOBILITY

## Shared Parking

### 11.3 SHARED PARKING

#### 1. Purpose

- a. To allow parking to be shared between USES on the same LOT or between buildings on the same BLOCK when the actual demand for parking is less than the total number of spaces required by this Ordinance for each individual USE.
- b. To help prevent land from being unnecessarily devoted to the parking of motor vehicles.
- c. To support the efficient USE of Somerville’s limited land area for productive USES that contribute toward the City’s tax base.
- d. To encourage the efficient USE of existing parking resources.
- e. To help reduce impermeable surfaces and associated storm water runoff and pollution.

#### 2. Applicability

- a. This section is applicable to all real property located outside of a TRANSIT AREA and subject to a minimum parking requirement by this Ordinance.
- b. MOTOR VEHICLE PARKING spaces may be shared between USES on the same LOT and buildings on the same BLOCK as specified elsewhere in this Ordinance.

#### 3. Restrictions

- a. Accessible parking space (for persons with disabilities) may not be shared and must be provided on-SITE.

#### 4. Reductions to Minimum Parking

- a. DEVELOPMENT proposing to share parking may USE Table 11.3 (a) to reduce the number of MOTOR VEHICLE PARKING spaces required for the combined USES.
- b. Activities qualifying as evening commercial include all USES from the ASSEMBLY OR ENTERTAINMENT, Bar/ Restaurant/Tavern, Hotel/Hostel, and Private, Non-Profit Club or Lodge USE categories.
- c. The reduction to minimum parking requirements due to SHARED PARKING is calculated as follows:
  - i. Replace each ‘X’ on Table 11.3 (a) with the total number of MOTOR VEHICLE PARKING spaces required for all commercial USES. See the Vehicular Parking table

for the zoning district where the LOT is located to determine this number.

- ii. Replace each ‘Y’ on Table 11.3 (a) with the total number of MOTOR VEHICLE PARKING spaces required for all residential USES. See the Vehicular Parking table for the zoning district where the LOT is located to determine this number.
- iii. Multiple the number required by §11.3.3.i and §11.3.3.ii (above) as indicated for each time SLOT for all three columns of Table 11.3 (a).
- iv. Add the result of each cell together for each row on Table 11.3 (a).
- v. The row (time period) with the highest total parking requirement is the reduced minimum number of parking spaces that are required for all participating USES.

#### 5. Shared Parking Agreements

- a. SHARED PARKING requires a written agreement among all owners of record.
- b. An attested copy of the agreement between the owners of record must be submitted to the BUILDING Department and in a form deemed acceptable by the City Solicitors Office prior to and as a condition of the issuance of a BUILDING Permit.
- c. Revocation of an existing parking agreement will only be accepted if the required OFF-STREET PARKING SPACES are provided in accordance with the standards for the district where each property is located.

#### 6. Signage

- a. SHARED PARKING facilities must provide SIGNAGE identifying the permitted USERS.

**Table 11.3 (a) SHARED PARKING Calculation**

Time of Day	Commercial	Evening Commercial	Residential	Total
<b>6am - 9am</b>	( X ) * 25%	( X ) * 0%	( Y ) * 100%	= sum of this row
<b>9am - 7pm</b>	( X ) * 100%	( X ) * 50%	( Y ) * 65%	= sum of this row
<b>7pm - 11pm</b>	( X ) * 25%	( X ) * 100%	( Y ) * 100%	= sum of this row
<b>11pm - 6am</b>	( X ) * 0%	( X ) * 25%	( Y ) * 100%	= sum of this row

## **11.4 MOBILITY MANAGEMENT**

### **1. Purpose**

- a. To improve transportation options available to travelers, promote the USE of efficient travel modes, and reduce the need to travel.
- b. To decrease vehicular air pollutant emissions, conserve energy resources, and reduce ambient noise levels by reducing vehicular trips, total vehicle miles traveled, and traffic congestion within the city.
- c. To reduce automobile dependence and the associated costs of owning, operating, and maintaining an automobile.
- d. To decrease costs associated with the construction, repair, maintenance, and improvement of city THOROUGHFARES and parking facilities.
- e. To decrease the cost of traffic enforcement and promote traffic safety.
- f. To reduce the demand for parking facilities and increase the capacity and efficiency of existing transportation INFRASTRUCTURE.
- g. To support a fiscal return on federal, state, and local financial investment made in public transportation INFRASTRUCTURE by increasing ridersHIP of public transportation services.
- h. To incorporate transportation planning considerations into DEVELOPMENT review.
- i. To encourage the establishment of agencies or associations to manage MOBILITY MANAGEMENT programs and services implemented within the city.

### **2. Applicability**

- a. This Section is applicable to the following:
  - i. DEVELOPMENT of any BUILDING TYPE with fifty thousand (50,000) gross square feet or more of commercial floor area.
  - ii. DEVELOPMENT of any multi-tenant BUILDING that has non-residential USES with a combined total of fifty (50) or more employees.
  - iii. Non-residential USES with fifty (50) or more employees.
  - iv. DEVELOPMENT of any BUILDING with twenty (20) or more total DWELLING UNITS.
  - v. HOTEL OR HOSTEL USES with fifty (50) or more rooms or beds.
  - vi. COMMERCIAL PARKING USES.

### **3. Mobility Management Plan Required**

- a. A MOBILITY MANAGEMENT plan (MMP) is required for all DEVELOPMENT and for Coordinated DEVELOPMENT Special Permit applications.
- b. Development review applications are not considered complete and will not be scheduled for a public hearing until the Director of Mobility has approved the

proposed MOBILITY MANAGEMENT plan.

- c. Review boards may not issue a special permit, Site Plan Approval, or HardSHIP Variance; and the BUILDING OFFICIAL may not issue a zoning compliance certificate, BUILDING Permit, certificate of occupancy, or any other permit; until the Director of Mobility has approved the proposed MOBILITY MANAGEMENT plan.

### **4. Review Authority**

- a. The Director of Mobility, or their designee, is responsible for reviewing, conditioning, approving, and denying MOBILITY MANAGEMENT plans and annual reports.

### **5. Procedure**

- a. MOBILITY MANAGEMENT plans must be submitted to the Director of Mobility prior to or simultaneously with development review applications.
- b. The Director of Mobility shall issue a written preliminary decision within thirty (30) days of receipt of the MOBILITY MANAGEMENT plan indicating approval, approval with conditions, or denial of the proposed plan.
- c. The Director of Mobility shall issue a written final decision within sixty (60) days of receipt of the MOBILITY MANAGEMENT plan indicating approval, approval with conditions, or denial of the proposed plan. The final decision of the Director of Mobility must be posted on the City WEBSITE.
- d. Upon mutual agreement by the APPLICANT and the Director of Mobility, the time limits required of the Director to issue a preliminary and final decision may be extended. Mutual agreement of extended time limits must be recorded in writing.
- e. Failure by the Director of Mobility to issue a written final decision within sixty (60) days or any extended time period, if applicable, is deemed to be constructive approval of the proposed MOBILITY MANAGEMENT plan.
- f. The commitments and obligations of an approved MOBILITY MANAGEMENT plan are automatically transferred to the new PROPERTY OWNER when real property subject to the provisions of this Section is exchanged between private parties.
- g. The Director of Mobility shall issue a reconciliation letter to address any conditions applied by the review boards to a discretionary or administrative permit approval required for DEVELOPMENT subject to the provisions of this Section.

### **6. Mobility Management Plans**

- a. The Director of Mobility shall establish submittal requirements for MMPs. The Director shall make the submittal requirements available to the public on the City WEBSITE.
- b. MMPs for buildings or USES must include, but may not

# 11. PARKING & MOBILITY

## Mobility Management

be limited to, the following:

- i. A commitment to control the percentage of trips made by automobile at fifty percent (50%) or less.
  - ii. Identification of who, what, when, where, and how each required or proposed program and service will be implemented or, if unknown at that time, establish a time-line with milestones for when those outstanding questions will be answered.
- c. The cost associated with drafting a MOBILITY MANAGEMENT plan, annual updates, and all monitoring and reporting is borne by PROPERTY OWNER.

### 7. Annual Reporting & Monitoring

- a. MOBILITY MANAGEMENT plans must be updated on an annual basis and submitted for approval to the Director of Mobility to validate continued compliance with the provisions of this Section.
- b. If annual monitoring and reporting identifies a shortfall in meeting the MMP's commitments, adjustments to existing programs and services or additional programs and services must be implemented.
- c. For the first two (2) years of occupancy or operations, annual updates must identify existing SITE based parking conditions, travel behavior of employees or residents, and identify the metrics and methods USED for performance review.
- d. After two (2) years of occupancy or operations, a MOBILITY MANAGEMENT plan must also identify objective targets to reduce parking demand, single-occupant vehicle trips, vehicle miles traveled, or automobile vehicle trips associated with DEVELOPMENT, based on the performance review of previous years, and propose adjustments to existing programs and services or additional programs & services to achieve those objectives.
- e. To ascertain the level of success for implemented programs and services, incentives, and other measures, annual updates to MOBILITY MANAGEMENT plans must include, but may not be limited to, the following:
  - i. A statistically valid travel survey of employees and residents, as applicable.
  - ii. Annual reporting of parking utilization and operations for any Commercial Service Vehicular Parking facility.
  - iii. Biennial counts of automobile trips entering & exiting any parking facilities.
  - iv. A status update on the implementation of programs and services.

### 8. Compliance

- a. The review boards shall require compliance to a MOBILITY MANAGEMENT plan, as approved by the Director of Mobility, as a condition of any discretionary or

administrative permit required for DEVELOPMENT subject to the conditions of this Section.

- b. The review boards may require the posting of a bond or other performance guarantee to ensure implementation of an approved MOBILITY MANAGEMENT plan and compliance with the provisions of this section.

### 9. Required Programs & Services

- a. Commercial PROPERTY OWNERS must provide the following for their tenants:
  - i. On-SITE Transportation Coordinator
  - ii. Posted Information
  - iii. Distributed Information
  - iv. Unbundled Parking
  - v. Preferential Parking for Carpool/Vanpool
  - vi. Qualified Transportation Fringe Benefits
  - vii. Guaranteed Ride Home Program
  - viii. Annual Mobility Educational Meeting
- b. Commercial PROPERTY OWNERS must require future tenants to provide the following to their employees through lease agreements:
  - i. Guaranteed Ride Home Program
  - ii. Qualified Transportation Fringe Benefits
- c. Commercial USES must provide the following for their employees:
  - i. On-SITE Transportation Coordinator
  - ii. Posted Information
  - iii. Distributed Information
  - iv. Qualified Transportation Fringe Benefits
  - v. Guaranteed Ride Home Program
  - vi. Annual Mobility Educational Meeting
- d. HOTEL OR HOSTEL USES must provide the following:
  - i. Shuttle Services
- e. COMMERCIAL PARKING USES must provide the following:
  - i. Posted Information
  - ii. Preferential Parking for Carpool/Vanpool
- f. Residential PROPERTY OWNERS with twenty (20) or more DWELLING UNITS must provide the following:
  - i. Posted Information
  - ii. Distributed Information
  - iii. Unbundled Parking
  - iv. Car Share Vehicle Spaces
- g. A MOBILITY MANAGEMENT plan may voluntarily include additional programs and services.
- h. Programs and services not identified in this section may be proposed and included in a MOBILITY MANAGEMENT Plan with the approval of the Director of Mobility.

### 10. Definitions & Standards

- a. Financial Incentives
  - i. Car-Sharing/Bike-Sharing MEMBERSHIPS: Full or partial EMPLOYER-funded monthly MEMBERSHIPS for



# 11. PARKING & MOBILITY

## Mobility Management

- ii. local car-sharing and bike-sharing services.
- ii. Parking Cash-Out Program: An EMPLOYER-funded cash payment made available to employees who choose not to USE a parking space in an EMPLOYER subsidized PARKING LOT or facility.
- iii. Qualified Transportation Fringe Benefits: A 'Commuter Tax Benefit' that allows EMPLOYERS to save on payroll related taxes or employees to save on federal income taxes in accordance with the Internal Revenue Code through the provision of either Pre-Tax Payroll Deductions for Transit Passes/ Vanpool Costs or Subsidized Transit Passes.
- b. Shared Vehicle Services
  - i. Bikes at Work: Bicycles available on-SITE during the workday for employee business and personal USE.
  - ii. Bike Share Station: Bike sharing vehicles available on-SITE for public USE.
  - iii. Car Share Vehicle Spaces: On-SITE parking spaces provided at no cost for car-sharing vehicles.
  - iv. Fleet Vehicle(s): Company owned vehicle(s) available on-SITE during the workday for employees that carpool, vanpool, bike, walk, or take transit.
  - v. Guaranteed Ride Home Program: An EMPLOYER subsidized ride home for employees that carpool, vanpool, bike, walk, or take transit.
    - a). Transportation must be provided to an employee for:
      - i). Emergency situations of the employee or a family member;
      - ii). Illness of the employee or a family member;
      - iii). Unscheduled overtime; and
      - iv). Bicycle damage.
    - ii). Availability of the ride home service may be restricted to no less than four (4) times per calendar year.
  - vi. Ride Matching Services: A no cost service to help employees interested in carpooling locate other interested carpoolers with similar schedules, routes, and destinations.
  - vii. Shuttle Services: Smaller BUSES or vans providing complimentary transportation for employees and guests.
  - viii. Visitor Commute Support: Full or partially funded daily transit passes or daily memberships for local car-sharing and bike-sharing services.
- c. Employment Programs
  - i. Flexible Work Hours: Compressed workweeks, flexible work hours, and staggered work shifts.
  - ii. Teleworking: Policies to permit and encourage employees to work from home or off-SITE.
- d. Marketing & Education
  - i. Bike Commuting Training: Classes (education and hands-on training) to encourage employee bike commuting offered on-SITE or through a third party provider.
- ii. Distributed Information: Printed materials issued annually to all tenants and employees, and to new employees and tenants at the time of hire or occupancy, providing the following information:
  - a). Current maps identifying station locations, routes, and schedules for public transit serving the SITE;
  - b). Bicycle route and facility information, including regional/local bicycle maps;
  - c). A listing of facilities available for carpoolers, vanpoolers, bicyclists, transit riders and pedestrians at the SITE.
- iii. On-SITE Transportation Coordinator: a person with the responsibility to implement and administer the programs and services of an approved MOBILITY MANAGEMENT Plan and serve as a point of contact to the City of Somerville.
- iv. Posted Information: A bulletin board, display case, or kiosk located in a BUILDING lobby, common area, or other conspicuous location displaying the following information:
  - a). Current maps identifying station locations, routes, and schedules for public transit serving the SITE;
  - b). Bicycle route and facility information, including regional/local bicycle maps;
  - c). A listing of facilities available for carpoolers, vanpoolers, bicyclists, transit riders and pedestrians at the SITE.
- v. Transportation Signage: Wayfinding providing directions to and clearly identifying transportation facilities such as TRANSIT STATIONS, bus stops, bicycle parking, carpool spaces, etc.
- e. Parking Management
  - i. Charging for Employee Parking: Elimination of existing subsidies for off-SITE employee parking and charging for on-SITE employee parking.
  - ii. Demand-Responsive Pricing: Adjustable hourly rates charged for employee or customer parking to manage parking availability.
  - iii. Parking Lease Adjustments: Rental of parking spaces on a monthly rather than yearly basis.
  - iv. Preferential Parking for Carpool/Vanpool: Parking spaces located in a preferential location and reserved for registered carpool and vanpool vehicles.
  - v. SHARED PARKING: Parking spaces shared by two (2) or more USES.
  - vi. Unbundled Parking: Parking spaces rented, leased, or sold as an option rather than a requirement of the rental, lease, or purchase of a DWELLING UNIT OR

# 11. PARKING & MOBILITY

## Mobility Management

non-residential floor space.

- f. On-SITE Services
  - i. Bicycle Repair Station: On-SITE bike repair station or room available for residents or employees.
  - ii. Child Care: The caring for and supervision of children available on SITE for employees.
  - iii. Concierge Services: an employee of an apartment BUILDING, hotel or office BUILDING providing services to residents or employees.
  - iv. On-SITE Transit Pass Sales: Retail sales of public transportation passes.

### 11. Mobility Management Associations

- a. MOBILITY MANAGEMENT ASSOCIATIONS are organizations formed to help individual USES and PROPERTY OWNERS collectively implement and administer the programs and services required by this Section.
- b. A representative from an approved MOBILITY MANAGEMENT ASSOCIATION may jointly represent EMPLOYERS, parking facility operators, and PROPERTY OWNERS subject to the provisions of this Section in place of a required on-SITE transportation coordinator.

### 12. Enforcement

- a. In accordance with §1.1.7. Fines & Penalties, the BUILDING OFFICIAL shall consider each day as a separate offense for DEVELOPMENT that is not in compliance with the provisions of this Section.

# 12 DEVELOPMENT BENEFITS

<b>12.1 AFFORDABLE HOUSING .....</b>	<b>489</b>
Purpose	489
Applicability	489
Enforcement	489
Required ADUs	489
ADU Price	489
Purchase & Tenancy Standards	490
ADU Development Standards	491
Implementation Plans and Covenants	492
Buyouts & Payments	492
Compliance	493
Performance Review	493
<b>12.2 LINKAGE .....</b>	<b>494</b>
Applicability	494
Affordable Housing Linkage	494
Employment Linkage	494
Green Line Linkage	495
Civic Space Linkage	495
Performance Review	495



## 12.1 AFFORDABLE HOUSING

### 1. Purpose

- a. To implement the housing policy objectives of the COMPREHENSIVE PLAN of the City of Somerville by increasing the supply of affordable housing available to existing and future residents.
- b. To create a stock of affordable housing that is available to qualifying households over the long-term.
- c. To stabilize the cost of housing, including utilities, parking, and on-site amenities for households that are unable to afford market-rate housing prices without becoming COST BURDENED.
- d. To ensure that fractional buyouts and in-lieu payments compensate for the additional costs of acquisition, design, DEVELOPMENT, operations, and maintenance in addition to the value of an AFFORDABLE DWELLING UNIT.
- e. To recapture a public benefit from the increased value of land resulting from the adoption of this Ordinance.

### 2. Applicability

- a. This Section is applicable to all DEVELOPMENT required to provide one (1) or more AFFORDABLE DWELLING UNITS (ADUs) and to any SUBDIVISION or LOT SPLIT that results in two or more LOTS intended for residential use, sale, legacy, or DEVELOPMENT at any time.
- b. DEVELOPMENT may not be segmented or phased in any manner and APPLICANTS may not establish surrogate or subsidiary entities to avoid compliance with this Section.
- c. Residential uses owned by an educational institution for occupancy exclusively by its students, faculty, and staff are exempt.
- d. 100% AFFORDABLE HOUSING buildings are exempt.

### 3. Enforcement

- a. The Director of Housing may establish additional standards and procedures for the administration enforcement of this Section.

### 4. Required ADUs

- a. Unless otherwise specified, ADUs must be provided as specified in Article 3: Residential Districts, Article 4: Mid-Rise Districts, Article 5: High-Rise Districts, Article 7: Special Districts, and Article 8: Overlay Districts.
- b. When the calculation for AFFORDABLE DWELLING UNITS results in a fractional value, the fractional value is either rounded up to the next whole number and regarded as a whole unit or, alternatively, a buyout may be paid for the fractional value in accordance with §12.1.8 Buyouts & Payments.
- c. Applicants may request to make a payment in lieu of providing one (1) or more required ADUs in accordance with §12.1.8 Buyouts & Payments.

- d. DEVELOPMENT that results in elimination or discontinuance of an existing ADU is required to replace the unit(s) on a one-for-one basis or provide the number required ADUs for the subject building type, whichever is more.

### 5. ADU Price

- a. Unless otherwise specified, ADUs required by this Ordinance must be priced as specified on Table 12.1.4 (a) ADU Price Tiers.

**Table 12.1.5 (a) ADU Price Tiers**

ADU	Price Tier
1st ADU	Tier 1
2nd ADU	Tier 2
3rd ADU	Tier 1
4th ADU	Tier 2
5th ADU	Tier 3
6th ADU	Tier 1
7th ADU	Tier 2
8th ADU	Tier 1
9th ADU	Tier 3
10th ADU	Tier 2
11th ADU	Tier 1
12th ADU	Tier 2
13th ADU	Tier 3

- b. The Director of Housing shall calculate, publish on the City website, and annually update the following:
  - i. The maximum rent and maximum sales price for each ADU price tier.
  - ii. Standard deductions for condominium fees, homeowners insurance, private mortgage insurance, real estate taxes, and parking fees for ownership ADUs.
  - iii. Standard deductions for utilities, parking, and amenities for rental ADUs.
- c. The maximum affordable rent for each rental ADU price tier is calculated as follows:
  - i. The Median Family Income (MFI) for the Boston-Cambridge-Quincy, MA-NH HUD Metro FMR Area published annually by the U.S Department of Housing and Urban Development (HUD) is multiplied by the percentage specified on Table 12.1.5 (b) for the price tier and BEDROOM count of the subject ADU to determine the base price before deductions.

## 12. DEVELOPMENT BENEFITS

### Affordable Housing

- ii. The product of the above is divided by twelve (12) and the standard deductions for utilities, parking, and amenities provided at additional cost to tenants is subtracted from the result to determine the maximum monthly rent. For example, the estimated monthly rent of a Tier 1, two (2) BEDROOM ADU would be \$531.40 per month based on the following:
  - a). \$113,300 (the 2019 MFI for the Boston Metro FMR Area) multiplied by 9.6% from Table 12.1.5 (b) (\$10,876.80) divided by twelve (12) months (\$906.40) minus an estimated standard deduction of three hundred and seventy five dollars (\$375) for utilities, parking, and amenities.
- d. The maximum affordable sales price for each ownership ADU price tier is calculated as follows:
  - i. The Median Family Income (MFI) for the Boston-Cambridge-Quincy, MA-NH HUD Metro FMR Area published annually by the U.S Department of Housing and Urban Development (HUD) is multiplied by the percentage specified on Table 12.1.4 (c) for the price tier and BEDROOM count of the subject ADU.
  - ii. The the product of the above is then divided by twelve and the standard deductions for private mortgage insurance, real estate taxes, condominium fees, homeowners insurance, and parking fees, if any, are subtracted from the result to determine a maximum monthly mortgage payment. For example, the estimated maximum monthly mortgage payment for a Tier 1, two (2) BEDROOM ADU would be \$1,105.45 per month based on the following:
    - a). \$113,300 (the 2018 MFI for the Boston Metro FMR Area) multiplied by 15.68% from Table 12.1 (d) (\$17,765.44) divided by twelve (12) months (\$1,480.45) minus an estimated standard deduction of three hundred and seventy five dollars (\$375) for private mortgage insurance, real estate taxes, condominium fees, homeowners insurance, and parking fees.
  - iii. The result of the above is used to calculate a maximum mortgage loan amount, assuming a thirty (30) year term and a current conventional interest rate, and the maximum mortgage loan amount is multiplied by 1.03 to determine the maximum affordable sales price.

### 6. Purchase & Tenancy Standards

- a. The Director of Housing shall calculate, publish on the City website, and annually update the following:
  - i. The actual maximum annual income eligibility requirements for households selected to rent or purchase an ADU:
  - b. The maximum eligible household income to rent an ADU for each rental ADU price tier is calculated as follows:
    - i. The Median Family Income (MFI) for the Boston-Cambridge- Quincy, MA-NH HUD Metro FMR Area published annually by the U.S Department of Housing and Urban Development (HUD) is multiplied by the percentage specified on Table 12.1.5 (a) for the price tier and potential household size for the specific unit available to determine the maximum annual income permitted for a

**Table 12.1.5 (b) Rental ADU Price Multiplier**

ADU Tier	Bedroom Count								
	Studio	1	2	3	4	5	6	7	8
Tier 1: "Very Low Income"	7.14%	8.40%	9.60%	10.80%	12.00%	13.20%	14.40%	15.60%	16.80%
Tier 2: "Low Income"	12.50%	14.70%	16.80%	18.90%	21.00%	23.10%	25.20%	27.30%	29.40%
Tier 3: "Moderate Income"	17.85%	21.00%	24.00%	27.00%	30.00%	33.00%	36.00%	39.00%	42.00%

**Table 12.1.5 (c) Ownership ADU Price Multiplier**

ADU Tier	Bedroom Count								
	Studio	1	2	3	4	5	6	7	8
Tier 1: "Low Income"	11.76%	13.72%	15.68%	17.64%	19.60%	21.56%	23.52%	25.48%	27.44%
Tier 2: "Moderate Income"	16.66%	19.60%	22.40%	25.20%	28.00%	30.80%	33.60%	36.40%	39.20%
Tier 3: "Middle Income"	21.66%	25.48%	29.12%	32.76%	36.40%	40.04%	43.68%	47.32%	50.96%



## 12. DEVELOPMENT BENEFITS

Affordable Housing

- household to qualify to lease the unit.
- c. The maximum eligible household income to purchase an ADU for each ownership ADU price tier is calculated as follows:
    - i. The Median Family Income (MFI) for the Boston-Cambridge- Quincy, MA-NH HUD Metro FMR Area published annually by the U.S Department of Housing and Urban Development (HUD) is multiplied by the percentage specified on Table 12.1.5 (b) for the price tier and potential household size for the specific unit available to determine the maximum annual income permitted for a household to qualify to purchase the unit.
  - d. The selection of specific households to rent or purchase an ADUs is subject to a selection system administered by the City of Somerville. Households selected must meet the income eligibility requirements of this section, and any other certification requirements established by the Director of Housing, at the time of any purchase or the execution of any lease agreement.
  - e. The City of Somerville, or its designee reserves the right of first refusal and option to purchase ADUs at the time of the sale or any subsequent resale.
  - f. The review boards may require for-sale ADUs to be sold to the City at a price per unit set per §12.1.4.d as a condition of Discretionary or administrative permit approval. The City may subsequently sell or rent these ADUs at an equivalent or lower price than required by this Section.
  - g. Except as provided in 12.1.6.e and 12.1.f, ADUs established in accordance with this Section must be rented or sold only to eligible households for as long as the BUILDING containing the ADUs exists.
7. **ADU Development Standards**
    - a. Unless otherwise specified elsewhere in this Ordinance, ADUs must be provided on-site, intermixed with the MARKET RATE UNITS in the DEVELOPMENT that generated the requirement for AFFORDABLE DWELLING UNITS. ADUs may not be overly concentrated on any single STORY of a BUILDING without the approval of the Director of Housing.
    - b. ADUs must be proportional to the corresponding MARKET RATE UNITS with respect to tenure type (for-sale or rental), unit size, number of bedrooms, and size of rooms. The proportion of ADUs with two (2) or more bedrooms may exceed the proportion provided for the corresponding MARKET RATE UNITS for each tenure type.
    - c. Unless otherwise specified elsewhere in this Ordinance, any DEVELOPMENT with thirty (30) or more DWELLING UNITS must provide at least twenty percent (20%) of the ADUs with three (3) or more bedrooms. Any fractional number resulting from this calculation is rounded up to the next whole number and regarded as a whole unit.
      - i. The Director of Housing shall establish quality standards for three (3) BEDROOM ADUs. Quality standards must include, but may not be limited to, minimum floor area and the inclusion of certain features such as the number of bathrooms and the existence of built-in closets.
      - ii. The review boards shall require compliance to the quality standards for three (3) BEDROOM ADUs as a condition of Discretionary or administrative permit approval.
    - d. Unit features including, but not limited to, finishes, appliances, and outdoor amenity spaces must be

**Table 12.1.6 (a) Income Multiplier for Rental ADUs**

ADU Tier	Household Size								
	Studio	1	2	3	4	5	6	7	8
Tier 1: "Very Low Income"	30%	35%	40%	45%	50%	55%	60%	65%	70%
Tier 2: "Low Income"	48%	56%	64%	72%	80%	88%	96%	104%	112%
Tier 3: "Moderate Income"	65%	77%	88%	99%	110%	121%	132%	143%	154%

**Table 12.1.6 (b) Income Multiplier for Ownership ADUs**

ADU Tier	Household Size								
	Studio	1	2	3	4	5	6	7	8
Tier 1: "Low Income"	48%	56%	64%	72%	80%	88%	96%	104%	112%
Tier 2: "Moderate Income"	65%	77%	88%	99%	110%	110%	132%	143%	154%
Tier 3: "Middle Income"	83%	98%	112%	126%	140%	140%	168%	182%	196%

## 12. DEVELOPMENT BENEFITS

### Affordable Housing

comparable to those provided in corresponding market-rate units, but may be functionally equivalent rather than identical provided that they are durable, of good quality, and consistent with contemporary standards for new housing with the approval of the Director of Housing.

- e. Unless otherwise specified elsewhere in this Ordinance, ADUs must have the same ACCESS to amenities that are provided to the corresponding market-rate units including, but not limited to, laundry facilities, storage, fitness rooms, parking, and shared outdoor amenity spaces.

#### 8. Implementation Plans and Covenants

- a. An Affordable Housing Implementation Plan (AHIP) is required for all DEVELOPMENT subject this Section.
  - i. The Director of Housing shall establish submittal requirements for AHIPs. Required information must include, but may not be limited to, the following:
    - a). Housing statistics including the total number of DWELLING UNITS in the BUILDING; the number of MARKET RATE UNITS by BEDROOM COUNT with average floor area for each; the unit number, floor area, BEDROOM count; and the unit number, floor area, BEDROOM count, interior amenities, outdoor amenity spaces, accessibility features and the price tier for each ADU.
    - b). Floor plans indicating the location of each ADU.
    - c). An ACCESS map indicating the location of all site amenities.
    - d). Any agreements required of the APPLICANT deemed to be necessary by the Director of Housing to ensure compliance to the provisions of this Section.
  - ii. The Director of Housing may, at their discretion, require PROPERTY OWNERS of rental ADUs to submit an annual report detailing ongoing compliance with this section as a requirement of an AHIP.
  - iii. Development review applications are not considered complete unless a preliminary AHIP been submitted to the Director of Housing for information purposes.
- b. The review boards shall require Applicants to execute and record a deed restriction limiting the sale or rental of ADUs to eligible households in perpetuity with the Middlesex South Registry of Deeds, or filed with the Land Registration Office, and submit a final AHIP to the Director of Housing for approval as a condition of any Discretionary or administrative permit approval.
- c. The BUILDING OFFICIAL will not issue a BUILDING Permit for DEVELOPMENT subject to this Section until a final AHIP has been approved by the Director of Housing.
- d. The BUILDING OFFICIAL will not issue any Certificate of

Occupancy for DEVELOPMENT subject to this Section until a deed restriction limiting the sale or rental of ADUs to eligible households is executed and recorded with the Middlesex South Registry of Deeds or filed with the Land Registration Office.

- i. The affordable housing covenant must be in a form approved by the City Solicitor.

#### 9. Buyouts & Payments

- a. Fractional Buyouts
  - i. The fractional buyout for an ownership or rental ADU is calculated as  $(A*B)$  where:
    - a). A is the amount of ADUs not provided; and
    - b). B is the difference between the average sales price of comparable market-rate units sold within the city of Somerville over the previous twelve (12) months and the sale price of an ADU in the ownership or rental price tier that would have been provided, as calculated according to §12.1.4 ADU Price.
- b. In-Lieu Payments
  - i. Applicants may request to make a payment to the City in lieu of providing one (1) or more required ADUs by Special Permit.
    - a). In addition to the review criteria for all Special Permits specified in §15.2.1.e. Review Criteria, the review board shall make findings considering the following in its discretion to approve or deny a special permit authorizing a payment in lieu of ADUs:
      - i). If receipt of an in-lieu payment is advantageous to the City in creating or preserving affordable housing as compared to the ADUs that would have been otherwise provided.
  - ii. The in-lieu payment for an ownership ADU is calculated as  $2*(A*B)$  where:
    - a). A is the amount of ADUs not provided; and
    - b). B is the difference between the average sales price of comparable market-rate units sold within the city of Somerville over the previous twelve (12) months and the sale price of an ADU in the ownership or rental price tier that would have been provided, as calculated according to §12.1.4 ADU Price.
  - iii. The in-lieu payment for a rental ADU is calculated as  $2.5*(A*B)$  where:
    - a). A is the amount of ADUs not provided; and
    - b). B is the difference between the average sales price of comparable market-rate units sold within the city of Somerville over the previous twelve (12) months and the sale price of an ADU in the ownership or rental price tier that would have been provided, as calculated

according to §12.1.4 ADU Price.

- c. Receipt of Buyouts & Payments
  - i. Buyouts and in-lieu payments must be paid to the Somerville Affordable Housing Trust Fund or, alternatively, to the City of Somerville for transfer to a Massachusetts Non-Profit Housing Finance Corporation, at the discretion of the Director of Housing.
- d. The BUILDING OFFICIAL shall not issue a Certificate of Occupancy for DEVELOPMENT until any authorized fractional buyout or in-lieu payment has been made in accordance with this Section.

### 10. Compliance

- a. Certificate of Occupancy
  - i. Unless otherwise specified elsewhere in this Ordinance, the BUILDING OFFICIAL may not issue a Certificate of Occupancy for any MARKET RATE UNITS of DEVELOPMENT subject to the provisions of this Section until:
    - a). A proportional number of the required ADUs, including any off-site ADUs, have obtained Certificates of Occupancy; and
    - b). Payment for any fractional buyout required by this Section has been made to the Somerville Affordable Housing Trust Fund.
- b. Annual Reporting
  - i. PROPERTY OWNERS must submit an annual report to validate continued compliance with the provisions of this Section in accordance with the standards established by the Director of Housing.
- c. Fines & Penalties
  - i. In accordance with §1.1.7. Fines & Penalties, the BUILDING OFFICIAL shall consider each day as a separate offense for DEVELOPMENT that is not in compliance with the provisions of this Section.
  - ii. Fines must be paid to the Somerville Affordable Housing Trust Fund.

### 11. Performance Review

- a. The Director of Housing shall undertake a Needs Assessment and Financial Feasibility Analysis to determine the suitability and performance of the provisions of this section for potential revision and improvement prior to January 31, 2021 and then not less than every three (3) years thereafter.
- b. The Mayor shall submit recommended changes to the provisions of this section to the City Council for consideration.

# 12. DEVELOPMENT BENEFITS

## Linkage

### 12.2 LINKAGE

#### 1. Applicability

- a. Unless otherwise specified, this Section is applicable to building types as specified in Article 3: Residential Districts, Article 4: Mid-Rise Districts, Article 5: High-Rise Districts, Article 7: Special Districts, and Article 8: Overlay Districts.
- b. DEVELOPMENT may not be segmented or phased in any manner and APPLICANTS may not establish surrogate or subsidiary entities to avoid compliance with this Section.

#### 2. Affordable Housing Linkage

##### a. Purpose

- i. To mitigate the impact of the increased demand for housing generated by employees of new commercial DEVELOPMENT wanting to live within Somerville.
- ii. To support the DEVELOPMENT of affordable housing that is available to qualifying households over the long-term.
- iii. To recapture a public benefit from the increased value of land resulting from the adoption of this Ordinance.

##### b. Applicability

- i. This section is applicable to all non-residential DEVELOPMENT, except the following:
  - a). Real property owned by the City of Somerville
  - b). Religious & Educational uses protected by M.G.L. 40A. Sec. 3
  - c). CREATIVE STUDIOS
  - d). Accessory Vehicular Parking

##### c. Fees

###### i. General

- a). All applicable DEVELOPMENT must pay an affordable housing linkage fee of ten dollars (\$10) per gross square foot, except as follows:
  - i). DEVELOPMENT with less than thirty thousand (30,000) gross square feet is exempt.
  - ii). The first thirty thousand (30,000) gross square feet of DEVELOPMENT that has more than thirty thousand (30,000) gross square feet in total is exempt.
- b). MODIFICATIONS to an existing STRUCTURE that increases the total GROSS FLOOR AREA to more than thirty thousand (30,000) gross square feet must pay the affordable housing linkage fee for the additional square footage.

###### ii. Inflation Adjustment

- a). The affordable housing linkage fee is adjusted for inflation annually, beginning on March 1, 2019, based on the change in the Boston Consumer Price Index. The Director of Housing

shall publish and annually update the adjusted housing linkage fee on the City website.

##### iii. Payment

- a). Affordable housing linkage fees must be paid to the Somerville Affordable Housing Trust Fund, in three (3) equal annual installments.
- b). The BUILDING OFFICIAL may not issue a Certificate of Occupancy for real property that has not paid the first installment of the affordable housing linkage fee.
- c). Affordable housing linkage fee payments must be paid annually on the anniversary of the first payment, or the next business day if that date falls on a weekend or federal, state, or local holiday.

##### d. Compliance

- i. The review boards shall require Applicants to execute and record a covenant or deed restriction agreeing to pay the housing linkage fee with the Middlesex South Registry of Deeds or filed with the Land Registration Office as a condition of any Discretionary of Administrative permit approval.
- ii. The BUILDING OFFICIAL may not issue any Certificate of Occupancy for DEVELOPMENT subject to this Section until a covenant or deed restriction agreeing to pay the housing linkage fee is executed and recorded with the Middlesex South Registry of Deeds or filed with the Land Registration Office.

##### e. Enforcement

- i. In accordance with §1.1.7. Fines & Penalties, the BUILDING OFFICIAL shall consider each day as a separate offense for DEVELOPMENT that is not in compliance with the provisions of this Section.
- ii. Fines must be paid to the Somerville Affordable Housing Trust Fund.

##### f. Formula Recalculation

- i. The Planning Board shall prepare a Nexus Study every five (5) years to determine the suitability and performance of the provisions of this section and recommend any possible revisions or improvements necessary to address changing demand for affordable housing to the City Council.

#### 3. Employment Linkage

##### a. Purpose

- i. To create and maintain employment opportunities within the city of Somerville for the residents of Somerville.
- ii. To mitigate the impact of large-scale DEVELOPMENTS on the cost of housing.
- iii. To provide training and services that will enable residents to ACCESS employment opportunities that will permit them to succeed and maintain adequate incomes to continue to afford living in Somerville.

- iv. To expand resident ACCESS to employment opportunities provided by new commercial DEVELOPMENT.
  - v. To recapture a public benefit from the increased value of land resulting from the adoption of this Ordinance.
  - b. Applicability
    - i. This section is applicable to all commercial DEVELOPMENT requiring site DEVELOPMENT plan approval or a special permit, except the following:
      - a). Real property owned by the City of Somerville
      - b). Religious & Educational uses protected by M.G.L. 40A. Sec. 3
      - c). CREATIVE STUDIOS
      - d). Accessory Vehicular Parking
  - c. Fees
    - i. General
      - a). All applicable DEVELOPMENT must pay a job creation and retention linkage fee (hereafter referred to as “jobs linkage fee”) of two dollars and forty-six cents (\$2.46) per gross square foot, except as follows:
        - i). DEVELOPMENT with less than fifteen thousand (15,000) gross square feet is exempt.
        - ii). The first fifteen thousand (15,000) gross square feet of DEVELOPMENT that has more than fifteen thousand (15,000) gross square feet in total is exempt.
      - b). MODIFICATIONS to an existing STRUCTURE that increases the total GROSS FLOOR AREA to more than fifteen thousand (15,000) gross square feet must pay the jobs linkage fee for the additional square footage.
    - ii. Inflation Adjustment
      - a). The jobs linkage fee is adjusted for inflation annually, beginning on March 1, 2019, based on the change in the Boston Consumer Price Index. The Director of Housing shall publish and annually update the adjusted jobs linkage fee on the City website.
    - iii. Payment
      - a). Jobs linkage fees must be paid to the Somerville Municipal Job Creation and Retention Trust Fund, in two (2) equal installments.
      - b). The BUILDING OFFICIAL will not issue a BUILDING Permit for DEVELOPMENT, beyond foundation construction, until the first installment of the jobs linkage is paid.
      - c). The BUILDING OFFICIAL will not issue a Certificate of Occupancy for DEVELOPMENT until the second installment of the jobs linkage fee has been paid.
  - d. Compliance
    - i. The review boards shall require Applicants to execute and record a covenant or deed restriction agreeing to pay the jobs linkage fee with the Middlesex South Registry of Deeds or filed with the Land Registration Office as a condition of any Discretionary of Administrative permit approval.
    - ii. The BUILDING OFFICIAL will not issue any Certificate of Occupancy for DEVELOPMENT subject to this Section until a covenant or deed restriction agreeing to pay the jobs linkage fee is executed and recorded with the Middlesex South Registry of Deeds or filed with the Land Registration Office.
  - e. Enforcement
    - i. In accordance with §1.1.7. Fines & Penalties, the BUILDING OFFICIAL shall consider each day as a separate offense for DEVELOPMENT that is not in compliance with the provisions of this Section.
    - ii. Fines must be paid to the Somerville Municipal Job Creation and Retention Trust Fund.
  - f. Formula Recalculation
    - i. The Planning Board shall prepare a Nexus Study every five (5) years to determine the suitability and performance of the provisions of this section and recommend any possible revisions or improvements necessary to address changing need for job training to the City Council.
- 4. Green Line Linkage**
    - a. Reserved
  - 5. Civic Space Linkage**
    - a. Reserved
  - 6. Performance Review**
    - a. The Mayor shall undertake a Needs Assessment and Financial Feasibility Analysis every five (5) years after the adoption date of this Ordinance to determine the suitability and performance of the provisions of this Section and to recommend any possible revisions or improvements necessary to achieve the stated purpose of the established linkage requirements.
    - b. The Mayor shall submit recommended changes to the provisions of this section to the City Council for consideration.

# 12. DEVELOPMENT BENEFITS

Linkage



# 13 PUBLIC REALM

<b>13.1 CIVIC SPACE .....</b>	<b>499</b>
Development Review	499
Standards for All Civic Spaces	499
Parks	501
Commons	506
Plazas	509
Civic Uses	514
<b>13.2 THOROUGHFARES .....</b>	<b>519</b>
Development Review	519
Standards for all Thoroughfare Type	519
Standards for Specific Thoroughfare Types	519
Sidewalks	519
Mid-Block Passages	521

## 13. PUBLIC REALM

## 13.1 CIVIC SPACE

### 1. Development Review

- a. The DEVELOPMENT of any CIVIC SPACE requires Site Plan Approval followed by a Civic Space Permit, in accordance with Chapter 15: Administration, and is exempt from Chapter 11, Article II, Sec. 11-33 (b) of The Code of Ordinances, City of Somerville, Massachusetts.
- b. All DEVELOPMENT, excluding NORMAL MAINTENANCE, requires the submittal of a development review application to the BUILDING OFFICIAL and the issuance of a Certificate of Zoning Compliance prior to the issuance of a Civic Space Permit.

### 2. Standards for All Civic Spaces

- a. Siting & Orientation
  - i. CIVIC SPACES must be SITED and oriented to maximize their inherent exposure to the sun as follows:
    - a). CIVIC SPACES are prohibited on LOTS that have only one (1) NORTH-FACING, west-facing, or east-facing FRONT LOT LINE.
- b. Design & Construction
  - i. CIVIC SPACES must be engineered and constructed as required by the Director of Public Space & Urban Forestry, in consultation with the City Engineer.
- c. Accessibility
  - i. The design of all CIVIC SPACE must comply with the Americans with Disabilities Act and the Rules and Regulations of the Massachusetts ACCESS Board (521 CMR), as amended.
  - ii. Sloping walkways are encouraged over ramps when reasonably possible to provide for ACCESSIBLE grade changes.
- d. Hours of ACCESS
  - i. CIVIC SPACES must be ACCESSIBLE to the public at all times (twenty four (24) hours per day, seven (7) days per week, three hundred and sixty-five (365) days per year).
  - ii. The review boards may limit the hours of public ACCESS when necessary for public health and safety purposes and maintenance of the space by the PROPERTY OWNER as a condition of Site Plan Approval.
- e. Circulation
  - i. Entrances must be physically and visually ACCESSIBLE from surrounding SITES, designed to make visitors feel welcome and comfortable entering the space, and oriented to preserve view corridors and enhance visual connections to surrounding properties or activities.
  - ii. Entrances adjacent to children's activity areas must be gated.
- f. Landscape
  - i. All landscaping within CIVIC SPACES must comply with the provisions of Section 10.4 Landscaping.
- ii. LARGE TREES are required as indicated for each type of CIVIC SPACE.
- iii. Unless otherwise specified, trees must be planted flush-to-grade or at grade within PLANTING BEDS. Tree grates, raised curbs, railings, and resin-bonded aggregate are prohibited.
- iv. At least one thousand (1,000) cubic feet of SOIL VOLUME must be provided for each tree within a twenty seven (27) foot radius of the tree trunk.
  - a). Where SOIL VOLUMES within the maximum allowable radii for adjacent trees overlap, up to twenty-five percent (25%) of the required for each tree may be shared between trees.
  - b). SOIL VOLUME provided under paved surfaces must be provided through SUSPENDED PAVEMENTS OR STRUCTURAL CELLS. SAND-BASED STRUCTURAL SOIL SYSTEM (SBSS) may be USED with approval of the Director of Public Space & Urban Forestry.
- v. TREE PITS and PLANTERS must have a minimum thirty-six (36) sq. ft. (such as 6'x6') open soil area, centered at the tree trunk. Planting soil must be provided to a depth of three (3) feet in the TREE PIT OR PLANTER.
- vi. Unless otherwise specified, shredded bark mulch must be applied to the soil area at a uniform depth of three (3) inches and distributed to create a smooth, level cover over the exposed soil at the time of planting.
- g. Hardscape
  - i. Surface materials must be approved by the Director of Public Space & Urban Forestry.
  - ii. Pervious surfaces may be provided above underground parking and any required cap/fill over contaminated soils, but must be constructed as required by the City Engineer and the Director of Public Space & Urban Forestry.
- h. Amenities and Furnishings
  - i. All amenities and public furniture must comply with the City of Somerville's Park Specifications Handbook. The Director of Public Space & Urban Forestry may authorize the USE of amenities and furnishings that are proportional or better in quality and function to those identified in the Park Specifications Handbook, excluding dedication plaques and SIGNAGE.
- i. Seating
  - i. Seating is required as indicated for each type of CIVIC SPACE. The provision of seating in excess of this requirement is encouraged.
  - ii. Seating must be designed for the convenience and comfort of visitors, located in support of gathering spaces and along pedestrian paths, but should be out of the flow of pedestrian traffic.

# 13. PUBLIC REALM

## Civic Space

- iii. When required to provide seating, CIVIC SPACES should offer a variety of seating types and seating locations including places to sit in the sun, in the shade, out of the wind, in groups, alone, close to activity, and in relative seclusion to every extent possible.
- iv. Linear feet of seating may be provided through movable chairs, fixed individual seats, fixed benches with or without backs, seat walls, PLANTER and fountain ledges, and/or seating steps.
- v. Seat walls, PLANTER and fountain ledges, and/or seating steps may not, in aggregate, represent more than fifteen percent (15%) percent of the linear feet of required seating.
- vi. All seating must have a minimum seat depth of eighteen (18) inches and a seat height between sixteen (16) inches minimum and twenty (20) inches maximum above grade (adjacent walking surfaces).
- vii. Seating thirty (30) inches or more in depth is counted as double the linear feet, provided there is ACCESS to both sides.
- viii. PLANTER or fountain ledges provided as seating must have a minimum depth of twenty two (22) inches.
- ix. Seat backs must be a minimum of fourteen (14) inches high and either contoured in form for comfort or reclined between ten (10) to fifteen (15) degrees from vertical. Walls located adjacent to a seating surface do not count as seat backs.
- x. Movable chairs are not permitted to be chained, fixed, or otherwise secured while a CIVIC SPACE is open to the public, however may be chained or removed during the hours of 9:00pm to 7:00am.
- xi. Steps provided for pedestrian circulation and the seating of open air café areas do not count toward seating requirements.
- xii. Deterrents to seating, such as spikes, rails, or deliberately uncomfortable materials or shapes, placed on surfaces that would otherwise be suitable for seating are prohibited.
- xiii. Deterrents to skateboards, rollerblades and other wheeled devices are permitted on seating surfaces if they do not inhibit seating, maintain a minimum distance of five feet between deterrents, and are integrated into the seating surface at the time of manufacture or construction.
- j. Tables
  - i. Tables are required as indicated for each type of CIVIC SPACE. The provision of tables in excess of this requirements is permitted.
  - ii. All CIVIC SPACES requiring tables must include a minimum of one handicapped ACCESSIBLE table.
- k. Bicycle Parking
  - i. Bicycle parking must be provided as required by Director of Public Space & Urban Forestry and is subject to provisions of §12.1 Bicycle Parking.
- l. SIGNAGE
  - i. Permanent SIGNAGE must be provided as appropriate for each type of CIVIC SPACE.
  - ii. SIGNAGE should be located at entrances and at significant locations to provide direction and information for visitors and residents.
- m. Litter Receptacles
  - i. Litter receptacles must be designed in such a manner that USERS do not have to touch the receptacle or push open a door in order to dispose of litter.
  - ii. Litter receptacles must be constructed of durable materials that are graffiti-, fire-, rust, and stain-resistant.
  - iii. Litter receptacles must include a metal barrier to prevent rodents from entering from the bottom.
  - iv. Litter receptacles should be located near entrances to CIVIC SPACES and within reasonable proximity to seating areas.
  - v. Recycling receptacles are required in conjunction with litter receptacles.
- n. Lighting
  - i. Lighting that promotes personal safety and invites pedestrian activity while adding visual ambiance and character to civic and recreation spaces at night must be provided.
  - ii. Lighting fixtures should be smaller-scale, frequently placed, and scaled to pedestrians. Fixture components (base, pole, luminaries) should have stylistic compatibility, while varying in form according to functional requirements. The indiscriminate USE of bright lighting should be limited.
- o. Irrigation & Drainage
  - i. All irrigation systems must be designed to USE a minimal amount of water.
  - ii. Drainage systems must be designed to return drain water to the soil.
  - iii. All water holding and infiltration facilities must be designed to meet the specific needs of each type of CIVIC SPACE.
- p. ACCESSORY STRUCTURES
  - i. ACCESSORY STRUCTURES common to CIVIC SPACES, including but not limited to, restrooms, open-air pavilions, gazebos, picnic shelters, outdoor theaters/performance stages, field houses, and their substantial equivalents are permitted.

**3. Parks**

a. A PARK is a CIVIC SPACE type designed for active and passive recreation, with its character defined by the uses and features provided to meet the needs of different user groups. There are four subtypes of parks: a Regional Park, a Community Park, a Neighborhood Park, and a Pocket Park.



Lot Dimensions		
Lot Size (min/max)	--	--
Regional Park	10 acres	N/A
Community Park	2 acres	10 acres
Neighborhood Park	8,000 sf	2 acres
Pocket Park	800 sf	10,000 sf

Vegetation	
LARGE TREES (min)	--
Regional Park	1 / 1,225 sf
Community Park	1 / 1,225 sf
Neighborhood Park	1 / 1,225 sf
Pocket Park	1 / 400 sf

Lot Development		
Landscaped Area (min/max)	--	--
Regional Park	75%	100%
Community Park	75%	100%
Neighborhood Park	50%	100%
Pocket Park	70%	100%
PERVIOUS AREA (min)	--	--
Regional Park	85%	
Community Park	85%	
Neighborhood Park	85%	
Pocket Park	85%	

Furnishings	
Seating (min)	--
Regional Park	N/A
Community Park	N/A
Neighborhood Park	N/A
Pocket Park	1 linear foot / 75 sf.
Tables (min)	--
Regional Park	N/A
Community Park	N/A
Neighborhood Park	N/A
Pocket Park	N/A



# 13. PUBLIC REALM

## Civic Space

- b. General to all Parks
  - i. DEVELOPMENT Standards
    - a). All parks must provide varied spaces that accommodate a wide range of ages, physical abilities, and programming.
    - b). All parks must have at least one (1) entrance point from each ABUTTING THOROUGHFARE to encourage ACCESS from the surrounding neighborhood and from public transportation routes.
    - c). Trees must be planted to provide shade during summer months, especially in seating areas and playgrounds.
    - d). A minimum of one (1) compacting combination litter/recycling receptacle is required for every ten thousand (10,000) square feet of park area.
    - e). Landscaping must consist of informally arranged trees and SHRUBS. The topography may be irregular.
  - ii. Design Guidelines
    - a). Entrances should be well designed to make visitors feel welcome and comfortable entering the space.
- c. Regional Parks
  - i. DEVELOPMENT Standards
    - a). A regional park must include a well-connected network of paths that effectively accommodates a variety of travel modes, including walking, bicycling, and provisions to ACCESS by maintenance vehicles.
    - b). One (1) highly-visible and distinct entryway, entrance marker, or gateway is required on each side of a regional park.
  - ii. Design Guidelines
    - a). Park features should allow for a diverse group of USERS to participate in various recreation activities simultaneously.
    - b). ACCESSORY STRUCTURES should stylistically reflect the SITE furnishings and be constructed of quality materials that can withstand heavy USE.
    - c). Pathways should create ANTICIPATION and visual interest by framing views and directing attention to landscape features.
    - d). Regional parks should provide deliberate focal points along all park routes and at all park destinations.
      - i). Trees should be used in an informal manner to spatially define primary USER spaces and to frame views sheds.
- d. Community Parks
  - i. DEVELOPMENT Standards
    - a). A Community Park must provide varied spaces that accommodate a wide range of ages, physical abilities and programming.
    - b). A Community Park must have multiple entrance points to encourage ACCESS from the





surrounding neighborhood and from public transportation routes.

ii. Design Guidelines

- a). Approximately two-thirds of a community park should be reserved for active recreation uses such as: playgrounds, sports fields or courts, areas for free play or physical fitness or activities.
- b). Varied play environments that foster the development of children’s cognitive, physical and social development are encouraged.
- c). Water features and changes in topography are encouraged.
- d). Amenities and furnishings include, but are not limited to: seating, drinking fountains, picnic tables and benches, litter receptacles. Signage should be placed at entrances or other points where people gather.
- e). In addition to active physical recreation, Community Parks should provide opportunities for public art, performance space and community engagement in artistic and cultural expression.
- f). Trees should be planted to provide shade during summer months, especially in seating areas and playgrounds.

e. Neighborhood Parks

i. Development Standards

- a). A Neighborhood Park must provide varied spaces that accommodate a wide range of ages, physical abilities and programming.
- b). A Neighborhood Park must have multiple

entrance points to encourage access from the surrounding neighborhood and from public transportation routes.

- c). Trees must be planted to provide shade during summer months, especially in seating areas and playgrounds.

ii. Design Guidelines

- a). Connectivity to the surrounding environment in a Neighborhood Park is vital. Sidewalks, bike paths, crosswalks and connections to larger transportation systems should be established and clear.
- b). Wherever possible, spaces should be multi-use and flexible to accommodate as many different uses as possible.
- c). Spaces in a Neighborhood Park should reflect the desires of the surrounding residents and provide programming that is relevant to that neighborhood’s demographic and user groups.
- d). Varied play environments that foster the development of children’s cognitive, physical and social development are encouraged.
- e). Water features and changes in topography are encouraged.
- f). Amenities and furnishings may include, but are not limited to: seating, drinking fountains, tables, chairs and benches, moveable tables and chairs, litter receptacles, etc. Signage should be placed at entrances or other points where people gather.
- g). Fencing and vegetation should preserve privacy for abutting yards while providing



# 13. PUBLIC REALM

## Civic Space

resident visibility into the park.

- h). In addition to active physical recreation, Neighborhood Parks should provide opportunities for public art, performance space and community engagement in artistic and cultural expression. Public art and performances should reflect the neighborhood and preserve a sense of neighborhood identity.
  - i). A neighborhood park should offer a variety of seating types and seating locations, including places to sit in the sun, in the shade, out of the wind, in groups, alone, close to activity, and in relative seclusion to every extent possible.
- f. Pocket Parks
- i. DEVELOPMENT Standards
    - a). A small seating area must be provided at the entrance of a pocket park to allow users to casually watch passing pedestrians without fully entering the park.
    - b). The STREET-side boundary of a pocket park must include a well-defined entry and provide unobstructed views of what activities and facilities are available within the space, but also provide a sense of enclosure for users inside.
    - c). In residential areas, active or useable portions of a pocket park must be adequately screened for privacy from adjacent residential properties through the use of keep-off GROUNDCOVERS, SHRUB plantings, or fencing.
    - d). In non-residential areas, active or useable portions of a pocket park must extend to the LOT LINES and views into the park maintained to promote casual surveillance.
  - ii. Design Guidelines
    - a). Pocket parks should be designed in consideration of the wide range of ages and habits of the people who may use the space at different times of day or night, with primary concern of the potential users living or working within a five (5) minute walk whom most need recreation space.
    - b). A community bulletin board should be included near the entrance to the pocket park.
    - c). The entrance to the pocket park should be emphasized through special planting, paving, seating, or other design elements that draw attention.
    - d). Paved surfaces should be paved with darker colored paving material(s). The use of concrete should be minimized to reduce glare.
    - e). If ABUTTING properties have first floor windows that would benefit from light and a filtered view, chain link perimeter fencing and fast growing vines should be used instead of any



solid fence materials.

- f). In non-residential areas, the exterior walls of surrounding buildings should be capitalized on where possible.
- g). Trees should be deciduous and of a species that can tolerate being climbed by children.
- h). Plantings should be fast growing, resilient, easily maintained, and not poisonous.
- i). Nighttime lighting should be sensitive to ABUTTING USES.



# 13. PUBLIC REALM

## Civic Space

### 4. Commons

- a. A Common is CIVIC SPACE type designed for passive recreation and civic purposes, with its character defined primarily by vegetation. There are three subtypes of commons: a Public Common, a Public Square, and a Green. Public Commons and Public Squares are often designed to also support active recreation.



Lot Dimensions		
Lot Size (min/max)	--	--
Public Common	20,000 sf	8 acres
Public Square	10,000 sf	2 acres
Green	6,000 sf	1 acre

Vegetation	
LARGE TREES (min)	--
Public Common	1 / 1,225 sf
Public Square	1 / 1,225 sf
Green	1 / 1,225 sf

Lot Development		
Landscaped Area (min/max)	--	--
Public Common	80%	100%
Public Square	50%	100%
Green	75%	100%
PERVIOUS AREA (min)	--	--
Public Common	85%	
Public Square	85%	
Green	85%	

Furnishings	
Seating (min)	--
Public Common	1 linear foot / 100 sf.
Public Square	1 linear foot / 75 sf.
Green	1 linear foot / 75 sf.
Tables (min)	--
Public Common	N/A
Public Square	N/A
Green	N/A



- b. General to All Commons
  - i. DEVELOPMENT Standards
    - a). A minimum of one (1) compacting combination litter/recycling receptacle is required for every ten thousand (10,000) square feet.
  - ii. Design Guidelines
    - a). Reserved
- c. Public Commons
  - i. DEVELOPMENT Standards
    - a). Reserved
  - ii. Design Guidelines
    - a). A PUBLIC COMMON should provide a substantially sized and uninterrupted OPEN SPACE that is landscaped with smooth GROUNDCOVERS, LARGE TREES, and little to no understory plants. Both paved and unpaved paths may be provided, as well as a substantial water feature.
    - b). Large canopy trees should be USED in an informal manner to spatially define the perimeter while also framing views of neighboring buildings from within the PUBLIC COMMON.
    - c). A PUBLIC COMMON should be designed to promote options for children to engage in different forms of play; provide locations where sports, picnics, special events, and simple relaxation can occur for adults; and may include areas designed specifically to accommodate the activities of a public market.
    - d). Paths should provide a variety of walking/running circuits within the PUBLIC COMMON, accommodate DESIRE LINES to surrounding USES on neighboring BLOCKS, and provide different sensory experiences along their edge that change over time and vary across the PUBLIC COMMON.
    - e). Entrances should be well designed to make visitors feel welcome and comfortable entering the space, be physically and visually ACCESSIBLE from surrounding BLOCKS, and include areas for congregating in groups.
- d. Public Squares
  - i. DEVELOPMENT Standards
    - a). A minimum of one (1) linear foot of required seating for every twenty (20) linear feet of STREET frontage must be located within the FRONTAGE AREA of a public square.
  - ii. Design Guidelines
    - a). A PUBLIC SQUARE should have design characteristics in response to the surrounding civic, commercial, and residential context of surrounding buildings.
    - b). LARGE TREES should be USED to establish the perimeter of the public square.
- e. Greens
  - i. DEVELOPMENT Standards
    - a). A green must ABUT at least one public THOROUGHFARE and one private LOT.
    - b). The first fifteen (15) feet of a Green measured perpendicularly from any FRONT LOT LINE is considered the FRONTAGE AREA. A minimum of one (1) linear foot of required seating for every twenty (20) linear feet of STREET frontage must be located within the FRONTAGE AREA.



# 13. PUBLIC REALM

## Civic Space

- ii. Design Guidelines
  - a). LARGE TREES should provide shade for most of the area of the green.
  - b). Plantings should contribute to the spatial definition of the space as an outdoor room.
  - c). Open areas intended for passive use should be primarily planted with grass.
  - d). Benches and seating ledges or walls should be designed for the convenience and comfort of visitors, located in support of gathering spaces and along pedestrian circulation paths, but should be out of the flow of pedestrian traffic.





**5. Plazas**

a. A Plaza is a CIVIC SPACE type designed for passive recreation, civic purposes, and commercial activities, with its character defined primarily by hardscape. Plazas are generally located in activity centers or the nexus of major circulation routes. There are three subtypes of plaza: a Central Plaza, Through Block Plaza, and a Pocket Plaza.



Lot Dimensions		
Lot Size (min/max)	--	--
Central Plaza	8,000 sf	2 acres
Through Block Plaza	5,000 sf	10,000 sf
Pocket Plaza	2,000 sf	10,000 sf

Vegetation	
LARGE TREES (min)	--
Central Plaza	1 / 1,000 sf
Through Block Plaza	1 / 1,500 sf
Pocket Plaza	1 / 400 sf

Lot Development		
Landscaped Area (min/max)	--	--
Central Plaza	10%	30%
Through Block Plaza	10%	30%
Pocket Plaza	10%	30%
PERVIOUS AREA (min)	--	
Central Plaza	70%	
Through Block Plaza	70%	
Pocket Plaza	70%	

Furnishings	
Seating (min)	--
Central Plaza	1 linear foot / 30 sf.
Through Block Plaza	1 linear foot / 75 sf.
Pocket Plaza	1 linear foot / 50 sf.
Tables (min)	--
Central Plaza	1 / 4 movable chairs
Through Block Plaza	N/A
Pocket Plaza	1 / 3 movable chairs



# 13. PUBLIC REALM

## Civic Space

- b. General to all Plazas
  - i. DEVELOPMENT Standards
    - a). Contiguous LOTS designed as plazas are considered one single plaza.
    - b). A minimum of one (1) compacting combination litter/recycling receptacle is required for every five thousand (5,000) square feet of Pocket Plaza area.
  - ii. Design Guidelines
    - a). Reserved
- c. Central Plazas
  - i. DEVELOPMENT Standards
    - a). Plazas must be generally rectilinear in shape (e.g. rectangular or square).
    - b). The major portion of a public plaza is the area of a plaza that is largest in size and intended for primary use. Major portions must have a minimum average width and depth of forty (40) feet, a maximum width that is not greater than three (3) times the average depth, measured perpendicularly from the ABUTTING sidewalk, and occupy no less than seventy five percent (75%) of the plazas total area. All points within the major portion of a plaza must be visible when viewed perpendicularly from the sidewalk of the ABUTTING THOROUGHFARE.
    - c). Minor portions of a plaza are secondary areas that allow for additional flexibility in the shape and configuration of a plaza. Minor portions must have a minimum average width and depth of fifteen (15) feet, occupy no more than twenty five percent (25%) of the plazas total area, and be directly adjacent to the major portion. All points within a minor portion must be visible from within the major portion when viewed perpendicularly from the major portion. Minor portions that do not front onto the same THOROUGHFARE as the major portion (plaza alcoves) must have a maximum width that is not greater than three (3) times the average depth.
  - d). Visibility of major and minor portions of a plaza is not affected by permitted obstructions.
  - e). Plazas must be open to the sky and unobstructed for at least fifty percent (50%) of the area of a plaza except for the following features, equipment and appurtenances: bicycle racks; lighting; litter receptacles; PLANTERS, PLANTING BEDS, LAWNS, trees, and other landscape features; outdoor cafes and kiosks; public art; seating, including movable chairs, fixed individual seats, fixed benches, seat walls, PLANTER and fountain ledges, and/or seating steps; stages; temporary exhibitions; and water features.
    - i). Trees planted flush-to-grade and lawn, turf, or grass areas that do not differ in elevation from the surface of the plaza by more than six (6) inches are not considered obstructions.
    - ii). Obstructions that are non-permanent or moveable, such as moveable furniture, outdoor cafes, or temporary exhibitions are considered within gross areas designated





- on a SITE plan and not measured as individual pieces of furniture.
- iii). Approved BUILDING awnings, canopies, and SIGNS are exempt.
  - f). The first fifteen (15) feet of a plaza measured perpendicularly from any FRONT LOT LINE is considered the FRONTAGE AREA of a plaza.
  - g). To facilitate pedestrian ACCESS, at least fifty percent (50%) of the FRONTAGE AREA must be free from obstructions.
  - h). Pedestrian circulation paths within a plaza must provide for unobstructed circulation throughout the major and minor portions of the plaza and must, at minimum, connect any ABUTTING sidewalk or CIVIC SPACES to all major focal points and activity areas of the plaza and PRINCIPAL ENTRANCES of ABUTTING buildings. At least one circulation path of at least eight (8) feet clear width must be provided.
  - i). The surface of a plaza must be equal to the average elevation of the ABUTTING sidewalks, publicly ACCESSIBLE walkways, or other CIVIC SPACES. Minor changes beyond this elevation not exceeding two (2) feet are permitted. Plazas over ten thousand (10,000) square feet in area may have up to twenty percent (20%) of the plaza area elevated up to four (4) feet above the grade of the ABUTTING sidewalk, provided that the raised area is set back from the FRONT LOT LINE at least twenty (20) feet.
  - j). Paving must be of non-skid, durable materials that are decorative and compatible in color and pattern with other design features of the plaza.
  - k). Each plaza must provide at least two types of seating. Plazas over ten thousand (10,000) square feet in size must provide moveable seating as one of the required seating types.
  - l). A minimum of one (1) linear foot of required seating for every two (2) linear feet of plaza frontage must be located within the FRONTAGE AREA of a plaza. A minimum of fifty percent (50%) of this seating must have seat backs and at least fifty percent (50%) of the seating with seat backs must face the sidewalk.
  - m). Seat walls and seating steps may not, in aggregate, represent more than fifteen (15) percent of the linear feet of required seating.
  - n). Steps provided for pedestrian circulation must have a height (rise) between 4 to 6 inches and minimum tread (run) of 17 inches, except that steps with a height (rise) of 5 inches may have a minimum tread (run) of 15 inches.
  - o). Required open soil areas for trees may be reduced or covered with the approval of the Director of Public Space & Urban Forestry using one of the following techniques:
    - i). Soil area for trees planted flush-to-grade may be covered by cobblestones or other permeable PAVERS that can be removed to accommodate tree trunk and root growth over time. PAVERS must be installed level with the plaza surface and at minimum no closer than eighteen (18) inches from the tree trunk .



# 13. PUBLIC REALM

## Civic Space

- ii). Trees may be planted below the finished surface of a plaza and the soil area covered by a suspended PAVER grate system with a minimum twenty-four (24) inch wide tree opening and permeable PAVERS. Two- piece, removable trim rings are permitted to cover the tree opening.
- p). Plazas that contain outdoor cafes or kiosks providing food service must provide one (1) additional litter receptacle and (1) additional recycling receptacle for every one thousand five-hundred (1,500) square feet of plaza area occupied by such outdoor eating area.
- ii. Design Guidelines
  - a). A plaza should contain substantial areas of hardscape complemented by PLANTING BEDS or arrangements of trees with open canopies.
  - b). Plantings should contribute to the spatial definition of the space as an outdoor room.
  - c). Benches and seating ledges or walls should be designed for the convenience and comfort of visitors, located in support of gathering spaces and along pedestrian circulation paths, but should be out of the flow of pedestrian traffic.
  - d). The perimeter of a plaza should be well integrated into its surroundings and free from fences, hedges, and other barriers that would impede movement into the space and obscure visibility from adjacent STREETS or BUILDING frontages.
- d. Through BLOCK Plazas
  - i. DEVELOPMENT Standards
    - a). The first fifteen (15) feet of a through BLOCK plaza measured perpendicularly from any FRONT LOT LINE is considered the FRONTAGE AREA of a through BLOCK plaza and must be free from all obstructions.
    - b). The surface of a Through BLOCK Plaza must be equal to the average elevation of ABUTTING sidewalks or publicly ACCESSIBLE walkways.
    - c). Through BLOCK plazas must contain an unobstructed circulation path at least ten (10) feet in width, connecting the two THOROUGHFARES on which the through BLOCK plaza fronts.
    - d). A minimum of fifty percent (50%) of required seating must have seat backs.
  - ii. Design Guidelines
    - a). Adjacent buildings should provide ground level spaces fronting onto the through BLOCK plaza for commercial uses including, but not limited to, the arts & creative enterprise, eating & drinking, and retail USE categories.
    - b). Exterior walls fronting onto the through BLOCK plaza should meet the GROUND STORY FENESTRATION and BLANK WALL standards for the appropriate BUILDING TYPE to every extent practicable.
    - c). UPPER STORY balconies and terraces overlooking the through BLOCK plaza are encouraged for adjacent buildings.
- e. Pocket Plazas
  - i. DEVELOPMENT Standards
    - a). Contiguous LOTS designed as pocket plazas are considered the central plaza type if, in





combination, the total land area exceeds the maximum size standard for a single pocket plaza.

- b). Pocket Plazas must be generally rectilinear in shape (e.g. rectangular or square).
  - c). Pocket Plazas must have a minimum average width and depth of forty (40) feet and a maximum width that is not greater than three (3) times the average depth, measured perpendicularly from the ABUTTING sidewalk.
  - d). All points within a Pocket Plaza must be visible when viewed perpendicularly from the sidewalk of the ABUTTING THOROUGHFARE. Visibility of a Pocket Plaza is not affected by permitted obstructions.
  - e). Pocket Plazas must be open to the sky and unobstructed except for the following features, equipment, and appurtenances: bicycle racks; lighting; litter receptacles; PLANTERS, PLANTING BEDS, lawns, trees, and other landscape features; outdoor cafes and kiosks; public art; seating, including movable chairs, fixed individual seats, fixed benches, seat walls, PLANTER and fountain ledges, and/or seating steps; stages; temporary exhibitions; and water features.
    - i). Trees planted flush-to-grade and lawn, turf, or grass areas that do not differ in elevation from the surface of the plaza by more than six (6) inches are not considered obstructions.
    - ii). Obstructions that are non-permanent or moveable, such as moveable furniture, outdoor cafes, or temporary exhibitions are considered within gross areas designated on a SITE plan and not measured as individual pieces of furniture.
    - iii). Approved BUILDING awnings, canopies, and SIGNS are exempt.
  - f). The first fifteen (15) feet of a Pocket Plaza measured perpendicularly from any FRONT LOT LINE is considered the FRONTAGE AREA of a plaza. At least fifty percent (50%) of the FRONTAGE AREA must be free from obstructions.
  - g). Unobstructed pedestrian circulation paths must connect any ABUTTING sidewalk to all pocket plaza and BUILDING entrances.
  - h). The surface of a Pocket Plaza must be equal to the average elevation of the ABUTTING sidewalk, publicly ACCESSIBLE walkways, or other CIVIC SPACES. Minor changes in elevation not exceeding two (2) feet are permitted.
  - i). Paving must be of non-skid, durable materials that are decorative and compatible in color and pattern with other design features of the Pocket Plaza.
  - j). Each pocket plaza must provide at least two types of seating.
  - k). A minimum of one (1) linear foot of required seating for every two linear feet of frontage (FRONT LOT LINE) must be located within the FRONTAGE AREA of a plaza. A minimum of fifty percent (50%) of this seating must have seat backs and at least fifty percent (50%) of the seating with seat backs must face the sidewalk.
  - l). Seat walls and seating steps may not, in aggregate, represent more than fifteen (15) percent of the linear feet of required seating.
  - m). Steps provided for pedestrian circulation must have a height (rise) between 4 to 6 inches and minimum tread (run) of 17 inches, except that steps with a height (rise) of 5 inches may have a minimum tread (run) of 15 inches.
  - n). One bicycle rack designed for parking two bicycles is required.
- ii. Design Guidelines
    - a). A Pocket Plaza should contain areas of hardscape complemented by PLANTING BEDS or arrangements of trees with open, spreading canopies.
    - b). Plantings should contribute to the spatial definition of the space as an outdoor room.
    - c). Benches and seating ledges or walls should be designed for the convenience and comfort of visitors, located in support of gathering spaces and along pedestrian circulation paths, but should be out of the flow of pedestrian traffic. Entrances should be well designed to make visitors feel welcome and comfortable entering the space.
    - d). Water features, including fountains and waterfalls, are encouraged.

# 13. PUBLIC REALM

## Civic Space

### 6. Civic Uses

#### a. General

- i. The USE of CIVIC SPACE is permitted as specified on Table 13.1.7 Permitted Civic Uses.
- ii. CIVIC SPACES may have one or more civic USES to meet the needs of a variety of USERS or only a single USE intended for a specific USER group, such as an athletic field, community garden, dog park, or playground.
- iii. USE categories not identified on Table 13.1.7 may be permitted by the review board by Site Plan Approval.

#### b. DEVELOPMENT Review

- i. The establishment of any civic USE, CHANGE IN USE, and any expansion of an existing civic USE requires the submittal of a development review application to the BUILDING OFFICIAL.
- ii. Civic USES must comply with any USE-specific standards applicable for each USE in §13.1.7 Civic Use Definitions & Limitations.
- iii. Civic USES permitted by Special Permit require additional DEVELOPMENT review in accordance with §15.2.1 Special Permits.

#### c. Classification of Uses

- i. Civic USES are grouped into categories, and some categories are further broken into a list of individual civic USES. For example, under the Passive Space civic USE category is Botanical Garden, which is a more strictly regulated civic USE than others in this same category.
- ii. Civic USES are grouped into categories so that USES with similar functional or physical characteristics, the type and amount of activity, the conduct of visitors, and likely impact on surrounding properties are regulated similarly.
- iii. Civic USE categories are listed on Table 13.1.7 and ordered in the text of this Section using the same headings.

#### d. Civic Use Definitions & Standards

##### i. General

- a). This Section provides definitions for civic USE categories and individual USES and identifies standards applicable to either all USES within a category or specifically to an individual USE.
- b). In some cases, a civic USE may include ANCILLARY activities that are subordinate and incidental to the day-to-day operations of the PRINCIPAL USE. When identified, such ANCILLARY activities do not require separate approval, but must comply with any standards applicable to the civic USE.

##### ii. Athletic Fields

A facility providing for active recreation, athletic activity, and competitive sports.

##### a). DEVELOPMENT Standards

- i). Athletic fields must provide regulation field and COURT sizes tailored to the needs of the specific USER groups the space is intended to serve.
  - ii). The area of an athletic field is subtracted from the total area of a CIVIC SPACE to determine required trees, up to a maximum of fifty percent (50%) of the total area of a CIVIC SPACE.
  - iii). The materials and construction methods of any athletic field, including the choice of natural turf or synthetic fields, must be designed to accommodate the projected carrying capacity of the field or COURT. Particular attention must be paid to permeability of subsurface materials, soil compaction, and drainage.
- #### b). Design Guidelines
- i). Multi-purpose athletic fields that permit more cost-effective maintenance and shared amenities along with irrigation and lighting INFRASTRUCTURE are highly encouraged.
  - ii). Choices for synthetic or natural turf should take into account community desire, maintenance and appropriateness to the SITE.
  - iii). Playing surface for COURT games should be designed with appropriate surfaces such as clay, sand, and concrete, asphalt, or synthetic materials without expansion joints.
  - iv). The long axis of all recreation fields should be oriented to the north-south to every extent possible.
- #### iii. Cafe Seating

A facility equipped with tables and chairs USED for passive recreational activities including, but not limited to, sitting, eating, and game playing alone or in groups.

##### a). DEVELOPMENT Standards

- i). Cafe seating may occupy no more than fifty percent (50%) of the total area of a CIVIC SPACE.
- ii). The cafe seating area is subtracted from the total area of a CIVIC SPACE to determine required trees, up to a maximum of fifty percent (50%) of the total area of a CIVIC SPACE.
- iii). Cafe areas with food service must provide one (1) compacting combination litter/recycling receptacle for every one thousand five-hundred (1,500) square feet of area occupied by seating.



**Table 13.1.7 Permitted Civic Uses**

Use Category Specific Use	Regional Park	Community Park	Neighborhood Park	Pocket Park	Public Common	Public Square	Green	Central Plaza	Through Block Plaza	Pock(et) Plaza	Use Specific Standards
<b>Civic Uses</b>											
Athletic Fields	SP	SP	SP	N	SP	N	N	N	N	N	13.1.7.d.ii
Cafe Seating	P	P	P	P	P	P	P	P	P	P	13.1.7.d.iii
Cafe Seating for an Adjacent Use	SP	SP	SP	SP	SP	SP	SP	SP	SP	SP	13.1.7.d.iii.c
Dog Park	P	P	P	P	N	N	N	N	N	N	13.1.7.d.iv
Public Service	P	P	P	P	P	P	P	P	P	P	13.1.7.d.v
Landmark	SP	SP	SP	SP	SP	SP	SP	SP	SP	SP	13.1.7.d.vi
Passive Space (except as noted below)	P	P	P	P	P	P	P	P	P	P	13.1.7.d.vii
Botanical Garden	SP	SP	SP	SP	SP	SP	SP	SP	SP	SP	13.1.7.d.vii.c
Performance Space	P	P	P	P	P	P	P	P	P	P	13.1.7.d.viii
Playground	P	P	P	P	P	N	N	N	N	N	13.1.7.d.ix
School Yard	P	P	P	N	N	N	N	N	N	N	13.1.7.d.x
Skate Park/Rink	P	P	P	N	P	P	N	P	N	N	13.1.7.d.xi
Urban Agriculture	P	P	P	P	P	P	P	P	N	P	13.1.7.d.xii
Water Feature (except as noted below)	P	P	P	P	P	P	P	P	P	P	13.1.7.d.xiii
Pool	SP	SP	SP	N	N	N	N	N	N	N	13.1.7.d.xii.c

P - Permitted      SP - Special Permit Required      N - Not Permitted

- b). Design Guidelines
  - i). Reserved
- c). Cafe Seating for an Adjacent Use
  - i). Cafe seating may be permitted within a CIVIC SPACE for adjacent Food & Beverage Service PRINCIPAL USES by Special Permit.
  - ii). In addition to the review criteria for all Special Permits specified in §15.2.1.e. Review Criteria, the review board shall make findings considering the following in its discretion to approve or deny cafe seating within a CIVIC SPACE for an adjacent Food & Beverage Service PRINCIPAL USE:
    - a. The percentage of the CIVIC SPACE proposed to be occupied by the café seating and the viability of the remaining area to properly function as the intended type of CIVIC SPACE.
    - b. Recommendations provided by the Urban Design Commission for

the original Development Review Application submitted for the CIVIC SPACE.

- iv. Dog Park
 

A facility designed for the active recreation of dogs and their owners.

  - a). DEVELOPMENT Standards
    - i). Dog parks must be a minimum of ten thousand (10,000) square feet in area.
    - ii). The area of a dog park is subtracted from the total area of a CIVIC SPACE to determine required trees.
    - iii). Dog parks are not permitted adjacent to play grounds, recreation fields, and community gardens.
    - iv). A dog park is not permitted to be less than fifteen (15) feet in any dimension.
    - v). Dog parks must be fenced on all sides to a minimum height of 60 inches. Fence footings must be buried to a depth of one

# 13. PUBLIC REALM

## Civic Space

- (1) foot and fence panels must be buried to a depth of six (6) inches at all locations except at entrances/exits.
- vi). Dog parks must have two entrances/exits.
- vii). Entrances/exits must have a safety gate, with an outer and inner gate on either side of a minimum sixteen (16) square-foot “vestibule” area. This “vestibule” area serves as a buffer between the entrance and the rest of the park.
- viii). One (1) litter receptacle and one (1) dog valet must be provided near each entrance/exit.
- ix). A sub-base of crushed gravel or equivalent that will compact to a dense, graded permeable subsurface must be provided.
- x). GROUND COVER must be decomposed (crushed) granite or similar material that is non water-absorbing and devoid of organic material.
- xi). PLANTING BEDS must be included along the outside of the perimeter fence to help screen the dog park and reduce potential runoff.
- xii). Dog parks must include a watering area with a standard hose-bib.
- xiii). Each dog park must have a permanent SIGN, stating the hours of operation, rules, and regulations for the dog park.
- b). Design Guidelines
  - i). Separated play areas for small dogs and large dogs are recommended.
- c). DEVELOPMENT Review
  - i). The size of a Dog Park may be reduced by Special Permit.
  - ii). In its discretion to approve or deny a Special Permit authorizing a dog park under ten thousand (10,000) square feet in size, the Planning Board shall make findings considering the following in addition to the review considerations for all Special Permits specified in §15.D.1.e. Review Criteria:
    - a. Proximity to existing nearby properties in residential USE.
    - b. Proximity of the proposed dog park to larger existing dog parks that might provide more running/activity space for dogs.
    - c. The necessity to limit USE of the dog park due to the decreased size.
    - d. The design quality of the proposed dog park in relation to the decreased size.
    - e. The provision of adequate space for the recreation of dogs.
- v). Public Service
  - Essential government services provided to the community at large including municipal operations of the City of Somerville, such as departmental offices, social service facilities, and public works facilities; public safety services, such as police and firefighting headquarters and substations; and OPEN SPACES reserved for social and recreational activities or natural resource protection.
    - a). DEVELOPMENT Standards
      - i). Reserved
    - b). Design Guidelines
      - i). Reserved
- vi). Landmark
  - A feature of a CIVIC SPACE designed to commemorate an important event or important person in the HISTORY of the City of Somerville.
    - a). DEVELOPMENT Standards
      - i). Historic landmarks must be reviewed by the Historic Commission.
      - ii). Landmarks recognizing veterans must be reviewed by the Veteran’s Commission.
    - b). Design Guidelines
      - i). Landmarks can take many forms including stone or metal memorials and monuments, statues, plaques, SIGNAGE, or landscape designs.
      - ii). Landmark design, size, and placement should be appropriate and for the SITE.
      - iii). Maintenance of landmarks, including any associated lighting, should be considered in the design.
      - iv). Landmarks should be considered as special features that bring people together for a moment or longer and enliven the experience of residents and visitors in exploring the City of Somerville.
- vii). Passive Space
  - A feature of a CIVIC SPACE designed to accommodate passive recreational activities including, but not limited to, exercising, laying, people-watching, picnicking, reading, relaxing, standing, sitting, and walking alone or in groups.
    - a). DEVELOPMENT Standards
      - i). Reserved
    - b). Design Guidelines
      - i). Reserved
    - c). Botanical Garden
      - A feature of a CIVIC SPACE designed specifically for the cultivation of specimen plants for scientific research, conservation, education, and public display.
        - i). DEVELOPMENT Standards

- a. Botanical gardens must be curated by an institution with experience managing collections of plants, or associated with a school, public committee, or private club.
  - ii). Design Guidelines
    - a. Reserved
- viii. Performance Space

A feature of a CIVIC SPACE designed as an outdoor venue for live performance of cultural entertainment or artistic expression such as singing, dancing, comedy, literary readings, performance art, musical theater, live plays, and concerts.

  - a). DEVELOPMENT Standards
    - i). Reserved
  - b). Design Guidelines
    - i). Reserved
- ix. Playground

A facility primarily designed as a play area for children.

  - a). DEVELOPMENT Standards
    - i). Playgrounds must be a minimum of two thousand five hundred (2,500) and a maximum of twenty five thousand (25,000) square feet in area.
    - ii). The area of a playground is subtracted from the total area of a CIVIC SPACE TO determine required trees.
    - iii). Design and construction of a playground must comply with the US Consumer Product Safety Commission's Public Playground Safety Handbook.
    - iv). Only commercial grade play equipment certified by the manufacturer is permitted.
    - v). Playground must include seating intended for parents.
    - vi). Playground surfacing must be composed of a shock-absorbing surface with a maximum 2% slope except where intentionally mounded for play activities. The material must meet all federal, state and local regulations.
  - b). Design Guidelines
    - i). Playgrounds should be designed to engage children and adolescents in developing their physical and social skills in a stimulating and safe environment.
    - ii). Playgrounds should include equipment for two at least age groups: play equipment intended for children ages one (1) to five (5), play equipment intended for children ages six (6) to ten (10), and play equipment for adolescents up to eighteen (18) years in age.
- iii). Playgrounds should be designed to meet the widest range in needs of children of different ages and abilities to every extent possible.
- iv). Parks that have playground equipment, sports fields, and spray pads should be ACCESSIBLE to all children up to eighteen (18) years in age.
- v). Parks that have playground equipment, sports fields, and spray pads should be ACCESSIBLE to all children up to eighteen (18) years in age.
- vi). Natural play areas constructed of boulders, logs and land forms and playground equipment made from one hundred percent (100%) recycled plastic or steel is recommended.
- vii). Steel play STRUCTURES should be shaded by trees or other shade STRUCTURES to decrease their surface temperature in the summer months.
- x. School Yard

A facility designed to accommodate play and learning by students of adjacent schools and by the community during after-school hours or breaks.

  - a). DEVELOPMENT Standards
    - i). Reserved
  - b). Design Guidelines
    - i). Reserved
- xi. Skate Rink/Park

A facility providing a level surface intended for USE by ice or other type of skating or a collection of ramps and other obstacles intended for USE by skateboarders or bicyclists.

  - a). DEVELOPMENT Standards
    - i). Reserved
  - b). Design Guidelines
    - i). Reserved
- xii. Urban Agriculture

A feature of a CIVIC SPACE designed as individual garden PLOTS available to residents for agricultural purposes, including storage facilities for necessary equipment.

  - a). DEVELOPMENT Standards
    - i). Community gardens must be located in areas that are agriculturally suitable, including soil conditions, topography, and solar ACCESS.
    - ii). Land area of a community garden must be level enough to support the intended USE and meet all Americans with Disabilities Act requirements without the USE of RETAINING WALLS that exceed three (3) feet in

# 13. PUBLIC REALM

## Civic Space

height.

iii). A walkway must be provided adjacent to each individual PLOT. All walkways must have a minimum width of four (4) feet and all walkways, paths, and landings must meet ADA requirements.

iv). A permanent, visually transparent fence must be provided at the perimeter of the community garden. Fencing must provide at least one (1) ACCESS gate and at least eight percent (80%) free from vines or other obstructions that will impede visual ACCESS.

v). Refuse areas must be provided and screened to enclose all refuse generated from the garden PLOTS. Composters and trash barrels must be rodent proof. Storage areas for tools, fertilizers, equipment, and other material must be enclosed and located in relative proximity to the rear and center of the SITE.

vi). A water meter and hose bibs must be provided on SITE to provide ACCESS to all PLOTS within the garden with the USE of a twenty-five (25) foot hose. Hose bibs must be secured to a post and include a hose hanger.

vii). SIGNAGE constructed of commercial grade outdoor materials must be posted at the entrance to the community garden providing the hours of operation, contact name and phone number, community garden rules, and the statement "on-SITE sale of produce is not permitted."

viii). Farm-stands and the on-SITE sale of produce are prohibited.

ix). The maximum permitted height for ACCESSORY STRUCTURES, such as trellises, ARBORS, or other plant supports, is six (6) feet.

x). The maximum height of any STRUCTURE intended for storage is eight (8) feet.

### b). Design Guidelines

i). At least twelve (12) individual garden PLOTS should be provided.

ii). A minimum of one ACCESSIBLE PLOT should be provided for every twelve (12) PLOTS.

iii). The minimum size of individual garden PLOTS should be twenty-five (25) square feet.

### xiii. Water Feature

A feature of a CIVIC SPACE involving water including, but not limited to, fountains, pools, ponds, cascades, waterfalls, and streams.

### a). DEVELOPMENT Standards

i). Reserved

### b). Design Guidelines

i). Reserved

### c). Pool

A facility for swimming.

#### i). DEVELOPMENT Standards

a. Reserved

#### ii). Design Guidelines

a. Reserved

## 13.2 THOROUGHFARES

### 1. Development Review

- a. The DEVELOPMENT of any new THOROUGHFARE requires Site Plan Approval followed by a Thoroughfare Permit, in accordance with Chapter 15: Administration.
- b. All DEVELOPMENT, excluding NORMAL MAINTENANCE, requires the submittal of a development review application to the BUILDING OFFICIAL and the issuance of a Certificate of Zoning Compliance prior to the issuance of a Thoroughfare Permit.

### 2. Standards for all Thoroughfare Type

- a. THOROUGHFARES, excluding ALLEYS, must include travel lanes and sidewalks.
- b. THOROUGHFARES must be designed in accordance with the current edition of the National Association of City Transportation Officials (NACTO) STREET design guidelines:
  - i. The Urban STREET Design Guide
  - ii. The Transit STREET Design Guide
  - iii. Urban Bikeway Design Guide
  - iv. Urban STREET Stormwater Guide
- c. THOROUGHFARES must be engineered and constructed as required by the City Engineer, in consultation with the Director of Public Space & Urban Forestry.
- d. All water and sewer utilities, storm water management infrastructure, public lighting, and public furniture must be designed and constructed in accordance with all standards established by relevant City Departments.

### 3. Standards for Specific Thoroughfare Types

- a. Commercial STREET
  - i. The commercial STREET THOROUGHFARE type is referred to as the Downtown 2-Way STREET by NACTO.
  - ii. The total right-of-way width must be a minimum of seventy-four (74) feet.
    - a). If protected bike lanes are provided, the minimum right-of-way width is increased to eighty (80) feet.
  - iii. Commercial STREETS must include bicycle lanes in each direction.
  - iv. Total right of way width may be reduced by seven (7) feet for each parking lane that is not provided.
- b. Local STREET
  - i. The local STREET THOROUGHFARE type is referred to as a Neighborhood STREET by NACTO.
  - ii. The total local STREET right-of-way width must be a minimum of sixty (60) feet.
  - iii. Total right of way width may be reduced by seven (7) feet for each parking lane that is not provided.
  - iv. The maximum length of a local STREET must be no more than three (3) BLOCKS lengths.
- c. Commercial Shared STREET

- i. The commercial shared STREET THOROUGHFARE type is referred to as a Commercial Shared STREET by NACTO.
- ii. The total local STREET right-of-way width must be a minimum of fifty-two (52) feet.
- iii. Total right of way width may be reduced by seven (7) feet for each parking lane that is not provided.
- d. ALLEYS
  - i. The ALLEY THOROUGHFARE type is referred to as a Commercial ALLEY by NACTO.
  - ii. New ALLEYS must include travel lanes in each direction, and may include sidewalks.
  - iii. The total ALLEY right-of-way width must be a minimum of twenty (20) feet.
  - iv. On STREET parking is not permitted.

### 4. Sidewalks

- a. General
  - i. All new and reconstructed sidewalks must be ACCESSIBLE to and usable by persons with disabilities in accordance with the Americans with Disabilities Act and the Rules and Regulations of the Massachusetts ACCESS Board (521 CMR), as amended.
  - ii. Sidewalks for new THOROUGHFARES must include a walkway and furnishing zone and may include an edge and frontage zone as illustrated in Figure 13.2.4 (a) Sidewalks.
    - a). Walkways must be a minimum of six (6) feet in width.
    - b). Furnishing zones must be a minimum of six (6) feet in width.
    - c). Edge zones (ie. "curbwalks") must be a minimum of two (2) feet in width.
    - d). Frontage zones may be a maximum of four and a half (4.5) feet in width.
  - iii. Furnishing zones may be alternated with an on-STREET parking area on commercial shared STREETS.
  - iv. Protected bike lanes must be separated from the walkway of the sidewalk by a furnishing zone.
- b. Existing THOROUGHFARES
  - i. Installation of a STREET TREE into a sidewalk that existed prior to the adoption date of this Ordinance must be planted as required by the Director of Public Space & Urban Forestry.
- c. New THOROUGHFARES
  - i. Sidewalks must include LARGE TREES planted within the furnishing zone, except for ALLEY sidewalks.
  - ii. Trees must be planted in a regularly-spaced ALLEE pattern between thirty-five (35) and forty-five (45) feet on center, as required by the Director of Public Space & Urban Forestry depending on species or



# 13. PUBLIC REALM

## Thoroughfares

CULTIVAR of tree.

- a). Along retail frontages, STREET TREES may be planted in an irregularly-spaced ALLEE pattern to avoid visually obscuring storefront windows and SIGNAGE.
- b). The review boards may grant a WAIVER from the STREET TREE requirements of this section only for sidewalks in front of TERMINATED VISTAS and ABUTTING CIVIC SPACES.
- iii. At least one thousand (1,000) gross cubic feet of uncompacted SOIL VOLUME must be provided for each tree within a maximum twenty-seven (27) foot radius of the tree trunk.
  - a). Where required SOIL VOLUMES for nearby trees overlap, up to twenty-five percent (25%) of the required SOIL VOLUME per tree may be shared between trees.
  - b). SOIL VOLUME under paved surfaces must be provided through SUSPENDED PAVEMENTS or STRUCTURAL CELLS. A SAND-BASED STRUCTURAL SOIL SYSTEM may be used with approval of the Director of Public Space & Urban Forestry.
- iv. When planted, trees must be a minimum height of ten (10) feet or two (2) inches in CALIPER.
- v. TREE PITS must have a minimum thirty six (36) sq. ft. (such as 6'x6') open soil area not covered by paving, centered at the tree trunk.
- vi. To reduce soil compaction, shield a tree's trunk from physical damage, and prevent pet waste from

Figure 13.2.4 (a) Sidewalks

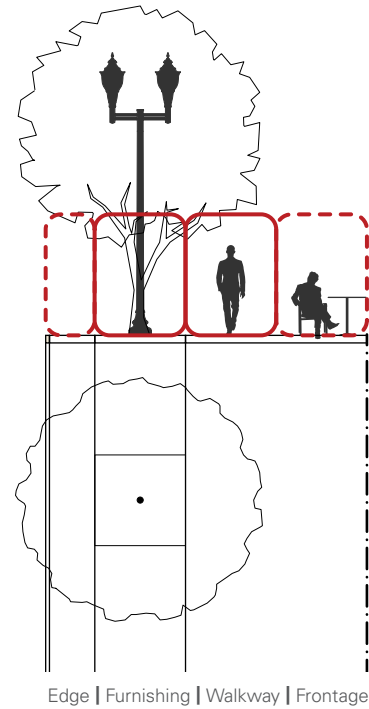

entering the soil area, a TREE GUARD at least eighteen (18) inches tall must be installed around the outer perimeter of the TREE PIT.

a). For sidewalks without an edge zone (i.e.

Figure 13.2.4 (b) Structural Cell Example





**Figure 13.2.3 Example Tree Pits & Guards**



'Curbwalk'), TREE GUARDS must be three-sided and positioned at least one foot short of the outer edge of the curb, with the curbside remaining open (not fenced).

- b). For sidewalks with an edge zone, TREE GUARDS must provide protection on all four sides of the TREE PIT.
- c). TREE GUARDS must allow for water to flow from the sidewalk into the TREE PIT.
- vii. Coarse grade GROUNDCOVER MULCH must be applied to the soil area at a depth of at least two (2) inches and distributed to create a smooth, level cover over the exposed soil at the time of planting.
  - a). A gap of approximately eight (8) inches must be left between the mulch and the trunk of the tree to avoid mounding above the trunk flare.
- viii. Trench drains located between the curb and furnishing zone or between the furnishing zone and walkway are recommended to maximize water infiltration into the soil provided for STREET TREES.

#### **5. Mid-Block Passages**

- a. Mid-BLOCK passages must connect the sidewalk of one THOROUGHFARE to the sidewalk of another THOROUGHFARE on opposite sides of a BLOCK.
- b. Mid-BLOCK passages may be designed as an open-air passage between buildings, a covered atrium providing continuous protection from the elements, or as an up to two-STORY passage through a BUILDING.
- c. Open air mid-BLOCK passages must be at least twenty (20) feet in width, with a minimum ten (10) foot wide paved walkway designed as a continuation of the sidewalks they connect, including materials and sidewalk furnishings.
- d. A covered mid-BLOCK passage must be at least twenty (20) feet in width.
- e. All mid-BLOCK passages must be lighted using footlights, bollard lights, BUILDING lights, or STREET lights to provide for safety and visibility at night.

# 13. PUBLIC REALM

# 14 NONCONFORMANCE

<b>14.1 NONCONFORMITIES .....</b>	<b>525</b>
General	525
Determination of Status	525
Basic Rights	525
Nonconforming Lots	525
Nonconforming Structures	525
Nonconforming Uses	526
Nonconforming Site Characteristics	526
Nonconforming Signs	527
Casualty	527
Abandonment	527



## 14.1 NONCONFORMITIES

### 1. General

- a. The adoption and occasional amendment of the Somerville Zoning Ordinance and Official Zoning Atlas, including the adoption of the City's first zoning ordinance, can cause previously lawfully conforming LOTS, STRUCTURES, USES, SITE characteristics, and SIGNS to become nonconforming to new regulations.
- b. This section explains the impact of this nonconforming status ON DEVELOPMENT.

### 2. Determination of Status

- a. A LOT, STRUCTURE, USE, SITE characteristic, or SIGN that existed prior to the establishment of zoning in Somerville or that complied with the Somerville Zoning Ordinance when platted, built, or established and remains in compliance with subsequent amendments to the Somerville Zoning Ordinance is lawfully conforming.
- b. A LOT, STRUCTURE, USE, SITE characteristic, or SIGN that existed prior to the establishment of zoning in Somerville or that complied with the Somerville Zoning Ordinance when platted, built, or established but has become non-compliant to a subsequent amendment of the Somerville Zoning Ordinance is an existing NONCONFORMITY.
- c. The burden of proving that a LOT, STRUCTURE, USE, SITE characteristic, or SIGN is an existing NONCONFORMITY rests entirely with the PROPERTY OWNER.
- d. APPLICANTS applying for DEVELOPMENT review required by this section may be required to submit evidence of a prior permit or other documentation showing that the LOT, STRUCTURE, USE, SITE characteristic, or SIGN was legally platted, built, or established prior to the effective date of this Ordinance or any amendment to this Ordinance.
- e. The BUILDING OFFICIAL shall determine whether reliable evidence of nonconforming status has been provided by the PROPERTY OWNER.

### 3. Basic Rights

- a. Existing nonconforming LOTS, STRUCTURES, or USES may continue in the same form and USE so long as the NONCONFORMITY remains otherwise compliant with this Ordinance.
- b. Status as a existing NONCONFORMITY runs with the LOT, STRUCTURE, USE, SITE characteristic, or SIGN and is not affected by changes in tenancy, ownership, or management.

### 4. Nonconforming Lots

- a. Description
  - i. A nonconforming LOT is a LOT that was lawfully platted, but that no longer complies with the

provisions of this Ordinance due to its adoption or amendment.

- b. Unbuildable Lots
  - i. DEVELOPMENT is prohibited for any vacant LOT that is nonconforming to the LOT frontage requirement of §10.1.6.a (frontage on a THOROUGHFARE OR CIVIC SPACE) or to the LOT width or LOT DEPTH requirements for any BUILDING TYPE permitted for the zoning district where the LOT is located.
- c. Existing Structures
  - i. MODIFICATION of any existing PRINCIPAL BUILDING TYPE into a different BUILDING TYPE is prohibited for any LOT that is nonconforming to the LOT frontage requirement of §10.1.6.a.
- d. Land Platting
  - i. A LOT SPLIT, LOT MERGER, OR LOT LINE ADJUSTMENT, OR SUBDIVISION that would result in a new nonconforming LOT is prohibited.
  - ii. LOT SPLITS, LOT MERGERS, OR LOT LINE ADJUSTMENTS to any LOT that does not have frontage on a THOROUGHFARE or a CIVIC SPACE is permitted only when the split, merger, or adjustment dissolves the LOT or increases the conformity of ABUTTING LOTS.

### 5. Nonconforming Structures

- a. Description
  - i. A nonconforming structure is any PRINCIPAL BUILDING TYPE, building component, ACCESSORY BUILDING TYPE, OR ACCESSORY structure that was lawfully built, but that no longer complies with the provisions of this Ordinance due to its adoption or amendment.
- b. Ordinary Repair and Maintenance
  - i. NORMAL MAINTENANCE of a nonconforming structure is permitted.
- c. MODIFICATIONS
  - i. Any MODIFICATION to an existing PRINCIPAL BUILDING TYPE, building component, OR ACCESSORY BUILDING TYPE that is not one of the BUILDING TYPES permitted in a zoning district is prohibited, except as follows:
    - a). Any conforming building component permitted within the same zoning district may be added to a nonconforming principal OR ACCESSORY BUILDING TYPE by Special Permit.
    - b). MODIFICATIONS to a nonconforming principal OR ACCESSORY BUILDING TYPE USED for religious or educational activities per M.G.L. Chapter 40A, Section 3 are permitted in accordance with the largest permitted BUILDING TYPE.
  - ii. Any MODIFICATION to a permitted PRINCIPAL BUILDING TYPE, BUILDING component, OR ACCESSORY BUILDING TYPE that is nonconforming to any standard for that specific PRINCIPAL BUILDING TYPE, BUILDING component,

# 14. NONCONFORMANCE

## Nonconformities

OR ACCESSORY BUILDING TYPE is permitted, subject to the following:

- a). The creation of any new NONCONFORMITY is prohibited.
- b). Any increase in an existing NONCONFORMITY is prohibited.
- d. ACCESSORY STRUCTURES
  - i. Any MODIFICATION that increases an existing NONCONFORMITY OR creates a new NONCONFORMITY is prohibited.
  - ii. Any MODIFICATION that results in greater conformance to this Ordinance is permitted.
- e. Special Permits
  - i. In addition to the review criteria for all Special Permits specified in §15.2.1.e. Review Criteria, the review board shall make findings considering the following in its discretion to approve or deny a special permit authorizing the MODIFICATION of a nonconforming STRUCTURE:
    - a). The extent and nature of the proposed alteration;
    - b). The ability of conforming alterations to meet the demonstrated need of the APPLICANT;
    - c). Consistency of the proposed alterations with the evolution of neighboring STRUCTURES.
    - d). Establishment of permeable LOT surface, to the maximum extent possible.
    - e). Conformance to design guidelines applicable to the district where the property is located.
  - ii. The review boards may not grant a special permit authorizing any MODIFICATION to an existing nonconforming structure that increases the degree of an existing NONCONFORMITY of the structure without finding that the alteration is not substantially more detrimental to the neighborhood.

### 6. Nonconforming Uses

- a. Description
  - i. A nonconforming USE is a USE that was lawfully established but that no longer complies with applicable standards because of the adoption or amendment of the Somerville Zoning Ordinance.
- b. Change of Use
  - i. A nonconforming USE may change to a conforming USE as indicated on Table 9.1 (see Article 9: Use Provisions).
  - ii. A nonconforming USE may change to another nonconforming USE that is from the same Use Category as the existing nonconforming USE by Special Permit.
  - iii. A nonconforming USE may not change to a different nonconforming USE that is from a different Use Category than the existing nonconforming USE

(eg. an existing BANKING OR FINANCIAL SERVICES USE changing into a Restaurant, Bakery, or Cafe USE in a district where neither is permitted).

- c. Alterations
  - i. The alteration of a nonconforming USE within a STRUCTURE may be permitted by Special Permit.
  - ii. A nonconforming USE is considered to be altered in, but not limited to, the following circumstances:
    - a). any increase in GROSS FLOOR AREA;
    - b). any increase in the number of DWELLING UNITS;
    - c). a change from seasonal to full-time operation; and,
    - d). any substantial increase in the number of automobile trips generated by the USE.
    - e). any change in hours of operation beyond the hours of 7:00am to 9:00pm
- d. Special Permits
  - i. In addition to the review criteria for all Special Permits specified in §15.2.1.e. Review Criteria, the review board shall make findings considering the following in its discretion to approve or deny a special permit authorizing the change of a nonconforming USE to a different nonconforming USE within the same Use Category as the existing nonconforming USE:
    - a). The impact of the CHANGE IN USE to the neighborhood when compared to the existing nonconforming USE.
  - ii. In addition to the review criteria for all Special Permits specified in §15.2.1.e. Review Criteria, the review board shall make findings considering the following in its discretion to approve or deny a special permit authorizing alterations to a nonconforming USE within a STRUCTURE:
    - a). The extent and nature of the proposed alteration;
    - b). The ability of conforming alterations to meet the demonstrated need of the APPLICANT;
    - c). Consistency of the proposed alterations with the evolution of neighboring STRUCTURES.
    - d). the impact of the alteration to the neighborhood when compared to the existing nonconforming USE.

### 7. Nonconforming Site Characteristics

- a. Immunity
  - i. Nonconforming SITE characteristics, including parking and permeable area requirements, do not CAUSE STRUCTURES OR USES that are otherwise conforming to the provisions of this Ordinance to become nonconforming.
- b. Alterations
  - i. Nonconforming PARKING LOTS cannot be expanded in violation or further violation of maximum parking



# 14. NONCONFORMANCE

## Nonconformities

- requirements.
- ii. Nonconforming landscape and permeable area cannot be further reduced.
- c. Improvement
  - i. Review boards may require nonconforming SITE characteristics to be brought into conformance with the provisions of this Ordinance as a condition applied to a discretionary or administrative permit.

### 8. Nonconforming Signs

- a. A nonconforming SIGN may alter content, but may not:
  - i. Be replaced with a SIGN that is larger in any dimension than the existing SIGN;
  - ii. Alter lighting technology, except to bring the technology into compliance with the ordinance.
- b. No establishment with a nonconforming SIGN may add additional SIGNS without bringing nonconforming SIGNS into compliance.

### 9. Casualty

- a. Lawfully existing nonconforming real property destroyed by fire, explosion, weather, flooding, or act of public enemy may be reconstructed or restored by-right subject to the following:
  - i. MODIFICATION TO NONCONFORMITIES prior to destruction are not permitted;
  - ii. reconstruction or restoration must be started within two (2) years of the date of destruction and must be continued in a timely fashion until completed.
- b. The BUILDING OFFICIAL shall not issue a Building Permit or Certificate of Occupancy unless the No BUILDING Permit shall be issued until a zoning permit has been granted by the BUILDING OFFICIAL.

### 10. Abandonment

- a. Lawfully existing nonconforming real property is considered abandoned when one or more of the following conditions exist:
  - i. the USE is changed to a USE permitted in the district where the property is located;
  - ii. the USE is changed to a USE protected under MGL 40A, Section 3;
  - iii. the USE is discontinued, whether temporarily or permanently, with or without intent to abandon, for a period of two (2) years or more;
  - iv. equipment or furnishings necessary for the operation of the nonconforming USE have been removed and not replaced for a period of one (1) year or more;
  - v. utilities, such as water, gas, or electricity to the property have been disconnected for over one (1) year; and/or
  - vi. reconstruction or restoration does not start within a

- period of two (2) years from the date of destruction of lawfully existing nonconforming real property.
- b. Nonconforming real property that has been abandoned may not be reestablished or resumed until brought into conformance with this Ordinance.

# 14. NONCONFORMANCE

Nonconformities

# 15 ADMINISTRATION

<b>15.1 REVIEW PROCEDURES .....</b>	<b>531</b>
General	531
Pre-Submittal Meeting	531
Neighborhood Meeting	531
Design Review	532
Development Review Application	532
Application Review & Staff Report	533
Public Notice	534
Public Hearing	534
Decision	535
Appeal	535
Certification of Decision	535
Certificate of Zoning Compliance	535
<b>15.2 DISCRETIONARY PERMITS .....</b>	<b>536</b>
Special Permit	536
Master Plan Special Permit	537
Hardship Variance	538
Plan Revision	539
<b>15.3 ADMINISTRATIVE PERMITS .....</b>	<b>540</b>
Subdivision Plan Approval	540
Site Plan Approval	540
Thoroughfare Permit	541
Civic Space Permit	542
Building Permit	542
<b>15.4 CERTIFICATES .....</b>	<b>544</b>
Certificate of Zoning Compliance	544
Certificate of Occupancy	544
Written Interpretation	545
<b>15.5 APPEALS.....</b>	<b>546</b>
Building Code Appeal	546
Administrative Appeal	546
Judicial Appeal	546
<b>15.6 LEGISLATIVE PROCEDURES.....</b>	<b>547</b>
Land Conveyance	547
Zoning Text Amendment	547
Zoning Map Amendment	548
<b>15.7 REVIEW BOARDS &amp; OFFICIALS.....</b>	<b>549</b>
Building Official	549
Zoning Board of Appeals	549
Planning Board	549
Urban Design Commission	550



## **15.1 REVIEW PROCEDURES**

### **1. General**

- a. All DEVELOPMENT, excluding NORMAL MAINTENANCE, requires the submittal of a development review application to the BUILDING OFFICIAL and the issuance of a Certificate of Zoning Compliance prior to the issuance of a Building Permit or Certificate of Occupancy.
- b. Proposed DEVELOPMENT may or may not necessitate the need for a Discretionary or administrative permit based on the nature of the proposal.
- c. This Section describes the various common procedures required for development review applications. See Section 15.2 Discretionary Permits and Section 15.3 Administrative Permits for the specific procedural steps required for each type of permit.

### **2. Pre-Submittal Meeting**

- a. Purpose
  - i. To inform APPLICANTS of relevant development review application criteria, standards, and procedures.
  - ii. To examine previous development review applications and permits for the subject property.
  - iii. To identify any potential concerns at the earliest opportunity in the DEVELOPMENT review process.
- b. Procedure
  - i. When a pre-submittal meeting is required by this Ordinance, development review applications are not considered complete until the pre-submittal meeting has been held with Planning Staff.
  - ii. Unless otherwise specified, a required pre-submittal meeting must occur at least fourteen (14) days prior to any required neighborhood meeting, at least fourteen (14) days prior to any required design review, and at least three (3) days prior to submittal of a development review application.
  - iii. APPLICANTS or their representatives are required to attend a pre-submittal meeting.
  - iv. APPLICANTS are required to bring all information and materials required by the BUILDING OFFICIAL and Director of Planning & Zoning to a pre-submittal meeting.

### **3. Neighborhood Meeting**

- a. Purpose
  - i. To provide the public with an opportunity to review a conceptual design proposal and identify and discuss issues and potential impacts with the APPLICANT prior to the DEVELOPMENT of more detailed schematic design proposals.
  - ii. To provide the public with an opportunity to review a chosen schematic design plan and identify and discuss issues and potential impacts with the

APPLICANT prior to the submittal of a development review application.

- iii. Neighborhood meetings are required during the schematic design process to promote the submittal of a development review application that is more responsive to community concerns, expedite the review process, and to lessen the cost of DEVELOPMENT review by reducing continuances and appeals.
- b. Procedure
  - i. When a neighborhood meeting is required by this Ordinance, development review applications are not considered complete until the neighborhood meeting has been held.
  - ii. Development review applications must be submitted within one hundred and twenty (120) days of the neighborhood meeting. If an application is not submitted in this time frame, the APPLICANT is required to hold a new neighborhood meeting.
  - iii. Unless otherwise specified, a neighborhood meeting must occur at least fourteen (14) days prior to any required design review and at least fourteen (14) days prior to formal submittal of a development review application.
  - iv. Neighborhood meetings must be open to the public.
  - v. Neighborhood meetings should be held at a location in close proximity to the subject property on a weekday evening after 6:00 p.m. or on weekends at any reasonable time.
  - vi. Neighborhood meetings may not occur on a local, state, or national holiday or election day.
  - vii. APPLICANTS or their representatives, along with the designers, are required to attend a neighborhood meeting.
  - viii. The APPLICANT is responsible for coordinating a neighborhood meeting in conjunction with the Ward representative from the City Council and the Staff of the Mayor's Office of Strategic Planning and Community DEVELOPMENT.
  - ix. The format and agenda of a neighborhood meeting is at the discretion of the APPLICANT, in consultation with the Ward representative from the, City Council subject to the following:
    - a). Only one (1) DEVELOPMENT proposal may be presented to the public at a neighborhood meeting.
    - b). Attendees must be able to hear and discuss each others feedback at the neighborhood meeting and opportunity must be provided for substantive engagement between attendees and the APPLICANT, including designers, regarding the proposed DEVELOPMENT.
    - c). APPLICANTS are required to bring all information

# 15. ADMINISTRATION

## Review Procedures

and materials required by the BUILDING OFFICIAL to a neighborhood meeting.

- x. Multiple neighborhood meetings may be held on the same day, one after another, at the discretion of the Ward representative from the City Council.
- xi. The Director of Planning & Zoning shall keep a public record of the neighborhood meeting that includes, but may not be limited to, the following:
  - a). A list of those persons and organizations contacted about the meeting, and the manner and date of contact.
  - b). The date, time, and location of the meeting;
  - c). A roster or SIGNATURE sheet of attendees at the meeting.
  - d). Copies of all materials provided by the APPLICANT at the meeting.
- xii. The Director of Planning & Zoning shall record minutes of the neighborhood meeting and provide a summary of the comments, questions, and concerns discussed at the meeting to the review boards.
- xiii. The BUILDING OFFICIAL and review boards shall require APPLICANTS to submit a detailed response to concerns raised at the neighborhood meeting and a description of any changes to the proposed DEVELOPMENT made as a result of the feedback.

### 4. Design Review

- a. Purpose
  - i. To inform the selection of a preferred schematic design from a number of options.
  - ii. To provide an APPLICANT with advice or recommendations from peers in the professional design community.
  - iii. To ensure that DEVELOPMENT protects and enhances the PUBLIC REALM and human scale of the City.
- b. Authority
  - i. Unless otherwise specified, the Urban Design Commission (UDC) is the review board for Design Review.
- c. Procedure
  - i. When design review is required by this Ordinance, development review applications are not considered complete until review by the Urban Design Commission (UDC) has been completed.
  - ii. Unless otherwise specified, design review must occur at least fourteen (14) days prior to formal submittal of a development review application.
  - iii. The Director of Planning & Zoning shall post any plan drawings, presentations, or other materials submitted to the UDC on the City website.
  - iv. Staff of the Planning & Zoning Division shall serve as staff to the UDC, as may be necessary to perform its duties.

- v. The UDC shall issue a written recommendation to the Planning Board and the APPLICANT within forty-five (45) days of the design review meeting. Subsequent DEVELOPMENT review steps are prohibited until the UDC has issued its recommendation.
- vi. The UDC shall keep a public record of the design review meeting that includes, but may not be limited to, the following:
  - a). A list of those persons and organizations contacted about the meeting, and the manner and date of contact.
  - b). The date, time, and location of the meeting;
  - c). A roster or SIGNATURE sheet of attendees at the meeting.
  - d). Copies of all materials provided by the APPLICANT at the meeting.
- vii. The UDC shall record minutes of the design review meeting and provide a summary of the comments, questions, and concerns discussed at the meeting to the review boards.
- viii. The BUILDING OFFICIAL and review boards shall require APPLICANTS to submit a detailed response to concerns raised at the design review meeting and a description of any changes to the proposed DEVELOPMENT made as a result of the feedback.

### d. Review Criteria

- i. The Urban Design Commission's written recommendation to the review board must include, but may not be limited to, the following:
  - a). Identification the preferred scematic design supported by the UDC.
  - b). Identification of each design guideline that has been achieved to the satisfaction of the UDC, as voted by a majority of members present.
  - c). Any MODIFICATIONS necessary to remedy outstanding design issues for guidelines that have not been achieved to the satisfaction of the UDC, as voted by a majority of members present.
- ii. In addition to addressing the design guidelines of this Ordinance, the UDC shall provide recommendations for any design guidelines adopted by the review boards.

### 5. Development Review Application

- a. Purpose
  - i. To provide the BUILDING OFFICIAL with all of the information necessary to determine if a DEVELOPMENT proposal is permitted or necessitates the need for additional DEVELOPMENT review in accordance with this Ordinance.
- b. Submittal
  - i. Development review applications must include



all necessary information and submittal materials required by the BUILDING OFFICIAL and Review Boards. The BUILDING OFFICIAL shall make all application submittal requirements available to the public on the City website.

- a). APPLICANTS must demonstrate ownership or SITE CONTROL of a DEVELOPMENT SITE through one or more of the following:
  - i). Fee ownership or consent of the fee owner of a PARCEL;
  - ii). Leasehold interest;
  - iii). An EASEMENT agreement;
  - iv). An option to purchase or lease; or
  - v). A Land Disposition Agreement with the Somerville ReDEVELOPMENT Authority pursuant to a Revitalization Plan and the provisions of 760 CMR 12.05.
- c. Completeness
  - i. A development review application is not considered complete until all necessary information has been supplied by the APPLICANT and all fees have been paid, including fees for costs incurred by the City for public notice.
  - ii. Upon written request by an APPLICANT, the review board may, in its discretion, waive any of the information required when applying for DEVELOPMENT review.
  - iii. Completed applications will be scheduled for a public hearing, publicly noticed, or administratively evaluated as indicated for each type of discretionary or administrative permit.
  - iv. Incomplete applications will not be reviewed, will not be publicly noticed, will not be scheduled for a public hearing.
  - v. If an application reaches a public hearing and the review board deems the submittal incomplete, the board shall do one (1) of the following:
    - a). deny the application;
    - b). allow the APPLICANT to withdraw the application without prejudice according to §15.1.5.e. Withdrawal; or
    - c). allow the APPLICANT waive the procedural time requirements according to §15.1.8.d Continuance.
- d. Withdrawal
  - i. An application may be withdrawn without prejudice at any time prior to the issuance of the public notice advertising the DEVELOPMENT review public hearing where the application will be reviewed.
  - ii. Once the public notice advertising a DEVELOPMENT review public hearing has been issued, a request to withdraw an application can be granted only by a four-fifths majority of the review board.
  - iii. Upon request to withdraw without prejudice,

the review board has the option to do one of the following:

- a). approve a request to withdraw without prejudice; or
  - b). deny the request and proceed to evaluate the application based on the merits of the information submitted.
- iv. Applications withdrawn prior to public notice are not eligible for a refund of fees.
  - e. Repetitive Applications
    - i. A denied development review application will not be reconsidered for a minimum of two (2) years from the date final action was taken by the review board unless the review board determines, in accordance with M.G.L. Chapter 40A Section 16, that specific and material changes in the conditions upon which the prior denial was based, including, but not limited to, substantial new evidence or a significant mistake of law or of fact, justifies reconsideration of the application.
    - ii. If the development review application is resubmitted earlier than two (2) years from the date of final action, the development review application must include a detailed statement of the evidence justifying its reconsideration.
    - iii. The review boards shall not regard the re-submittal of development review applications withdrawn without prejudice as a repetitive application.

### 6. Application Review & Staff Report

- a. Upon receipt of a complete development review application, the BUILDING OFFICIAL shall review the development review application and, if necessary, refer the application to appropriate City Departments for feedback.
- b. For any proposed DEVELOPMENT that requires a discretionary or administrative permit, the BUILDING OFFICIAL shall forward the application to the Director of Planning & Zoning to administer the required review process with the review board(s).
- c. The Director of Planning & Zoning shall post on the City website and transmit to the review board(s) a staff report that includes, but may not be limited to, the following:
  - i. A summary overview of the proposed development;
  - ii. identification of all required discretionary and administrative permits; and
  - iii. a zoning compliance review.
- d. If a neighborhood meeting or design review meeting was required for the proposed DEVELOPMENT, the staff report must include also an account of the meeting that includes, but may not be limited to, the following:
  - a). the date, time, and location of the meeting;

# 15. ADMINISTRATION

## Review Procedures

- b). a roster of members of the Urban Design Commission in attendance at the meeting;
- c). a summary of issues discussed at the meeting; and
- d). a description of any changes to the proposed DEVELOPMENT that the Director of Planning & Zoning deems necessary as a result of the meeting.

### 7. Public Notice

#### a. General

- i. Public notice of a neighborhood meeting, public meeting, or DEVELOPMENT review or legislative procedure public hearing is provided to inform the general public of the meeting or hearing and to direct interested parties to any available information concerning the DEVELOPMENT proposal.
- ii. Costs incurred by the City for public notice must be prepaid by the APPLICANT according to the review boards rules of procedure.

#### b. Mailed Notice

- i. APPLICANTS shall provide notice of a neighborhood meeting as follows:
  - a). a). mailing notice to parties in interest.
  - b). mailing notice to direct ABUTTERS;
  - c). mailing notice to PROPERTY OWNERS within three hundred (300) feet;
  - d). making best efforts to mail notice to the residents of addresses owned by parties in interest, as provided by the U.S. Postal Service;
  - e). making best efforts to hand deliver notice to each direct ABUTTER;
  - f). contacting individuals that have requested to be notified about DEVELOPMENT in the neighborhood via email or telephone; and
  - g). requesting local businesses to post notice in their establishment.
- ii. The Director of Planning & Zoning shall provide notice of a public hearing or a design review public meeting or as follows:
  - a). mailing notice to direct ABUTTERS;
  - b). mailing notice to PROPERTY OWNERS within three hundred (300) feet or five hundred (500) feet for DEVELOPMENT in the HIGH-RISE district; and
  - c). mailing notice to the Planning Board of any ABUTTING City or Town sharing a municipal boundary the City of Somerville within three hundred (300) feet of the subject property.
- iii. The Director of Planning & Zoning shall mail notice of a public hearing for a LAND CONVEYANCE to direct ABUTTERS.
- iv. The Director of Planning & Zoning shall mail notice of a public hearing for an amendment to the Somerville Zoning Ordinance or Zoning Atlas

to the Planning Board of City or Town sharing a municipal boundary with th City of Somerville, the Massachusetts Department of Housing & Community DEVELOPMENT, and the Metropolitan Area Planning Council.

#### c. Published Notice

- i. The Director of Planning & Zoning shall publish notice of a public meeting or public hearing in a newspaper of general circulation in the City of Somerville and the City of Somerville website no less than fourteen (14) days in advance of the scheduled hearing date, with a second notice the following week.

#### d. Posted Notice

- i. The Director of Planning & Zoning shall post notice of a design review or neighborhood meeting in a conspicuous place in City Hall no less than seven (7) days in advance of the scheduled meeting date.
- ii. The Director of Planning & Zoning shall post notice of a DEVELOPMENT review or legislative procedure public hearing in a conspicuous place in City Hall no less than fourteen (14) days in advance of the scheduled hearing date.
- iii. The Director of Planning & Zoning shall post notice of a DEVELOPMENT review public hearing in a conspicuous place at the subject property no less than fourteen (14) days in advance of the scheduled meeting date.

#### e. Appeal for Improper Notice

- i. Any aggrieved party may appeal the decision of any review board or official when claiming improper notice of a DEVELOPMENT review public hearing or meeting according to the procedures of §15.5.3 Judicial Appeal.
- ii. Judicial appeals claiming improper notice of a DEVELOPMENT review public hearing or meeting must be filed per MGL 40A.

### 8. Public Hearing

#### a. Procedure

- i. A public hearing must be held within sixty-five (65) days after receiving a completed development review application that requires a Special Permit, Master plan Special Permit, HARDSHIP Variance, Site Plan Approval, or SUBDIVISION Plan Approval.
- ii. A public hearing must be held within ninety (90) days after receiving a completed development review application that requires a Neighborhood DEVELOPMENT Plan Approval.

#### b. Hearing Administration

- i. Public hearings are conducted in accordance with the procedures set forth in M.G.L. Chapter 40A, as amended; any and all requirements of The Code of Ordinances, City of Somerville, Massachusetts;

- and the rules of the applicable review board.
- c. Access to Documents
  - i. The Director of Planning & Zoning shall post all relevant development review application materials on the City website prior to the notice of a public hearing.
  - ii. Physical copies of application information, DEVELOPMENT plan documentation, and other related correspondence are available to inspect or copy by any party upon reasonable request and payment of a fee to cover the cost of such copies.
- d. Continuance
  - i. Upon mutual agreement by the APPLICANT and a four-fifths majority of the review board, the following procedural requirements may be extended:
    - a). the time limit required for commencement of a public hearing;
    - b). the time limit required to make a decision.
  - ii. Mutual agreement of extended time limits must be recorded in writing.

**9. Decision**

- a. Action by a Review Board
  - i. Within ninety (90) days of the closing of a public hearing, the review board must
    - a). make a decision to approve, approve with conditions, deny, or grant withdrawal the application for a Special Permit; and
    - b). file that decision with the Office of the City Clerk.
- b. Written Information
  - i. Decisions must include a detailed record of the proceedings of the public hearing, indicate the vote of each board member, the reason for the board's decision, and identify any official actions taken by the board and conditions attached to the approval.
- c. Notice of the Decision
  - i. The Director of Planning & Zoning shall mail notification of the decision to the petitioner, APPLICANT, or appellant, as applicable.
- d. Filing of the Decision
  - i. Decisions must be filed with the Office of the City Clerk within fourteen (14) days of the review board making the decision. The City Clerk will date stamp the decision, beginning the time period for which an appeal may be filed.

**10. Appeal**

- a. Appeals of a decision by the BUILDING OFFICIAL, Director of Planning & Zoning, Zoning Board of Appeals, or Planning Board must be carried out in accordance with Section 15.2 Discretionary Permits, Section 15.3 Administrative Permits, and Section 15.5 Appeals of this Article.

**11. Certification of Decision**

- a. After the time period for an appeal has expired (see Section 15.5 Appeals), the APPLICANT must take a copy of the decision provided by the Planning Division to the Office of the City Clerk for certification that no appeals have been filed.
- b. Once the Office of the City Clerk has certified that the decision has not been appealed, or certified that the decision was appealed and the APPLICANT decides to proceed at risk, the APPLICANT must archive the decision with the property authority as follows:
  - i. For unregistered land, the APPLICANT must submit the certified copy of the decision to the Middlesex South Registry of Deeds.
  - ii. For registered land, the APPLICANT must submit the certified copy of the decision to the Land COURT.

**12. Certificate of Zoning Compliance**

- a. The BUILDING OFFICIAL shall grant a Certificate of Zoning Compliance for DEVELOPMENT that conforms to the provisions and procedures of this Ordinance.
- b. No certificate of zoning compliance will be issued without physical evidence that the certified copy of the decision has been properly filed with the Middlesex South Registry of Deeds or Land COURT.

# 15. ADMINISTRATION

## Discretionary Permits

### 15.2 DISCRETIONARY PERMITS

#### 1. Special Permit

- a. Purpose
  - i. A Special Permit authorizes DEVELOPMENT that is not otherwise permitted, provided that it meets certain criteria set out in this Ordinance.
- b. Applicability
  - i. Special Permits are required for DEVELOPMENT as indicated elsewhere in this Ordinance.
  - ii. The granting of a Special Permit authorizes the BUILDING OFFICIAL to issue a certificate of zoning compliance for DEVELOPMENT that is otherwise compliant with the provisions and procedures of this Ordinance.
  - iii. The BUILDING OFFICIAL may not issue a certificate of zoning compliance for DEVELOPMENT that requires a Special Permit until a Special Permit has been granted by the review board in accordance with the provisions of this Article.
- c. Authority
  - i. The review board serving as the decision making authority for a Special Permit is determined by zoning district.
- d. Procedure
  - i. The following review procedures are required:
    - a). Step 1: Development Review Application
    - b). Step 2: Application Review & Staff Report
    - c). Step 3: Public Notice
    - d). Step 4: Public Hearing
    - e). Step 5: Decision
    - f). Step 6: Appeal Period
    - g). Step 7: Certification of Decision
    - h). Step 8: Certificate of Zoning Compliance
  - ii. The following additional review procedures are required prior to Step 1: Development Review Application for all USE Special Permits, changes to nonconforming USES, DEVELOPMENT seeking MODIFICATION to the minimum or maximum parking standards, and all MODIFICATIONS to nonconforming structures:
    - a). Pre-Submittal Meeting
    - b). Neighborhood Meeting
  - iii. The review procedures required for a Special Permit may, at the discretion of the designated review board, be conducted simultaneously with the review procedures required for other discretionary or administrative permits.
  - iv. The procedures required for Special Permits that are necessitated by phases of DEVELOPMENT subject to a Master Plan Special Permit may be conducted concurrently with the procedures required for a Master Plan Special Permit at the discretion of the review board.
- e. Review Criteria
  - i. In its discretion to approve or deny a Special Permit required by this Ordinance, the review board shall make findings considering, at least, each of the following:
    - a). The COMPREHENSIVE PLAN and existing policy plans and standards established by the City.
    - b). The intent of the zoning district where the property is located.
    - c). Considerations indicated elsewhere in this Ordinance for the required Special Permit.
  - ii. When considering a revision to a previously approved development review application that required a Special Permit, the review board shall limit their review to the proposed changes to the previously approved application.
- f. Conditions
  - i. The review board may attach conditions and limitations that it deems necessary in order to ensure compliance to the Board's findings and the standards for granting of a specific Special Permit
  - ii. Conditions must have a rational nexus to potential impacts of the proposed DEVELOPMENT, and be roughly proportional, both in nature and extent, to the impacts of the proposed DEVELOPMENT.
- g. Compliance
  - i. The Review Board may require the posting of a bond or other performance guarantee to ensure compliance with the development review application and conditions, as approved.
- h. Permit Duration and Extension
  - i. Special Permits remain valid for three (3) years from the date the decision is filed with the Office of the City Clerk, excluding any time required awaiting the decision of an appeal.
  - ii. The review board may reduce the time period that a Special Permit remains valid to a shorter time period as a condition attached to the Special Permit.
  - iii. The review board may extend the duration of validity for a Special Permit upon making a finding that a demonstrated hardship has prevented utilization of the rights authorized by the Special Permit.
  - iv. Requests for extension of the duration of validity must be submitted to the Office of the City Clerk on the appropriate forms provided by the Planning Division.
- i. Appeals
  - i. An aggrieved party may appeal the decision of the BUILDING OFFICIAL in accordance with §15.5.2. Administrative Appeal.

- ii. An aggrieved party may appeal the decision of the Zoning Board of Appeals or Planning Board in accordance with §15.5.3 Judicial Appeal.

### 2. Master Plan Special Permit

- a. Purpose
  - i. A Master Plan Special Permit authorizes a long term plan for future DEVELOPMENT and for an APPLICANT to move forward with subsequent DEVELOPMENT review required elsewhere in this Ordinance.
- b. Applicability
  - i. A Master Plan Special Permit is required for DEVELOPMENT as indicated elsewhere in the Ordinance.
  - ii. Approval of a Master Plan Special Permit authorizes the BUILDING OFFICIAL to accept applications for subsequent DEVELOPMENT review required by this Ordinance only and does not establish any vested right to develop property in accordance with the plan.
- c. Authority
  - i. The Planning Board is the decision making authority for a Master Plan Special Permit.
- d. Procedure
  - i. The following review procedures are required:
    - a). Step 1: Pre-Submittal Meeting
    - b). Step 2: Neighborhood Meeting
    - c). Step 3: Development Review Application
    - d). Step 4: Application Review & Staff Report
    - e). Step 5: Public Notice
    - f). Step 6: Public Hearing
    - g). Step 7: Decision
    - h). Step 8: Appeal Period
    - i). Step 9: Certification of Decision
    - j). Step 10: Certificate of Zoning Compliance
  - ii. The review procedures required for a Master Plan Special Permit may, at the discretion of the designated review board, be conducted simultaneously with the review procedures required for other discretionary or administrative permits, as indicated elsewhere in this Ordinance.
- e. Review Criteria
  - i. In its discretion to approve or deny a development review application requiring a Master Plan Special Permit, the Planning Board shall make findings considering, at least, each of the following:
    - a). The COMPREHENSIVE PLAN and existing policy plans and standards established by the City.
    - b). The intent of the zoning district where the property is located.
    - c). The proposed alignment and connectivity of the THOROUGHFARE network.
    - d). The GROSS FLOOR AREA allocated to different USE categories.
- e). Mitigation proposed to alleviate any adverse impacts on utility infrastructure.
- f). Proposed DEVELOPMENT phasing.
- g). Proposed on-STREET parking to address demand by customers of Retail Sales, Food & Beverage, or Commercial Services PRINCIPAL USES.
- h). Considerations indicated elsewhere in this Ordinance for the required Master Plan Special Permit.
- ii. When considering a revision to a previously approved development review application that required a Master Plan Special Permit, the review board shall limit their review to the proposed changes to the previously approved application.
- f. Conditions
  - i. The review board may attach conditions and limitations that it deems necessary in order to ensure compliance to the Board's findings and the standards for granting of a Special Permit.
  - ii. Conditions must have a rational nexus to potential impacts of the proposed DEVELOPMENT, and be roughly proportional, both in nature and extent, to the impacts of the proposed DEVELOPMENT.
  - iii. The Planning Board shall require APPLICANTS to provide for infrastructure mitigation, transportation mitigation, and community impact mitigation as a condition of an any Master Plan Special Permit.
  - iv. The Planning Board shall establish construction permitting requirements for the phasing of DEVELOPMENT, if applicable, as a condition of any Master Plan Special Permit.
- g. Compliance
  - i. The Review Board may require the posting of a bond or other performance guarantee to ensure compliance with the development review application and conditions, as approved.
- h. Permit Duration and Extension
  - i. Master Plan Special Permits remain valid for three (3) years from the date the decision is filed with the Office of the City Clerk, excluding any time required awaiting the decision of an appeal, and remain valid so long as progress is being made in accordance with the approved phasing of DEVELOPMENT.
  - ii. The review board may reduce the time period that a Master Plan Special Permit remains valid to a shorter time period as a condition attached to the permit.
  - iii. The review board may extend the duration of validity for a Master Plan Special Permit upon making a finding that a demonstrated hardship has prevented utilization of the rights authorized by the



# 15. ADMINISTRATION

## Discretionary Permits

Special Permit.

- iv. Requests for extension of the duration of validity must be submitted to the Office of the City Clerk on the appropriate forms provided by the Planning Division.

- i. Appeals

- i. An aggrieved party may appeal the decision of the BUILDING OFFICIAL in accordance with §15.5.2. Administrative Appeal.
- ii. An aggrieved party may appeal the decision of the Zoning Board of Appeals or Planning Board in accordance with §15.5.3. Judicial Appeal.

### 3. Hardship Variance

- a. Purpose

- i. A HardSHIP Variance authorizes DEVELOPMENT that would otherwise be prohibited by the provisions of this Ordinance, due to hardSHIP.

- b. Applicability

- i. A HardSHIP Variance is required for DEVELOPMENT that is not compliant with the provisions of this Ordinance.
- ii. The granting of a HardSHIP Variance authorizes the BUILDING OFFICIAL to issue a certificate of zoning compliance for DEVELOPMENT that is otherwise compliant with the provisions and procedures of this Ordinance.
- iii. The BUILDING OFFICIAL may not issue a certificate of zoning compliance for DEVELOPMENT that requires a HardSHIP Variance until a HardSHIP Variance has been granted by the review board in accordance with the provisions of this Article.
- iv. USE HardSHIP Variances are not permitted.

- c. Authority

- i. The Zoning Board of Appeals is the review board for all HardSHIP Variances.

- d. Procedure

- i. The following review procedures are required:
  - a). Step 1: Pre-Submittal Meeting
  - b). Step 2: Development Review Application
  - c). Step 3: Application Review & Staff Report
  - d). Step 4: Public Notice
  - e). Step 5: Public Hearing
  - f). Step 6: Decision
  - g). Step 7: Appeal Period
  - h). Step 8: Certification of Decision
  - i). Step 9: Certificate of zoning compliance
- ii. The following steps may be required prior to Step 2 Development Review Application submittal at the discretion of the Director of Planning & Zoning or Review Boards:
  - a). Neighborhood Meeting
  - b). Design Review
- iii. The review procedures required for a HardSHIP

Variance may, at the discretion of the designated review board, be conducted simultaneously with the review procedures required for other discretionary or administrative permits.

- e. Review Criteria

- i. The Zoning Board of Appeals may only grant a HardSHIP Variance upon finding all of the following:
  - a). Special circumstances exist relating to the soil conditions, shape, or topography of a PARCEL of land or the unusual character of an existing structure but not affecting generally the zoning district in which the land or structure is located;
  - b). Literal enforcement of the provision of this Ordinance for the district where the subject land or structure is located would involve substantial hardSHIP, financial or otherwise, to the petitioner or appellant due to said special circumstances; and
  - c). Desirable relief could be granted without causing substantial detriment to the public good and without nullifying or substantially derogating from the intent and purpose of a specific district in this Ordinance or the Ordinance in general.
- ii. When considering a revision to a previously approved development review application that required a HardSHIP Variance, the review board shall limit their review to the proposed changes to the previously approved application.

- f. Conditions

- i. The Zoning Board of Appeals may attach conditions and limitations that it deems necessary in order to ensure compliance to the Board's findings and the standards for granting of a HardSHIP Variance.
- ii. Conditions must have a rational nexus to potential impacts of the proposed DEVELOPMENT, and be roughly proportional, both in nature and extent, to the impacts of the proposed DEVELOPMENT.

- g. Compliance

- i. The Zoning Board may require the posting of a bond or other performance guarantee to ensure compliance with the development review application and conditions, as approved.

- h. Duration and Extension

- i. HardSHIP Variances remain valid for one (1) year from the date the decision is made by the Zoning Board of Appeals, not the date that the decision is filed with the Office of the City Clerk, excluding any time required awaiting the decision of an appeal.
- ii. Upon written request by an APPLICANT, the Zoning Board of Appeals may, in its discretion, extend the time period that a HardSHIP Variance remains valid for up to six (6) months.
- iii. Requests for extension of a HardSHIP Variance must



be submitted to the Office of the City Clerk on the appropriate forms provided by the BUILDING OFFICIAL.

i. Appeals

- i. An aggrieved party may appeal the decision of the BUILDING OFFICIAL in accordance with §15.5.2. Administrative Appeal.
- ii. An aggrieved party may appeal the decision of the Zoning Board of Appeals according to the procedures of §15.5.3. Judicial Appeal.

#### 4. Plan Revision

a. Purpose

- i. Plan revision allows an APPLICANT to revise the nature of a development review application that is subject to a previously approved Discretionary or administrative permit.

b. Applicability

- i. Revisions to a previously approved development review application may be submitted by an APPLICANT in accordance with the provisions of this section.

c. Authority

- i. The Director of Planning & Zoning is the decision making authority for a Plan Revision.

d. Procedure

- i. The following review procedures are required:
  - a). Step 1: Pre-Submittal Meeting
  - b). Step 2: Development Review Application
- ii. Within fourteen (14) days after revision to a previously approved development review application, the Director of Planning & Zoning must review the application and determine if the proposed revision is de minimus or significant enough to be considered a major amendment to the original proposal.
- iii. Upon a determination that the proposed revision is de minimus, the Director of Planning & Zoning will approve or deny the proposed revisions in writing.
- iv. Upon a determination that the proposed revision is a major amendment, the Director of Planning & Zoning shall notify the APPLICANT, in writing, and forward the revised application to the designated review board as a revision to a previously approved development review application.

e. Review Criteria

- i. The Director of Planning & Zoning may determine the proposed revision is de minimus upon finding that the revised application:
  - a). Does not contravene the previously published public notice, any finding, or attached condition made by the review board for the original development review application;
  - b). Does not detrimentally impact matters of substance identified in the meeting minutes of

the original public meetings or public hearings;

- c). Features changes that are insignificant to the degree that persons familiar with the original application would not notice a substantial change in operational or built outcome.
  - ii. When considering a revision to a previously approved development review application, the Review Boards shall limit their review to only the changes to the previously approved application.
- f. Conditions
- i. The Director of Planning & Zoning may attach conditions and limitations that are deemed necessary in order to ensure compliance to a de minimus revised development review application.
  - ii. Conditions must have a rational nexus to potential impacts of the proposed DEVELOPMENT, and be roughly proportional, both in nature and extent, to the impacts of the proposed DEVELOPMENT.
- g. Appeals
- i. An aggrieved party may appeal the decision of the Director of Planning & Zoning according to the procedures of §15.5.2. Administrative Appeal.

# 15. ADMINISTRATION

## Administrative Permits

### 15.3 ADMINISTRATIVE PERMITS

#### 1. Subdivision Plan Approval

- a. Purpose
    - i. SUBDIVISION Plan Approval certifies that a final plat plan showing the division(s) of a PARCEL of land into new LOTS and the THOROUGHFARES that provide ACCESS to them conforms to the provisions of this Ordinance.
    - ii. The SUBDIVISION Plan Approval process provides APPLICANTS with the opportunity to submit a preliminary plat plan to identify potential issues and the need for WAIVERS prior to the submittal of a more detailed final plat plan.
  - b. Applicability
    - i. Per Chapter 288 of the Acts of 1993, the provisions of M.G.L. 41, 81K through 81GG, inclusive, do not apply to the City of Somerville.
    - ii. No person shall subdivide any land within the City of Somerville, proceed with the improvement or sale of LOTS, construct THOROUGHFARES, install utility services, or undertake preliminary SITE preparation, such as clearing of land or excavation, in a DEVELOPMENT SITE requiring SUBDIVISION Plan Approval until a final plat plan has been submitted to, approved, and endorsed by the designated review board and recorded in the Registry of Deeds or Land COURT in accordance with the provisions of this Article.
    - iii. Granting of a SUBDIVISION Plan Approval authorizes a PROPERTY OWNER to file legal documents related to the SUBDIVISION of real estate within the city of Somerville with the Registry of Deeds or Land COURT.
    - iv. SUBDIVISION Plan Approval does not apply to LOT SPLITS, LOT MERGERS, and LOT LINE ADJUSTMENTS.
  - c. Authority
    - i. The Planning Board is the decision making authority for a SUBDIVISION Plan Approval.
  - d. Procedure
    - i. SUBDIVISION Plan Approval requires a two (2) stage permitting process that requires the submittal of a preliminary plat plan as a prerequisite to submittal of a final plat plan.
    - ii. The following review procedures are required for preliminary plat approval:
      - a). Step 1: Pre-Submittal Meeting
      - b). Step 2: Development Review Application
      - c). Step 3: Application Review & Staff Report
      - d). Step 4: Public Notice
      - e). Step 5: Public Hearing
      - f). Step 6: Decision
      - g). Step 7: Appeal Period
    - iii. The following review procedures are required for final plat approval:
      - a). Step 1: Draft & Submit Final Plat
      - b). Step 2: Planning Board Approval
      - c). Step 3: Certification of Decision
    - iv. The review procedures required for a SUBDIVISION Plan Approval may, at the discretion of the Review Board, be conducted simultaneously with the review procedures required for other discretionary or administrative permits.
  - e. Review Criteria
    - i. The Planning Board shall approve an application for SUBDIVISION Plan Approval upon verifying that the submitted plan conforms with the provisions of this Ordinance and demonstrates consistency to the following:
      - a). The COMPREHENSIVE PLAN and existing policy plans and standards established by the City.
      - b). The intent of the zoning district where the property is located.
      - c). Considerations indicated elsewhere in this Ordinance for the required SUBDIVISION Plan Approval.
    - ii. When considering a revision to a previously approved development review application that required a SUBDIVISION Plan Approval, the review board shall limit their review to the proposed changes to the previously approved application.
  - f. Conditions
    - i. The review board may attach conditions and limitations that it deems necessary in order to ensure compliance to the Board's findings and the standards for granting of a SUBDIVISION Plan Approval.
    - ii. Conditions must have a rational nexus to potential impacts of the proposed DEVELOPMENT, and be roughly proportional, both in nature and extent, to the impacts of the proposed DEVELOPMENT.
  - g. Compliance
    - i. The Review Board may require the posting of a bond or other performance guarantee to ensure compliance with the development review application and conditions, as approved.
  - h. Appeals
    - i. An aggrieved party may appeal the decision of the Planning Board according to the procedures of §15.5.3. Judicial Appeal.
- #### 2. Site Plan Approval
- a. Purpose
    - i. Site Plan Approval is the administrative review and approval of a development review application that is conforming to the provisions of this Ordinance to address any potential DEVELOPMENT impacts.
    - ii. The Site Plan Approval process provides

- an APPLICANT with the opportunity to submit architectural, SITE, landscape, and engineering plans so that compliance to the provisions of this Ordinance can be determined prior to preparation of construction documents.
  - iii. The Site Plan Approval process provides the City with the opportunity to establish conditions to address on-SITE or off-SITE impacts of DEVELOPMENT.
  - b. Applicability
    - i. Site Plan Approval is required as indicated elsewhere in this Ordinance.
    - ii. Approval of a SITE DEVELOPMENT plan authorizes the BUILDING OFFICIAL to issue a certificate of zoning compliance for DEVELOPMENT that is otherwise compliant with the provisions of this Ordinance.
    - iii. The BUILDING OFFICIAL may not issue a certificate of zoning compliance for DEVELOPMENT that requires Site Plan Approval until the Site Plan Approval process has been completed in accordance with the provisions of this Article.
  - c. Authority
    - i. The review board serving as the decision making authority for a Site Plan Approval is determined by zoning district.
  - d. Procedure
    - i. Unless otherwise specified, the following review procedures are required:
      - a). Step 1: Pre-Submittal Meeting
      - b). Step 2: Neighborhood Meeting
      - c). Step 3: Design Review Meeting
      - d). Step 4: Neighborhood Meeting
      - e). Step 5: Development Review Application
      - f). Step 6: Application Review & Staff Report
      - g). Step 7: Public Notice
      - h). Step 8: Public Hearing
      - i). Step 9: Decision
      - j). Step 10: Appeal Period
      - k). Step 11: Certification of Decision
      - l). Step 12: Certificate of Zoning Compliance
    - ii. The review procedures required for a Site Plan Approval may, at the discretion of the designated review board, be conducted simultaneously with the review procedures required for other discretionary or administrative permits.
  - e. Review Criteria
    - i. The review board shall approve an development review application requiring Site Plan Approval upon verifying that the submitted plan conforms with the provisions of this Ordinance and demonstrates consistency to the following:
      - a). The COMPREHENSIVE PLAN and existing policy plans and standards established by the City.
      - b). The intent of the zoning district where the property is located.
      - c). Mitigation proposed to alleviate any impacts attributable to the proposed DEVELOPMENT.
      - d). Considerations indicated elsewhere in this Ordinance for the required Site Plan Approval.
    - ii. The review board may reject a application for Site Plan Approval only when:
      - a). the submittal fails to furnish adequate information required for approval;
      - b). the imposition of reasonable conditions would not ensure compliance to standards, as applicable; and/or
      - c). the submittal, although proper in form, includes or creates an intractable problem so intrusive on the needs of the public in one regulated aspect or another and cannot be adequately mitigated.
    - iii. When considering a revision to a previously approved development review application that required a Site Plan Approval, the review board shall limit their review to the proposed changes to the previously approved application.
  - f. Conditions
    - i. The review board may attach conditions and limitations that it deems necessary in order to ensure compliance with the Board's findings and the standards for granting of a Site Plan Approval.
    - ii. Conditions must have a rational nexus to potential impacts of the proposed DEVELOPMENT, and be roughly proportional, both in nature and extent, to the impacts of the proposed DEVELOPMENT.
  - g. Compliance
    - i. The review board may require the posting of a bond or other performance guarantee to ensure compliance with the development review application and conditions, as approved.
  - h. Appeals
    - i. An aggrieved party may appeal the decision of the Planning Board according to the procedures of §15.5.3. Judicial Appeal.
- 3. Thoroughfare Permit**
- a. Purpose
    - i. A THOROUGHFARE Permit certifies that the construction documents for a proposed THOROUGHFARE conforms with all departmental standards and City Ordinances.
  - b. Applicability
    - i. DEVELOPMENT of any THOROUGHFARE is prohibited until a THOROUGHFARE Permit has been issued by the City Engineer.
    - ii. The City Engineer may not issue a THOROUGHFARE Permit prior to the issuance of a certificate of zoning compliance.
    - iii. The City Engineer may not issue a THOROUGHFARE

# 15. ADMINISTRATION

## Administrative Permits

Permit if construction documents do not accurately reflect the following:

- a). plans submitted for a development review application;
  - b). plans submitted for an approved discretionary or administrative permit; and
  - c). conditions attached to any discretionary or administrative permit.
- c. Authority
    - i. The City Engineer issues all THOROUGHFARE Permits.
  - d. Procedure
    - i. Within thirty (30) days after receiving a completed application for a THOROUGHFARE Permit, the City Engineer shall issue such permit, or transmit, in writing, the reasons for failure to issue such permit to the APPLICANT.
  - e. Validity
    - i. Construction must begin within six (6) months following the issuance of a THOROUGHFARE Permit and continue towards completion in a continuous and expeditious manner for the permit to remain valid.
  - f. Inspections
    - i. Submittal of a construction permit application provides consent, by the APPLICANT, for the City Engineer, or their designee, to enter upon private real property to conduct routine inspections as needed.
  - g. Appeals
    - i. Any aggrieved party may appeal an interpretation, order, requirement, direction, or failure to act by the City Engineer according to the procedures of §15.5.2. Administrative Appeal.

### 4. Civic Space Permit

- a. Purpose
  - i. A Civic Space Permit certifies that the construction documents for a proposed CIVIC SPACE conforms with all departmental standards and City Ordinances.
- b. Applicability
  - i. DEVELOPMENT of any CIVIC SPACE is prohibited until a Civic Space Permit has been issued by the Director of Public Space & Urban Forestry.
  - ii. The Director of Public Space & Urban Forestry may not issue a Civic Space Permit prior to the issuance of a certificate of zoning compliance.
  - iii. The Director of Public Space & Urban Forestry may not issue a Civic Space Permit if construction documents do not accurately reflect the following:
    - a). plans submitted for a development review application;
    - b). plans submitted for an approved discretionary or administrative permit; and
    - c). conditions attached to any discretionary or

administrative permit.

- c. Authority
  - i. The Director of Public Space & Urban Forestry issues all Civic Space Permits.
- d. Procedure
  - i. Within thirty (30) days after receiving a completed application for a Civic Space Permit, the Director of Public Space & Urban Forestry shall issue such permit, or transmit, in writing, the reasons for failure to issue such permit to the APPLICANT.
- e. Validity
  - i. Construction must begin within six (6) months following the issuance of a Civic Space Permit and continue towards completion in a continuous and expeditious manner for the permit to remain valid.
- f. Inspections
  - i. Submittal of a Civic Space Permit application provides consent, by the APPLICANT, for the Director of Public Space & Urban Forestry, or their designee, to enter upon private real property to conduct routine inspections as needed.
- g. Appeals
  - i. Any aggrieved party may appeal an interpretation, order, requirement, direction, or failure to act by the Director of Public Space & Urban Forestry according to the procedures of §15.5.2. Administrative Appeal.

### 5. Building Permit

- a. Purpose
  - i. A Building Permit certifies that the construction documents for a proposed structure conforms with the Massachusetts State Building Code 780 CMR and all applicable City Ordinances.
- b. Applicability
  - i. DEVELOPMENT of any LOT is prohibited until a Building Permit has been issued by the BUILDING OFFICIAL.
  - ii. The BUILDING OFFICIAL may not issue a Building Permit prior to the issuance of a certificate of zoning compliance.
  - iii. The BUILDING OFFICIAL may not issue a Building Permit for DEVELOPMENT if construction documents do not accurately reflect the following:
    - a). any DEVELOPMENT plan documentation submitted as part of a development review application.
    - b). conditions attached to any administrative or discretionary DEVELOPMENT review approval.
- c. Authority
  - i. The BUILDING OFFICIAL is the decision making authority for a Building Permit.
- d. Procedure
  - i. Within thirty (30) days after receiving a completed application for a Building Permit, the BUILDING OFFICIAL shall issue such permit, or transmit, in

writing, the reasons for failure to issue such permit to the APPLICANT.

- e. Validity
  - i. Construction must begin within six (6) months following the issuance of a Building Permit and continue towards completion in a continuous and expeditious manner for the permit to remain valid.
- f. Inspections
  - i. Submittal of a Building Permit application provides consent, by the APPLICANT, for the BUILDING OFFICIAL, or their designee, to enter upon private real property to conduct routine inspections as needed.
- g. Appeals
  - i. Any aggrieved party may appeal an interpretation, order, requirement, direction, or failure to act by the BUILDING OFFICIAL according to the procedures of §15.5.2. Administrative Appeal.
  - ii. Any aggrieved party may appeal an interpretation, order, requirement, direction, or failure to act by the BUILDING OFFICIAL according to the procedures of §15.5.1. Building Code Appeal.

# 15. ADMINISTRATION

## Certificates

### 15.4 CERTIFICATES

#### 1. Certificate of Zoning Compliance

- a. Purpose
  - i. A certificate of zoning compliance certifies that DEVELOPMENT plans conform to the provisions of this Ordinance and that any additional type of DEVELOPMENT review required by this Ordinance has been completed in accordance with the provisions of this Article.
- b. Authority
  - i. The BUILDING OFFICIAL issues all Certificates of Zoning Compliance.
- c. Applicability
  - i. All DEVELOPMENT requires a certificate of zoning compliance.
  - ii. The BUILDING OFFICIAL may not accept a development review application that requires a pre-submittal meeting, a neighborhood meeting, or design review until those review procedures have been completed in accordance with the provisions of this Article.
  - iii. The BUILDING OFFICIAL may not issue a certificate of zoning compliance for DEVELOPMENT that requires a discretionary or administrative permit until that permit has been granted by the appropriate review board in accordance with the provisions of this Article.
  - iv. The BUILDING OFFICIAL may not issue a Building Permit, certificate of occupancy, or construction permit prior to the issuance of a certificate of zoning compliance.
  - v. In cases where both a Building Permit and a certificate of occupancy are required, a certificate of zoning compliance is only required prior to the issuance of the Building Permit.
- d. Procedure
  - i. The BUILDING OFFICIAL shall forward development review applications that require a discretionary or administrative permit to the appropriate review board, subject to the applicable procedural requirements of this Article.
  - ii. Within ten (10) days after receiving a completed development review application that does not require a discretionary or administrative permit, the BUILDING OFFICIAL shall issue a certificate of zoning compliance, or transmit, in writing, the reasons for failure to issue such permit to the APPLICANT.
  - iii. When considering a revision to a previously approved development review application, the BUILDING OFFICIAL shall limit their review to the proposed changes to the previously approved application.
- e. Validity

- i. A certificate of zoning compliance remains valid for ninety (90) days.
- f. Review Criteria
  - i. The BUILDING OFFICIAL shall approve an application for certificate of zoning compliance upon verifying the following:
    - a). that the submitted plan conforms with the provisions of this Ordinance;
    - b). the application is consistent with all prior approvals for the subject property; and
    - c). any additional type of administrative or discretionary DEVELOPMENT review required by this Ordinance has been completed in accordance with the provisions of this Article.
- g. Inspections
  - i. Submittal of an application for a certificate of zoning compliance provides consent, by the APPLICANT, for the BUILDING OFFICIAL to enter upon private real property to conduct routine inspections as needed.
- h. Appeals
  - i. Administrative Appeal
    - a). An aggrieved party may appeal the decision of the BUILDING OFFICIAL according to the procedures of §15.5.2. Administrative Appeal.

#### 2. Certificate of Occupancy

- a. Purpose
  - i. A certificate of occupancy certifies that a building or structure is safe for OCCUPATION and/or USE according to all applicable Ordinances and that proper inspections have been carried out by the BUILDING OFFICIAL during any construction, reconstruction, alteration, repair, or DEMOLITION activities permitted pursuant to a Building Permit.
- b. Applicability
  - i. No real property may be occupied or USED and no existing USE of real property may be changed until a certificate of occupancy has been issued by the BUILDING OFFICIAL.
  - ii. The BUILDING OFFICIAL may not issue a certificate of occupancy prior to the issuance of a certificate of zoning compliance.
  - iii. The BUILDING OFFICIAL may not issue a final certificate of occupancy DEVELOPMENT that does not comply to the following:
    - a). plans submitted for a development review application;
    - b). plans submitted for an approved discretionary or administrative permit; and
    - c). conditions attached to any discretionary or administrative permit.



- iv. DEVELOPMENT is not considered complete until a final Certificate of Occupancy is issued.
- c. Authority
  - i. The BUILDING OFFICIAL reviews and approves all applications for a certificate of occupancy.
- d. Procedure
  - i. The approval or denial of a certificate of occupancy application is conducted administratively.
  - ii. Within ten (10) days after final inspection for a certificate of occupancy, the BUILDING OFFICIAL shall issue such certificate, or transmit, in writing, the reasons for failure to issue such certificate to the APPLICANT.
- e. Inspections
  - i. Submittal of a certificate of occupancy application provides consent, by the APPLICANT, for the BUILDING OFFICIAL to enter upon private real property to conduct inspections, as needed, until such certificate is issued.
- f. Appeals
  - i. Administrative Appeal
    - a). Any aggrieved party may appeal an interpretation, order, requirement, direction, or failure to act by the BUILDING OFFICIAL in accordance with the procedures of §15.5.2. Administrative Appeal.
  - ii. Building Code Appeal
    - a). Any aggrieved party may appeal an interpretation, order, requirement, direction, or failure to act by the BUILDING OFFICIAL according to the procedures of §15.5.1. Building Code Appeal.

**3. Written Interpretation**

- a. Purpose
  - i. A written interpretation is a formal explanation or clarification of the regulations of this ordinance as applied to specific cases.
- b. Applicability
  - i. A written interpretation may be requested by the public only for a pending application for DEVELOPMENT review.
  - ii. The BUILDING OFFICIAL may issue, update, or amend a written interpretation at their own initiative, without petition from the public.
  - iii. A written interpretation does not require the BUILDING OFFICIAL or any review board to reach a particular decision for any application for DEVELOPMENT review if the facts of the application, property, location, or character of the DEVELOPMENT proposal differ from those stated or assumed in a previously issued written interpretation.
  - iv. Written interpretations must be consistent with the intent and purpose of this Ordinance and may

- not contradict or override any provision of this Ordinance or any other City Ordinances.
- v. The BUILDING OFFICIAL shall update or amend any written interpretation substantive to the findings of any administrative and judicial appeal.
- c. Authority
  - i. The BUILDING OFFICIAL issues written interpretations.
- d. Procedure
  - i. The issuance of a written interpretation is conducted administratively.
  - ii. Within thirty (30) days after receiving a petition for a written interpretation, the BUILDING OFFICIAL must
    - a). review the specific provision or provisions to be interpreted and the facts of the specific situation concerning the request for an interpretation;
    - b). issue, in writing, meaningful explanation or clarification of the provision in question;
    - c). file the written interpretation with the Office of the City Clerk; and
    - d). post the written interpretation on the City WEBSITE.
  - iii. The BUILDING OFFICIAL may require further facts and information as are, in their judgment, necessary to provide a meaningful interpretation of the provision in question.
- e. Appeals
  - i. Administrative Appeal
    - a). An aggrieved party may appeal the decision of the BUILDING OFFICIAL in accordance with the procedures of §15.5.2. Administrative Appeal.

# 15. ADMINISTRATION

## Appeals

### 15.5 APPEALS

#### 1. Building Code Appeal

- a. Purpose
  - i. A building code appeal is a petition to rectify an interpretation, order, requirement, direction, or failure to act by the BUILDING OFFICIAL when an alleged error or misinterpretation has been made in the enforcement or application of the State Building Code (780 CMR).
- b. Procedure
  - i. Building code appeals must be filed with the State Building Code Appeal Board in accordance with the procedures set forth in M.G.L. Title XX, Chapter 143, Section 100, as amended.

#### 2. Administrative Appeal

- a. Purpose
  - i. An administrative appeal is a petition to rectify a failure to act, denial of a permit, decision made, or enforcement action taken by the BUILDING OFFICIAL or Director of Planning & Zoning in an administrative DEVELOPMENT review case when an alleged error or misinterpretation has been made in the enforcement or application of the provisions of this Ordinance.
- b. Authority
  - i. The Zoning Board of Appeals reviews and decides all administrative appeals.
- c. Procedure
  - i. Administrative appeals must be filed with the Office of the City Clerk within twenty (20) days after notice is served of an interpretation, order, requirement, direction, or failure to act by the BUILDING OFFICIAL or the filing of the decision of a review board.
  - ii. The following review procedures are required:
    - a). Step 1: Development Review Application
    - b). Step 2: Application Review & Staff Report
    - c). Step 3: Public Notice
    - d). Step 4: Public Hearing
    - e). Step 5: Decision
    - f). Step 6: Appeal Period
    - g). Step 7: Certification of Decision
- d. Judicial Appeal
  - i. An aggrieved party may appeal the decision of the Zoning Board of Appeals according to the procedures of §15.3. Judicial Appeal.

#### 3. Judicial Appeal

- a. Purpose
  - i. A judicial appeal is a petition to rectify the failure to act, denial of a permit, decision made, or enforcement action taken by a review board in a

discretionary DEVELOPMENT review case when an alleged error or misinterpretation has been made in the enforcement or application of the provisions of this Ordinance.

- b. Jurisdiction
  - i. Judicial appeals can be filed per MGL 40A, Sec. 17.
- c. Procedure
  - i. Judicial appeals must be filed within twenty (20) days after the filing of a decision with the Office of the City Clerk.

## **15.6 LEGISLATIVE PROCEDURES**

### **1. Land Conveyance**

- a. Purpose
  - i. A LAND CONVEYANCE petition is a request for the City to accept a voluntary offering of land for public dedication.
- b. Applicability
  - i. The approval or denial of a LAND CONVEYANCE petition is a discretionary legislative act, subject to the procedures of M.G.L 30B and other Massachusetts law.
- c. Authority
  - i. The City Council reviews and decides all LAND CONVEYANCE petitions.
- d. Procedure
  - i. Within fourteen (14) days of receiving a LAND CONVEYANCE petition, the City Council must submit the petition and accompanying plan documentation to the Planning Board for review.
  - ii. Within sixty-five (65) days after submittal to the Planning Board, the City Council must review the petition and hold a public hearing.
  - iii. Within ninety (90) days of the closing of the public hearing, the City Council must vote to accept or reject the petition to convey the voluntary offering of land for public dedication.
  - iv. If no vote is taken within ninety (90) days, the review procedure must be started de novo.
  - v. The City Council shall abstain from taking a vote until:
    - a). the Planning Board has submitted a report with recommendations concerning the petition; or
    - b). twenty-one (21) days after the closing of the public hearing without the Planning Board submitting its report.
  - vi. A two-thirds vote by all of the members of the City Council is required to accept a voluntary offering of land for public dedication.
- e. Recommendation
  - i. In developing its recommendation to the City Council, the Planning Board shall make findings considering, at least, each of the following:
    - a). the adopted COMPREHENSIVE PLAN of the City of Somerville and existing policy, plans, and standards established by the City, including the OPEN SPACE & Recreation Plan.
    - b). the purpose of the district where the property is located and of this Ordinance in general.
    - c). any demonstrated public interest in ownership and the assumption of maintenance responsibility for the land in question.
- f. Conditions
  - i. The Planning Board may make recommendations

to the City Council for conditions that it deems within the public interest in accepting a petition to convey land to the City of Somerville.

### **2. Zoning Text Amendment**

- a. Purpose
  - i. A text amendment petition is a request to change the provisions of the Somerville Zoning Ordinance in response to changes in City policy or real world conditions.
- b. Applicability
  - i. The approval or denial of a zoning text amendment is a discretionary legislative act.
- c. Authority
  - i. The City Council reviews and decides petitions to amend this Ordinance.
  - ii. The Director of Planning & Zoning may update figures and photos; correct scrivener's errors, table and figure numbers, capitalization of defined words, and cross references; and add or correct street names or districts labels for maps without City Council approval.
- d. Procedure
  - i. Petitions for a text amendment may be submitted by:
    - a). any member(s) of the City Council;
    - b). the Mayor;
    - c). the Zoning Board of Appeals;
    - d). the Planning Board;
    - e). a PROPERTY OWNER seeking to change the entitlement of his/her own property; or
    - f). ten (10) registered voters in the City of Somerville.
  - ii. Within fourteen (14) days of receiving a petition to amend the text of this Ordinance, the City Council must submit the petition and the proposed changes, additions, or repeal of language to the Planning Board for review.
  - iii. Within sixty-five (65) days after submittal to the Planning Board, the City Council must review the petition and hold a public hearing.
  - iv. Within ninety (90) days of the closing of the public hearing, the City Council must vote to adopt, reject, or amend and adopt the text amendment petition.
  - v. If no vote is taken within ninety (90) days, the review procedure must be started de novo.
  - vi. The City Council shall abstain from taking a vote until:
    - a). the Planning Board has submitted a report with recommendations concerning the petition; or
    - b). twenty-one (21) days after the closing of the

# 15. ADMINISTRATION

## Legislative Procedures

public hearing without the Planning Board submitting their report.

- vii. Proposed amendments that are denied by the City Council will not be reconsidered for a minimum of two (2) years from the date final action was taken by the Board, unless the proposed amendment is supported by a positive recommendation from the Planning Board.
- e. Recommendation
  - i. In developing its recommendation to the City Council, the Planning Board shall make findings considering, at least, each of the following:
    - a). the adopted COMPREHENSIVE PLAN of the City of Somerville and existing policy plans and standards established by the City, including the OPEN SPACE & Recreation Plan.
    - b). the purpose of the district where the property is located and of this Ordinance in general.
    - c). any demonstrated public interest in ownership and the assumption of maintenance responsibility for the land in question.

### 3. Zoning Map Amendment

- a. Purpose
  - i. A map amendment petition is a request to change how zoning districts are mapped over real property in response to changes in City policy or real world conditions.
- b. Applicability
  - i. The approval or denial of a zoning map amendment is a discretionary legislative act.
- c. Authority
  - i. The City Council reviews and decides petitions to amend the Official Zoning Map.
- d. Procedure
  - i. Petitions may be submitted by:
    - a). any member(s) of the City Council;
    - b). the Mayor;
    - c). the Zoning Board of Appeals;
    - d). the Planning Board;
    - e). a PROPERTY OWNER seeking to change the entitlement of his/her own property; and
    - f). ten (10) registered voters in the City of Somerville.
  - ii. Within fourteen (14) days of receiving a petition to amend the Official Zoning Map, the City Council must submit the petition and the proposed changes, additions, or repeal of language to the Planning Board for review.
  - iii. Within sixty-five (65) days after submittal to the Planning Board, the City Council must review the petition and hold a public hearing.
  - iv. Within ninety (90) days of the closing of the public hearing, the City Council must vote to adopt,

reject, or amend and adopt the map amendment petition.

- v. If no vote is taken within ninety (90) days, the review procedure must be started de novo.
- vi. The City Council shall abstain from taking a vote until:
  - a). the Planning Board has submitted a report with recommendations concerning the petition; or
  - b). twenty-one (21) days after the closing of the public hearing without the Planning Board submitting its report.
- vii. Proposed amendments that are denied by the City Council will not be reconsidered for a minimum of two (2) years from the date final action was taken by the Board, unless the proposed amendment is supported by a positive recommendation from the Planning Board.
- e. Recommendation
  - i. In developing its recommendation to the City Council, the Planning Board shall make findings considering, at least, each of the following:
    - a). the adopted COMPREHENSIVE PLAN of the City of Somerville and existing policy plans and standards established by the City;
    - b). the purpose of this Ordinance in general; and
    - c). the intent and purpose of the district(s) that would be applied to the properties in question.

**15.7 REVIEW BOARDS & OFFICIALS**

**1. Building Official**

- a. Responsibilities
  - i. The BUILDING OFFICIAL is the enforcement authority for this Ordinance.
  - ii. The BUILDING OFFICIAL may issue any enforcement order, violation notice, request for compliance, or other correspondence as necessary and institute any appropriate inspection, action, or proceeding in the name of the City of Somerville to:
    - a). prevent the unlawful ERECTION, relocation, extension, enlargement, or alteration of any structure or SIGN;
    - b). prevent the unlawful USE or occupancy of real property;
    - c). prevent any illegal act, business, or USE in or about any premises; and
    - d). prevent, correct, restrain, or abate violations of this Ordinance.
  - iii. The BUILDING OFFICIAL establishes application forms, fees, and requirements for DEVELOPMENT review in collaboration with the Director of Planning & Zoning and the review boards.
  - iv. The BUILDING OFFICIAL may classify certain home improvements intended to keep an existing structure in good physical condition to be NORMAL MAINTENANCE, as defined in this Ordinance
- b. Enforcement Actions
  - i. The BUILDING OFFICIAL shall not issue any written interpretation, certificate of zoning compliance, Building Permit, or certificate of occupancy in violation of this Ordinance.
  - ii. Any written interpretation, certificate of zoning compliance, Building Permit, or certificate of occupancy may be revoked upon finding any material misstatement of fact or misrepresentation in plans or specifications by an APPLICANT.
  - iii. Upon finding evidence of a violation of this Ordinance, the BUILDING OFFICIAL shall give written notice to the PROPERTY OWNER demanding that the violation be corrected or abated within a time period deemed appropriate by the BUILDING OFFICIAL.
  - iv. The BUILDING OFFICIAL shall revoke any existing certificate of occupancy or Building Permit already in effect for any property that is in violation of this Ordinance if that violation is not corrected or abated within the required time period.

**2. Zoning Board of Appeals**

- a. Establishment
  - i. The Zoning Board of Appeals is established, in accordance with M.G.L. Chapter 40A, Section 12, as amended.

- b. Membership
  - i. The Mayor shall appoint five (5) members and two (2) alternate members, subject to confirmation of the City Council.
  - ii. Members of the Zoning Board of Appeals are appointed for five (5) year terms.
- c. Responsibilities
  - i. The Zoning Board of Appeals is the decision making authority for discretionary and administrative permitting as indicated elsewhere in this Ordinance.
  - ii. The Zoning Board of Appeals is the decision making authority for administrative appeals.
- d. Board Rules
  - i. The Zoning Board of Appeals shall elect, at least, a chair and a vice chair on an annual basis from among its own number.
  - ii. The chair of the Zoning Board of Appeals shall designate an alternate member to sit in the place of any member incapacitated by personal interest, inability to act, or absence when necessary.
  - iii. The Zoning Board of Appeals, or its designee, shall keep minutes of its proceedings.
  - iv. The Zoning Board of Appeals may adopt rules of procedure and policy as it deems necessary to conduct its affairs, including but not limited to the following subjects:
    - a). rules and procedures governing applications and fees, including required written and graphical information;
    - b). rules and procedures pertaining to the DEVELOPMENT review process;
    - c). rules and procedures of a minor a Site Plan Approval process for DEVELOPMENT activities that do not require the procedural steps for Site Plan Approval, but that are still deserving of plan review.
  - v. The adoption or amendment of rules of procedure and policy is conducted administratively at a public meeting.

**3. Planning Board**

- a. Establishment
  - i. The Planning board is established by Chapter 2, Article 5, Division 5 of the City of Somerville Code of Ordinances, as authorized by M.G.L. Chapter 41, Section 81A-81J, as amended.
- b. MEMBERSHIP
  - i. The Mayor shall appoint five (5) members and two (2) alternate members, subject to confirmation by the City Council.
  - ii. Members of the Planning Board are appointed for three (3) year terms.
  - iii. The Planning Board, subject to appropriation and

# 15. ADMINISTRATION

## Review Boards & Officials

subject to the approval of the Mayor, may employ such technical and other assistants as may be necessary to perform its duties.

- c. Responsibilities
  - i. The Planning Board is the decision making authority for discretionary or administrative permits as indicated elsewhere in this Ordinance.
  - ii. The Planning Board, or its designee, is responsible for the authoring, adoption, and periodic updating of the COMPREHENSIVE PLAN for the City of Somerville per M.G.L. 41, 81D.
  - iii. The Planning Board, or its designee, drafts the official map of the City of Somerville per M.G.L. 41, 81E-J.
  - iv. The Planning Board provides advice and recommendations to the City Council concerning the following:
    - a). proposed amendments to the text or maps of the Somerville Zoning Ordinance;
    - b). proposed changes to the official map of the City of Somerville; and
    - c). the laying out, alteration, relocation, or discontinuance of THOROUGHFARES; and
    - d). the proposed conveyance of land to the City.
  - v. The Planning Board adopts an urban design framework each for sub area within the Master Planned DEVELOPMENT overlay district.
- d. Board Rules
  - i. The Planning Board shall elect, at least, a chair and a vice-chair on an annual basis from among its own number.
  - ii. The chair of the Planning Board shall designate an alternate member to sit in the place of any member incapacitated by personal interest, inability to act, or absence when necessary.
  - iii. The Planning Board, or its designee, shall keep minutes of its proceedings.
  - iv. The Planning Board may adopt rules of procedure and policy as it deems necessary to conduct its affairs, including but not limited to the following subjects:
    - a). rules and procedures governing applications and fees, including required written and graphical information;
    - b). rules and procedures pertaining to the DEVELOPMENT review process;
    - c). rules and procedures for a minor a Site Plan Approval process for DEVELOPMENT activities that do not require the procedural steps for Site Plan Approval, but that are still deserving of plan review.
    - d). rules and procedures for SUBDIVISION, LOT SPLITS, LOT MERGERS, and LOT LINE ADJUSTMENTS.
  - v. The adoption or amendment of rules of procedure

and policy is conducted administratively at a public meeting.

## 4. Urban Design Commission

- a. Establishment
  - i. This section establishes the Urban Design Commission.
- b. MEMBERSHIP
  - i. The Mayor shall appoint five (5) members and two (2) alternate members, subject to confirmation by the City Council.
  - ii. Members of the Urban Design Commission are appointed for five (5) year terms.
  - iii. Members and alternate members of the Urban Design Commission must have professional degrees or experience in architecture, urban design, transportation engineering, landscape architecture, or urban planning.
- c. Responsibilities
  - i. The Urban Design Commission provides advice and recommendations to the Zoning Board of Appeals and Planning Board concerning how the design of DEVELOPMENT projects affects the quality of Somerville's PUBLIC REALM.
  - ii. The Urban Design Commission provides advice and recommendations to Staff when required by a condition of a discretionary or administrative DEVELOPMENT review decision.
- d. Board Rules
  - i. The Director of Planning & Zoning and the Director of PUBLIC REALM & Urban Forestry, or their designee(s), shall serve as non-voting, administrative co-chairs.
  - ii. The co-chairs of the Urban Design Commission shall designate an alternate member to sit in the place of any member incapacitated by personal interest, inability to act, or absence when necessary.
  - iii. The Urban Design Commission, or its designee, shall keep minutes of its proceedings.
  - iv. The Urban Design Commission may adopt rules of procedure and policy as it deems necessary to conduct its affairs, including but not limited to the following subjects:
    - a). rules and procedures pertaining to the design review process, including information and materials provided by APPLICANTS and requirements for presentations made to the commission.
  - v. The adoption or amendment of rules of procedure and policy is conducted administratively at a public meeting.