

4 MID-RISE DISTRICTS

4.1	MID-RISE 3 (MR3)	111	4.4	MID-RISE 6 (MR6)	195
	Description	111		Character Description	195
	Intent	112		Intent	196
	Purpose	112		Purpose	196
	Applicability	112		Applicability	196
	Development Review	112		Development Review	196
	Building Types	112		Building Types	196
	Building Components	125		Building Components	213
	Facade Design	130		Facade Design	218
	Architectural Design Guidelines	130		Architectural Design Guidelines	218
	Use Provisions	132		Use Provisions	220
	Development Standards	134		Development Standards	222
	Parking & Mobility	135		Parking & Mobility	223
	Public Realm	135		Public Realm	223
4.2	MID-RISE 4 (MR4)	139			
	Character Description	139			
	Intent	140			
	Purpose	140			
	Applicability	140			
	Development Review	140			
	Building Types	140			
	Building Components	153			
	Facade Design	158			
	Architectural Design Guidelines	158			
	Use Provisions	160			
	Development Standards	162			
	Parking & Mobility	163			
	Public Realm	163			
4.3	MID-RISE 5 (MR5)	167			
	Description	167			
	Intent	168			
	Purpose	168			
	Applicability	168			
	Development Review	168			
	Building Types	168			
	Building Components	181			
	Facade Design	186			
	Architectural Design Guidelines	186			
	Use Provisions	188			
	Development Standards	190			
	Parking & Mobility	191			
	PUBLIC REALM	191			

4.1 MID-RISE 3 (MR3)

1. Description

The Mid-Rise 3 district is characterized by a variety of moderate FLOOR PLATE buildings up to three (3) stories in height. Buildings are set close to the sidewalk to create a defined STREET wall that supports pedestrian activity and a sense of place. The district is primarily commercial, with GROUND STORY USES that typically address the needs of residents and employees in the immediate neighborhood.



4. MID-RISE DISTRICTS

Mid-Rise 3 (MR3)

2. Intent

- a. To implement the objectives of the COMPREHENSIVE PLAN of the City of Somerville.
- b. To create, maintain, and enhance areas appropriate for smaller scale, multi-USE and mixed-USE buildings and neighborhood serving commercial USES.

3. Purpose

- a. To permit the DEVELOPMENT of multi-unit and mixed-USE buildings that do not exceed three (3) stories in height.
- b. To provide quality commercial spaces and permit small-scale, neighborhood serving commercial USES.
- c. To create DWELLING UNIT types, sizes, and BEDROOM counts ideal for larger households in apartment buildings.
- d. To create DWELLING UNIT types, sizes, and BEDROOM counts ideal for smaller households in general buildings.
- e. To permit increased residential density for buildings that meet the definition of a NET ZERO BUILDING or 100% AFFORDABLE HOUSING.

4. Applicability

- a. The section is applicable to all real property within the Mid-Rise 3 district as shown on the maps of the Official Zoning Atlas of the City of Somerville.

5. Development Review

- a. DEVELOPMENT review is subject to the provisions of Article 15: Administration of this Ordinance.
- b. All DEVELOPMENT, excluding NORMAL MAINTENANCE, requires the submittal of a development review application to the BUILDING OFFICIAL and the issuance of a Certificate of Zoning Compliance prior to the issuance of a BUILDING Permit or Certificate of Occupancy.
- c. Proposed DEVELOPMENT may or may not necessitate the need for SUBDIVISION Plan Approval, Subdivision Plan Approval, Site Plan Approval, a Special Permit, or a Hardship Variance based on the nature of the proposal. In such cases, additional DEVELOPMENT review is required in accordance with Article 15: Administration.
 - i. The Planning Board is the decision making authority for all DEVELOPMENT that requires Site Plan Approval or a Special Permit.
 - ii. The Zoning Board of Appeals is the Review Board for all HardSHIP Variances.
- d. Upon verification that no additional DEVELOPMENT review is necessary, or completion of the required DEVELOPMENT review, The BUILDING OFFICIAL shall issue a Zoning Compliance Certificate to certify compliance with the provisions and procedures of this Ordinance.

6. Building Types

- a. One (1) PRINCIPAL BUILDING TYPE is permitted on each LOT.
- b. The following BUILDING TYPES are permitted by Site Plan Approval in the Mid-Rise 3 district:
 - i. Apartment Building
 - ii. General Building
 - iii. Commercial Building
- c. Apartment Buildings are prohibited on any LOT fronting a PEDESTRIAN STREET.
- d. ACCESSORY structures are regulated according to Article 10: DEVELOPMENT Standards of this Ordinance.

4.1.7 Apartment Building

A small to moderate FLOOR PLATE, multi-STORY, PRINCIPAL BUILDING TYPE purpose built for OCCUPATION by residential USES on all stories.

The following images are examples of the apartment BUILDING TYPE and are intended only for illustrative purposes.



4. MID-RISE DISTRICTS

Mid-Rise 3 (MR3)

4.1.7. Apartment Building (continued)

a. LOT Standards

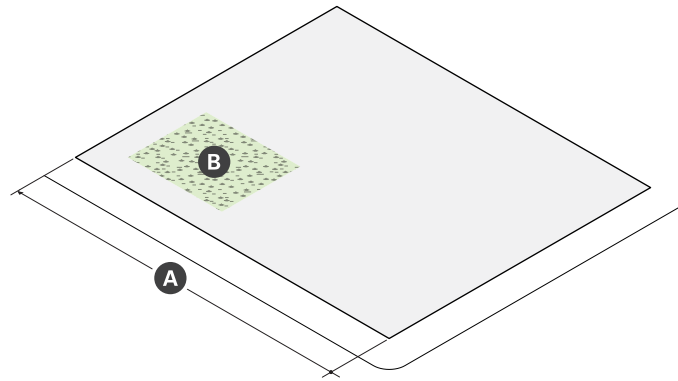

Lot Dimensions	
A LOT WIDTH (min)	30 ft

Lot Development	
LOT Coverage (max)	90%
GREEN SCORE	--
Minimum	0.25
Ideal	0.30
B OPEN SPACE (min)	15%

b. BUILDING Placement

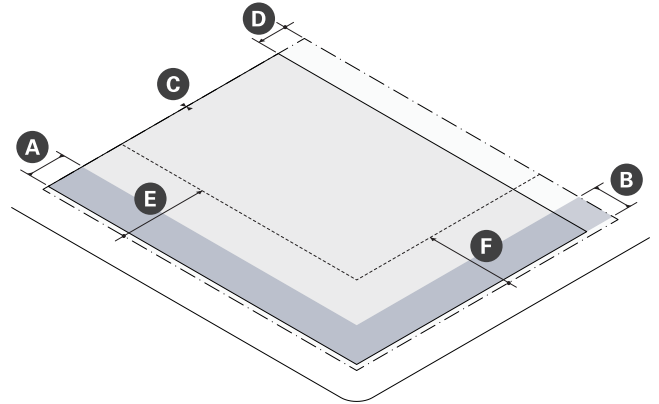

Building Setbacks		
A Primary Front SETBACK (min/max)	2 ft	12 ft
B Secondary Front SETBACK (min/max)	2 ft	12 ft
C Side SETBACK (min)	0 ft	
Side SETBACK ABUTTING NR or LHD (min)	10 ft	
D Rear SETBACK (min)	--	
ALLEY	0 ft	
No ALLEY	10 ft	
No ALLEY & ABUTTING NR or LHD	15 ft	

Parking Setbacks	
E Primary Front SETBACK (min)	--
SURFACE PARKING	30 ft
STRUCTURED PARKING	30 ft
F Secondary Front SETBACK (min)	--
SURFACE PARKING	10 ft
STRUCTURED PARKING	2 ft

4.1.7. Apartment Building (continued)

c. Massing & Height

d. Uses & Features

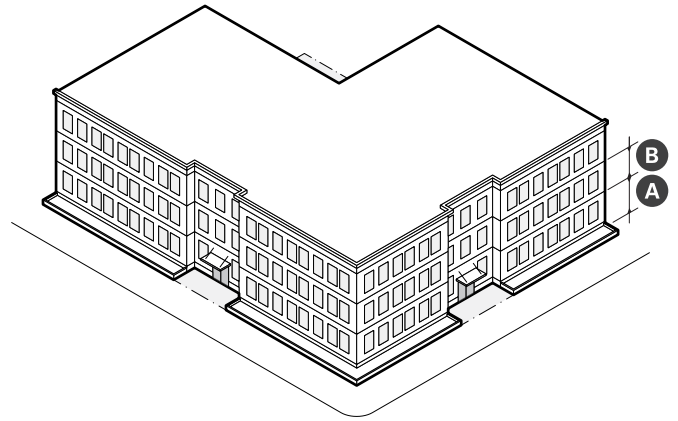
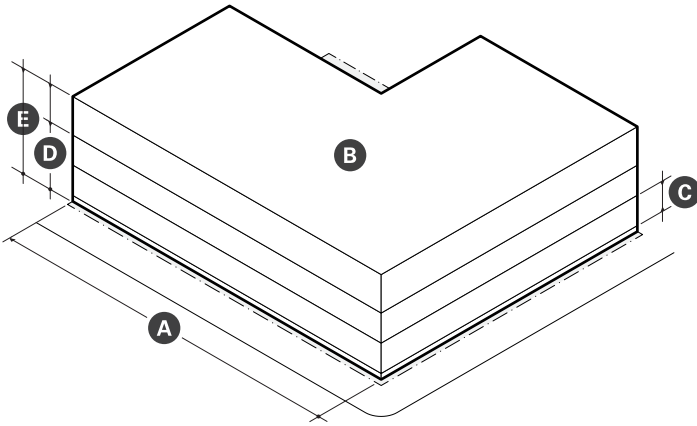

Main Massing	
A BUILDING WIDTH (max)	200 ft
FACADE Build Out (min)	--
Primary Front	80%
Secondary Front	65%
B FLOOR PLATE (max)	15,000 sf
GROUND STORY Elevation (min)	2 ft
C STORY Height (min)	10 ft
D Number of Stories (min/max)	2 3
E BUILDING Height, Feet (max)	40 ft
Roof Type	Flat

Facade Composition	
A GROUND STORY FENESTRATION (min/max)	20% 50%
B UPPER STORY FENESTRATION (min/max)	20% 50%
BLANK WALL (max)	20 ft

Use & Occupancy	
GROSS FLOOR AREA per DU	--
LOT AREA < 5,000 sf	1,500
LOT AREA >= 5,000 sf	1,125
NET ZERO BUILDING	850
100% AFFORDABLE HOUSING	850
Outdoor AMENITY SPACE (min)	1/DU

4. MID-RISE DISTRICTS

Mid-Rise 3 (MR3)

4.1.7. Apartment Building (continued)

- e. DEVELOPMENT Benefits
 - i. DEVELOPMENT of an apartment building is subject to the provisions of Article 12: DEVELOPMENT Benefits of this Ordinance. Where the provisions of this section conflict with those of Article 12, the provisions of Article 12 apply.
 - ii. DEVELOPMENT of a general building must provide AFFORDABLE DWELLING UNITS as specified on Table 4.1.7.
- f. Design Guidelines
 - i. GROUND STORY DWELLING UNITS should be elevated above the grade of any adjacent sidewalk so that the window sills of the the DWELLING UNIT are at or above the eye-level of passing pedestrians. This elevation change maintains privacy for occupants while also encouraging open blinds or curtains to allow natural daylight and ventilation into the unit.
 - ii. FENESTRATION patterns and window configurations that break the direct line of sight between neighboring properties should be utilized to every extent possible. Translucent glass on the bottom half of windows or strategically placed landscape elements should be utilized if it is not practical to off-set windows in such a way as to minimize privacy impacts.
 - iii. Outdoor AMENITY SPACES that are elevated, such as roof DECKS, fully projecting balconies, and UPPER STORY rear porches should, provide sight-obscuring visual screening at the sides to increase privacy, security, and to limit views of ABUTTING properties from elevated vantage points.

Table 4.1.7 Required ADUs

Total DWELLING UNITS	Required ADUs
0 to 5 units	None
6 units	1 unit OR fractional buyout for 0.4 units
7 units	1 unit OR fractional buyout for 0.6 units
8 to 17 units	17.5% of units
18 or more units	20% of units

4.1.8 General Building

A moderate FLOOR PLATE, multi-STORY PRINCIPAL BUILDING TYPE with GROUND STORY commercial space and no limitations on the occupancy of upper stories for permitted USES. The upper stories of a general building are typically residential, but a wide variety exists. As the number of stories increases, it becomes more likely for the upper stories of a general building to host commercial uses as well as residential.

The following images are examples of the general BUILDING TYPE and are intended only for illustrative purposes.



4. MID-RISE DISTRICTS

Mid-Rise 3 (MR3)

4.1.8. General Building (continued)

a. Lot Standards

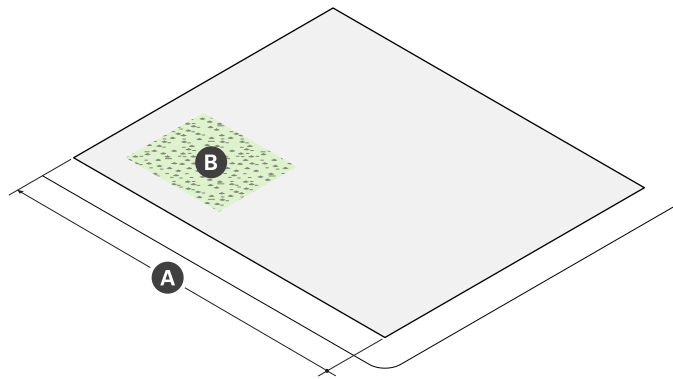

Lot Dimensions	
A LOT WIDTH (min)	30 ft

Lot Development	
LOT Coverage (max)	90%
GREEN SCORE	--
Minimum	0.25
Ideal	0.30
B OPEN SPACE (min)	15%

b. BUILDING Placement

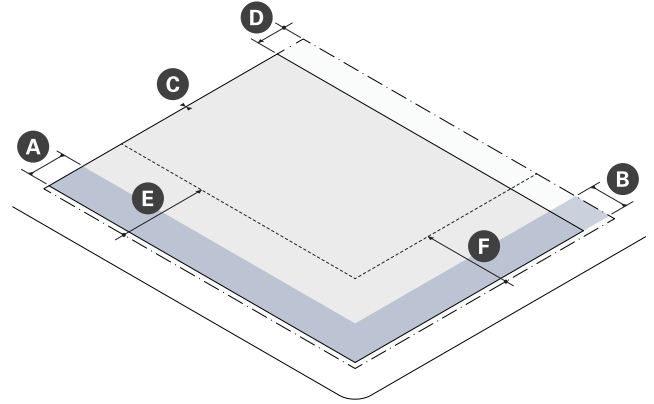

Building Setbacks		
A Primary Front SETBACK (min/max)	2 ft	12 ft
B Secondary Front SETBACK (min/max)	2 ft	12 ft
C Side SETBACK (min)	0 ft	
Side SETBACK ABUTTING NR or LHD (min)	10 ft	
D Rear SETBACK (min)	--	
ALLEY	0 ft	
No ALLEY	10 ft	
No ALLEY & ABUTTING NR or LHD	15 ft	

Parking Setbacks	
E Primary Front SETBACK (min)	--
SURFACE PARKING	30 ft
STRUCTURED PARKING	30 ft
F Secondary Front SETBACK (min)	--
SURFACE PARKING	10 ft
STRUCTURED PARKING	2 ft

4.1.8. General Building (continued)

c. Massing & Height

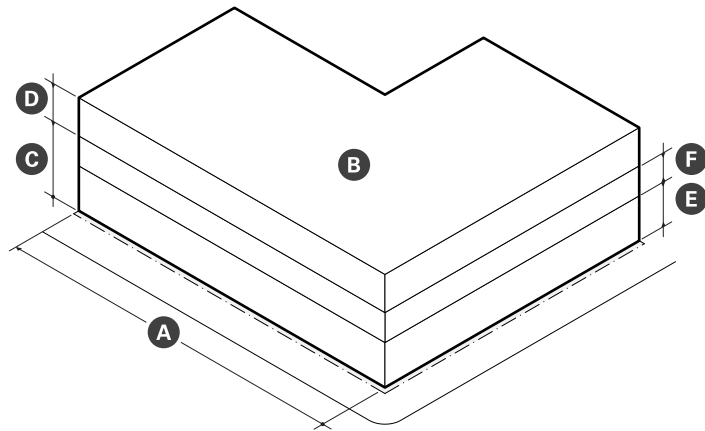

Main Massing	
A BUILDING WIDTH (max)	200 ft
FACADE Build Out, Primary Front (min)	--
Primary Front	80%
Secondary Front	65%
B FLOOR PLATE (max)	15,000 sf
C GROUND STORY Height (min)	14 ft
D UPPER STORY Height (min)	10 ft
E Number of Stories (min/max)	2 3
F BUILDING Height, Feet (max)	45 ft
Roof Type	Flat

d. Uses & Features

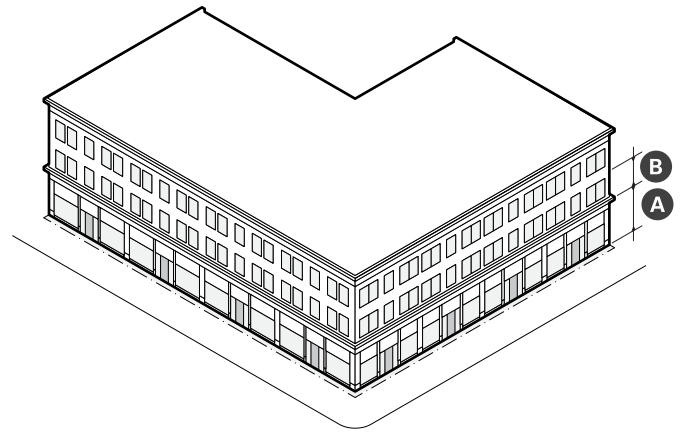

Facade Composition	
A GROUND STORY FENESTRATION (min)	70%
B UPPER STORY FENESTRATION (min/max)	20% 50%
BLANK WALL (max)	20 ft

Use & Occupancy	
GROUND STORY Entrance Spacing (max)	30 ft
Commercial Space Depth (min)	30 ft
GROSS FLOOR AREA per DU	--
LOT AREA < 5,000 sf	1,500
LOT AREA >= 5,000 sf	1,125
NET ZERO BUILDING	850
100% AFFORDABLE HOUSING	850
Outdoor AMENITY SPACE (min)	1/DU

4. MID-RISE DISTRICTS

Mid-Rise 3 (MR3)

4.1.8. General Building (continued)

- e. DEVELOPMENT Benefits
 - i. DEVELOPMENT is subject to the provisions of Article 12: DEVELOPMENT Benefits of this Ordinance. Where the provisions of this section conflict with those of Article 12, the provisions of Article 12 apply.
 - ii. DEVELOPMENT of a general building must provide AFFORDABLE DWELLING UNITS as specified on Table 4.1.8 (a).
 - iii. DEVELOPMENT of a general building must provide linkage payments as specified on Table 4.1.8. (b).
- f. Design Guidelines
 - i. FENESTRATION patterns and window configurations should break the direct line of sight between neighboring properties to every extent practicable. Translucent glass on the bottom half of windows or strategically placed landscape elements should be utilized if it is not practical to off-set windows in such a way as to minimize privacy impacts.
 - ii. Outdoor AMENITY SPACES that are elevated, such as roof DECKS, fully projecting balconies, and UPPER STORY rear porches should, provide sight-obscuring visual screening at the sides to increase privacy, security, and to limit views of ABUTTING properties from elevated vantage points.

Table 4.1.8. (a) Required ADUs

Total DWELLING UNITS	Required ADUs
0 to 5 units	None
6 units	1 unit OR fractional buyout for 0.4 units
7 units	1 unit OR fractional buyout for 0.6 units
8 to 17 units	17.5% of units
18 or more units	20% of units

Table 4.1.8 (b) Linkage

Commercial GROSS FLOOR AREA	Affordable Housing Linkage	Employment Linkage
30,000 sf or less	None	None
Over 30,000 sf	\$10/sf	\$2.46/sf

4.1.9 Commercial Building

A moderate FLOOR PLATE, multi-STORY, PRINCIPAL BUILDING TYPE purpose built for occupation by commercial USES on all stories. GROUND STORY commercial space is primarily occupied by commercial service, food & beverage service, or retail sales PRINCIPAL USES. Floor space on upper stories may be occupied by retail USES that do not rely on the visibility of a storefront at sidewalk level.

The following images are examples of the commercial BUILDING TYPE and are intended only for illustrative purposes.



4. MID-RISE DISTRICTS

Mid-Rise 3 (MR3)

4.1.9 Commercial Building (continued)

a. LOT Standards

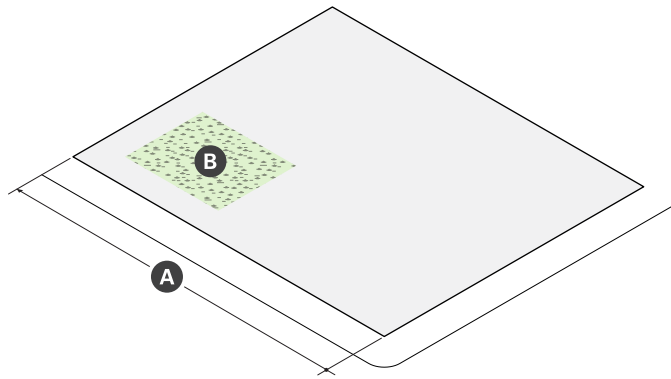

Lot Dimensions	
A LOT WIDTH (min)	30 ft

Lot Development	
LOT Coverage (max)	90%
GREEN SCORE	--
Minimum	0.25
Ideal	0.30
B OPEN SPACE (min)	15%

b. BUILDING Placement

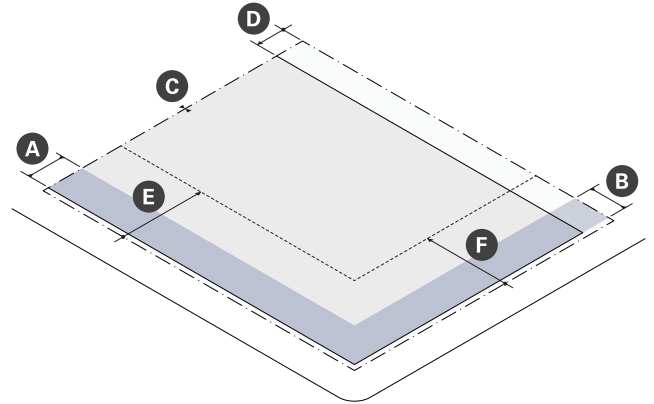

Building Setbacks		
A Primary Front SETBACK (min/max)	2 ft	12 ft
B Secondary Front SETBACK (min/max)	2 ft	12 ft
C Side SETBACK (min)	0 ft	
Side SETBACK ABUTTING NR or LHD (min)	10 ft	
D Rear SETBACK (min)	--	
ALLEY	0 ft	
No ALLEY	10 ft	
No ALLEY & ABUTTING NR or LHD	15 ft	

Parking Setbacks	
E Primary Front SETBACK (min)	--
SURFACE PARKING	30 ft
STRUCTURED PARKING	30 ft
F Secondary Front SETBACK (min)	--
SURFACE PARKING	10 ft
STRUCTURED PARKING	2 ft

4.1.9 Commercial Building (continued)

c. Massing & Height

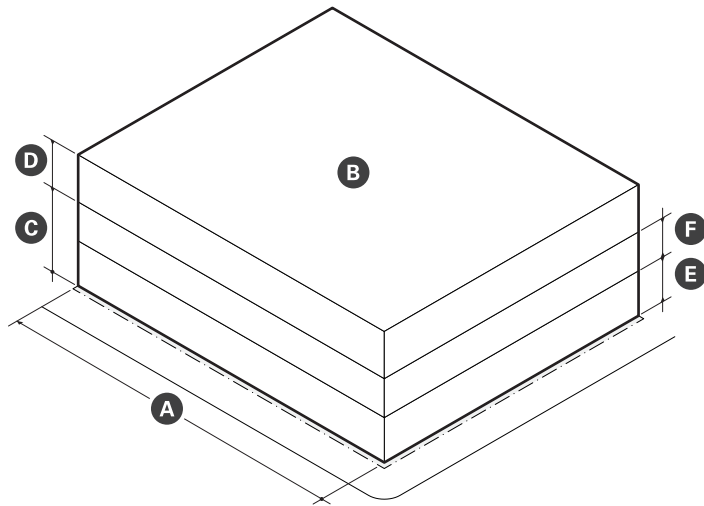

Main Massing	
A BUILDING WIDTH (max)	200 ft
FACADE Build Out, (min)	--
Primary Front	80%
Secondary Front	65%
B FLOOR PLATE (max)	15,000 sf
C GROUND STORY Height (min)	14 ft
D UPPER STORY Height (min)	10 ft
E NUMBER OF STORIES (min)	2 3
F BUILDING Height, Feet (max)	50 ft
Roof Type	Flat

d. Uses & Features

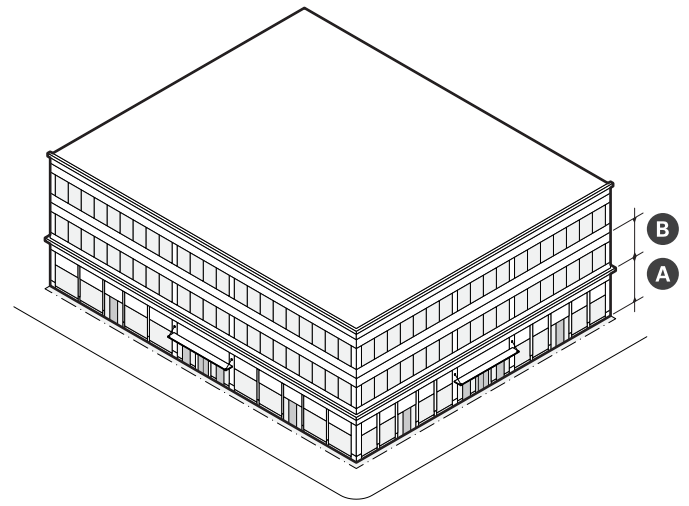

Facade Composition	
A GROUND STORY FENESTRATION (min)	70%
B UPPER STORY FENESTRATION (min/max)	20% 70%
BLANK WALL (max)	20 ft

Use & Occupancy	
GROUND STORY Entrance Spacing (max)	30 ft
Commercial Space Depth (min)	30 ft

4. MID-RISE DISTRICTS

Mid-Rise 3 (MR3)

4.1.9. Commercial Building (continued)

- e. DEVELOPMENT Benefits
 - i. DEVELOPMENT is subject to the provisions of Article 12: DEVELOPMENT Benefits of this Ordinance. Where the provisions of this section conflict with those of Article 12, the provisions of Article 12 apply.
 - ii. DEVELOPMENT of a general building must provide linkage payments as specified on Table 4.1.9.

Table 4.1.9 Linkage

Commercial GROSS FLOOR AREA	Affordable Housing Linkage	Employment Linkage
30,000 sf or less	None	None
Over 30,000 sf	\$10/sf	\$2.46/sf

10. Building Components

- a. Building components are ACCESSORY elements attached to the MAIN MASSING of a PRINCIPAL BUILDING.
- b. Building components are permitted by Site Plan Approval as specified on Table 4.1.10.
 - i. At least one (1) storefront is required for each GROUND STORY commercial space.
- c. Building components not identified on Table 4.1.10 are prohibited.
- d. Unless otherwise specified, building components may attach to other building components to create assemblies of components.

Table 4.1.10 Building Components

	Apartment BUILDING	General BUILDING	Commercial BUILDING
Awning	N	P	P
Entry Canopy	P	P	P
Lobby Entrance	P	P	P
Storefront	N	P	P
Stoop	P	N	N
Bay Window	P	P	P
Balcony	P	P	N
Arcade	N	N	N

P - Permitted N - Not Permitted

4. MID-RISE DISTRICTS

Mid-Rise 3 (MR3)

e. Awning

- i. An awning is a wall mounted frame covered with fabric or other material that provides shade and weather protection over a storefront or building entrance.

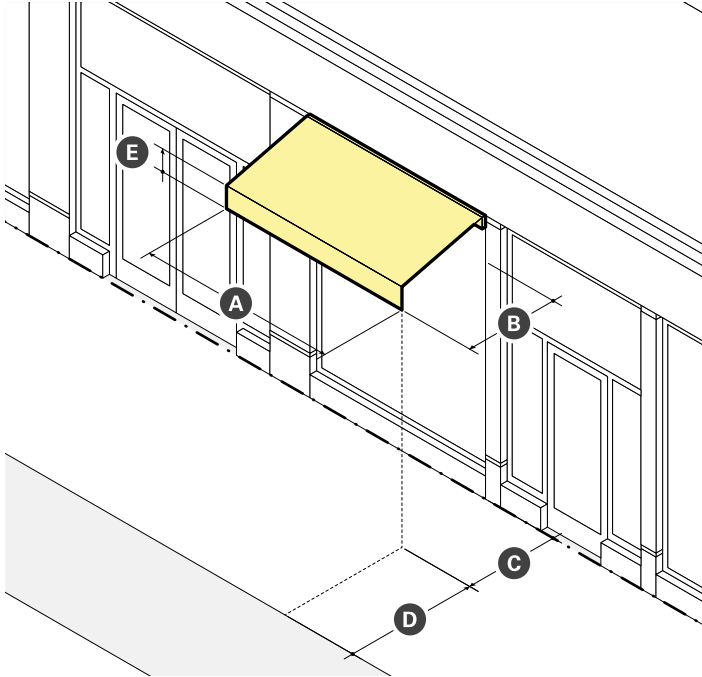

Dimensions	
A Width (min)	See ii Standards
B Projection (min)	3 ft
C CLEARANCE (min)	8 ft
Front SETBACK ENCROACHMENT (max)	100%
D SETBACK from Curb (min)	2 ft
E Valance Height (max)	12 in

- ii. Standards
 - a). Awnings must be securely attached to and supported by the building and must fit the windows or doors the awning is attached to.
 - b). An awning must be made of durable, weather-resistant material that is water repellent.
 - c). Internally illuminated or back-lit awnings are prohibited.
 - d). An awning that projects over the sidewalk of a public THOROUGHFARE requires compliance with all City Ordinances.

f. Entry Canopy

- i. An entry canopy is a wall-mounted structure that provides shade and weather protection over a storefront or building entrance.

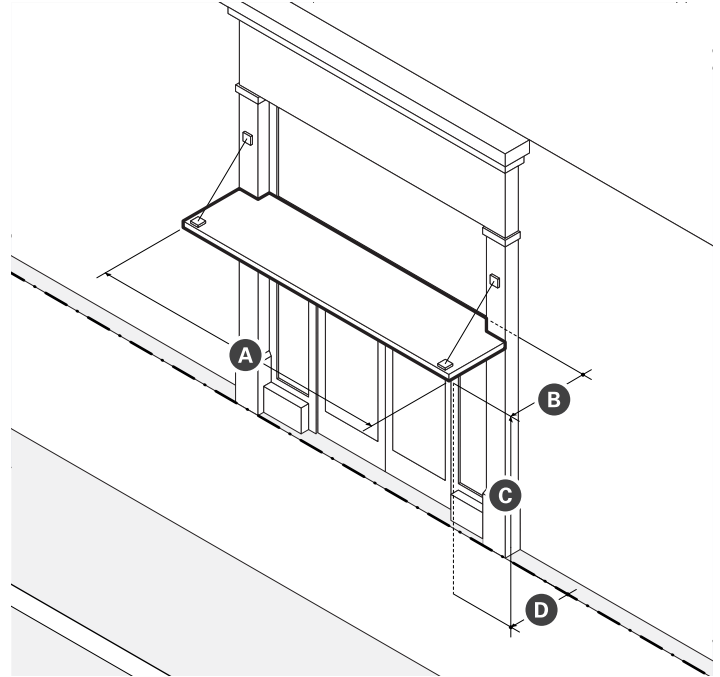

Dimensions	
A Width (min)	See ii Standards
B Projection (min)	3 ft
C CLEARANCE (min)	8 ft
D Front SETBACK ENCROACHMENT (max)	100%
SETBACK from Curb (min)	2 ft

- ii. Standards
 - a). Entry canopies must be visually supported by brackets, cables, or rods.
 - b). The width of an entry canopy must be equal to or greater than the width of the doorway surround or exterior casing it is mounted over.

g. Lobby Entrance

- i. A lobby entrance is a non-load bearing assembly of entry doors and windows providing access and light to the lobby of a building.

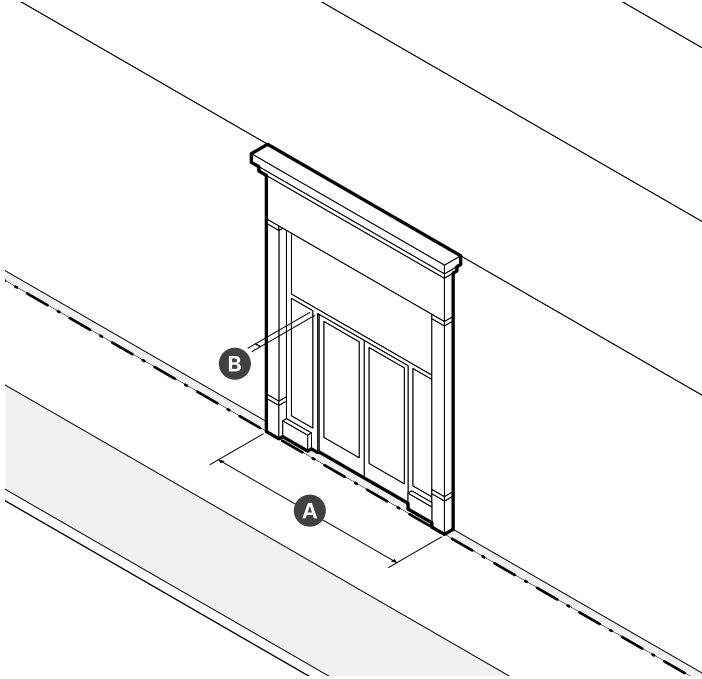

Dimensions		
A Width (min/max)	15 ft	30 ft
B Height (min)	80% of GROUND STORY Height	
Recessed Entrance Width (max)	15 ft	
Recessed Entrance Depth (max)	5 ft	

- ii. Standards
 - a). When a lobby entrance is set back from the FRONT LOT LINE, the FRONTAGE AREA must be paved.

h. Storefront

- i. A storefront is a non-load bearing assembly of commercial entry doors and windows providing ACCESS and light to a commercial space and a place to display goods, services, and SIGNS.

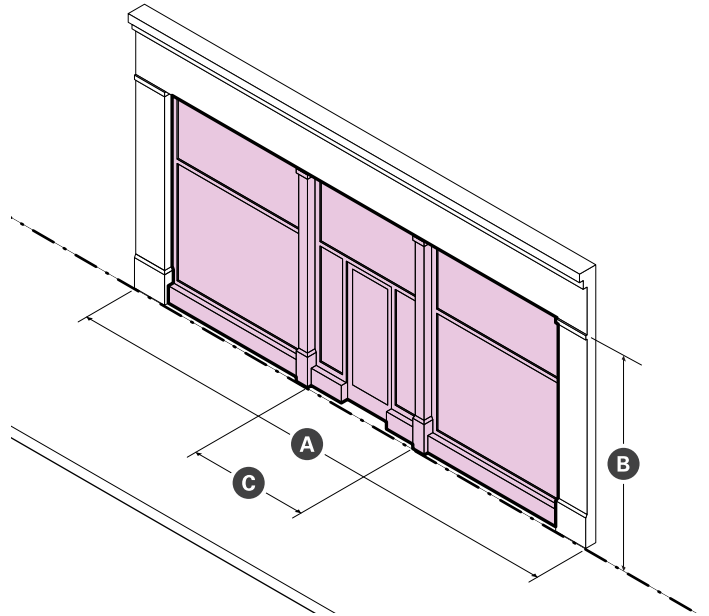

Dimensions		
A Width (min/max)	15 ft	30 ft
B Height (min)	80% of GROUND STORY Height	
Display Window Height (min)	8 ft	
Recessed Entrance Width (max)	15 ft	
Recessed Entrance Depth (max)	5 ft	

- ii. Standards
 - a). An unobstructed view of the interior space or a lighted and maintained merchandise display(s) must be provided for a depth of at least four (4) feet behind storefront display windows.
 - b). When storefronts are set back from the FRONT LOT LINE, the FRONTAGE AREA must be paved.
 - c). When present, awnings and canopies must be mounted between columns, PILASTERS, OR PIERS; above doorways and display windows; and below the SIGN BAND.
 - d). Exterior security grilles, gates, and roll-down security doors and windows are prohibited.

4. MID-RISE DISTRICTS

Mid-Rise 3 (MR3)

i. Stoop

- i. A stoop is a set of stairs with a landing leading to the entrance of a building.

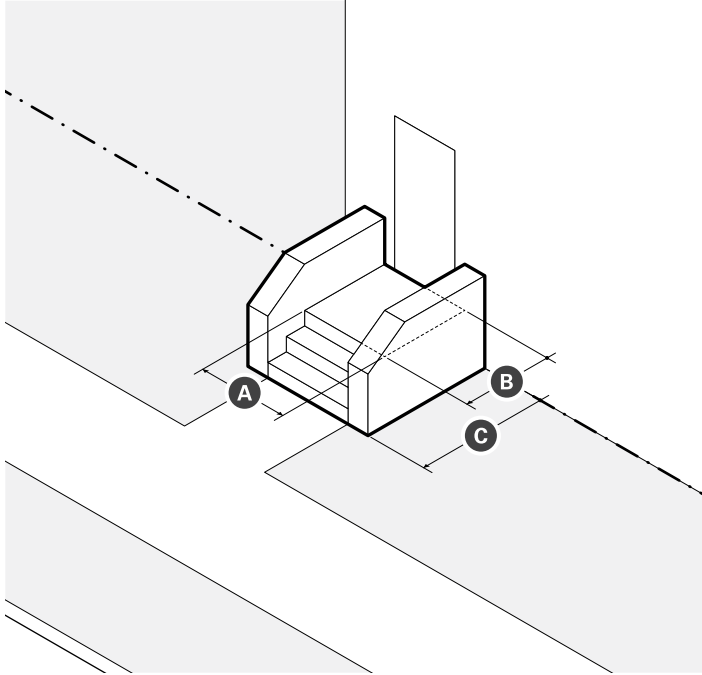

Dimensions	
A Landing Width (min)	4 ft
B Landing Depth (min)	4 ft
C Front SETBACK ENCROACHMENT (max)	100%

- ii. Standards
 - a). Paving, excluding driveways, must match the ABUTTING sidewalk unless paved with pervious, porous, or permeable materials.
 - b). Stairs may be recessed into the building FACADE when the building is set back four (4) feet or less.
 - c). Stairs are not permitted to ENCROACH onto any ABUTTING sidewalk.
 - d). Stairs may be built perpendicular or parallel to the building FACADE, but must lead directly to ground level or an ABUTTING sidewalk.

j. Bay Window

- i. A bay window is an assembly of windows projecting from a building to provide additional HABITABLE space, increased light, multi-directional views, and ARTICULATION to an exterior wall.

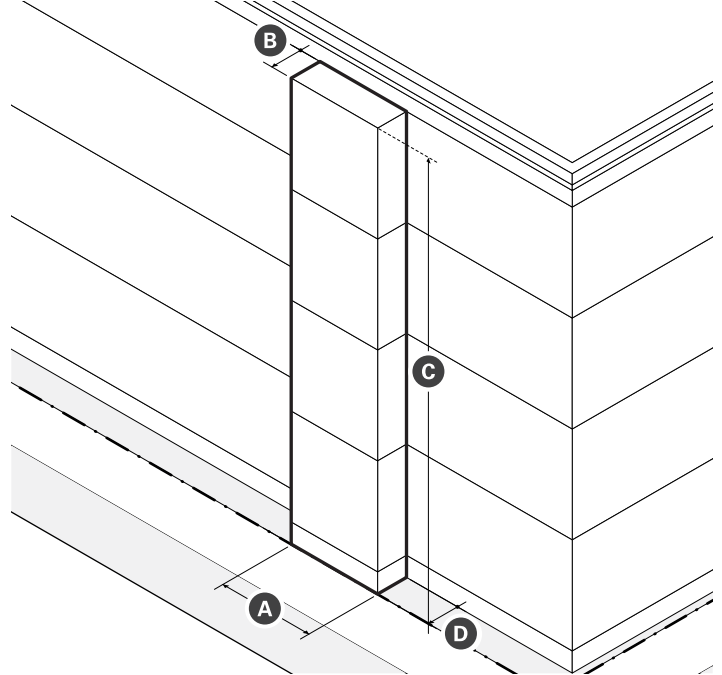

Dimensions	
A Width (max)	16 ft
B Projection (max)	3 ft
C Height (max)	Height of BUILDING in Stories
D Front SETBACK ENCROACHMENT (max)	3 ft
FENESTRATION (min)	60%

- ii. Standards
 - a). Bay windows, including box and bow windows, must include at least three (3) windows.
 - b). The cumulative width of multiple bays may equal up to fifty percent (50%) of the width of the exterior wall from which the bays project.
 - c). Bays projecting over the sidewalk of a public THOROUGHFARE must have at least two (2) stories of CLEARANCE and be compliant with all City Ordinances.

k. Balcony

- i. A balcony is a platform with a railing that provides outdoor AMENITY SPACE.

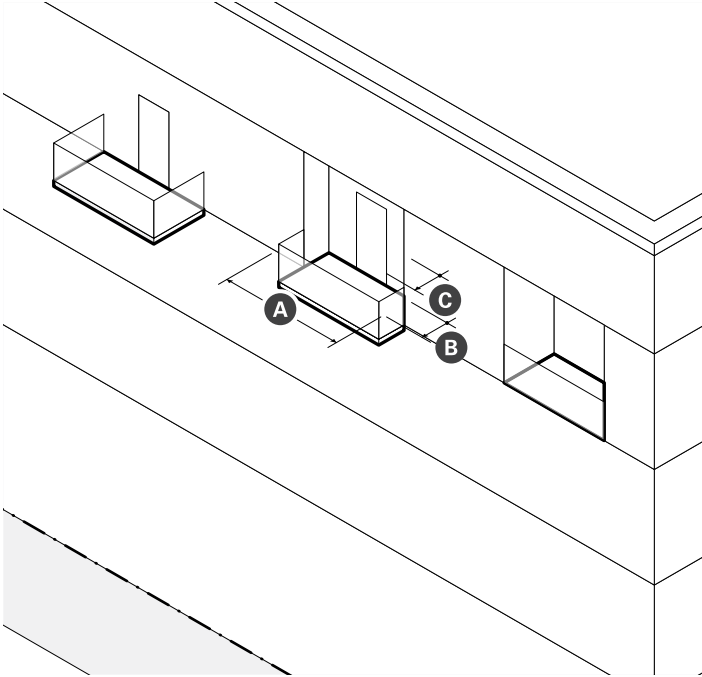

Dimensions	
A Width (min)	5 ft
B Depth (max)	5 ft
D Area (min)	50 ft
CLEARANCE (min)	10 ft
Permitted Front SETBACK ENCROACHMENT (max)	6 ft

- ii. Standards
 - a). Balconies may be recessed, projecting, a combination of the two, or terraced as part of the roof of a portico, porch, or bay.
 - b). A balcony that projects over the sidewalk of a public THOROUGHFARE requires compliance with all City Ordinances.
 - c). The guard rail of any balcony oriented toward a FRONT LOT LINE must permit visual supervision of the PUBLIC REALM through the posts and rails.
 - d). The guard rail of any balcony oriented toward a side OF REAR LOT LINE ABUTTING the NR district must include sight-obscuring visual screening so that it is at least fifty percent (50%) opaque.

l. Arcade

- i. An arcade is a pedestrian walkway covered by the upper floors of a building. The GROUND STORY FACADE is SETBACK and upper floors are supported by a colonnade or supports.

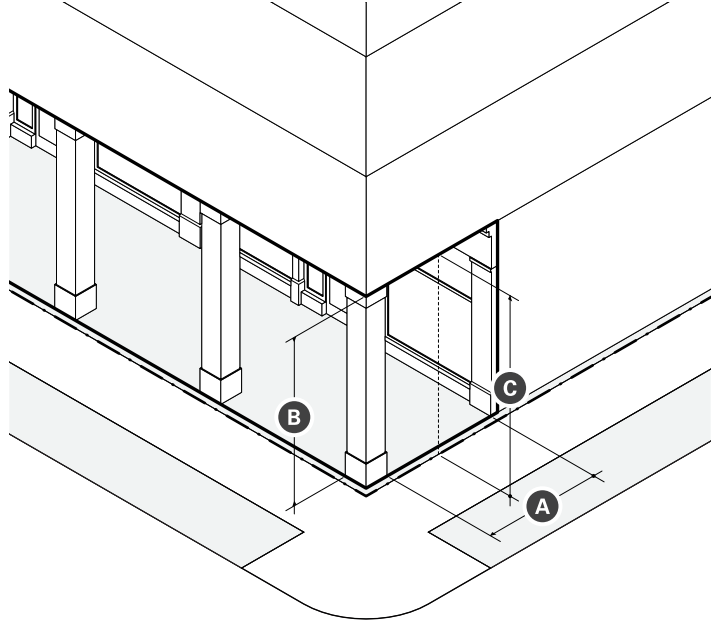

Dimensions		
A Depth (min/max)	10 ft	15 ft
B Height (max)	1 STORY	
C CLEARANCE (min/max)	14 ft	24 ft

- ii. Standards
 - a). Arcades must extend the entire width of a building and must have a consistent depth.
 - b). Support columns or PIERS may be spaced no farther apart than they are tall.
 - c). Arcades are considered part of the building for the purpose of measuring FACADE build out.
 - d). Arcades may be combined only with storefront and lobby entrance frontages.
 - e). The finished ceiling of an arcade interior may be arched or flat, but must have a greater CLEARANCE than the openings between columns OR PIERS.

4. MID-RISE DISTRICTS

Mid-Rise 3 (MR3)

11. Facade Design

- a. FACADES must provide solid material framing each storefront and lobby entrance as follows:
 - i. PILASTERS or columns supporting a horizontal lintel and CORNICE;
 - ii. a spandrel positioned between PILASTERS or columns that extend from upper stories of the building to the ground; or
 - iii. flat wall above and to either side of a void or punched opening.
- b. Storefronts and lobby entrances must be set within the resulting frame provided for each by the FACADE.
- c. Materials framing each storefront or lobby entrance may be integrated into the design of the FACADE or customized for individual storefronts and lobby entrances.
- d. Mechanical louvers necessary for venting purposes are not permitted in the required frame, but may be incorporated into any storefront or lobby entrance system.
- e. FACADES must differentiate the GROUND STORY of the building from the upper stories through horizontal ARTICULATION, a change in material, or a change in window size or pattern to create a distinct base to the building FACADE. The entire height of the GROUND STORY must be included in the FACADE base.
- f. For buildings with more than one FACADE, the design of the base must align horizontally at the corner.
- g. FACADES must provide surface relief from the average plane of the FACADE by at least four (4) inches, through

the USE of architectural elements such as bay windows, columns, CORNER BOARDS, CORNICES, door and window surrounds, moldings, PIERS, PILASTERS, recessed storefronts or lobby entrances, seat walls, sills, wall thickness, and recessed or projecting windows.

- h. The FACADE of any building greater than one hundred (100) feet in width must be designed as two (2) or more separate and distinct facades of differing architectural design so that the building appears to be multiple buildings. The facade designs must include a change in CORNICE, roof eave, or parapet design from one another.

12. Architectural Design Guidelines

- a. FACADES should be visually divided into a series of ARCHITECTURAL BAYS that are derived, in general, from the building's structural bay spacing.
- b. PIERS, PILASTERS, or other features defining each ARCHITECTURAL BAY should either extend all the way to the ground or terminate at any horizontal ARTICULATION defining the base of the building.
- c. ARCHITECTURAL BAYS should align, in general, with individual or groups of storefronts and lobby entrances.
- d. PIERS, PILASTERS, or other features defining each ARCHITECTURAL BAY should always project forward and be uninterrupted by any horizontal articulation, excluding any horizontal ARTICULATION USED to differentiate the base of the building.
- e. Vents, exhausts, and other utility features on building FACADES should be architecturally integrated into

Figure 4.1.11 (a) Storefront & Lobby Entrance Framing

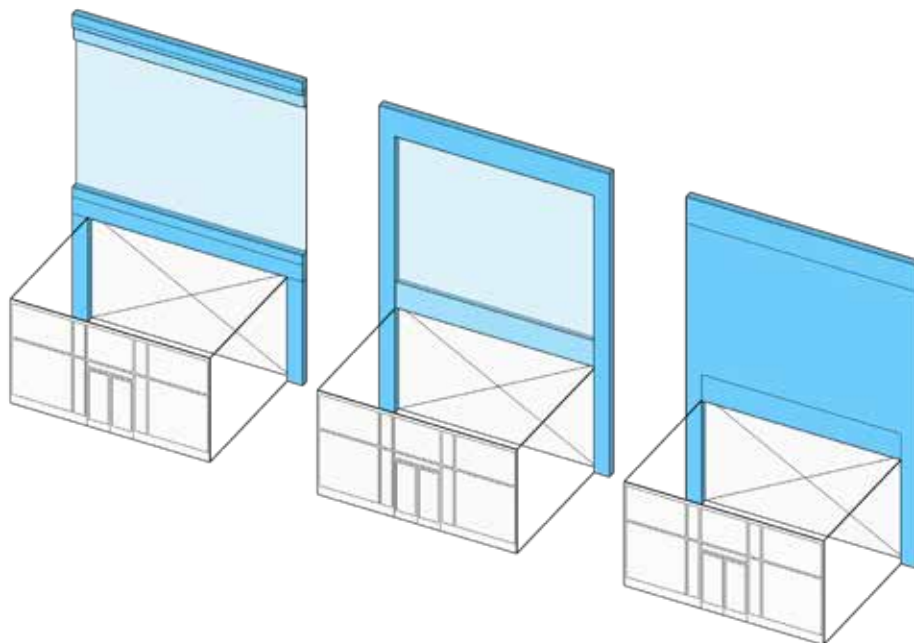

the design of the building and should be located to minimize adverse effects on pedestrian comfort along sidewalks and within OPEN SPACES.

- f. Buildings at TERMINATED VISTAS should be ARTICULATED with design features that function as focal points.
- g. FENESTRATION glazing should be inset from the plane of exterior wall surfaces.
- h. RIBBON WINDOWS should be avoided.
- i. Monotonous and repetitive storefront or lobby systems, awnings, canopies, SIGN types, colors, or designs should be avoided.
- j. Storefronts and lobby entrances should include awnings or canopies to provide weather protection for pedestrians and reduce glare for storefront display areas. Awnings should be open-ended and operable.
- k. Lobby entrances for UPPER STORY USES should be optimally located, well defined, clearly visible, and separate from the entrance for other GROUND STORY USES.
- l. Lobbies should be limited in both width and total area to preserve floor space and frontage for other GROUND STORY USES. Buildings should USE any combination of FACADE ARTICULATION, a double-height ceiling, a distinctive doorway, a change in wall material, a change in paving material within the FRONTAGE AREA, or some other architectural element(s) to make lobbies visual and materially distinctive.
- m. The selection of materials, FENESTRATION, and ornamentation should result in a consistent and harmonious composition that appears as a unified whole rather than a collection of unrelated parts, no

matter the style.

- n. The type and color of materials should be kept to a minimum, preferably three (3) or fewer.
- o. Two (2) or more wall materials should be combined only one above the other, except for bay windows.
- p. Wall materials appearing heavier in weight should be used below wall materials appearing lighter in weight (wood and metal above brick, and all three above stone)
- q. Horizontal or vertical board siding or shingles, regardless of material, should be avoided.
- r. Architectural details and finish materials for the base of a building should be constructed of architectural concrete or pre-cast cementitious panels, natural or cast stone, heavy gauge metal panels, glazed or unglazed architectural terracotta, or brick.
- s. Exterior Insulation and Finish Systems (EIFS) should be avoided.

Figure 4.1.11 (b) Appearance of Two Buildings



4. MID-RISE DISTRICTS

Mid-Rise 3 (MR3)

13. Use Provisions

- a. General
 - i. The USE of real property is subject to the provisions of Article 9: USE Provisions of this Ordinance. Where the provisions of this section conflict with those of Article 9, the provisions of Article 9 apply.
 - ii. USE categories are permitted as specified on Table 4.1.13. USE categories that are not identified on Table 4.1.13 are prohibited.
 - iii. All USES must comply with any USE-specific standards applicable for each USE in §9.2 USE Definitions & Limitations.
 - iv. USES permitted by Special Permit require additional DEVELOPMENT review in accordance with §15.2.1 Special Permits.
- b. USE Limitations
 - i. The USE of any GROUND STORY commercial space fronting a PEDESTRIAN STREET, excluding lobbies for UPPER STORY USES, is limited to the following PRINCIPAL USE categories:
 - a). Arts & Creative Enterprise
 - b). Food & Beverage Service
 - c). Retail Sales
 - d). Civic & Institutional
- c. Increases in Density
 - i. Existing structures may not be altered to conflict with number of DWELLING UNITS permitted for each BUILDING TYPE.

Table 4.1.13 Permitted Uses

Use Category Specific Use	MR3
Arts & Creative Enterprise	
Artisinal Production	P
Arts Exhibition	P
Arts Sales & Services	P
Co-working	P
Design Services	P
Shared Workspaces & Arts Education	P
Cannabis Establishment	
Cannabis Cultivation	P
Cannabis Retail Sales	SP
Cannabis Research & Development	P
Cannabis Testing Laboratory	P
Civic & Institutional	
Community Center	P
Hospital	SP
Library	P
Minor Utility Facility	SP
Museum	P
Private Non-Profit Club or Lodge	SP
Public Service	P
Religious & Educational Uses Protected by M.G.L 40A. Sec 3	P

P - Permitted SP - Special Permit Required N - Not Permitted

Table 4.1.13 Permitted Uses (continued)

Use Category Specific Use	MR3
Commercial Services	
Animal Services (as noted below)	--
Commercial Kennel	SP
Pet Grooming	P
Pet Daycare & Training	SP
Veterinarian	SP
Assembly or Entertainment	SP
Banking & Financial Services (except as follows)	P
Personal Credit	SP
Broadcast and/or Recording Studio	P
Building & Home Repair Services	SP
Business Support Services	P
Caterer/Wholesale Food Production	SP
Day Care Service (as noted below)	--
Adult Day Care Center	P
Child Day Care Center	P
Educational Services	P
Maintenance & Repair of Consumer Goods	P
Personal Services (except as follows)	P
Body-Art Services	SP
Fitness Services	P
Funeral Services	SP
Health Care Services	SP
Formula Personal Services	SP
Recreation Services	SP
Vehicle Parking, Commercial (except as follows)	--
Bike Share Parking	P
Car Share Parking (3 or fewer spaces)	P
Car Share Parking (4 or more spaces)	P
Commercial Parking	P
Food and Beverage Service	
Bar/Restaurant/Tavern	P
Bakery/Café/Coffee Shop	P
Formula Food & Beverage Service	SP

P - Permitted SP - Special Permit Required N - Not Permitted

Table 4.1.13 Permitted Uses (continued)

Use Category Specific Use	MR3
Lodging	
Bed & Breakfast	SP
Hotel or Hostel	SP
Office	
General Office	P
Research and Development and/or Laboratory	P
Residential	
Household Living	SP
Group Living (except as follows)	SP
Community or Group Residence	P
Dormitory, Fraternity or Sorority	SP
Homeless Shelter	SP
Nursing Home/Assisted Living Facility	SP
Rooming House	SP
Retail Sales	
Building/Home Supplies & Equipment	SP
Consumer Goods (except as follows)	P
Alcohol Sales	SP
Firearms Sales	N
Pet Store	SP
Formula Retail	SP
Fresh Food Market or Grocery Store	P
Farm/Vendor Market	P
Urban Agriculture	
Farming (as noted below)	--
Commercial Farming	P
Community Farming	P
Community Gardening	P

P - Permitted SP - Special Permit Required N - Not Permitted

4. MID-RISE DISTRICTS

Mid-Rise 3 (MR3)

Table 4.1.13 Permitted Uses (continued)

Use Category Specific Use	MR3
Accessory Uses	
Home Occupations (as noted below)	--
Creative Studio	N
Hobby Kennel	N
Home-Based Business	N
Home Day Care	N
Home Office	P
Urban Agriculture (as noted below)	--
Apiculture	P
Aviculture	P
Commercial Farming	P
Residential Gardening	P
Vehicle Parking, Accessory (except as follows)	P
Home Business Vehicle Parking	N

P - Permitted SP - Special Permit Required N - Not Permitted

14. Development Standards

- a. General
 - i. DEVELOPMENT is subject to the provisions of Article 10: DEVELOPMENT Standards of this Ordinance. Where the provisions of this section conflict with those of Article 10, the provisions of Article 10 apply.
- b. SIGNS
 - i. A SIGN, individual numerals or letters, or a nonelectrical nameplate identifying the property address is required for all real property as follows:
 - a). Each GROUND STORY non-residential USE must identify the STREET address either on the PRINCIPAL ENTRANCE door or above or beside the PRINCIPAL ENTRANCE of the USE.
 - b). All residential BUILDING TYPES must identify the STREET address either on the PRINCIPAL ENTRANCE door, above or beside the PRINCIPAL ENTRANCE, or on a mailbox.
 - ii. Address SIGNS must be made easily visible through the USE of colors or materials that contrast with the background material they are attached to and must be conspicuously located to provide visibility from the THOROUGHFARE that the building faces.
 - iii. Address SIGNS must be twelve (12) inches in height or less and may include the name of the occupant.

15. Parking & Mobility

- a. General
 - i. DEVELOPMENT is subject to the provisions of Article 11: Parking & Mobility of this Ordinance. Where the provisions of this section conflict with those of Article 11, the provisions of Article 11 apply.
 - ii. Vehicular parking must be provided as specified on Table 4.1 (d), except as follows:
 - a). Non-residential USES with five thousand (5,000) square feet or less of GROSS LEASABLE FLOOR AREA are exempt from any minimum requirements of Table 4.1. (d).
 - b). Any CHANGE IN USE within a non-residential structure constructed before the effective date of this Ordinance, provided that the change is to a permitted USE, is exempt from any minimum requirements of Table 4.1 (d).
 - iii. There are no parking requirements for ACCESSORY USES.
 - iv. Motor vehicle parking spaces may be shared between USES on the same LOT and buildings on the same BLOCK in accordance with §11.3 SHARED PARKING.
- b. Type
 - i. Motor vehicle parking may be provided as SURFACE PARKING, above ground STRUCTURED PARKING, and underground STRUCTURED PARKING.
- c. Driveways
 - i. New driveways require a permit from the City Engineer.
 - ii. Driveways must be compliant with all City Ordinances and constructed in accordance with all standards established by relevant City Departments.
 - iii. Driveways are not permitted in the FRONTAGE AREA between a building and the FRONT LOT LINE.
 - iv. Driveways may be no wider than twelve (12) feet in the FRONTAGE AREA OF A LOT.
 - v. Driveways may provide ACCESS in whole or in part on or across an ABUTTING LOT(s), provided that an ACCESS EASEMENT exists between all PROPERTY OWNERS.
- d. Parking Design
 - i. The design of all parking is subject to §11.1 Bicycle Parking and §11.2 Motor Vehicle Parking of this Ordinance.
- e. Parking Location
 - i. Required vehicular parking, excluding any required handicapped parking, may be provided on a contiguous LOT under the same ownership as the LOT that the parking will serve as follows:
 - a). Pedestrian ACCESS to off-SITE vehicular parking must be via a paved sidewalk or walkway.
 - b). A lease, recorded covenant, or other comparable legal instrument guaranteeing long

- ii. term USE of the SITE must be provided to the review board or BUILDING OFFICIAL and executed and filed with the Registry of Deeds.
- ii. For real property located in more than one municipality, motor vehicle parking need not be located within the City of Somerville.
- f. Unbundled Parking
 - i. Motor vehicle parking spaces must be rented or leased as an option rather than a requirement of the rental, lease, or purchase of a DWELLING UNIT or non-residential floor space.
 - ii. Bicycle parking must be provided at no cost or fee to customers, visitors, employees, tenants, and residents.
- g. Parking Relief
 - i. Relief from the parking standards of Table 4.1 (d) requires a special permit.
 - a). In addition to the review criteria for all Special Permits specified in §15.2.1.e. Review Criteria, the review board shall make findings considering the following in its discretion to approve or deny a special permit authorizing relief from the parking standards of Table 4.1 (d):
 - i). The supply and demand of on-STREET parking in the neighborhood, as determined through a parking study.
 - ii). MOBILITY MANAGEMENT programs and services provided by the APPLICANT to reduce the demand for parking.
 - iii). That parking provided in excess of any maximum permitted does not result in the increase in impervious LOT AREA.

16. Public Realm

- a. Sidewalks
 - i. When DEVELOPMENT OCCURS on any LOT ABUTTING a sidewalk that is less than twelve (12) feet in total width, the building must be set-back an additional distance to accommodate expansion of the ABUTTING sidewalk to a width of at least twelve (12) feet. The minimum and maximum front SETBACKS for each BUILDING TYPE are increased accordingly.
- b. Sidewalk CURB CUTS
 - i. A CURB CUT requires a permit from the City Engineer and must be compliant with all City Ordinances.
 - ii. Unless otherwise specified, the City Engineer may not permit more than one (1) CURB CUT per FRONT LOT LINE of a LOT.
 - iii. CURB CUTS are prohibited along all THOROUGHFARES designated as a PEDESTRIAN STREET.
 - iv. CURB CUTS must be located to minimize conflicts with pedestrians and bicyclists and must have a clear distance from fire hydrants, STREET TREES, utility

4. MID-RISE DISTRICTS

Mid-Rise 3 (MR3)

Table 4.1.15 Vehicular Parking

Use Category Specific Use	BICYCLE		MOTOR VEHICLE	
	Short-Term (min)	Long-Term (min)	Within a TRANSIT AREA ¹ (max)	Outside of a TRANSIT AREA ¹ (min)
Arts & Creative Enterprise				
All Permitted Uses	1 / 10,000 sf	1 / 3,000 sf	1 / 800 sf	1 / 1,000 sf
Cannabis Establishment				
Cannabis Retail Sales	1 / 2,500 sf	1 / 10,000 sf	1 / 1,500 sf	1 / 750 sf
Cannabis Research & Development	1 / 20,000 sf	1 / 5,000 sf	1 / 1,000 sf	1 / 1,000 sf
Cannabis Testing Laboratory	1 / 20,000 sf	1 / 5,000 sf	1 / 1,000 sf	1 / 1,000 sf
Civic & Institutional				
Community Center	1 / 10,000 sf	4 / 10,000 sf	1 / 1,800 sf	1 / 600 sf
Educational Facility	1.0 / classroom	4.0 / classroom	1.5 / classroom	3.0 / classroom
Hospital	10 per entrance	1 / 5,000 sf	1 / 200 sf	1 / 1,000 sf
Library	1 / 3,000 sf	1 / 5,000 sf	1 / 800 sf	1 / 500 sf
Minor Utility Facility	n/a	n/a	n/a	n/a
Museum	1 / 2,000 sf	1 / 10,000 sf	1 / 800 sf	1 / 500 sf
Private Non-Profit Club or Lodge	1 / 2,000 sf	1 / 10,000 sf	1 / 200 sf	1 / 1,000 sf
Commercial Services				
Animal Services (as noted below)	–	–	–	–
Commercial Kennel	1 / 2,500 sf	1 / 10,000 sf	1 / 500 sf	1 / 500 sf
Pet Grooming	1 / 2,500 sf	none	1 / 500 sf	1 / 500 sf
Pet Day Care or Training	1 / 2,500 sf	none	1 / 500 sf	1 / 500 sf
Veterinarian	1 / 2,500 sf	1 / 5,000 sf	1 / 500 sf	1 / 500 sf
Assembly or Entertainment	1 / 40 seats	1 / 10,000 sf	1 / 6 seats	1 / 6 seats
Banking & Financial Services (except as noted below)	1 / 2,000 sf	1 / 10,000 sf	1 / 450 sf	1 / 400 sf
Broadcast and/or Recording Studio	1 / 2,500 sf	1 / 10,000 sf	1 / 800 sf	1 / 600 sf
Building & Home Repair Services	1 / 2,500 sf	1 / 10,000 sf	1 / 1,000 sf	1 / 2,000 sf
Business Support Services	1 / 2,500 sf	1 / 10,000 sf	1 / 900 sf	1 / 600 sf
Caterer/Wholesale Food Production	1 / 2,500 sf	1 / 10,000 sf	1 / 800 sf	1 / 1,000 sf
Day Care Service	2	1 / 10,000 sf	1 / 900 sf	1 / 600 sf
Maintenance & Repair of Consumer Goods	1 / 2,500 sf	1 / 10,000 sf	1 / 750 sf	1 / 1,000 sf
Personal Services (except as noted below)	1 / 2,500 sf	1 / 10,000 sf	1 / 750 sf	1 / 1,000 sf
Health Care Services	1 / 2,000 sf	1 / 10,000 sf	1 / 500 sf	1 / 300 sf
Recreation Services	1 / 2,500 sf	1 / 10,000 sf		

sf - Gross Leasable Square Footage DU - Dwelling Unit RU - Rooming Unit

¹ See the Transit Area Map

Table 4.1.15 Vehicular Parking (continued)

*See Transit Orientation Map for distance to a TRANSIT STATION

Use Category Specific Use	BICYCLE		MOTOR VEHICLE	
	Short-Term (min)	Long-Term (min)	Within a TRANSIT AREA ¹ (max)	Outside of a TRANSIT AREA ¹ (min)
Food and Beverage Service				
All Permitted Uses	1 / 1,000 sf	1 / 5,000 sf	1 / 300 sf	1 / 500 sf
Lodging				
Bed & Breakfast	n/a	2	1 / DU + 1 / 4 guest rooms	1 / DU + 1 / 4 guest rooms
Hotel or Hostel	1 / 20 rooms	1 / 10 rooms	1 / 2 rooms	1 / 2 rooms
Office				
Co-Working	1 / 20,000 sf	1 / 3,000 sf	1 / 1,200 sf	1 / 800 sf
General Office	1 / 20,000 sf	1 / 3,000 sf	1 / 900 sf	1 / 650 sf
Research and Development and/or Laboratory	1 / 20,000 sf	1 / 5,000 sf	1 / 1,000 sf	1 / 1,000 sf
Residential				
Household Living	0.1 / DU	1.0 / DU	1.0 / DU	1.0 / DU
Group Living (except as follows)	0.05 / RU	0.5 / RU	–	–
Community or Group Residence	–	–	–	–
Dormitory, Fraternity or Sorority	0.1 / bed	0.5 / bed	.05 / bed	1.0 / 4 beds
Homeless Shelter	–	–	4.0	4.0
Nursing Home/Assisted Living Facility	–	–	1 / 6 beds	1 / 6 beds
Single Room Occupancy Housing	–	–	1 / 6 beds	1 / 4 beds
Retail Sales				
Building/Home Supplies & Equipment	1 / 2,500 sf	1 / 10,000 sf	1 / 1,000 sf	1 / 1,000 sf
Consumer Goods (except as follows)	1 / 2,500 sf	1 / 10,000 sf	1 / 1,500 sf	1 / 750 sf
Formula Retail	1 / 2,500 sf	1 / 10,000 sf	1 / 1,500 sf	1 / 750 sf
Fresh Food Market or Grocery Store	1 / 1,000 sf	1 / 10,000 sf	1 / 500 sf	1 / 1,500 sf
Farm/Vendor Market	n/a	n/a	n/a	1 / 1,500 sf

sf - Gross Leasable Square Footage DU - Dwelling Unit RU - Rooming Unit

¹ See the Transit Area Map

4. MID-RISE DISTRICTS

Mid-Rise 3 (MR3)

poles, and other furnishings as deemed necessary by the City Engineer.

- a). CURB CUTS for commercial or high-volume driveways should be at least one-hundred (100) feet from an UNSIGNALIZED or SIGNALIZED intersection.
- b). CURB CUTS for residential driveways should be at least twenty (20) feet from an UNSIGNALIZED intersection and at least forty (40) feet from a SIGNALIZED intersection.
- v. The interior width of a CURB CUT (between curb stones) may be no wider than the driveway, vehicular entrance, or loading facility it serves.
- vi. A DRIVEWAY APRON may be installed only within the furnishing zone of a sidewalk and must be constructed in accordance with all standards established by relevant City Departments.
- vii. The grade, cross slope, and clear width of the walkway of a sidewalk must be maintained between the DRIVEWAY APRON and the ABUTTING driveway. The appearance of the walkway (ie. scoring pattern or paving material) must indicate that, although a vehicle may cross, the area traversed by a vehicle remains part of the sidewalk.

Figure 4.1.17 Sidewalk Curb Cuts

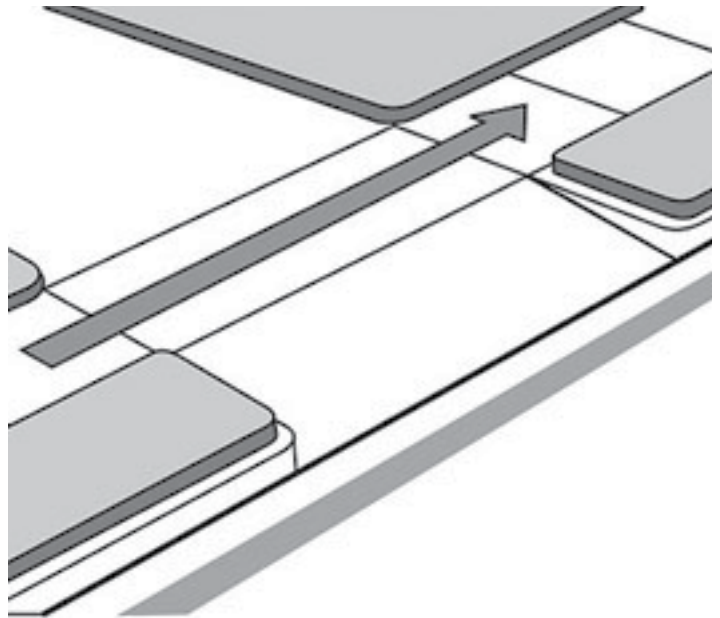

4.2 MID-RISE 4 (MR4)

1. Character Description

The Mid-Rise 4 district is characterized by a variety of moderate FLOOR PLATE buildings up to four (4) stories in height. Buildings are set close to the sidewalk to create a defined STREET wall that supports pedestrian activity

and a sense of place. The district is primarily commercial, with GROUND STORY USES that typically address the needs of residents and employees in the immediate neighborhood.



4. MID-RISE DISTRICTS

Mid-Rise 4 (MR4)

2. Intent

- a. To implement the objectives of the COMPREHENSIVE PLAN of the City of Somerville.
- b. To create, maintain, and enhance areas appropriate for smaller scale, multi-USE and mixed-USE buildings and neighborhood serving USES.

3. Purpose

- a. To permit the DEVELOPMENT of multi-unit and mixed-USE buildings that do not exceed four (4) stories in height.
- b. To provide quality commercial spaces and permit small-scale, neighborhood serving commercial USES.
- c. To create DWELLING UNIT types, sizes, and BEDROOM counts ideal for larger households in apartment buildings.
- d. To create DWELLING UNIT types, sizes, and BEDROOM counts ideal for smaller households in general buildings.
- e. To permit increased residential density for buildings that are sustainable or that provide 100% AFFORDABLE HOUSING.
- f. To permit increased residential density for buildings that meet the definition of a NET ZERO BUILDING or 100% AFFORDABLE HOUSING.

4. Applicability

- a. The section is applicable to all real property within the Mid-Rise 4 district as shown on the maps of the Official Zoning Atlas of the City of Somerville.

5. Development Review

- a. DEVELOPMENT review is subject to the provisions of Article 15: Administration of this Ordinance.
- b. All DEVELOPMENT, excluding NORMAL MAINTENANCE, requires the submittal of a development review application to the BUILDING OFFICIAL and the issuance of a Certificate of Zoning Compliance prior to the issuance of a Building Permit or Certificate of Occupancy.
- c. Proposed DEVELOPMENT may or may not necessitate the need for SUBDIVISION Plan Approval, Site Plan Approval, a Special Permit, or a Hardship Variance based on the nature of the proposal. In such cases, additional DEVELOPMENT review is required in accordance with Article 15: Administration.
 - i. The Planning Board is the decision making authority for all DEVELOPMENT that requires Site Plan Approval or a Special Permit.
 - ii. The Zoning Board of Appeals is the Review Board for all HardSHIP Variances.
- d. Upon verification that no additional DEVELOPMENT review is necessary, or completion of the required DEVELOPMENT review, the BUILDING OFFICIAL shall issue a Zoning Compliance Certificate to certify compliance with the provisions and procedures of this Ordinance.

6. Building Types

- a. One (1) PRINCIPAL BUILDING TYPE is permitted on each LOT.
- b. The following BUILDING TYPES are permitted by Site Plan Approval in the Mid-Rise 4 district:
 - i. Apartment Building
 - ii. General Building
 - iii. Commercial Building
- c. Apartment Buildings are prohibited on any LOT fronting a PEDESTRIAN STREET.
- d. ACCESSORY structures are regulated according to Article 10: DEVELOPMENT Standards of this Ordinance.

4.2.7 Apartment Building

A moderate FLOOR PLATE, multi-STORY, PRINCIPAL BUILDING TYPE purpose built for OCCUPATION by residential USES on all stories.

The following images are examples of the apartment BUILDING TYPE and are intended only for illustrative purposes.



[Version Notes:](#)
§4.2.3.c deleted from previous version

4. MID-RISE DISTRICTS

Mid-Rise 4 (MR4)

4.2.7. Apartment Building (continued)

a. Lot Standards

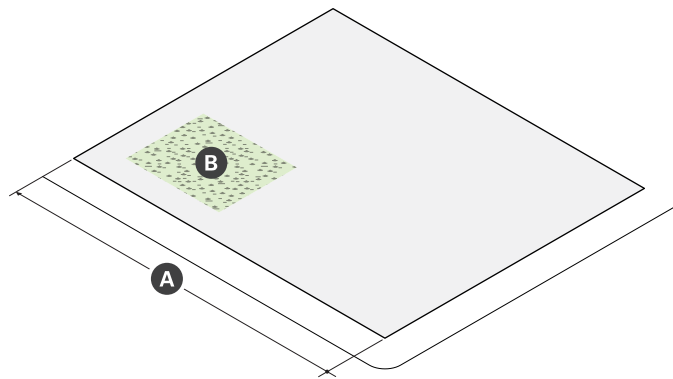

Lot Dimensions	
A LOT WIDTH (min)	30 ft

Lot Development	
LOT Coverage (max)	90%
GREEN SCORE	--
Minimum	0.25
Ideal	0.30
B OPEN SPACE (min)	15%

b. BUILDING Placement

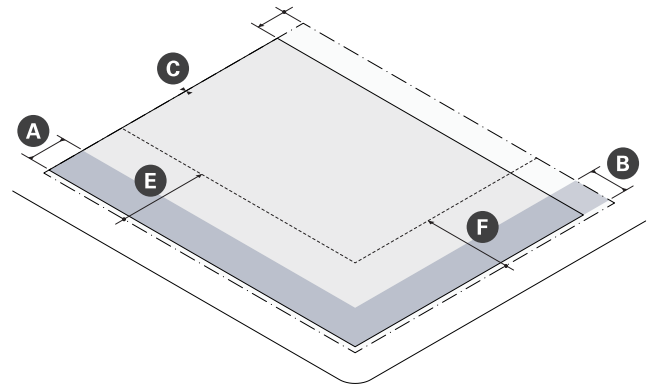

Building Setbacks		
A Primary Front SETBACK (min/max)	2 ft	12 ft
B Secondary Front SETBACK (min/max)	2 ft	12 ft
C Side SETBACK (min)	0 ft	
Side SETBACK ABUTTING NR or LHD (min)	10 ft	
D Rear SETBACK (min)	--	
ALLEY	0 ft	
No ALLEY	10 ft	
No ALLEY & ABUTTING NR or LHD	15 ft	

Parking Setbacks	
E Primary Front SETBACK (min)	--
SURFACE PARKING	30 ft
STRUCTURED PARKING	30 ft
F Secondary Front SETBACK (min)	--
SURFACE PARKING	10 ft
STRUCTURED PARKING	2 ft

4.2.7. Apartment Building (continued)

c. Massing & Height

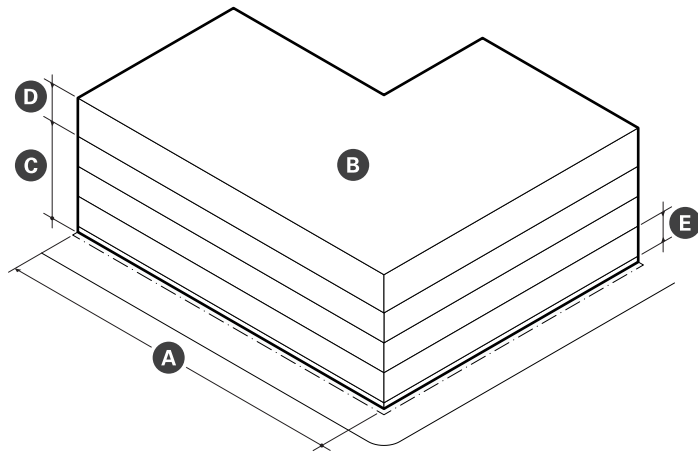

Main Massing	
A BUILDING WIDTH (max)	200 ft
FACADE Build Out (min)	–
Primary Front	80%
Secondary Front	65%
B FLOOR PLATE (max)	15,000 sf
GROUND STORY Elevation (min)	2 ft
C STORY Height (min)	10 ft
D Number of Stories (min/max)	3 4
E BUILDING Height, Feet (max)	50 ft
Roof Type	Flat

d. Uses & Features

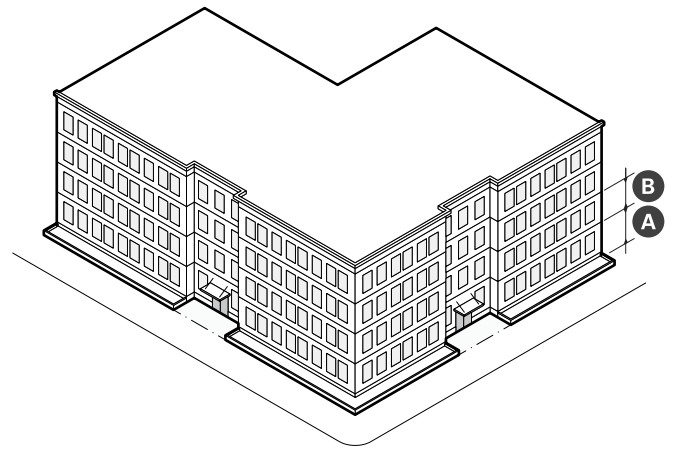

Facade Composition	
A GROUND STORY FENESTRATION (min/max)	20% 50%
B UPPER STORY FENESTRATION (min/max)	20% 50%
BLANK WALL (max)	20 ft

Use & Occupancy	
GROSS FLOOR AREA per DU	–
LOT AREA < 5,500 sf	1,500
LOT AREA >= 5,500 sf	1,125
NET ZERO BUILDING	850
100% AFFORDABLE HOUSING	850
OUTDOOR AMENITY SPACE (min)	1/DU

4. MID-RISE DISTRICTS

Mid-Rise 4 (MR4)

4.2.7. Apartment Building (continued)

- e. DEVELOPMENT Benefits
 - i. DEVELOPMENT is subject to the provisions of Article 12: DEVELOPMENT Benefits of this Ordinance. Where the provisions of this section conflict with those of Article 12, the provisions of Article 12 apply.
 - ii. DEVELOPMENT of a general building must provide AFFORDABLE DWELLING UNITS as specified on Table 4.2.7.
- f. Design Guidelines
 - i. GROUND STORY DWELLING UNITS should be elevated above the grade of any adjacent sidewalk so that the window sills of the DWELLING UNIT are at or above the eye-level of passing pedestrians. This elevation change maintains privacy for occupants while also encouraging open blinds or curtains to allow natural daylight into the unit.
 - ii. FENESTRATION patterns and window configurations should break the direct line of sight between neighboring properties to every extent practicable. Translucent glass on the bottom half of windows or strategically placed landscape elements should be utilized if it is not practical to off-set windows in such a way as to minimize privacy impacts.
 - iii. Outdoor AMENITY SPACES that are elevated, such as roof DECKS, fully projecting balconies, and UPPER STORY rear porches should, provide sight-obscuring visual screening at the sides to increase privacy, security, and to limit views of ABUTTING properties from elevated vantage points.

Table 4.2.7 Required ADUs

Total DWELLING UNITS	Required ADUs
0 to 5 units	None
6 units	1 unit OR fractional buyout for 0.4 units
7 units	1 unit OR fractional buyout for 0.6 units
8 to 17 units	17.5% of units
18 or more units	20% of units

4.2.8 General Building

A moderate FLOOR PLATE, multi-STORY PRINCIPAL BUILDING TYPE with GROUND STORY commercial space and no limitations on the occupancy of UPPER STORIES for permitted USES. The UPPER STORIES of a general BUILDING are typically residential, but a wide variety exists. As the number of stories increases, it becomes more likely for the UPPER STORIES of a general BUILDING to host commercial USES as well as residential.

The following images are examples of the general BUILDING TYPE and are intended only for illustrative purposes.



4. MID-RISE DISTRICTS

Mid-Rise 4 (MR4)

4.2.8. General Building (continued)

a. Lot Standards

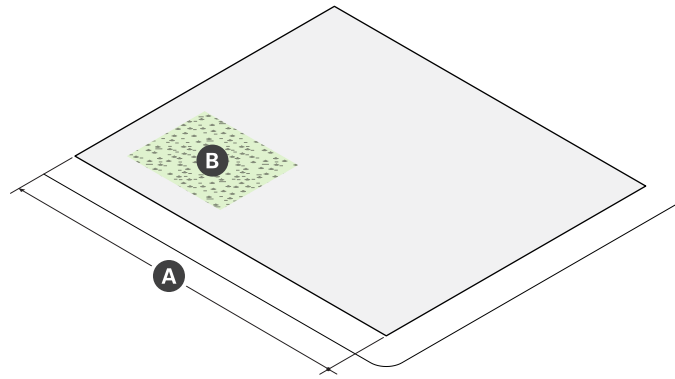

Lot Dimensions	
A LOT WIDTH (min)	30 ft

Lot Development	
LOT Coverage (max)	90%
GREEN SCORE	--
Minimum	0.25
Ideal	0.30
B OPEN SPACE (min)	15%

b. BUILDING Placement

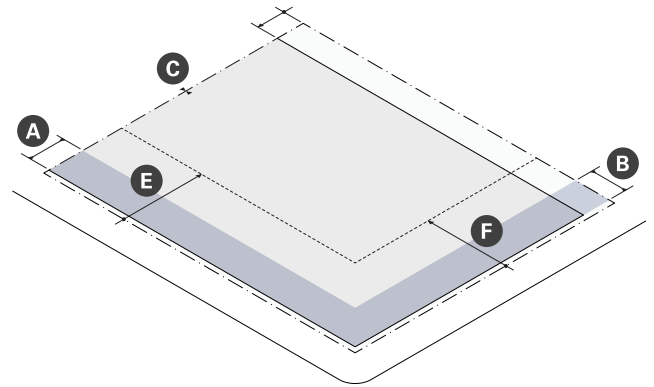

Building Setbacks		
A Primary Front SETBACK (min/max)	2 ft	15 ft
B Secondary Front SETBACK (min/max)	2 ft	15 ft
C Side SETBACK (min)	0 ft	
Side SETBACK ABUTTING NR or LHD (min)	10 ft	
D Rear SETBACK (min)	--	
ALLEY	0 ft	
No ALLEY	10 ft	
No ALLEY & ABUTTING NR or LHD	15 ft	

Parking Setbacks	
E Primary Front SETBACK (min)	--
SURFACE PARKING	30 ft
STRUCTURED PARKING	30 ft
F Secondary Front SETBACK (min)	--
SURFACE PARKING	10 ft
STRUCTURED PARKING	2 ft

4.2.8. General Building (continued)

c. Massing & Height

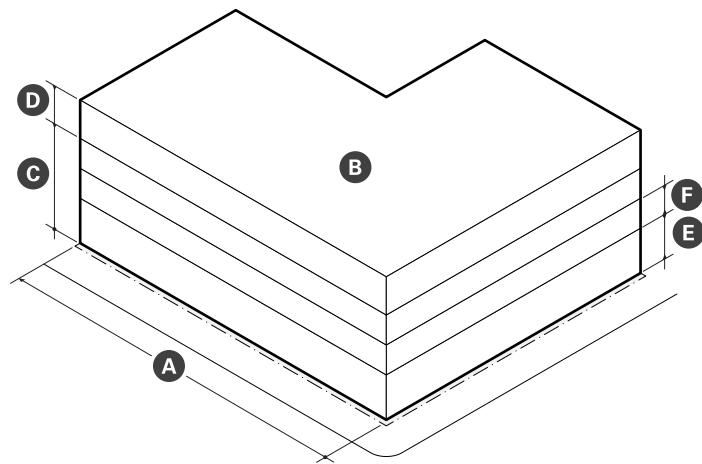

Main Massing	
A BUILDING WIDTH (max)	200 ft
FACADE Build Out, Primary Front (min)	–
Primary Front	80%
Secondary Front	65%
B FLOOR PLATE (max)	15,000 sf
C GROUND STORY Height (min)	14 ft
D UPPER STORY Height (min)	10 ft
E Number of Stories (min)	3 4
F BUILDING Height, Feet (max)	55 ft
Roof Type	Flat

d. Uses & Features

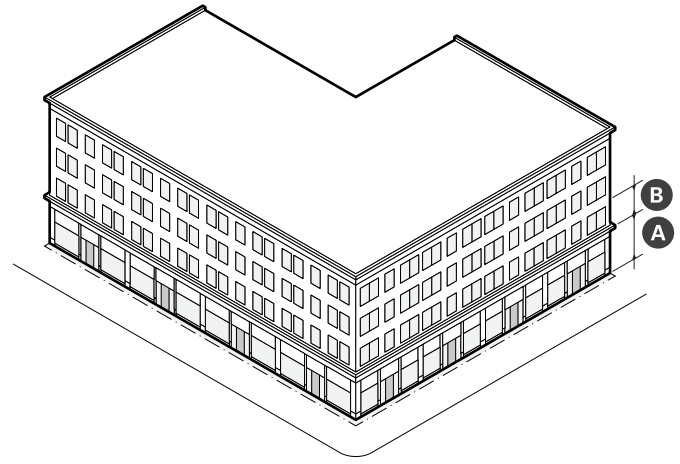

Facade Composition	
A GROUND STORY FENESTRATION (min)	70%
B UPPER STORY FENESTRATION (min/max)	20% 50%
BLANK WALL (max)	20 ft

Use & Occupancy	
GROUND STORY Entrance Spacing (max)	30 ft
Commercial Space Depth (min)	30 ft
GROSS FLOOR AREA per DU	–
LOT AREA < 5,500 sf	1,500
LOT AREA >= 5,500 sf	1,125
NET ZERO BUILDING	850
100% AFFORDABLE HOUSING	850
Outdoor AMENITY SPACE (min)	1/DU

4. MID-RISE DISTRICTS

Mid-Rise 4 (MR4)

4.2.8. General Building (continued)

- e. DEVELOPMENT Benefits
 - i. DEVELOPMENT is subject to the provisions of Article 12: DEVELOPMENT Benefits of this Ordinance. Where the provisions of this section conflict with those of Article 10, the provisions of Article 10 apply.
 - ii. DEVELOPMENT of a general building must provide AFFORDABLE DWELLING UNITS as specified on Table 4.2.8 (a).
 - iii. DEVELOPMENT of a general building must provide linkage payments as specified on Table 4.2.8 (b).
- f. Design Guidelines
 - i. FENESTRATION patterns and window configurations should break the direct line of sight between neighboring properties to every extent practicable. Translucent glass on the bottom half of windows or strategically placed landscape elements should be utilized if it is not practical to off-set windows in such a way as to minimize privacy impacts.
 - ii. Outdoor AMENITY SPACES that are elevated, such as roof DECKS, fully projecting balconies, and UPPER STORY rear porches should, provide sight-obscuring visual screening at the sides to increase privacy, security, and to limit views of ABUTTING properties from elevated vantage points.

Table 4.2.8 (a) Required ADUs

Total DWELLING UNITS	Required ADUs
0 to 5 units	None
6 units	1 unit OR fractional buyout for 0.4 units
7 units	1 unit OR fractional buyout for 0.6 units
8 to 17 units	17.5% of units
18 or more units	20% of units

Table 4.2.8 (b) Linkage

Commercial GROSS FLOOR AREA	Affordable Housing Linkage	Employment Linkage
30,000 sf or less	None	None
Over 30,000 sf	\$10/sf	\$2.46/sf

4.2.9 Commercial Building

A moderate FLOOR PLATE, multi-STORY, PRINCIPAL BUILDING TYPE purpose built for occupation by commercial uses on all stories. GROUND STORY commercial space is primarily occupied by commercial service, food & beverage service, or retail sales PRINCIPAL USES. Floor space on upper stories may be occupied by retail uses that do not rely on the visibility of a storefront at sidewalk level.

The following images are examples of the general BUILDING TYPE and are intended only for illustrative purposes.



4. MID-RISE DISTRICTS

Mid-Rise 4 (MR4)

4.2.9. Commercial Building (continued)

a. LOT Standards

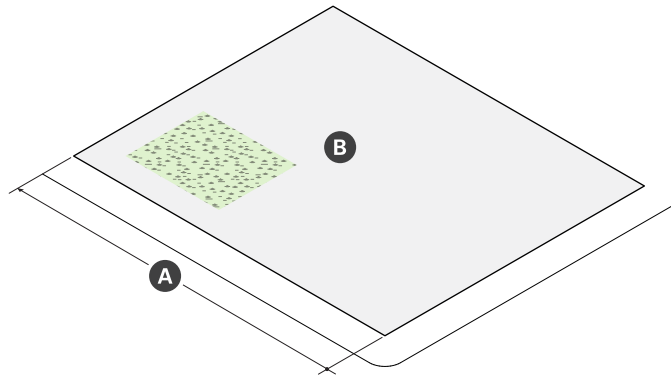

Lot Dimensions	
A LOT WIDTH (min)	30 ft

Lot Development	
LOT Coverage (max)	90%
GREEN SCORE	--
Minimum	0.25
Ideal	0.30
B OPEN SPACE (min)	15%

b. BUILDING Placement

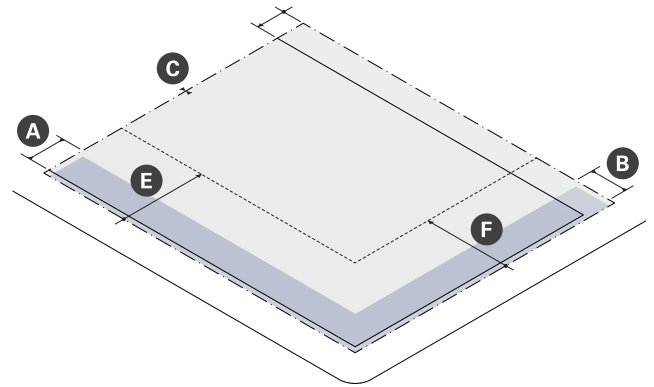

Building Setbacks		
A Primary Front SETBACK (min/max)	2 ft	15 ft
B Secondary Front SETBACK (min/max)	2 ft	15 ft
C Side SETBACK (min)	0 ft	
Side SETBACK ABUTTING NR or LHD (min)	10 ft	
D Rear SETBACK (min)	--	
ALLEY	0 ft	
No ALLEY	10 ft	
No ALLEY & ABUTTING NR or LHD	15 ft	

Parking Setbacks	
E Primary Front SETBACK (min)	--
SURFACE PARKING	30 ft
STRUCTURED PARKING	30 ft
F Secondary Front SETBACK (min)	--
SURFACE PARKING	10 ft
STRUCTURED PARKING	2 ft

4.2.9. Commercial Building (continued)

c. Massing & Height

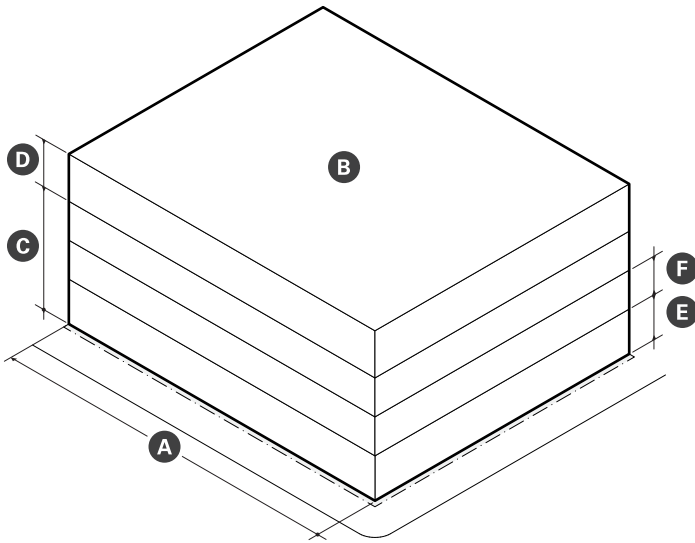

d. Uses & Features

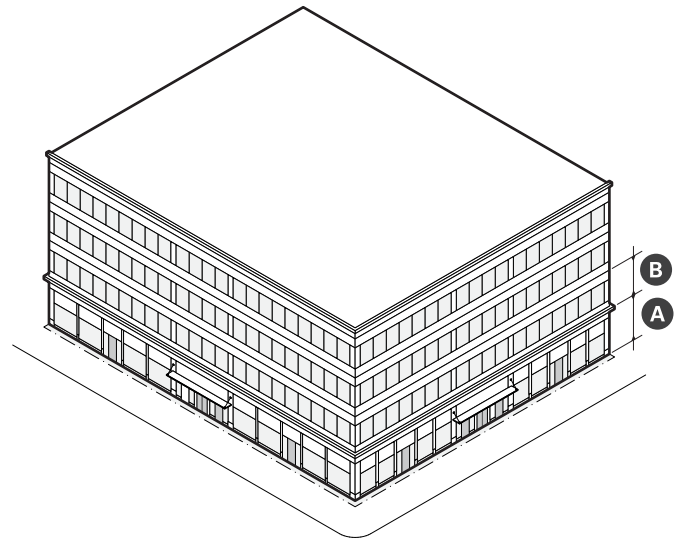

Main Massing	
A BUILDING WIDTH (max)	200 ft
FACADE Build Out, Primary Front (min)	–
Primary Front	80%
Secondary Front	65%
B FLOOR PLATE (max)	15,000 sf
C BUILDING HEIGHT, Stories (min)	3 stories
D BUILDING HEIGHT, Stories (max)	4 stories
E GROUND STORY HEIGHT (min)	14 ft
F UPPER STORY HEIGHT (min)	10 ft
BUILDING HEIGHT, Feet (max)	65 ft
Roof Type	Flat

Facade Composition	
A GROUND STORY FENESTRATION (min)	70%
B UPPER STORY FENESTRATION (min/max)	20% 70%
BLANK WALL (max)	20 ft

Use & Occupancy	
PRINCIPAL ENTRANCE Spacing (max)	30 ft
Commercial Space Depth (min)	30 ft

4. MID-RISE DISTRICTS

Mid-Rise 4 (MR4)

4.2.9. Commercial Building (continued)

- e. DEVELOPMENT Benefits
 - i. DEVELOPMENT is subject to the provisions of Article 12: DEVELOPMENT Benefits of this Ordinance. Where the provisions of this section conflict with those of Article 12, the provisions of Article 12 apply.
 - ii. DEVELOPMENT of a general building must provide linkage payments as specified on Table 4.2.9.

Table 4.2.9 Linkage

Commercial GROSS FLOOR AREA	Affordable Housing Linkage	Employment Linkage
30,000 sf or less	None	None
Over 30,000 sf	\$10/sf	\$2.46/sf

10. Building Components

- a. BUILDING COMPONENTS are ACCESSORY elements attached to the MAIN MASSING of a PRINCIPAL BUILDING.
- b. BUILDING COMPONENTS are permitted by Site Plan Approval as specified on Table 4.2.10.
 - i. At least one (1) storefront is required for each GROUND STORY commercial space.
- c. BUILDING COMPONENTS not identified on Table 4.2.10 are prohibited.
- d. Unless otherwise specified, BUILDING COMPONENTS may attach to other BUILDING COMPONENTS to create assemblies of components.

Table 4.2.10 Building Components

	Apartment BUILDING	General BUILDING	Commercial BUILDING
Awning	N	P	P
Entry Canopy	P	P	P
Lobby Entrance	P	P	P
Storefront	N	P	P
Stoop	P	N	N
Bay Window	P	P	P
Balcony	P	P	N
Arcade	N	N	N

P - Permitted SP - Special Permit Required N - Not Permitted

4. MID-RISE DISTRICTS

Mid-Rise 4 (MR4)

e. Awning

- i. An awning is a wall mounted frame covered with fabric or other material that provides shade and weather protection over a storefront or BUILDING entrance.

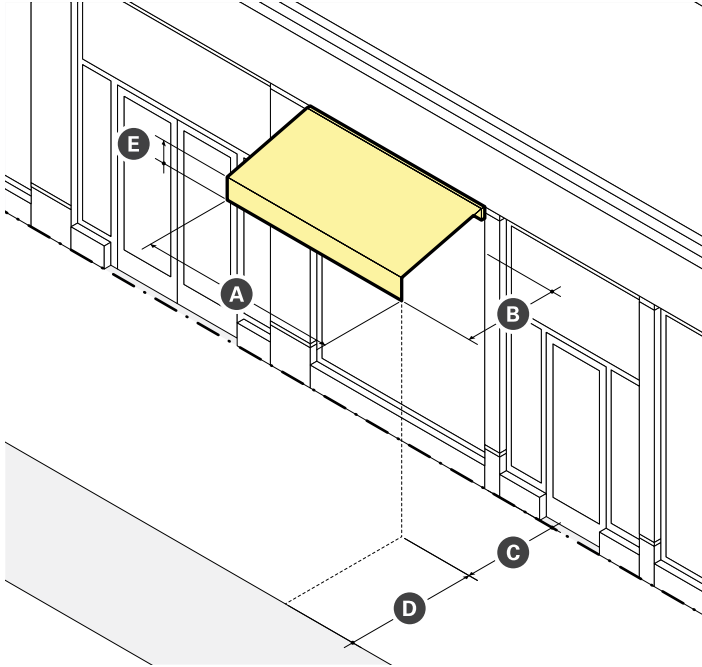

Dimensions	
A Width (min)	See ii Standards
B Projection (min)	3 ft
C CLEARANCE (min)	8 ft
Front SETBACK ENCROACHMENT (max)	100%
D SETBACK from Curb (min)	2 ft
E Valance Height (max)	12 in

- ii. Standards
 - a). Awnings must be securely attached to and supported by the BUILDING and must fit the windows or doors the awning is attached to.
 - b). An awning must be made of durable, weather-resistant material that is water repellent.
 - c). Internally illuminated or back-lit awnings are prohibited.
 - d). An awning that projects over the sidewalk of a public THOROUGHFARE requires compliance with all City Ordinances.

f. Entry Canopy

- i. An entry canopy is a wall-mounted STRUCTURE that provides shade and weather protection over a storefront or BUILDING entrance.

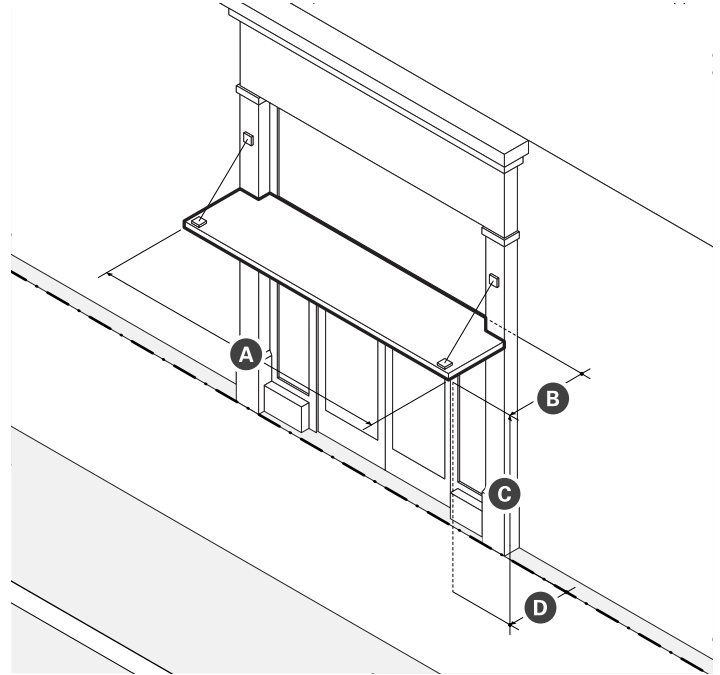

Dimensions	
A Width (min)	See ii Standards
B Projection (min)	3 ft
C CLEARANCE (min)	8 ft
D Front SETBACK ENCROACHMENT (max)	100%
SETBACK from Curb (min)	2 ft

- ii. Standards
 - a). Entry canopies must be visually supported by brackets, cables, or rods.
 - b). The width of an entry canopy must be equal to or greater than the width of the doorway surround or exterior casing it is mounted over.

g. Lobby Entrance

- i. A lobby entrance is a non-load bearing assembly of entry doors and windows providing ACCESS and light to the lobby of a BUILDING.

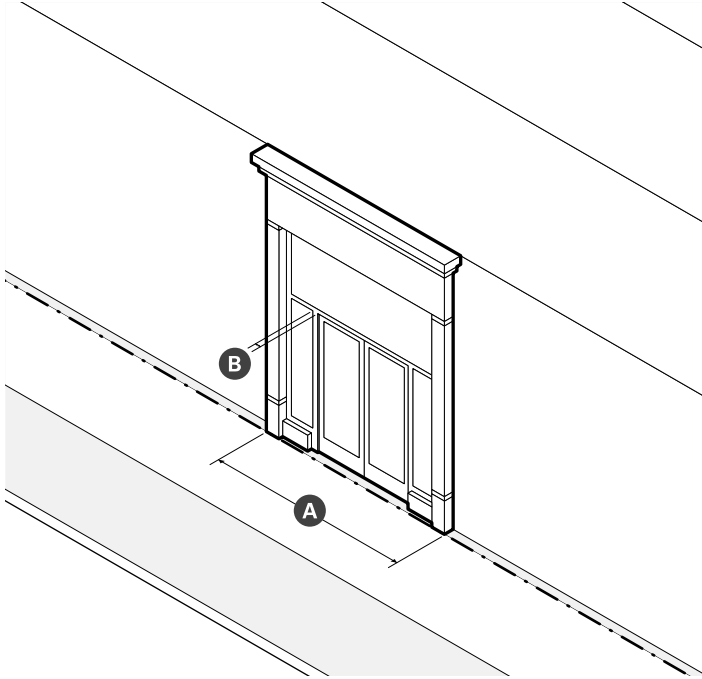

Dimensions		
A Width (min/max)	15 ft	30 ft
B Height (min)	80% of GROUND STORY Height	
Recessed Entrance Width (max)	15 ft	
Recessed Entrance Depth (max)	5 ft	

- ii. Standards
 - a). When a lobby entrance is set back from the FRONT LOT LINE, the FRONTAGE AREA must be paved.

h. Storefront

- i. A storefront is a non-load bearing assembly of commercial entry doors and windows providing ACCESS and light to a commercial space and a place to display goods, services, and SIGNS.

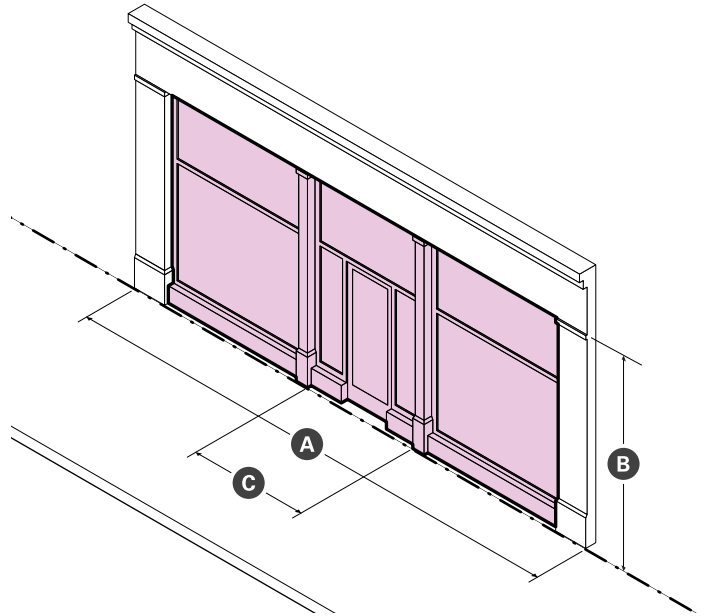

Dimensions		
A Width (min/max)	15 ft	30 ft
B Height (min)	80% of GROUND STORY Height	
Display Window Height (min)	8 ft	
Recessed Entrance Width (max)	15 ft	
Recessed Entrance Depth (max)	5 ft	

- ii. Standards
 - a). An unobstructed view of the interior space or a lighted and maintained merchandise display(s) must be provided for a depth of at least four (4) feet behind storefront display windows.
 - b). When storefronts are set back from the FRONT LOT LINE, the FRONTAGE AREA must be paved.
 - c). When present, awnings and canopies must be mounted between columns, PILASTERS, OR PIERS; above doorways and display windows; and below the SIGN BAND.
 - d). Exterior security grilles, gates, and roll-down security doors and windows are prohibited.

4. MID-RISE DISTRICTS

Mid-Rise 4 (MR4)

i. Stoop

- i. A stoop is a set of stairs with a landing leading to the entrance of a BUILDING.

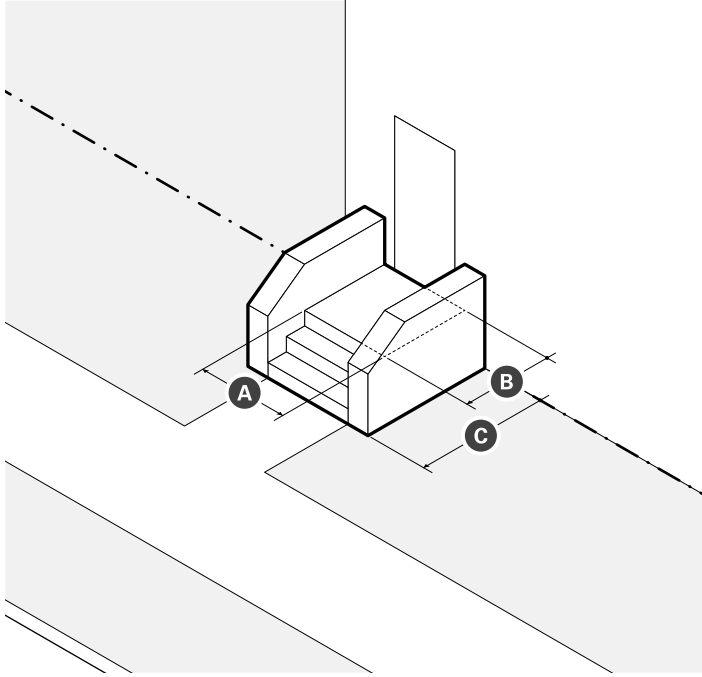

Dimensions	
A Landing Width (min)	4 ft
B Landing Depth (min)	4 ft
C Front SETBACK ENCROACHMENT (max)	100%

- ii. Standards
 - a). Paving, excluding driveways, must match the ABUTTING sidewalk unless paved with pervious, porous, or permeable materials.
 - b). Stairs may be recessed into the BUILDING FACADE when the BUILDING is set back four (4) feet or less.
 - c). Stairs are not permitted to ENCROACH onto any ABUTTING sidewalk.
 - d). Stairs may be built perpendicular or parallel to the BUILDING FACADE, but must lead directly to ground level or an ABUTTING sidewalk.

j. Bay Window

- i. A bay window is an assembly of windows projecting from a building to provide additional HABITABLE space, increased light, multi-directional views, and ARTICULATION to an exterior wall.

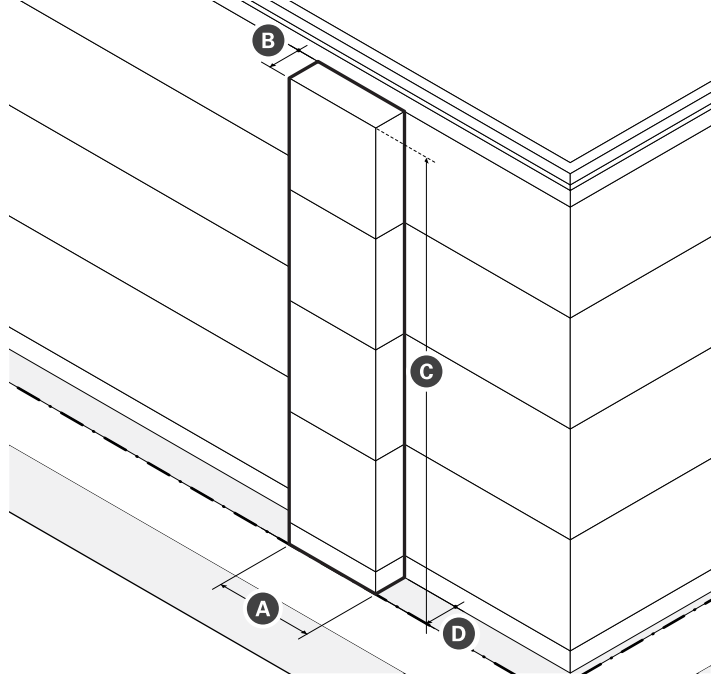

Dimensions	
A Width (max)	16 ft
B Projection (max)	3 ft
C Height (max)	Height of BUILDING in Stories
D Front SETBACK ENCROACHMENT (max)	3 ft
FENESTRATION (min)	60%

- ii. Standards
 - a). Bay windows, including box and bow windows, must include at least three (3) windows.
 - b). The cumulative width of multiple bays may equal up to fifty percent (50%) of the width of the exterior wall from which the bays project.
 - c). Bays projecting over the sidewalk of a public THOROUGHFARE must have at least two (2) stories of CLEARANCE and be compliant with all City Ordinances.

k. Balcony

- i. A balcony is a platform with a railing that provides outdoor AMENITY SPACE.

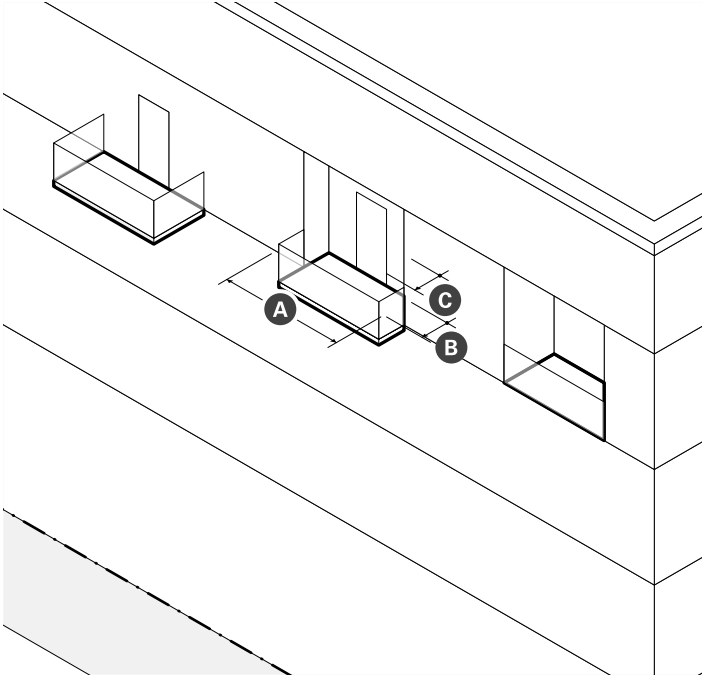

Dimensions	
A Width (min)	5 ft
B Depth (max)	5 ft
D Area (min)	50 ft
CLEARANCE (min)	10 ft
Permitted Front SETBACK ENCROACHMENT (max)	6 ft

- ii. Standards
 - a). Balconies may be recessed, projecting, a combination of the two, or terraced as part of the roof of a portico, porch, or bay.
 - b). A balcony that projects over the sidewalk of a public THOROUGHFARE requires compliance with all City Ordinances.
 - c). The guard rail of any balcony oriented toward a FRONT LOT LINE must permit visual supervision of the PUBLIC REALM through the posts and rails.
 - d). The guard rail of any balcony oriented toward a side OF REAR LOT LINE ABUTTING the NR district must include sight-obscuring visual screening so that it is at least fifty percent (50%) opaque.

l. Arcade

- i. An arcade is a pedestrian walkway covered by the upper floors of a BUILDING. The GROUND STORY FACADE is SETBACK and upper floors are supported by a colonnade or supports.

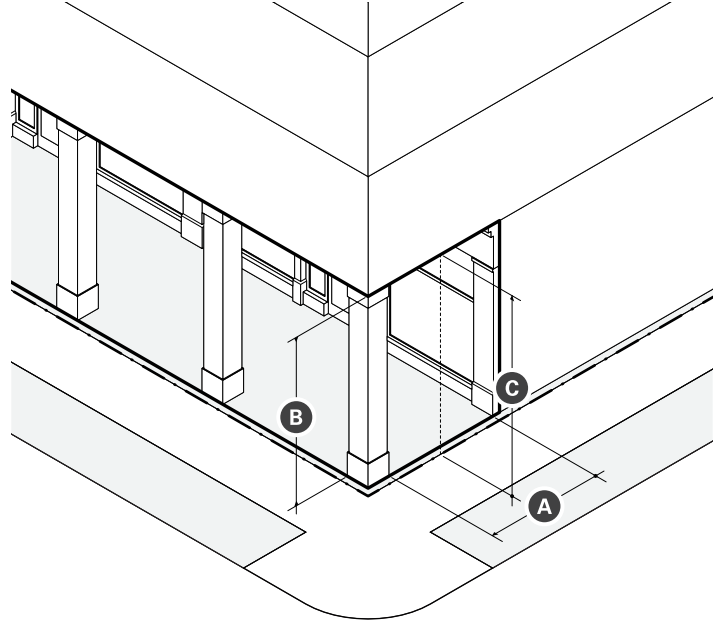

Dimensions		
A Depth (min/max)	10 ft	15 ft
B Height (max)	1 STORY	
C CLEARANCE (min/max)	14 ft	24 ft

- ii. Standards
 - a). Arcades must extend the entire width of a BUILDING and must have a consistent depth.
 - b). Support columns or PIERS may be spaced no farther apart than they are tall.
 - c). Arcades are considered part of the BUILDING for the purpose of measuring FACADE build out.
 - d). Arcades may be combined only with storefront and lobby entrance frontages.
 - e). The finished ceiling of an arcade interior may be arched or flat, but must have a greater CLEARANCE than the openings between columns OR PIERS.

4. MID-RISE DISTRICTS

Mid-Rise 4 (MR4)

11. Facade Design

- a. FACADES must provide solid material framing each storefront and lobby entrance as follows:
 - i. PILASTERS or columns supporting a horizontal lintel and CORNICE;
 - ii. a spandrel positioned between PILASTERS or columns that extend from upper stories of the building to the ground; or
 - iii. flat wall above and to either side of a void or punched opening.
- b. Storefronts and lobby entrances must be set within the resulting frame provided for each by the FACADE.
- c. Materials framing each storefront or lobby entrance may be integrated into the design of the FACADE or customized for individual storefronts and lobby entrances.
- d. Mechanical louvers necessary for venting purposes are not permitted in the required frame, but may be incorporated into any storefront or lobby entrance system.
- e. FACADES must differentiate the GROUND STORY of the building from the upper stories through horizontal ARTICULATION, a change in material, or a change in window size or pattern to create a distinct base to the building FACADE. The entire height of the GROUND STORY must be included in the FACADE base.
- f. For buildings with more than one FACADE, the design of the base must align horizontally at the corner.
- g. FACADES must provide surface relief from the average plane of the FACADE by at least four (4) inches, through

the USE of architectural elements such as bay windows, columns, CORNER BOARDS, CORNICES, door and window surrounds, moldings, PIERS, PILASTERS, recessed storefronts or lobby entrances, seat walls, sills, wall thickness, and recessed or projecting windows.

- h. The FACADE of any building greater than one hundred (100) feet in width must be designed as two (2) or more separate and distinct facades of differing architectural design so that the building appears to be multiple buildings. The facade designs must include a change in CORNICE, roof eave, or parapet design from one another.

12. Architectural Design Guidelines

- a. FACADES should be visually divided into a series of ARCHITECTURAL BAYS that are derived, in general, from the building's structural bay spacing.
- b. PIERS, PILASTERS, or other features defining each ARCHITECTURAL BAY should either extend all the way to the ground or terminate at any horizontal ARTICULATION defining the base of the building.
- c. ARCHITECTURAL BAYS should align, in general, with individual or groups of storefronts and lobby entrances.
- d. PIERS, PILASTERS, or other features defining each ARCHITECTURAL BAY should always project forward and be uninterrupted by any horizontal articulation, excluding any horizontal ARTICULATION USED to differentiate the base of the building.
- e. Vents, exhausts, and other utility features on building FACADES should be architecturally integrated into

Figure 4.2.11 (a) Storefront & Lobby Entrance Framing

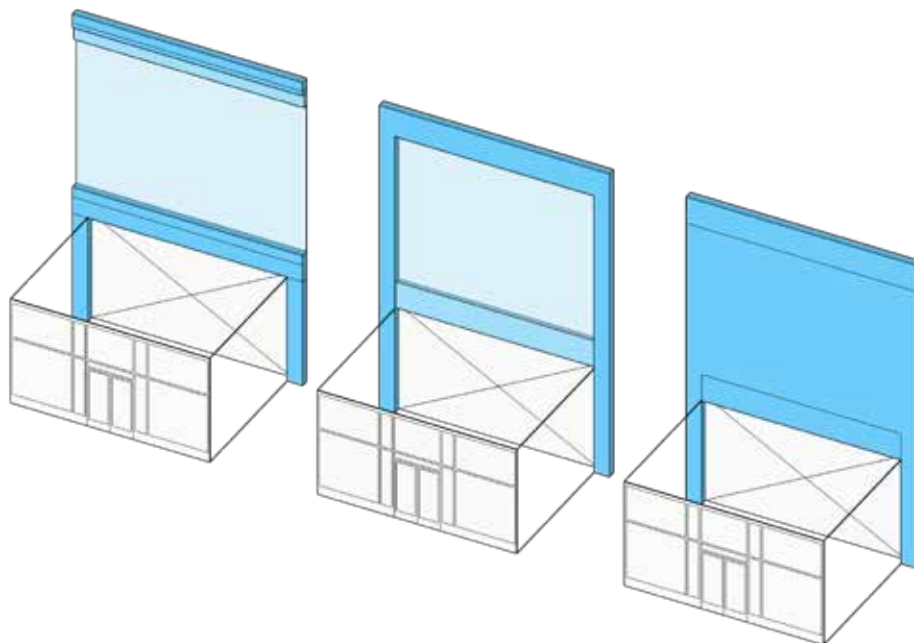

the design of the building and should be located to minimize adverse effects on pedestrian comfort along sidewalks and within OPEN SPACES.

- f. Buildings at TERMINATED VISTAS should be ARTICULATED with design features that function as focal points.
- g. FENESTRATION glazing should be inset from the plane of exterior wall surfaces.
- h. RIBBON WINDOWS should be avoided.
- i. Monotonous and repetitive storefront or lobby systems, awnings, canopies, SIGN types, colors, or designs should be avoided.
- j. Storefronts and lobby entrances should include awnings or canopies to provide weather protection for pedestrians and reduce glare for storefront display areas. Awnings should be open-ended and operable.
- k. Lobby entrances for UPPER STORY USES should be optimally located, well defined, clearly visible, and separate from the entrance for other GROUND STORY USES.
- l. Lobbies should be limited in both width and total area to preserve floor space and frontage for other GROUND STORY USES. Buildings should USE any combination of FACADE ARTICULATION, a double-height ceiling, a distinctive doorway, a change in wall material, a change in paving material within the FRONTAGE AREA, or some other architectural element(s) to make lobbies visual and materially distinctive.
- m. The selection of materials, FENESTRATION, and ornamentation should result in a consistent and harmonious composition that appears as a unified whole rather than a collection of unrelated parts, no

matter the style.

- n. The type and color of materials should be kept to a minimum, preferably three (3) or fewer.
- o. Two (2) or more wall materials should be combined only one above the other, except for bay windows.
- p. Wall materials appearing heavier in weight should be used below wall materials appearing lighter in weight (wood and metal above brick, and all three above stone)
- q. Horizontal or vertical board siding or shingles, regardless of material, should be avoided.
- r. Architectural details and finish materials for the base of a building should be constructed of architectural concrete or pre-cast cementitious panels, natural or cast stone, heavy gauge metal panels, glazed or unglazed architectural terracotta, or brick.
- s. Exterior Insulation and Finish Systems (EIFS) should be avoided.

Figure 4.2.11 (b) Appearance of Two Buildings



4. MID-RISE DISTRICTS

Mid-Rise 4 (MR4)

13. Use Provisions

- a. General
 - i. The USE of real property is subject to the provisions of Article 9: USE Provisions of this Ordinance. Where the provisions of this section conflict with those of Article 9, the provisions of Article 9 apply.
 - ii. USE categories are permitted as specified on Table 4.2.13. USE categories that are not identified on Table 4.2.13 are prohibited.
 - iii. All USES must comply with any USE-specific standards applicable for each USE in §9.2 USE Definitions & Limitations.
 - iv. USES permitted by Special Permit require additional DEVELOPMENT review in accordance with §15.2.1 Special Permits.
- b. USE Limitations
 - i. The USE of any GROUND STORY commercial space fronting a PEDESTRIAN STREET, excluding lobbies for UPPER STORY USES, is limited to the following PRINCIPAL USE categories:
 - a). Arts & Creative Enterprise
 - b). Food & Beverage Service
 - c). Retail Sales
 - d). Civic & Institutional
- c. Increases in Density
 - i. Existing STRUCTURES may not be altered to conflict with number of DWELLING UNITS permitted for each BUILDING TYPE.

Table 4.2.13 Permitted Uses

Use Category Specific Use	MR4
Arts & Creative Enterprise	
Artisinal Production	P
Arts Exhibition	P
Arts Sales & Services	P
Co-working	P
Design Services	P
Shared Workspaces & Arts Education	P
Cannabis Establishment	
Cannabis Cultivation	P
Cannabis Retail Sales	SP
Cannabis Research & Development	P
Cannabis Testing Laboratory	P
Civic & Institutional	
Community Center	P
Hospital	SP
Library	P
Minor Utility Facility	SP
Museum	P
Private Non-Profit Club or Lodge	SP
Public Service	P
Religious & Educational Uses Protected by M.G.L. 40A. Sec. 3	P

P - Permitted SP - Special Permit Required N - Not Permitted

Table 4.2.13 Permitted Uses (continued)

Use Category Specific Use	MR4
Commercial Services	
Animal Services (as noted below)	--
Commercial Kennel	SP
Pet Grooming	P
Pet Daycare & Training	SP
Veterinarian	SP
Assembly or Entertainment	SP
Banking & Financial Services (except as noted below)	P
Personal Credit	SP
Broadcast and/or Recording Studio	P
Building & Home Repair Services	SP
Business Support Services	P
Caterer/Wholesale Food Production	SP
Day Care Service (as noted below)	--
Adult Day Care Center	P
Child Day Care Center	P
Educational Services	P
Maintenance & Repair of Consumer Goods	P
Personal Services (except as noted below)	P
Body-Art Services	SP
Fitness Services	P
Funeral Services	SP
Health Care Services	SP
Formula Personal Services	SP
Recreation Services	SP
Vehicle Parking (except as follows)	--
Bike Share Parking	P
Car Share Parking (3 or fewer spaces)	P
Car Share Parking (4 or more spaces)	P
Commercial Parking	P
Food and Beverage Service	
Bar/Restaurant/Tavern	P
Bakery/Café/Coffee Shop	P
Formula Food & Beverage Service	SP

P - Permitted SP - Special Permit Required N - Not Permitted

Table 4.2.13 Permitted Uses (continued)

Use Category Specific Use	MR4
Lodging	
Bed & Breakfast	SP
Hotel or Hostel	SP
Office	
General Office	P
Research and Development and/or Laboratory	P
Residential	
Household Living	SP
Group Living (except as follows)	SP
Community or Group Residence	P
Dormitory, Fraternity or Sorority	SP
Homeless Shelter	SP
Nursing Home/Assisted Living Facility	SP
Rooming House	SP
Retail Sales	
Building/Home Supplies & Equipment	SP
Consumer Goods (except as follows)	P
Alcohol Sales	SP
Firearms Sales	N
Pet Store	SP
Formula Retail	SP
Fresh Food Market or Grocery Store	P
Farm/Vendor Market	P
Urban Agriculture	
Farming (as noted below)	--
Commercial Farming	P
Community Farming	P
Community Gardening	P

P - Permitted SP - Special Permit Required N - Not Permitted

4. MID-RISE DISTRICTS

Mid-Rise 4 (MR4)

Table 4.2.13 Permitted Uses (continued)

Use Category Specific Use	MR4
Accessory Uses	
Home Occupations (as noted below)	--
Home Office	P
Urban Agriculture (as noted below)	--
Apiculture	P
Aviculture	P
Commercial Farming	P
Residential Gardening	P
Vehicle Parking, Accessory (except as follows)	P
Home Business Vehicle Parking	N

P - Permitted SP - Special Permit Required N - Not Permitted

14. Development Standards

- a. General
 - i. DEVELOPMENT is subject to the provisions of Article 10: DEVELOPMENT STANDARDS of this Ordinance. Where the provisions of this section conflict with those of Article 10, the provisions of Article 10 apply.
- b. SIGNS
 - i. A SIGN, individual numerals or letters, or a nonelectrical nameplate identifying the property address is required for all real property as follows:
 - a). Each GROUND STORY non-residential USE must identify the STREET address either on the PRINCIPAL ENTRANCE door or above or beside the PRINCIPAL ENTRANCE of the USE.
 - b). All residential BUILDING TYPES must identify the STREET address either on the PRINCIPAL ENTRANCE door, above or beside the PRINCIPAL ENTRANCE, or on a mailbox.
 - ii. Address SIGNS must be made easily visible through the USE of colors or materials that contrast with the background material they are attached to and must be conspicuously located to provide visibility from the THOROUGHFARE that the BUILDING faces.
 - iii. Address SIGNS must be twelve (12) inches in height or less and may include the name of the occupant.

15. Parking & Mobility

- a. General
 - i. DEVELOPMENT is subject to the provisions of Article 11: Parking & Mobility of this Ordinance. Where the provisions of this section conflict with those of Article 11, the provisions of Article 11 apply.
 - ii. Vehicular parking must be provided as specified on Table 4.1 (d), except as follows:
 - a). Non-residential USES with five thousand (5,000) square feet or less of GROSS LEASABLE FLOOR AREA are exempt from any minimum requirements of Table 4.1. (d).
 - b). Any CHANGE IN USE within a non-residential STRUCTURE constructed before the effective date of this Ordinance, provided that the change is to a permitted USE, is exempt from any minimum requirements of Table 4.1 (d).
 - iii. There are no parking requirements for ACCESSORY USES.
 - iv. MOTOR VEHICLE PARKING spaces may be shared between USES on the same LOT and buildings on the same BLOCK in accordance with §11.3 SHARED PARKING.
- b. Type
 - i. MOTOR VEHICLE PARKING may be provided as SURFACE PARKING, above ground STRUCTURED PARKING, or underground STRUCTURED PARKING.
- c. Driveways
 - i. New driveways require a permit from the City Engineer.
 - ii. Driveways must be compliant with all City Ordinances and constructed in accordance with all standards established by relevant City Departments.
 - iii. Driveways are not permitted in the FRONTAGE AREA between a BUILDING and the FRONT LOT LINE.
 - iv. Driveways may be no wider than twenty four (24) feet in the FRONTAGE AREA of a LOT.
 - v. Driveways may provide ACCESS in whole or in part on or across an ABUTTING LOT(s), provided that an ACCESS EASEMENT exists between all PROPERTY OWNERS.
- d. Parking Design
 - i. The design of all parking is subject to §11.1 Bicycle Parking and §11.2 MOTOR VEHICLE PARKING of this Ordinance.
- e. Parking Location
 - i. Required vehicular parking, excluding any required handicapped parking, may be provided on a contiguous LOT under the same ownership as the LOT that the parking will serve as follows:
 - a). Pedestrian ACCESS to off-SITE vehicular parking must be via a paved sidewalk or walkway.
 - b). A lease, recorded covenant, or other comparable legal instrument guaranteeing long term USE of the SITE must be provided to the review board or BUILDING OFFICIAL and executed and filed with the Registry of Deeds.
 - ii. For real property located in more than one municipality, MOTOR VEHICLE PARKING need not be located within the City of Somerville.
- f. Unbundled Parking
 - i. MOTOR VEHICLE PARKING spaces must be rented or leased as an option rather than a requirement of the rental, lease, or purchase of a DWELLING UNIT or non-residential floor space.
 - ii. Bicycle parking must be provided at no cost or fee to customers, visitors, employees, tenants, and residents.
- g. Parking Relief
 - i. Relief from the parking standards of Table 4.2 (d) requires a Special Permit.
 - a). In addition to the review criteria for all Special Permits specified in §15.2.1.e. Review Criteria, the review board shall make findings considering the following in its discretion to approve or deny a special permit authorizing relief from the parking standards of Table 4.2 (d):
 - i). The supply and demand of on-STREET parking in the neighborhood, as determined through a parking study.
 - ii). MOBILITY MANAGEMENT programs and services provided by the APPLICANT to reduce the demand for parking.
 - iii). That parking provided in excess of any maximum permitted does not result in the increase in impervious LOT AREA.

16. Public Realm

- a. Sidewalks
 - i. When DEVELOPMENT OCCURS on any LOT ABUTTING a sidewalk that is less than twelve (12) feet in total width, the BUILDING must be set-back an additional distance to accommodate expansion of the ABUTTING sidewalk to a width of at least twelve (12) feet. The minimum and maximum front SETBACKS for each BUILDING TYPE are increased accordingly.
- b. Sidewalk CURB CUTS
 - i. A CURB CUT requires a permit from the City Engineer and must be compliant with all City Ordinances.
 - ii. Unless otherwise specified, the City Engineer may not permit more than one (1) CURB CUT per FRONT LOT LINE of a LOT.
 - iii. CURB CUTS are prohibited along all THOROUGHFARES designated as a PEDESTRIAN STREET.
 - iv. CURB CUTS must be located to minimize conflicts with pedestrians and bicyclists and must have a clear distance from fire hydrants, STREET TREES, utility

4. MID-RISE DISTRICTS

Mid-Rise 4 (MR4)

Table 4.2.15 Vehicular Parking

Use Category Specific Use	BICYCLE		MOTOR VEHICLE	
	Short-Term (min)	Long-Term (min)	Within a TRANSIT AREA ¹ (max)	Outside of a TRANSIT AREA ¹ (min)
Arts & Creative Enterprise				
All Permitted Uses	1 / 10,000 sf	1 / 3,000 sf	1 / 800 sf	1 / 1,000 sf
Cannabis Establishment				
Cannabis Retail Sales	1 / 2,500 sf	1 / 10,000 sf	1 / 1,500 sf	1 / 750 sf
Cannabis Research & Development	1 / 20,000 sf	1 / 5,000 sf	1 / 1,000 sf	1 / 1,000 sf
Cannabis Testing Laboratory	1 / 20,000 sf	1 / 5,000 sf	1 / 1,000 sf	1 / 1,000 sf
Civic & Institutional				
Community Center	1 / 10,000 sf	4 / 10,000 sf	1 / 1,800 sf	1 / 600 sf
Educational Facility	1.0 / classroom	4.0 / classroom	1.5 / classroom	3.0 / classroom
Hospital	10 per entrance	1 / 5,000 sf	1 / 200 sf	1 / 1,000 sf
Library	1 / 3,000 sf	1 / 5,000 sf	1 / 800 sf	1 / 500 sf
Minor Utility Facility	n/a	n/a	n/a	n/a
Museum	1 / 2,000 sf	1 / 10,000 sf	1 / 800 sf	1 / 500 sf
Private Non-Profit Club or Lodge	1 / 2,000 sf	1 / 10,000 sf	1 / 200 sf	1 / 1,000 sf
Commercial Services				
Animal Services (as noted below)	–	–	–	–
Commercial Kennel	1 / 2,500 sf	1 / 10,000 sf	1 / 500 sf	1 / 500 sf
Pet Grooming	1 / 2,500 sf	none	1 / 500 sf	1 / 500 sf
Pet Day Care or Training	1 / 2,500 sf	none	1 / 500 sf	1 / 500 sf
Veterinarian	1 / 2,500 sf	1 / 5,000 sf	1 / 500 sf	1 / 500 sf
Assembly or Entertainment	1 / 40 seats	1 / 10,000 sf	1 / 6 seats	1 / 6 seats
Banking & Financial Services (except as noted below)	1 / 2,000 sf	1 / 10,000 sf	1 / 450 sf	1 / 400 sf
Broadcast and/or Recording Studio	1 / 2,500 sf	1 / 10,000 sf	1 / 800 sf	1 / 600 sf
Building & Home Repair Services	1 / 2,500 sf	1 / 10,000 sf	1 / 1,000 sf	1 / 2,000 sf
Business Support Services	1 / 2,500 sf	1 / 10,000 sf	1 / 900 sf	1 / 600 sf
Caterer/Wholesale Food Production	1 / 2,500 sf	1 / 10,000 sf	1 / 800 sf	1 / 1,000 sf
Day Care Service	2	1 / 10,000 sf	1 / 900 sf	1 / 600 sf
Maintenance & Repair of Consumer Goods	1 / 2,500 sf	1 / 10,000 sf	1 / 750 sf	1 / 1,000 sf
Personal Services (except as noted below)	1 / 2,500 sf	1 / 10,000 sf	1 / 750 sf	1 / 1,000 sf
Health Care Services	1 / 2,000 sf	1 / 10,000 sf	1 / 500 sf	1 / 300 sf
Recreation Services	1 / 2,500 sf	1 / 10,000 sf	–	–

sf - Gross Leasable Square Footage

DU - Dwelling Unit RU - Rooming Unit

¹ See the Transit Area Map

Table 4.2.15 Vehicular Parking (continued)

Use Category Specific Use	BICYCLE		MOTOR VEHICLE	
	Short-Term (min)	Long-Term (min)	Within a TRANSIT AREA ¹ (max)	Outside of a TRANSIT AREA ¹ (min)
Food and Beverage Service				
All Permitted Uses	1 / 1,000 sf	1 / 5,000 sf	1 / 300 sf	1 / 500 sf
Lodging				
Bed & Breakfast	n/a	2.0	1 / DU + 1 / 4 guest rooms	1 / DU + 1 / 4 guest rooms
Hotel or Hostel	1 / 20 rooms	1 / 10 rooms	1 / 2 rooms	1 / 2 rooms
Office				
Co-Working	1 / 20,000 sf	1 / 3,000 sf	1 / 1,200 sf	1 / 800 sf
General Office	1 / 20,000 sf	1 / 3,000 sf	1 / 900 sf	1 / 650 sf
Research and Development and/or Laboratory	1 / 20,000 sf	1 / 5,000 sf	1 / 1,000 sf	1 / 1,000 sf
Residential				
Household Living	0.1 / DU	1.0 / DU	1.0 / DU	1.0 / DU
Group Living (except as follows)	0.05 / room	0.5 / room	--	--
Community or Group Residence	--	--	--	--
Dormitory, Fraternity or Sorority	0.1 / room	0.5 / room	.05 / bed	1.0 / 4 beds
Homeless Shelter	--	--	4.0	4.0
Nursing Home/Assisted Living Facility	--	--	1 / 6 beds	1 / 6 beds
Single Room Occupancy Housing	--	--	1 / 6 beds	1 / 4 beds
Retail Sales				
Building/Home Supplies & Equipment	1 / 2,500 sf	1 / 10,000 sf	1 / 1,000 sf	1 / 1,000 sf
Consumer Goods (except as follows)	1 / 2,500 sf	1 / 10,000 sf	1 / 1,500 sf	1 / 750 sf
Formula Retail	1 / 2,500 sf	1 / 10,000 sf	1 / 1,500 sf	1 / 750 sf
Fresh Food Market or Grocery Store	1 / 1,000 sf	1 / 10,000 sf	1 / 500 sf	1 / 1,500 sf
Farm/Vendor Market	n/a	n/a	n/a	1 / 1,500 sf

sf - Gross Leasable Square Footage DU - Dwelling Unit RU - Rooming Unit

¹ See the Transit Area Map

4. MID-RISE DISTRICTS

Mid-Rise 4 (MR4)

poles, and other furnishings as deemed necessary by the City Engineer.

- a). CURB CUTS for commercial or high-volume driveways should be at least one-hundred (100) feet from an UNSIGNALIZED or SIGNALIZED intersection.
- b). CURB CUTS for residential driveways should be at least twenty (20) feet from an UNSIGNALIZED intersection and at least forty (40) feet from a SIGNALIZED intersection.
- v. The interior width of a CURB CUT (between curb stones) may be no wider than the driveway, vehicular entrance, or loading facility it serves.
- vi. A DRIVEWAY APRON may be installed only within the furnishing zone of a sidewalk and must be constructed in accordance with all standards established by relevant City Departments.
- vii. The grade, cross slope, and clear width of the walkway of a sidewalk must be maintained between the DRIVEWAY APRON and the ABUTTING driveway. The appearance of the walkway (ie. scoring pattern or paving material) must indicate that, although a vehicle may cross, the area traversed by a vehicle remains part of the sidewalk.

Figure 4.2.16 Sidewalk Curb Cuts

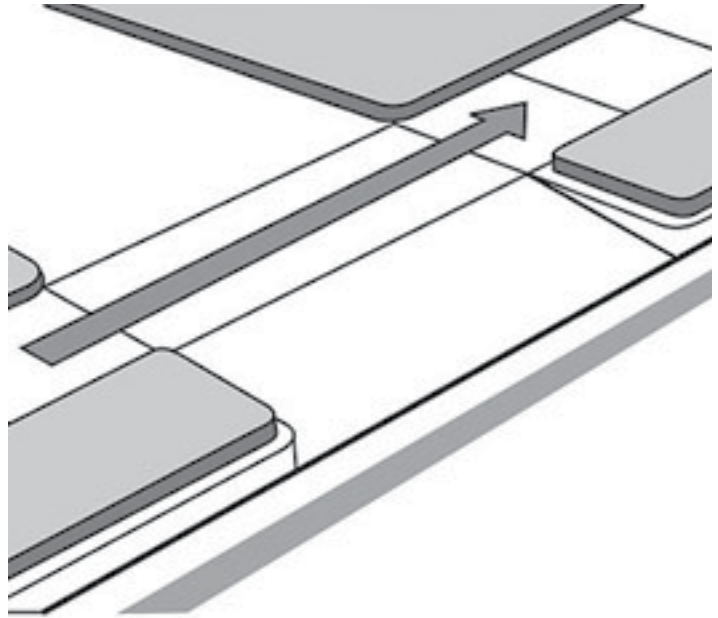

4.3 MID-RISE 5 (MR5)

1. Description

The Mid-Rise 5 district is characterized by a variety of moderate to large FLOOR PLATE buildings up to five (5) stories in height with an UPPER STORY STEP-BACK after the fourth (4th) floor. Buildings are set close to the sidewalk to create a defined STREET wall that supports pedestrian activity and a sense of place. The district is primarily commercial, with GROUND STORY USES that address the needs of residents and employees from the immediate neighborhood, but can also provide goods and services to the larger Somerville community and visitors from the broader Boston metropolitan area.

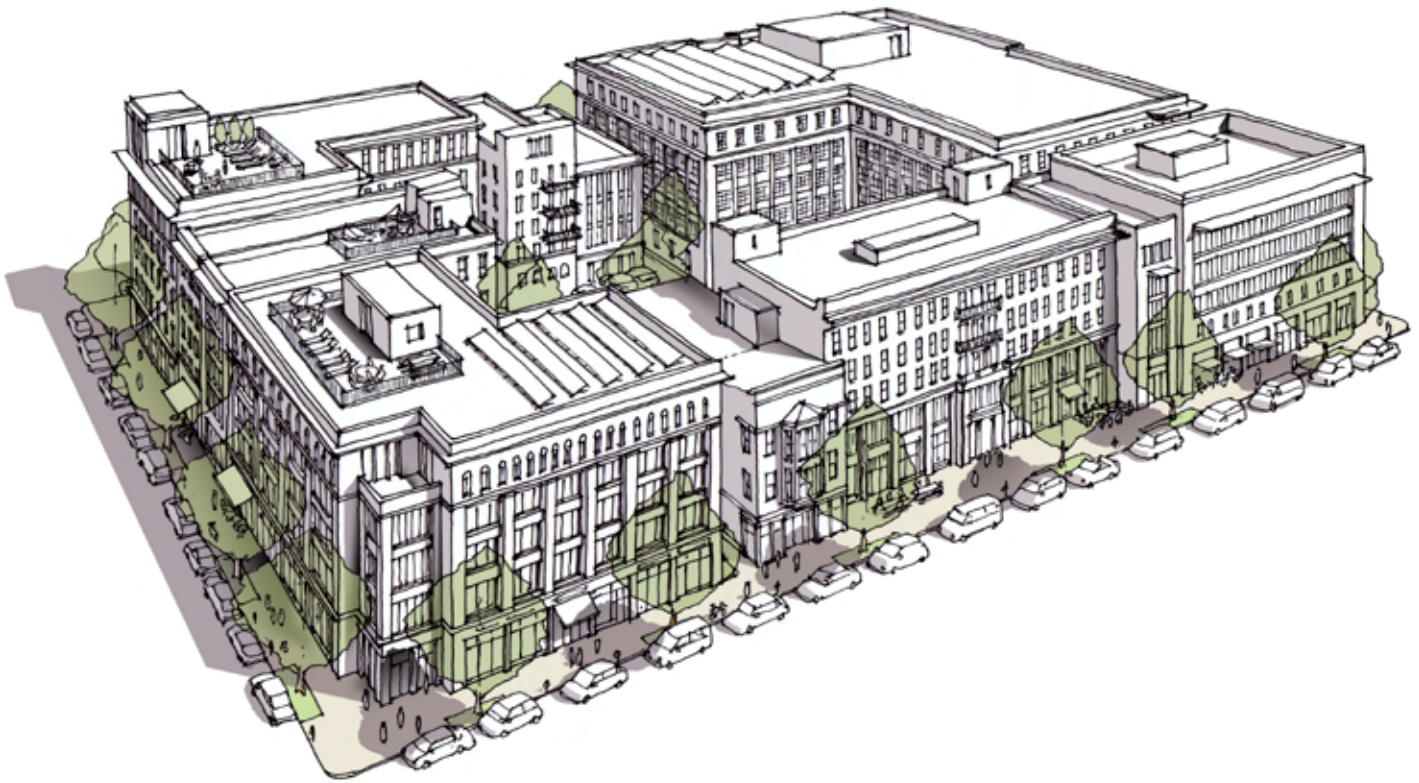

4. MID-RISE DISTRICTS

Mid-Rise 5 (MR5)

2. Intent

- a. To implement the objectives of the COMPREHENSIVE PLAN of the City of Somerville.
- b. To create, maintain, and enhance areas appropriate for moderate scale, multi-USE and mixed-USE buildings and neighborhood- and community-serving USES.

3. Purpose

- a. To permit the DEVELOPMENT of multi-unit and mixed-USE buildings that do not exceed five (5) stories in height.
- b. To provide quality commercial spaces and permit small and medium scale, neighborhood- and community-serving commercial USES.
- c. To create DWELLING UNIT types, sizes, and BEDROOM counts ideal for larger households in apartment buildings.
- d. To create DWELLING UNIT types, sizes, and BEDROOM counts ideal for smaller households in general buildings.
- e. To permit increased residential density for buildings that are sustainable or that provide 100% AFFORDABLE HOUSING.
- f. To permit increased residential density for buildings that meet the definition of a NET ZERO BUILDING or 100% AFFORDABLE HOUSING.

4. Applicability

- a. The section is applicable to all real property within the Mid-Rise 5 district as shown on the maps of the Official Zoning Atlas of the City of Somerville.

5. Development Review

- a. DEVELOPMENT review is subject to the provisions of Article 15: Administration of this Ordinance.
- b. All DEVELOPMENT, excluding NORMAL MAINTENANCE, requires the submittal of a development review application to the BUILDING OFFICIAL and the issuance of a Certificate of Zoning Compliance prior to the issuance of a BUILDING Permit or Certificate of Occupancy.
- c. Proposed DEVELOPMENT may or may not necessitate the need for SUBDIVISION Plan Approval, Site Plan Approval, a Special Permit, or a Hardship Variance based on the nature of the proposal. In such cases, additional DEVELOPMENT review is required in accordance with Article 15: Administration.
 - i. The Planning Board is the decision making authority for all DEVELOPMENT that requires Site Plan Approval or a Special Permit.
 - ii. The Zoning Board of Appeals is the Review Board for all HARDSHIP Variances.
- d. Upon verification that no additional DEVELOPMENT review is necessary, or completion of the required DEVELOPMENT review, the BUILDING OFFICIAL shall issue a Zoning Compliance CERTIFICATE to certify compliance with the

provisions and procedures of this Ordinance.

6. Building Types

- a. One (1) PRINCIPAL BUILDING TYPE is permitted on each LOT.
- b. The following BUILDING TYPES are permitted by Site Plan Approval in the Mid-Rise 5 district:
 - i. Apartment BUILDING
 - ii. General BUILDING
 - iii. Commercial BUILDING
- c. Apartment Buildings are prohibited on any LOT fronting a PEDESTRIAN STREET.
- d. ACCESSORY STRUCTURES are regulated according to Article 10: DEVELOPMENT Standards of this Ordinance.

4.3.7 Apartment Building

A moderate FLOOR PLATE, multi-STORY, PRINCIPAL BUILDING TYPE purpose built for OCCUPATION by residential USES on all stories.

The following images are examples of the apartment BUILDING TYPE and are intended only for illustrative purposes.



4. MID-RISE DISTRICTS

Mid-Rise 5 (MR5)

4.3.7. Apartment Building (continued)

a. Lot Standards

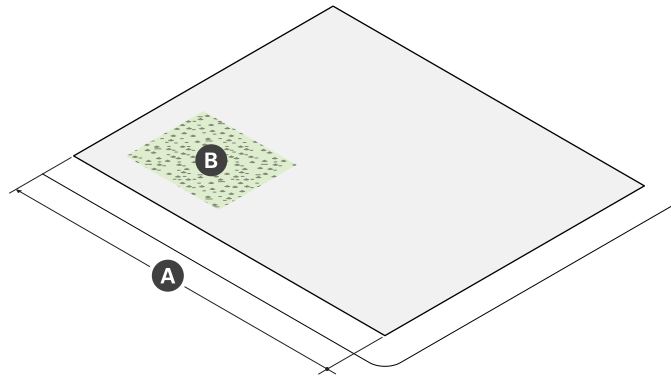

Lot Dimensions	
A LOT WIDTH (min)	30 ft

Lot Development	
LOT Coverage (max)	90%
GREEN SCORE	--
Minimum	0.20
Ideal	0.25
B OPEN SPACE (min)	15%

b. BUILDING Placement

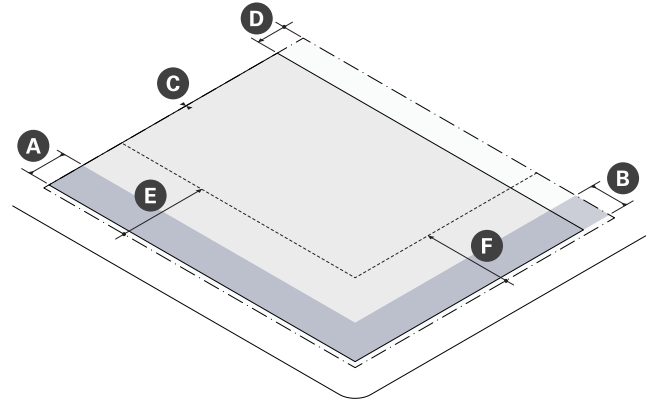

Building Setbacks		
A Primary Front SETBACK (min/max)	2 ft	12 ft
B Secondary Front SETBACK (min/max)	2 ft	12 ft
C Side SETBACK (min)	0 ft	
Side SETBACK ABUTTING NR or LHD (min)	10 ft	
D Rear SETBACK (min)	--	
ALLEY	0 ft	
No ALLEY	10 ft	
No ALLEY & ABUTTING NR or LHD	15 ft	

Parking Setbacks	
E Primary Front SETBACK (min)	--
SURFACE PARKING	30 ft
STRUCTURED PARKING	30 ft
F Secondary Front SETBACK (min)	--
SURFACE PARKING	10 ft
STRUCTURED PARKING	2 ft

4.3.7. Apartment Building (continued)

c. Massing & Height

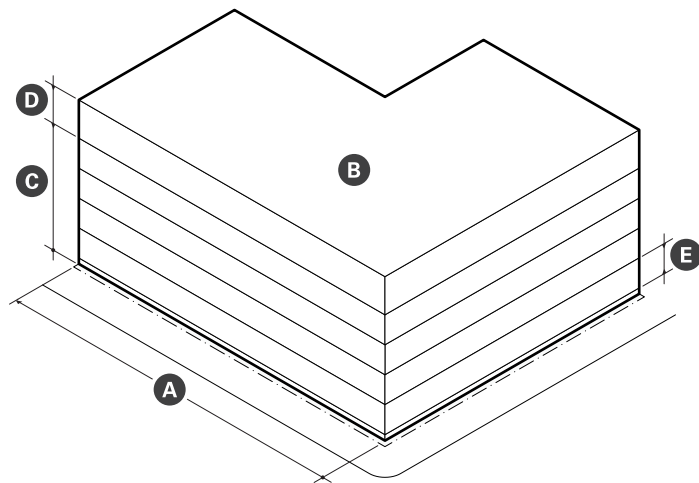

d. Uses & Features

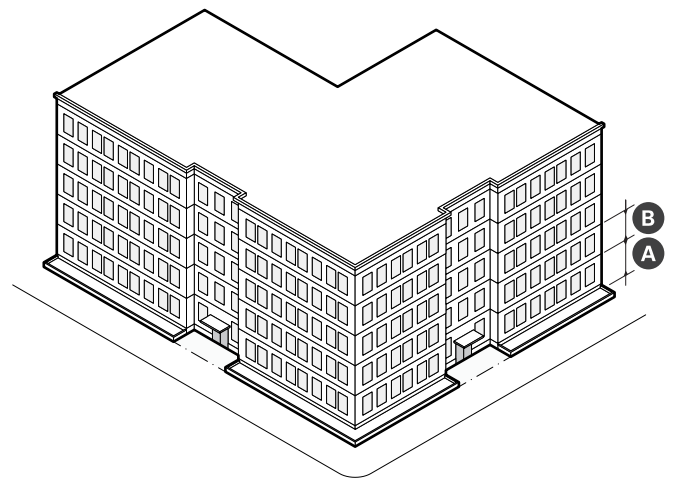

Main Massing	
A BUILDING WIDTH (max)	200 ft
FACADE Build Out, Primary Front (min)	--
Primary Front	80%
Secondary Front	65%
B FLOOR PLATE (max)	20,000 sf
GROUND STORY Elevation (min)	2 ft
C GROUND STORY Height	10 ft
D BUILDING Height, Stories (min/max)	3 5
E UPPER STORY STEP-BACK (min)	--
Primary/Secondary Front	10 ft
Side/Rear ABUTTING NR	30 ft
F BUILDING Height, Feet (max)	60 ft
Roof Type	Flat

Facade Composition	
A GROUND STORY FENESTRATION (min/max)	20% 50%
B UPPER STORY FENESTRATION (min/max)	20% 50%
BLANK WALL (max)	20 ft

Use & Occupancy	
GROSS FLOOR AREA per DU	--
LOT AREA < 5,500 sf	1,500
LOT AREA >= 5,500 sf	1,125
NET ZERO BUILDING	850
100% AFFORDABLE HOUSING	850
OUTDOOR AMENITY SPACE (min)	1/DU

4. MID-RISE DISTRICTS

Mid-Rise 5 (MR5)

4.3.7. Apartment Building (continued)

- e. DEVELOPMENT Benefits
 - i. DEVELOPMENT is subject to the provisions of Article 12: DEVELOPMENT Benefits of this Ordinance. Where the provisions of this section conflict with those of Article 12, the provisions of Article 12 apply.
 - ii. DEVELOPMENT of a general building must provide AFFORDABLE DWELLING UNITS as specified on Table 4.3.7.
- f. Design Guidelines
 - i. GROUND STORY DWELLING UNITS should be elevated above the grade of any adjacent sidewalk so that the window sills of the DWELLING UNIT are at or above the eye-level of passing pedestrians. This elevation change maintains privacy for occupants while also encouraging open blinds or curtains to allow natural daylight into the unit.
 - ii. FENESTRATION patterns and window configurations should break the direct line of sight between neighboring properties to every extent practicable. Translucent glass on the bottom half of windows or strategically placed landscape elements should be utilized if it is not practical to off-set windows in such a way as to minimize privacy impacts.
 - iii. Outdoor AMENITY SPACES that are elevated, such as roof DECKS, fully projecting balconies, and UPPER STORY rear porches should, provide sight-obscuring visual screening at the sides to increase privacy, security, and to limit views of ABUTTING properties from elevated vantage points.

Table 4.3.7 Required ADUs

Total DWELLING UNITS	Required ADUs
0 to 5 units	None
6 units	1 unit OR fractional buyout for 0.4 units
7 units	1 unit OR fractional buyout for 0.6 units
8 to 17 units	17.5% of units
18 or more units	20% of units

4.3.8 General Building

A moderate FLOOR PLATE, multi-STORY PRINCIPAL BUILDING TYPE with GROUND STORY commercial space and no limitations on the occupancy of UPPER STORIES for permitted USES. The UPPER STORIES of a general BUILDING are typically residential, but a wide variety exists. As the number of stories increases, it becomes more likely for the UPPER STORIES of a general BUILDING to host commercial USES as well as residential.

The following images are examples of the general BUILDING TYPE and are intended only for illustrative purposes.



4. MID-RISE DISTRICTS

Mid-Rise 5 (MR5)

4.3.8. General Building (continued)

a. LOT Standards

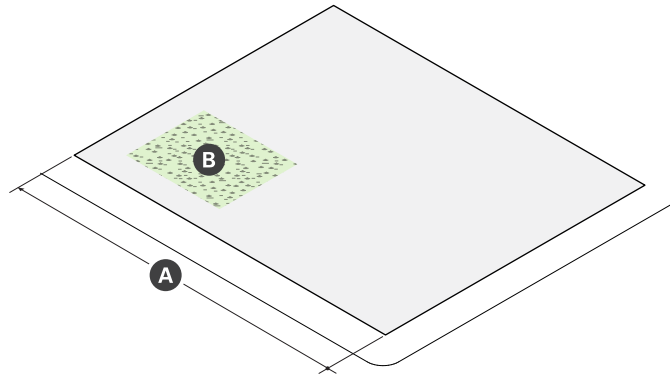

Lot Dimensions	
A LOT WIDTH (min)	30 ft

Lot Development	
LOT Coverage (max)	90%
GREEN SCORE	--
Minimum	0.20
Ideal	0.25
B OPEN SPACE (min)	15%

b. BUILDING Placement

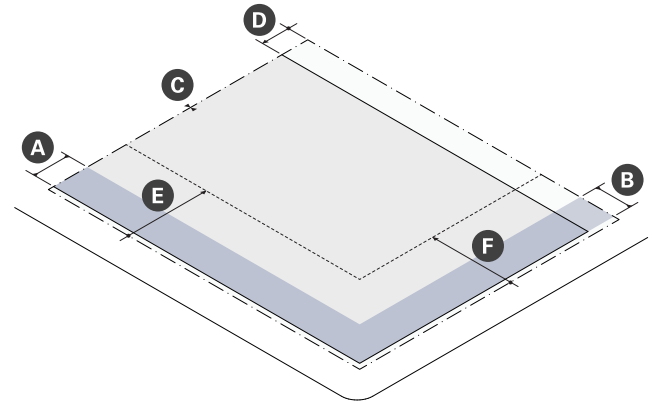

Building Setbacks		
A Primary Front SETBACK (min/max)	2 ft	15 ft
B Secondary Front SETBACK (min/max)	2 ft	15 ft
C Side SETBACK (min)	0 ft	
Side SETBACK ABUTTING NR or LHD (min)	10 ft	
D Rear SETBACK (min)	--	
ALLEY	0 ft	
No ALLEY	10 ft	
No ALLEY & ABUTTING NR or LHD	15 ft	

Parking Setbacks	
E Primary Front SETBACK (min)	--
SURFACE PARKING	30 ft
STRUCTURED PARKING	30 ft
F Secondary Front SETBACK (min)	--
SURFACE PARKING	10 ft
STRUCTURED PARKING	2 ft

4.3.8. General Building (continued)

c. Massing & Height

d. Uses & Features

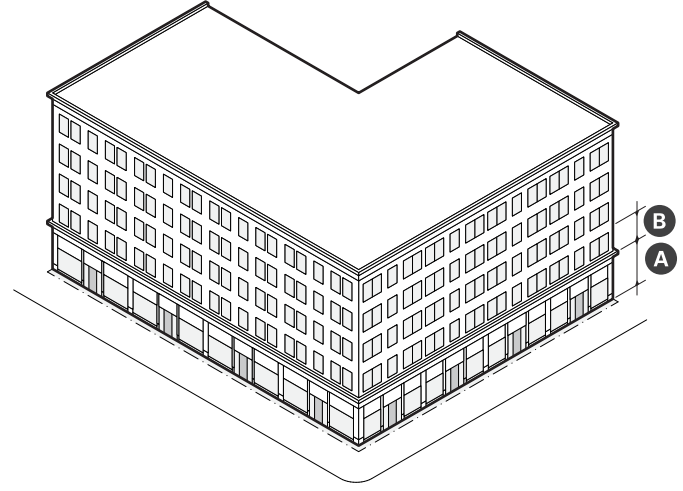
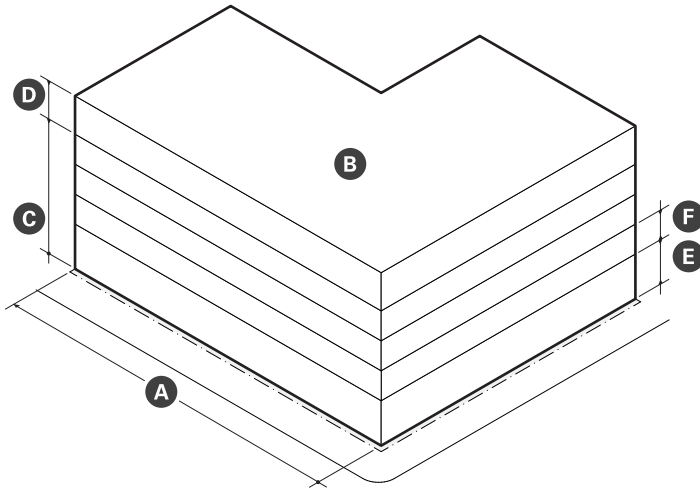

Main Massing	
A BUILDING WIDTH (max)	200 ft
FACADE Build Out (min)	--
Primary Front	80%
Secondary Front	65%
B FLOOR PLATE (max)	20,000 sf
C GROUND STORY Height	14 ft
D UPPER STORY Height	10 ft
E Number of Stories (min/max)	3 5
F UPPER STORY STEP-BACK (min)	--
Primary/Secondary Front	10 ft
Side/Rear ABUTTING NR	30 ft
G BUILDING Height, Feet (max)	65 ft
Roof Type	Flat

Facade Composition	
A GROUND STORY FENESTRATION (min)	70%
B UPPER STORY FENESTRATION (min/max)	20% 50%
BLANK WALL (max)	20 ft

Use & Occupancy	
GROUND STORY Entrance Spacing (max)	30 ft
Commercial Space Depth (min)	30 ft
GROSS FLOOR AREA per DU	--
LOT AREA < 5,500 sf	1,500
LOT AREA >= 5,500 sf	1,125
NET ZERO BUILDING	850
100% AFFORDABLE HOUSING	850
Outdoor AMENITY SPACE (min)	1/DU

4. MID-RISE DISTRICTS

Mid-Rise 5 (MR5)

4.3.8. General Building (continued)

- e. DEVELOPMENT Benefits
 - i. DEVELOPMENT is subject to the provisions of Article 12: DEVELOPMENT Benefits of this Ordinance. Where the provisions of this section conflict with those of Article 12, the provisions of Article 12 apply.
 - ii. DEVELOPMENT of a general building must provide AFFORDABLE DWELLING UNITS as specified on Table 4.3.8 (a).
 - iii. DEVELOPMENT of a general building must provide linkage payments as specified on Table 4.3.8 (b).
- f. Design Guidelines
 - i. FENESTRATION patterns and window configurations should break the direct line of sight between neighboring properties to every extent practicable. Translucent glass on the bottom half of windows or strategically placed landscape elements should be utilized if it is not practical to off-set windows in such a way as to minimize privacy impacts.
 - ii. Outdoor AMENITY SPACES that are elevated, such as roof DECKS, fully projecting balconies, and UPPER STORY rear porches should, provide sight-obscuring visual screening at the sides to increase privacy, security, and to limit views of ABUTTING properties from elevated vantage points.

Table 4.3.8 (a) Required ADUs

Total DWELLING UNITS	Required ADUs
0 to 5 units	None
6 units	1 unit OR fractional buyout for 0.4 units
7 units	1 unit OR fractional buyout for 0.6 units
8 to 17 units	17.5% of units
18 or more units	20% of units

Table 4.3.8 (b) Linkage

Commercial GROSS FLOOR AREA	Affordable Housing Linkage	Employment Linkage
30,000 sf or less	None	None
Over 30,000 sf	\$10/sf	\$2.46/sf

4.3.9 Commercial Building

A moderate FLOOR PLATE, multi-STORY, PRINCIPAL BUILDING TYPE purpose built for occupation by commercial uses on all stories. GROUND STORY commercial space is primarily occupied by commercial service, food & beverage service, or retail sales PRINCIPAL USES. Floor space on upper stories may be occupied by retail uses that do not rely on the visibility of a storefront at sidewalk level.

The following images are examples of the commercial BUILDING TYPE and are intended only for illustrative purposes.



4. MID-RISE DISTRICTS

Mid-Rise 5 (MR5)

4.3.9. Commercial Building (continued)

a. LOT Standards

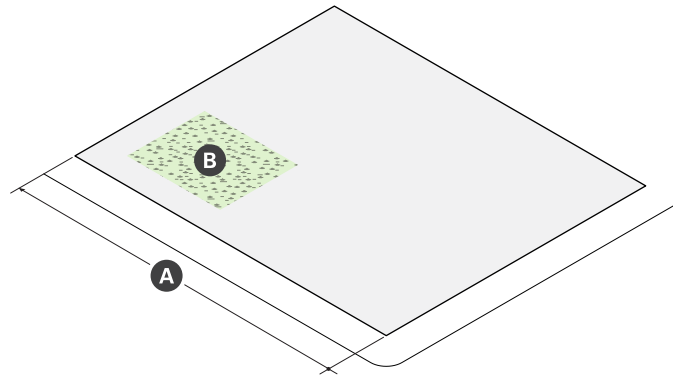

Lot Dimensions	
A LOT WIDTH (min)	30 ft

Lot Development	
LOT Coverage (max)	90%
GREEN SCORE	--
Minimum	0.20
Ideal	0.25
B OPEN SPACE (min)	15%

b. BUILDING Placement

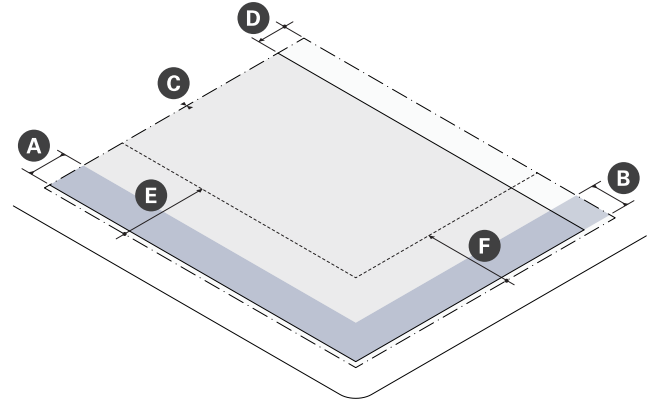

Building Setbacks		
A Primary Front SETBACK (min/max)	2 ft	15 ft
B Secondary Front SETBACK (min/max)	2 ft	15 ft
C Side SETBACK (min)	0 ft	
Side SETBACK ABUTTING NR or LHD (min)	10 ft	
D Rear SETBACK (min)	--	
ALLEY	0 ft	
No ALLEY	10 ft	
No ALLEY & ABUTTING NR or LHD	15 ft	

Parking Setbacks	
E Primary Front SETBACK (min)	--
SURFACE PARKING	30 ft
STRUCTURED PARKING	30 ft
F Secondary Front SETBACK (min)	--
SURFACE PARKING	10 ft
STRUCTURED PARKING	2 ft

4.3.9. Commercial Building (continued)

c. Massing & Height

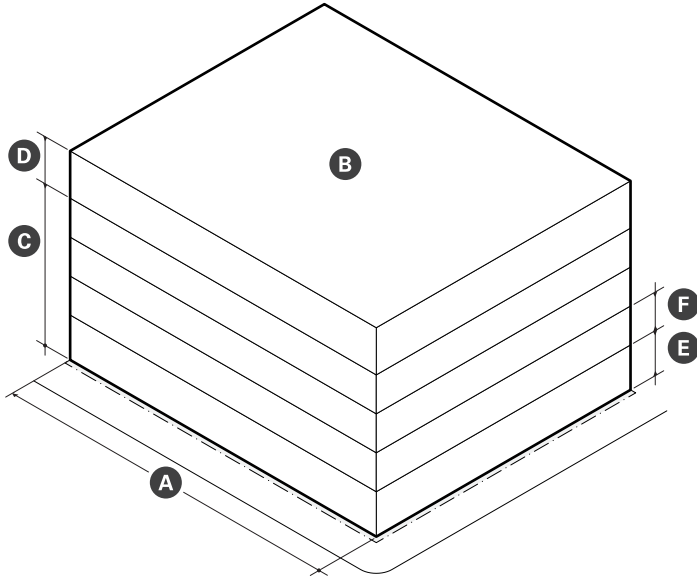

d. Uses & Features

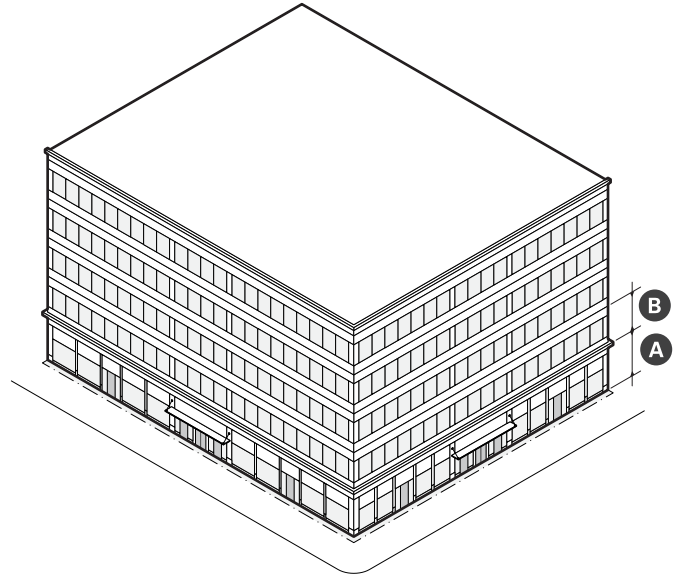

Main Massing	
A BUILDING WIDTH (max)	200 ft
FACADE Build Out (min)	–
Primary Front	80%
Secondary Front	65%
B FLOOR PLATE (max)	20,000 sf
C GROUND STORY Height	14 ft
D UPPER STORY Height	10 ft
E Number of Stories (min/max)	3 5
F UPPER STORY STEP-BACK (min)	–
Primary/Secondary Front	10 ft
Side/Rear ABUTTING NR	30 ft
G BUILDING Height, Feet (max)	75 ft
Roof Type	Flat

Facade Composition	
A GROUND STORY FENESTRATION (min)	70%
B UPPER STORY FENESTRATION (min/max)	20% 70%
BLANK WALL (max)	20 ft

Use & Occupancy	
GROUND STORY Entrance Spacing (max)	30 ft
Commercial Space Depth (min)	30 ft

4. MID-RISE DISTRICTS

Mid-Rise 5 (MR5)

4.3.9. Commercial Building (continued)

- e. DEVELOPMENT Benefits
 - i. DEVELOPMENT is subject to the provisions of Article 12: DEVELOPMENT Benefits of this Ordinance. Where the provisions of this section conflict with those of Article 12, the provisions of Article 12 apply.
 - ii. DEVELOPMENT of a general building must provide linkage payments as specified on Table 4.3.9.

Table 4.3.9 Linkage

Commercial GROSS FLOOR AREA	Affordable Housing Linkage	Employment Linkage
30,000 sf or less	None	None
Over 30,000 sf	\$10/sf	\$2.46/sf

10. Building Components

- a. BUILDING COMPONENTS are ACCESSORY elements attached to the MAIN MASSING of a PRINCIPAL BUILDING.
- b. BUILDING COMPONENTS are permitted by Site Plan Approval as specified on Table 4.3.10.
 - i. At least one (1) storefront is required for each GROUND STORY commercial space.
- c. BUILDING COMPONENTS that are not identified on Table 4.2.10 are prohibited.
- d. Unless otherwise specified, BUILDING COMPONENTS may attach to other BUILDING COMPONENTS to create assemblies of components.

Table 4.3.10 Building Components

	Apartment Building	General Building	Commercial Building
Awning	N	P	P
Entry Canopy	P	P	P
Lobby Entrance	P	P	P
Storefront	N	P	P
Stoop	P	N	N
Bay Window	P	P	P
Balcony	P	P	N
Arcade	N	N	N

P - Permitted SP - Special Permit Required N - Not Permitted

4. MID-RISE DISTRICTS

Mid-Rise 5 (MR5)

e. Awning

- i. An awning is a wall mounted frame covered with fabric or other material that provides shade and weather protection over a storefront or BUILDING entrance.

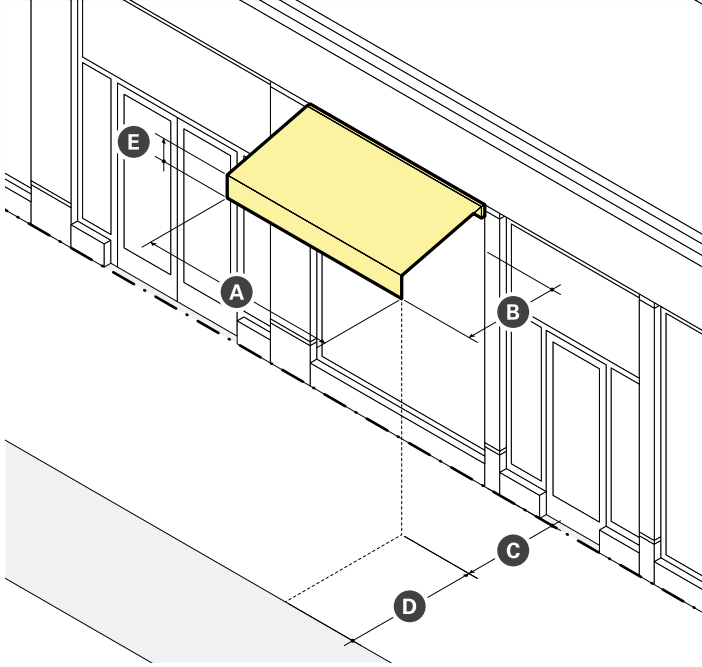

Dimensions	
A Width (min)	See ii Standards
B Projection (min)	3 ft
C CLEARANCE (min)	8 ft
Front SETBACK ENCROACHMENT (max)	100%
D SETBACK from Curb (min)	2 ft
E Valance Height (max)	12 in

- ii. Standards
 - a). Awnings must be securely attached to and supported by the BUILDING and must fit the windows or doors the awning is attached to.
 - b). An awning must be made of durable, weather-resistant material that is water repellent.
 - c). Internally illuminated or back-lit awnings are prohibited.
 - d). An awning that projects over the sidewalk of a public THOROUGHFARE requires compliance with all City Ordinances.

f. Entry Canopy

- i. An entry canopy is a wall-mounted STRUCTURE that provides shade and weather protection over a storefront or BUILDING entrance.

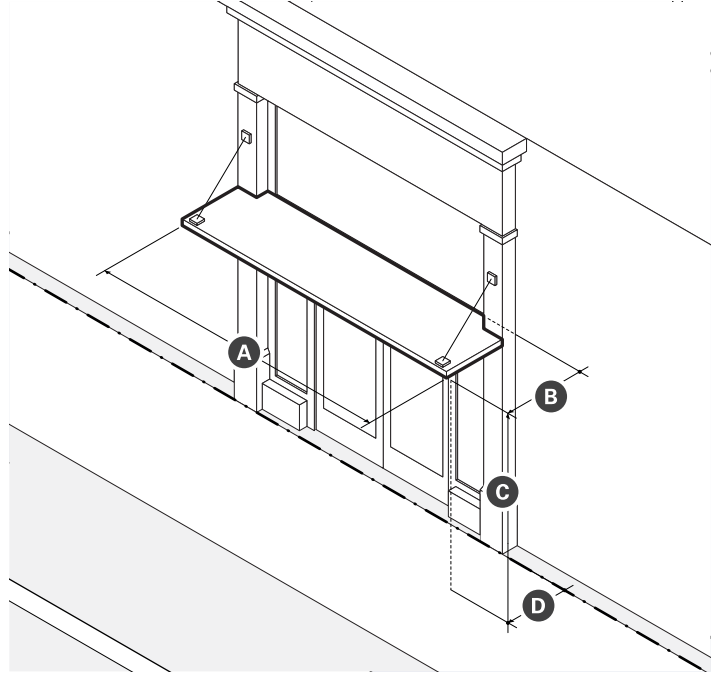

Dimensions	
A Width (min)	See ii Standards
B Projection (min)	3 ft
C CLEARANCE (min)	8 ft
D Front SETBACK ENCROACHMENT (max)	100%
SETBACK from Curb (min)	2 ft

- ii. Standards
 - a). Entry canopies must be visually supported by brackets, cables, or rods.
 - b). The width of an entry canopy must be equal to or greater than the width of the doorway surround or exterior casing it is mounted over.

g. Lobby Entrance

- i. A lobby entrance is a non-load bearing assembly of entry doors and windows providing ACCESS and light to the lobby of a BUILDING.

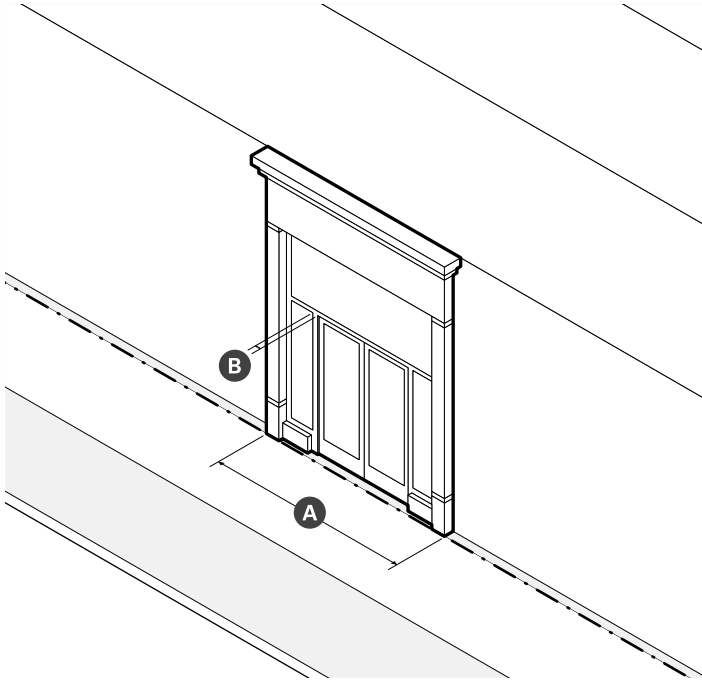

Dimensions		
A Width (min/max)	15 ft	30 ft
B Height (min)	80% of GROUND STORY Height	
Recessed Entrance Width (max)	15 ft	
Recessed Entrance Depth (max)	5 ft	

- ii. Standards
 - a). When a lobby entrance is set back from the FRONT LOT LINE, the FRONTAGE AREA must be paved.

h. Storefront

- i. A storefront is a non-load bearing assembly of commercial entry doors and windows providing ACCESS and light to a commercial space and a place to display goods, services, and SIGNS.

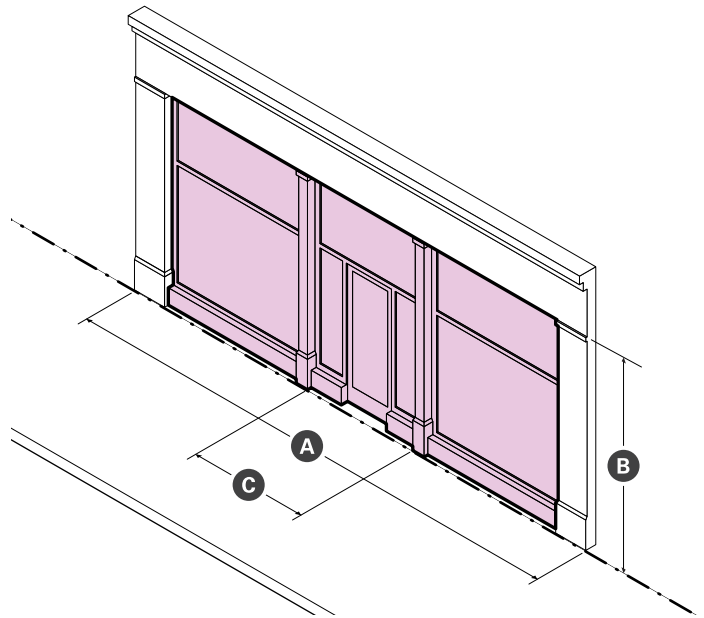

Dimensions		
A Width (min/max)	15 ft	30 ft
B Height (min)	80% of GROUND STORY Height	
Display Window Height (min)	8 ft	
Recessed Entrance Width (max)	15 ft	
Recessed Entrance Depth (max)	5 ft	

- ii. Standards
 - a). An unobstructed view of the interior space or a lighted and maintained merchandise display(s) must be provided for a depth of at least four (4) feet behind storefront display windows.
 - b). When storefronts are set back from the FRONT LOT LINE, the FRONTAGE AREA must be paved.
 - c). When present, awnings and canopies must be mounted between columns, PILASTERS, OR PIERS; above doorways and display windows; and below the SIGN BAND.
 - d). Exterior security grilles, gates, and roll-down security doors and windows are prohibited.

4. MID-RISE DISTRICTS

Mid-Rise 5 (MR5)

i. Stoop

- i. A stoop is a set of stairs with a landing leading to the entrance of a BUILDING.

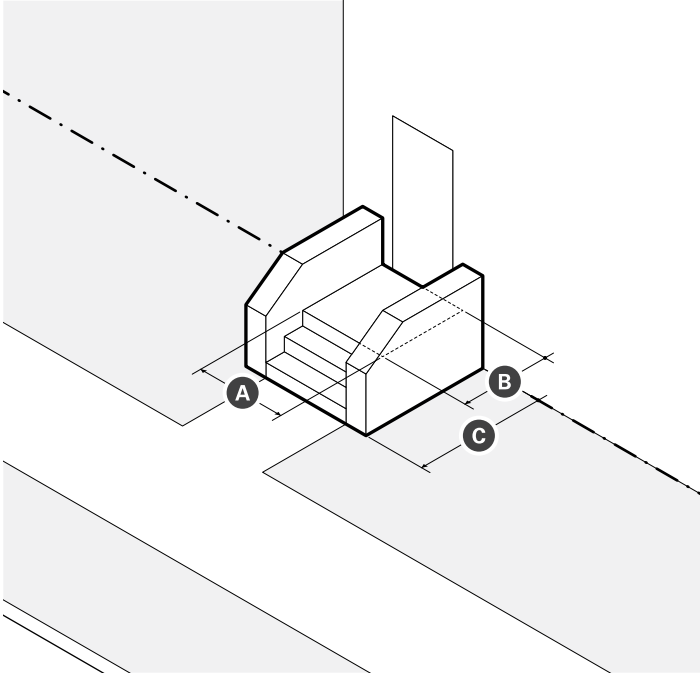

Dimensions	
A Landing Width (min)	4 ft
B Landing Depth (min)	4 ft
C Front SETBACK ENCROACHMENT (max)	100%

- ii. Standards
 - a). Paving, excluding driveways, must match the ABUTTING sidewalk unless paved with pervious, porous, or permeable materials.
 - b). Stairs may be recessed into the BUILDING FACADE when the BUILDING is set back four (4) feet or less.
 - c). Stairs are not permitted to ENCROACH onto any ABUTTING sidewalk.
 - d). Stairs may be built perpendicular or parallel to the BUILDING FACADE, but must lead directly to ground level or an ABUTTING sidewalk.

j. Bay Window

- i. A bay window is an assembly of windows projecting from a building to provide additional HABITABLE space, increased light, multi-directional views, and ARTICULATION to an exterior wall.

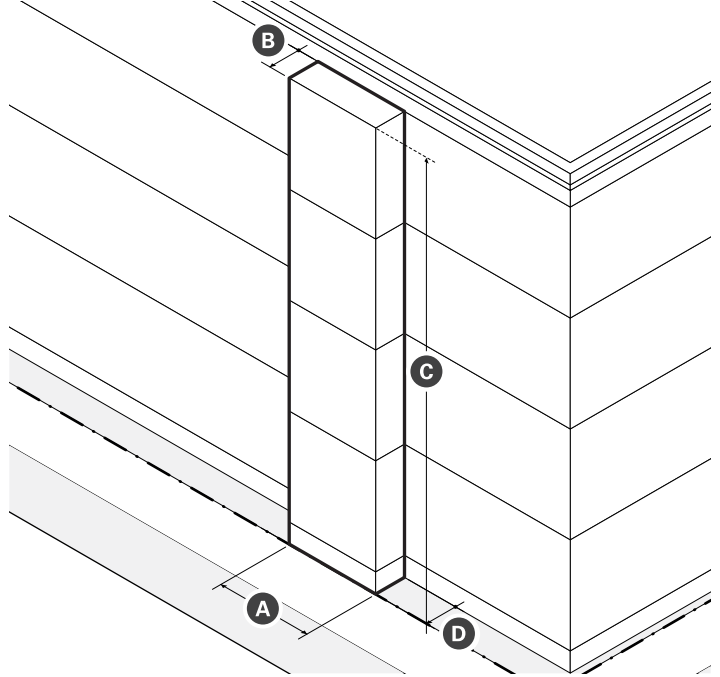

Dimensions	
A Width (max)	16 ft
B Projection (max)	3 ft
C Height (max)	Height of BUILDING in Stories
D Front SETBACK ENCROACHMENT (max)	3 ft
FENESTRATION (min)	60%

- ii. Standards
 - a). Bay windows, including box and bow windows, must include at least three (3) windows.
 - b). The cumulative width of multiple bays may equal up to fifty percent (50%) of the width of the exterior wall from which the bays project.
 - c). Bays projecting over the sidewalk of a public THOROUGHFARE must have at least two (2) stories of CLEARANCE and be compliant with all City Ordinances.

k. Balcony

- i. A balcony is a platform with a railing that provides outdoor AMENITY SPACE.

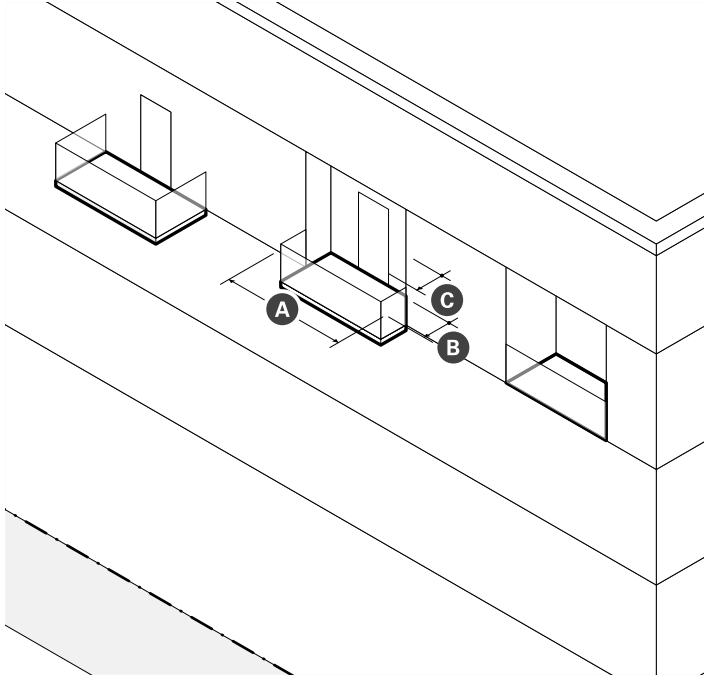

Dimensions	
A Width (min)	5 ft
B Depth (max)	5 ft
D Area (min)	50 ft
CLEARANCE (min)	10 ft
Permitted Front SETBACK ENCROACHMENT (max)	6 ft

- ii. Standards
 - a). Balconies may be recessed, projecting, a combination of the two, or terraced as part of the roof of a portico, porch, or bay.
 - b). A balcony that projects over the sidewalk of a public THOROUGHFARE requires compliance with all City Ordinances.
 - c). The guard rail of any balcony oriented toward a FRONT LOT LINE must permit visual supervision of the PUBLIC REALM through the posts and rails.
 - d). The guard rail of any balcony oriented toward a side OF REAR LOT LINE ABUTTING the NR district must include sight-obscuring visual screening so that it is at least fifty percent (50%) opaque.

l. Arcade

- i. An arcade is a pedestrian walkway covered by the upper floors of a BUILDING. The GROUND STORY FACADE is SETBACK and upper floors are supported by a colonnade or supports.

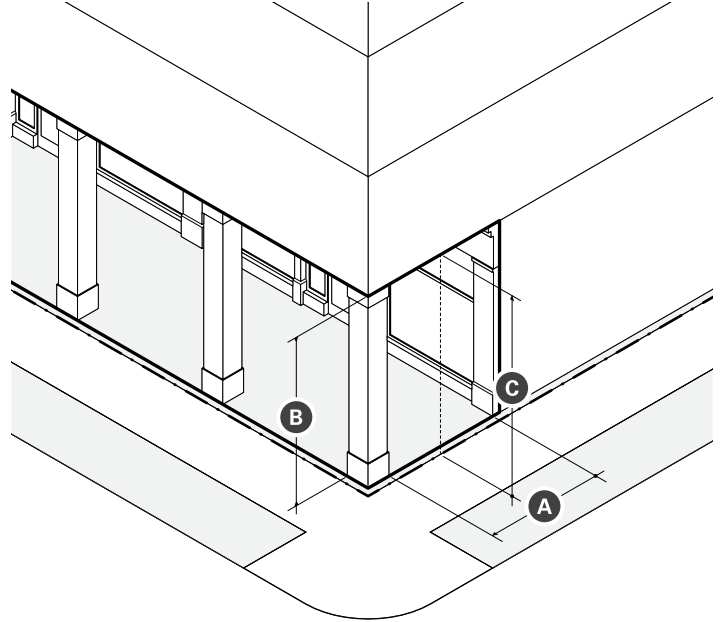

Dimensions		
A Depth (min/max)	10 ft	15 ft
B Height (max)	1 STORY	
C CLEARANCE (min/max)	14 ft	24 ft

- ii. Standards
 - a). Arcades must extend the entire width of a BUILDING and must have a consistent depth.
 - b). Support columns or PIERS may be spaced no farther apart than they are tall.
 - c). Arcades are considered part of the BUILDING for the purpose of measuring FACADE build out.
 - d). Arcades may be combined only with storefront and lobby entrance frontages.
 - e). The finished ceiling of an arcade interior may be arched or flat, but must have a greater CLEARANCE than the openings between columns OR PIERS.

4. MID-RISE DISTRICTS

Mid-Rise 5 (MR5)

11. Facade Design

- a. FACADES must provide solid material framing each storefront and lobby entrance as follows:
 - i. PILASTERS or columns supporting a horizontal lintel and CORNICE;
 - ii. a spandrel positioned between PILASTERS or columns that extend from upper stories of the building to the ground; or
 - iii. flat wall above and to either side of a void or punched opening.
- b. Storefronts and lobby entrances must be set within the resulting frame provided for each by the FACADE.
- c. Materials framing each storefront or lobby entrance may be integrated into the design of the FACADE or customized for individual storefronts and lobby entrances.
- d. Mechanical louvers necessary for venting purposes are not permitted in the required frame, but may be incorporated into any storefront or lobby entrance system.
- e. FACADES must differentiate the GROUND STORY of the building from the upper stories through horizontal ARTICULATION, a change in material, or a change in window size or pattern to create a distinct base to the building FACADE. The entire height of the GROUND STORY must be included in the FACADE base.
- f. Buildings of five (5) or more stories should include, at least, the entire height of the first two (2) stories in the required base. The design of the base may not shift up or down across the width of the FACADE.

- g. For buildings with more than one FACADE, the design of the base must align horizontally at the corner.
- h. FACADES must provide surface relief from the average plane of the FACADE by at least four (4) inches, through the USE of architectural elements such as bay windows, columns, CORNER BOARDS, CORNICES, door and window surrounds, moldings, PIERS, PILASTERS, recessed storefronts or lobby entrances, seat walls, sills, wall thickness, and recessed or projecting windows.
- i. The FACADE of any building greater than one hundred (100) feet in width must be designed as two (2) or more separate and distinct facades of differing architectural design so that the building appears to be multiple buildings. The facade designs must include a change in CORNICE, roof eave, or parapet design from one another.

12. Architectural Design Guidelines

- a. FACADES should be visually divided into a series of ARCHITECTURAL BAYS that are derived, in general, from the building's structural bay spacing.
- b. PIERS, PILASTERS, or other features defining each ARCHITECTURAL BAY should either extend all the way to the ground or terminate at any horizontal ARTICULATION defining the base of the building.
- c. ARCHITECTURAL BAYS should align, in general, with individual or groups of storefronts and lobby entrances.
- d. PIERS, PILASTERS, or other features defining each ARCHITECTURAL BAY should always project forward and be uninterrupted by any horizontal articulation, excluding

Figure 4.3.11 (a) Storefront & Lobby Entrance Framing

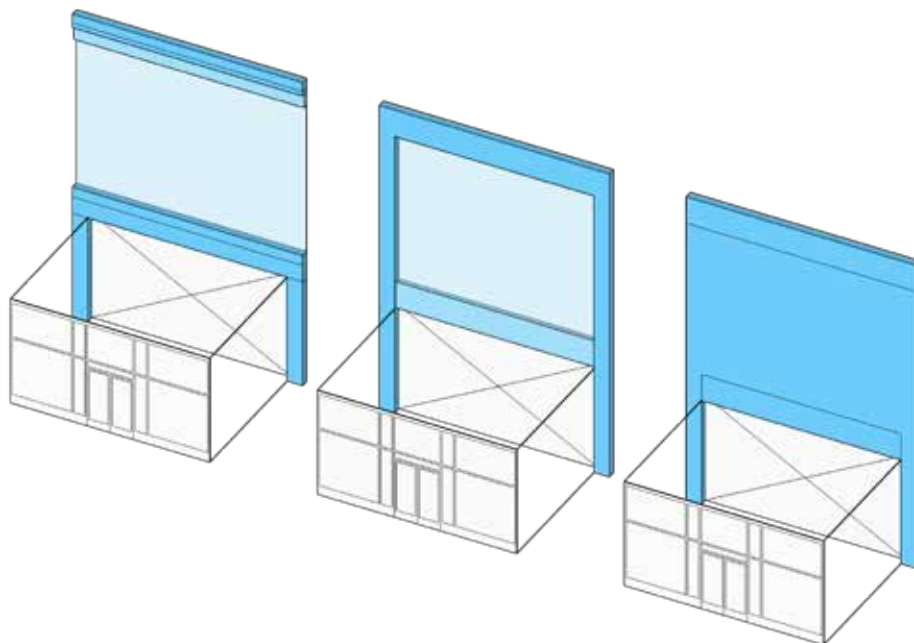

- any horizontal ARTICULATION USED to differentiate the base of the building.
- e. The FACADE of buildings with five (5) or more stories should be visually divided into, at least, a horizontal tripartite division (a base, middle, and top). The horizontal divisions may not shift up or down across the width of the FACADE.
 - f. Vents, exhausts, and other utility features on building FACADES should be architecturally integrated into the design of the building and should be located to minimize adverse effects on pedestrian comfort along sidewalks and within OPEN SPACES.
 - g. Buildings at TERMINATED VISTAS should be ARTICULATED with design features that function as focal points.
 - h. FENESTRATION glazing should be inset from the plane of exterior wall surfaces.
 - i. RIBBON WINDOWS should be avoided.
 - j. Monotonous and repetitive storefront or lobby systems, awnings, canopies, SIGN types, colors, or designs should be avoided.
 - k. Storefronts and lobby entrances should include awnings or canopies to provide weather protection for pedestrians and reduce glare for storefront display areas. Awnings should be open-ended and operable.
 - l. Lobby entrances for UPPER STORY USES should be optimally located, well defined, clearly visible, and separate from the entrance for other GROUND STORY USES.
 - m. Lobbies should be limited in both width and total area to preserve floor space and frontage for other GROUND STORY USES. Buildings should USE any combination of FACADE ARTICULATION, a double-height ceiling, a distinctive doorway, a change in wall material, a change in paving material within the FRONTAGE AREA, or some other architectural element(s) to make lobbies visual and materially distinctive.
 - n. The selection of materials, FENESTRATION, and ornamentation should result in a consistent and harmonious composition that appears as a unified whole rather than a collection of unrelated parts, no matter the style.
 - o. The type and color of materials should be kept to a minimum, preferably three (3) or fewer.
 - p. Two (2) or more wall materials should be combined only one above the other, except for bay windows.
 - q. Wall materials appearing heavier in weight should be used below wall materials appearing lighter in weight (wood and metal above brick, and all three above stone)
 - r. Horizontal or vertical board siding or shingles, regardless of material, should be avoided.
 - s. Architectural details and finish materials for the base of a building should be constructed of architectural concrete or pre-cast cementitious panels, natural or cast stone, heavy gauge metal panels, glazed or unglazed architectural terracotta, or brick.
 - t. Exterior Insulation and Finish Systems (EIFS) should be avoided.

Figure 4.3.11 (b) Appearance of Two Buildings



4. MID-RISE DISTRICTS

Mid-Rise 5 (MR5)

13. Use Provisions

- a. General
 - i. The USE of real property is subject to the provisions of Article 9: USE Provisions of this Ordinance. Where the provisions of this section conflict with those of Article 9, the provisions of Article 9 apply.
 - ii. USE categories are permitted as specified on Table 4.1 (c). USE categories not identified on Table 4.3.13 are prohibited.
 - iii. All USES must comply with any USE-specific standards applicable for each USE in §9.2 USE Definitions & Limitations.
 - iv. USES permitted by Special Permit require additional DEVELOPMENT review in accordance with §15.2.1 Special Permits.
- b. USE Limitations
 - i. The USE of any GROUND STORY commercial space fronting a PEDESTRIAN STREET, excluding lobbies for UPPER STORY USES, is limited to the following PRINCIPAL USE categories:
 - a). Arts & Creative Enterprise
 - b). Food & Beverage Service
 - c). Retail
 - d). Civic & Institutional
- c. Required USES
 - i. A minimum of five percent (5%) of the gross leasable commercial floor space in any BUILDING must be provided as LEASABLE FLOOR AREA for USES from the Arts & Creative Enterprise USE category.
- d. Increases in Density
 - i. Existing STRUCTURES may not be altered to conflict with number of DWELLING UNITS permitted for each BUILDING TYPE.

Table 4.3.13 Permitted Uses

Use Category Specific Use	MR5
Arts & Creative Enterprise	
Artisinal Production	P
Arts Exhibition	P
Arts Sales & Services	P
Co-working	P
Design Services	P
Shared Workspaces & Arts Education	P
Cannabis Establishment	
Cannabis Cultivation	P
Cannabis Retail Sales	SP
Cannabis Research & Development	P
Cannabis Testing Laboratory	P
Civic & Institutional	
Community Center	P
Hospital	SP
Library	P
Minor Utility Facility	SP
Museum	P
Private Non-Profit Club or Lodge	SP
Public Service	P
Religious & Educational Uses Protected by M.G.L. 40A. Sec. 3	P

P - Permitted SP - Special Permit Required N - Not Permitted

Table 4.3.13 Permitted Uses (continued)

Use Category Specific Use	MR5
Commercial Services	
Animal Services (as noted below)	--
Commercial Kennel	SP
Pet Grooming	P
Pet Daycare & Training	SP
Veterinarian	SP
Assembly or Entertainment	SP
Banking & Financial Services (except as noted below)	P
Personal Credit	SP
Broadcast and/or Recording Studio	P
Building & Home Repair Services	SP
Business Support Services	P
Caterer/Wholesale Food Production	SP
Day Care Service (as noted below)	--
Adult Day Care Center	P
Child Day Care Center	P
Educational Services	P
Maintenance & Repair of Consumer Goods	P
Personal Services (except as noted below)	P
Body-Art Services	SP
Fitness Services	P
Funeral Services	SP
Health Care Services	SP
Formula Personal Services	SP
Recreation Services	SP
Vehicle Parking (except as follows)	--
Bike Share Parking	P
Car Share Parking (3 or fewer spaces)	P
Car Share Parking (4 or more spaces)	P
Commercial Parking	P
Food and Beverage Service	
Bar/Restaurant/Tavern	P
Bakery/Café/Coffee Shop	P
Formula Food & Beverage Service	SP

P - Permitted SP - Special Permit Required N - Not Permitted

Table 4.3.13 Permitted Uses (continued)

Use Category Specific Use	MR5
Lodging	
Bed & Breakfast	SP
Hotel or Hostel	SP
Office	
General Office	P
Research and Development and/or Laboratory	P
Residential	
Household Living	SP
Group Living (except as follows)	SP
Community or Group Residence	P
Dormitory, Fraternity or Sorority	SP
Homeless Shelter	SP
Nursing Home/Assisted Living Facility	SP
Rooming House	SP
Retail Sales	
Building/Home Supplies & Equipment	SP
Consumer Goods (except as follows)	P
Alcohol Sales	SP
Firearms Sales	N
Pet Store	SP
Formula Retail	SP
Fresh Food Market or Grocery Store	P
Farm/Vendor Market	P
Urban Agriculture	
Farming (as noted below)	--
Commercial Farming	P
Community Farming	P
Community Gardening	P

P - Permitted SP - Special Permit Required N - Not Permitted

4. MID-RISE DISTRICTS

Mid-Rise 5 (MR5)

Table 4.3.13 Permitted Uses (continued)

Use Category Specific Use	MR5
Accessory Uses	
Home Occupations (as noted below)	--
Home Office	P
Urban Agriculture (as noted below)	--
Apiculture	P
Aviculture	P
Commercial Farming	P
Residential Gardening	P
Vehicle Parking, Accessory	P
Home Business Vehicle Parking	N

P - Permitted SP - Special Permit Required N - Not Permitted

14. Development Standards

- a. General
 - i. DEVELOPMENT is subject to the provisions of Article 10: DEVELOPMENT STANDARDS of this Ordinance. Where the provisions of this section conflict with those of Article 10, the provisions of Article 10 apply.
- b. SIGNS
 - i. A SIGN, individual numerals or letters, or a nonelectrical nameplate identifying the property address is required for all real property as follows:
 - a). Each GROUND STORY non-residential USE must identify the STREET address either on the PRINCIPAL ENTRANCE door or above or beside the PRINCIPAL ENTRANCE of the USE.
 - b). All residential BUILDING TYPES must identify the STREET address either on the PRINCIPAL ENTRANCE door, above or beside the PRINCIPAL ENTRANCE, or on a mailbox.
 - ii. Address SIGNS must be made easily visible through the USE of colors or materials that contrast with the background material they are attached to and must be conspicuously located to provide visibility from the THOROUGHFARE that the BUILDING faces.
 - iii. Address SIGNS must be twelve (12) inches in height or less and may include the name of the occupant.

15. Parking & Mobility

- a. General
 - i. DEVELOPMENT is subject to the provisions of Article 11: Parking & Mobility of this Ordinance. Where the provisions of this section conflict with those of Article 11, the provisions of Article 11 apply.
 - ii. Vehicular parking must be provided as specified on Table 4.1 (d), except as follows:
 - a). Non-residential USES with five thousand (5,000) square feet or less of GROSS LEASABLE FLOOR AREA are exempt from any minimum requirements of Table 4.1. (d).
 - b). Any CHANGE IN USE within a non-residential STRUCTURE constructed before the effective date of this Ordinance, provided that the change is to a permitted USE, is exempt from any minimum requirements of Table 4.1 (d).
 - iii. There are no parking requirements for ACCESSORY USES.
 - iv. MOTOR VEHICLE PARKING spaces may be shared between USES on the same LOT and buildings on the same BLOCK in accordance with §11.3 SHARED PARKING.
- b. Type
 - i. MOTOR VEHICLE PARKING may be provided as above ground STRUCTURED PARKING or underground STRUCTURED PARKING. SURFACE PARKING is prohibited.
- c. Driveways
 - i. New driveways require a permit from the City Engineer.
 - ii. Driveways must be compliant with all City Ordinances and constructed in accordance with all standards established by relevant City Departments.
 - iii. Driveways are not permitted in the FRONTAGE AREA between a BUILDING and the FRONT LOT LINE.
 - iv. Driveways may be no wider than twenty four (24) feet in the FRONTAGE AREA of a LOT.
 - v. Driveways may provide ACCESS in whole or in part on or across an ABUTTING LOT(s), provided that an ACCESS EASEMENT exists between all PROPERTY OWNERS.
- d. Parking Design
 - i. The design of all parking is subject to §11.1 Bicycle Parking and §11.2 MOTOR VEHICLE PARKING of this Ordinance.
- e. Parking Location
 - i. Required vehicular parking, excluding any required handicapped parking, may be provided on a contiguous LOT under the same ownership as the LOT that the parking will serve as follows:
 - a). Pedestrian ACCESS to off-SITE vehicular parking must be via a paved sidewalk or walkway.
 - b). A lease, recorded covenant, or other comparable legal instrument guaranteeing long term USE of the SITE must be provided to the review board or BUILDING OFFICIAL and executed and filed with the Registry of Deeds.
 - ii. For real property located in more than one municipality, MOTOR VEHICLE PARKING need not be located within the City of Somerville.
- f. Unbundled Parking
 - i. MOTOR VEHICLE PARKING spaces must be rented or leased as an option rather than a requirement of the rental, lease, or purchase of a DWELLING UNIT or non-residential floor space.
 - ii. Bicycle parking must be provided at no cost or fee to customers, visitors, employees, tenants, and residents.
- g. Parking Relief
 - i. Relief from the parking standards of Table 4.3 (d) requires a Special Permit.
 - a). In addition to the review criteria for all Special Permits specified in §15.2.1.e. Review Criteria, the review board shall make findings considering the following in its discretion to approve or deny a special permit authorizing relief from the parking standards of Table 4.3 (d):
 - i). The supply and demand of on-STREET parking in the neighborhood, as determined through a parking study.
 - ii). MOBILITY MANAGEMENT programs and services provided by the APPLICANT to reduce the demand for parking.
 - iii). That parking provided in excess of any maximum permitted does not result in the increase in impervious LOT AREA.

16. PUBLIC REALM

- a. Sidewalks
 - i. When DEVELOPMENT OCCURS on any LOT ABUTTING a sidewalk that is less than twelve (12) feet in total width, the BUILDING must be set-back an additional distance to accommodate expansion of the ABUTTING sidewalk to a width of at least twelve (12) feet. The minimum and maximum front SETBACKS for each BUILDING TYPE are increased accordingly.
- b. Sidewalk CURB CUTS
 - i. A CURB CUT requires a permit from the City Engineer and must be compliant with all City Ordinances.
 - ii. Unless otherwise specified, the City Engineer may not permit more than one (1) CURB CUT per FRONT LOT LINE of a LOT.
 - iii. CURB CUTS are prohibited along all THOROUGHFARES designated as a PEDESTRIAN STREET.
 - iv. CURB CUTS must be located to minimize conflicts with pedestrians and bicyclists and must have a clear distance from fire hydrants, STREET TREES, utility

4. MID-RISE DISTRICTS

Mid-Rise 5 (MR5)

Table 4.3.15 Vehicular Parking

Use Category Specific Use	BICYCLE		MOTOR VEHICLE	
	Short-Term (min)	Long-Term (min)	Within a TRANSIT AREA ¹ (max)	Outside of a TRANSIT AREA ¹ (min)
Arts & Creative Enterprise				
All Permitted Uses	1 / 10,000 sf	1 / 3,000 sf	1 / 800 sf	1 / 1,000 sf
Cannabis Establishment				
Cannabis Retail Sales	1 / 2,500 sf	1 / 10,000 sf	1 / 1,500 sf	1 / 750 sf
Cannabis Research & Development	1 / 20,000 sf	1 / 5,000 sf	1 / 1,000 sf	1 / 1,000 sf
Cannabis Testing Laboratory	1 / 20,000 sf	1 / 5,000 sf	1 / 1,000 sf	1 / 1,000 sf
Civic & Institutional				
COMMUNITY CENTER	1 / 10,000 sf	4 / 10,000 sf	1 / 1,800 sf	1 / 600 sf
Educational Facility	1.0 / classroom	4.0 / classroom	1.5 / classroom	3.0 / classroom
HOSPITAL	10 per entrance	1 / 5,000 sf	1 / 200 sf	1 / 1,000 sf
LIBRARY	1 / 3,000 sf	1 / 5,000 sf	1 / 800 sf	1 / 500 sf
MINOR UTILITY FACILITY	n/a	n/a	n/a	n/a
MUSEUM	1 / 2,000 sf	1 / 10,000 sf	1 / 800 sf	1 / 500 sf
Private Non-Profit Club or Lodge	1 / 2,000 sf	1 / 10,000 sf	1 / 200 sf	1 / 1,000 sf
Commercial Services				
Animal Services (as noted below)	–	–	–	–
Commercial Kennel	1 / 2,500 sf	1 / 10,000 sf	1 / 500 sf	1 / 500 sf
Pet Grooming	1 / 2,500 sf	none	1 / 500 sf	1 / 500 sf
Pet Day Care or Training	1 / 2,500 sf	none	1 / 500 sf	1 / 500 sf
Veterinarian	1 / 2,500 sf	1 / 5,000 sf	1 / 500 sf	1 / 500 sf
ASSEMBLY OR ENTERTAINMENT	1 / 40 seats	1 / 10,000 sf	1 / 6 seats	1 / 6 seats
Banking & Financial Services (except as noted below)	1 / 2,000 sf	1 / 10,000 sf	1 / 450 sf	1 / 400 sf
Broadcast and/or Recording Studio	1 / 2,500 sf	1 / 10,000 sf	1 / 800 sf	1 / 600 sf
BUILDING & Home Repair Services	1 / 2,500 sf	1 / 10,000 sf	1 / 1,000 sf	1 / 2,000 sf
BUSINESS SUPPORT SERVICES	1 / 2,500 sf	1 / 10,000 sf	1 / 900 sf	1 / 600 sf
Caterer/Wholesale Food Production	1 / 2,500 sf	1 / 10,000 sf	1 / 800 sf	1 / 1,000 sf
Day Care Service	2	1 / 10,000 sf	1 / 900 sf	1 / 600 sf
Maintenance & Repair of CONSUMER GOODS	1 / 2,500 sf	1 / 10,000 sf	1 / 750 sf	1 / 1,000 sf
PERSONAL SERVICES (except as noted below)	1 / 2,500 sf	1 / 10,000 sf	1 / 750 sf	1 / 1,000 sf
Health Care Services	1 / 2,000 sf	1 / 10,000 sf	1 / 500 sf	1 / 300 sf
Recreation Services	1 / 2,500 sf	1 / 10,000 sf	–	–

sf - Gross Leasable Square Footage

DU - DWELLING UNIT

RU - ROOMING UNIT

¹ See the TRANSIT AREA Map

Table 4.3.15 Vehicular Parking (continued)

Use Category Specific Use	BICYCLE		MOTOR VEHICLE	
	Short-Term (min)	Long-Term (min)	Within a TRANSIT AREA ¹ (max)	Outside of a TRANSIT AREA ¹ (min)
Food and Beverage Service				
All Permitted Uses	1 / 1,000 sf	1 / 5,000 sf	1 / 300 sf	1 / 500 sf
Lodging				
BED & BREAKFAST	n/a	2.0	1 / DU + 1 / 4 guest rooms	1 / DU + 1 / 4 guest rooms
HOTEL OR HOSTEL	1 / 20 rooms	1 / 10 rooms	1 / 2 guest rooms	1 / 2 guest rooms
Office				
Co-WORKING	1 / 20,000 sf	1 / 3,000 sf	1 / 1,200 sf	1 / 800 sf
GENERAL OFFICE	1 / 20,000 sf	1 / 3,000 sf	1 / 900 sf	1 / 650 sf
Research and Development and/or Laboratory	1 / 20,000 sf	1 / 5,000 sf	1 / 1,000 sf	1 / 1,000 sf
Residential				
HOUSEHOLD LIVING	0.1 / DU	1.0 / DU	1.0 / DU	1.0 / DU
GROUP LIVING (except as follows)	0.05 / room	0.5 / room	--	--
COMMUNITY OR GROUP RESIDENCE	--	--	--	--
Dormitory, Fraternity or Sorority	0.1 / room	0.5 / room	.05 / bed	1.0 / 4 beds
HOMELESS SHELTER	--	--	4.0	4.0
Nursing Home/Assisted Living Facility	--	--	1 / 6 beds	1 / 6 beds
Single Room Occupancy Housing	--	--	1 / 6 beds	1 / 4 beds
Retail Sales				
BUILDING/Home Supplies & Equipment	1 / 2,500 sf	1 / 10,000 sf	1 / 1,000 sf	1 / 1,000 sf
CONSUMER GOODS (except as follows)	1 / 2,500 sf	1 / 10,000 sf	1 / 1,500 sf	1 / 750 sf
FORMULA RETAIL	1 / 2,500 sf	1 / 10,000 sf	1 / 1,500 sf	1 / 750 sf
FRESH FOOD MARKET OR GROCERY STORE	1 / 1,000 sf	1 / 10,000 sf	1 / 500 sf	1 / 1,500 sf
Farm/Vendor Market	n/a	n/a	n/a	1 / 1,500 sf

sf - Gross Leasable Square Footage

DU - DWELLING UNIT

RU - ROOMING UNIT

¹ See the TRANSIT AREA Map

4. MID-RISE DISTRICTS

Mid-Rise 5 (MR5)

poles, and other furnishings as deemed necessary by the City Engineer.

- a). CURB CUTS for commercial or high-volume driveways should be at least one-hundred (100) feet from an UNSIGNALIZED or SIGNALIZED intersection.
- b). CURB CUTS for residential driveways should be at least twenty (20) feet from an UNSIGNALIZED intersection and at least forty (40) feet from a SIGNALIZED intersection.
- v. The interior width of a CURB CUT (between curb stones) may be no wider than the driveway, vehicular entrance, or loading facility it serves.
- vi. A DRIVEWAY APRON may be installed only within the furnishing zone of a sidewalk and must be constructed in accordance with all standards established by relevant City Departments.
- vii. The grade, cross slope, and clear width of the walkway of a sidewalk must be maintained between the DRIVEWAY APRON and the ABUTTING driveway. The appearance of the walkway (ie. scoring pattern or paving material) must indicate that, although a vehicle may cross, the area traversed by a vehicle remains part of the sidewalk.

Figure 4.3.16 Sidewalk Curb Cuts

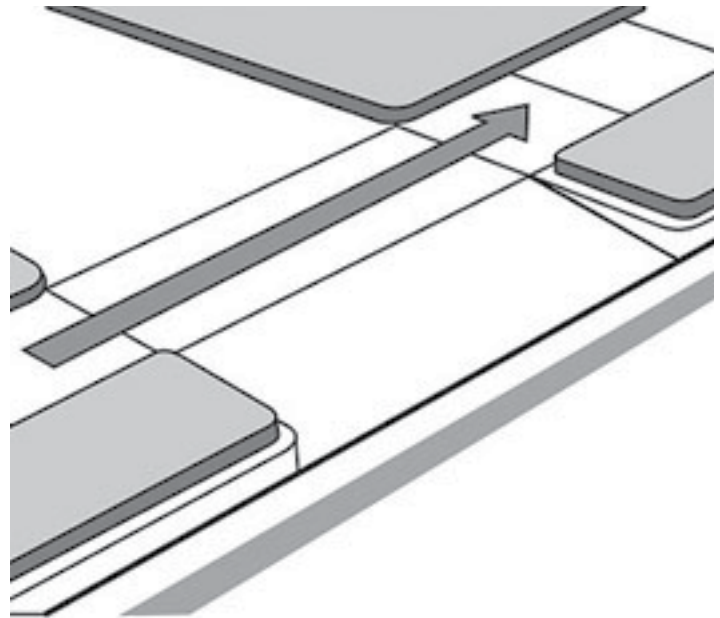

4.4 MID-RISE 6 (MR6)

1. Character Description

The Mid-Rise 6 district is characterized by a variety of moderate to large FLOOR PLATE buildings up to six (6) stories in height. Buildings are set close to the sidewalk to create a defined STREET wall that supports pedestrian activity and a sense of place. The district is primarily commercial, with a variety of employment opportunities and GROUND STORY USES that address the needs of residents and employees from the immediate neighborhood, but can also provide goods and services to the larger Somerville community and visitors from the broader Boston metropolitan area.

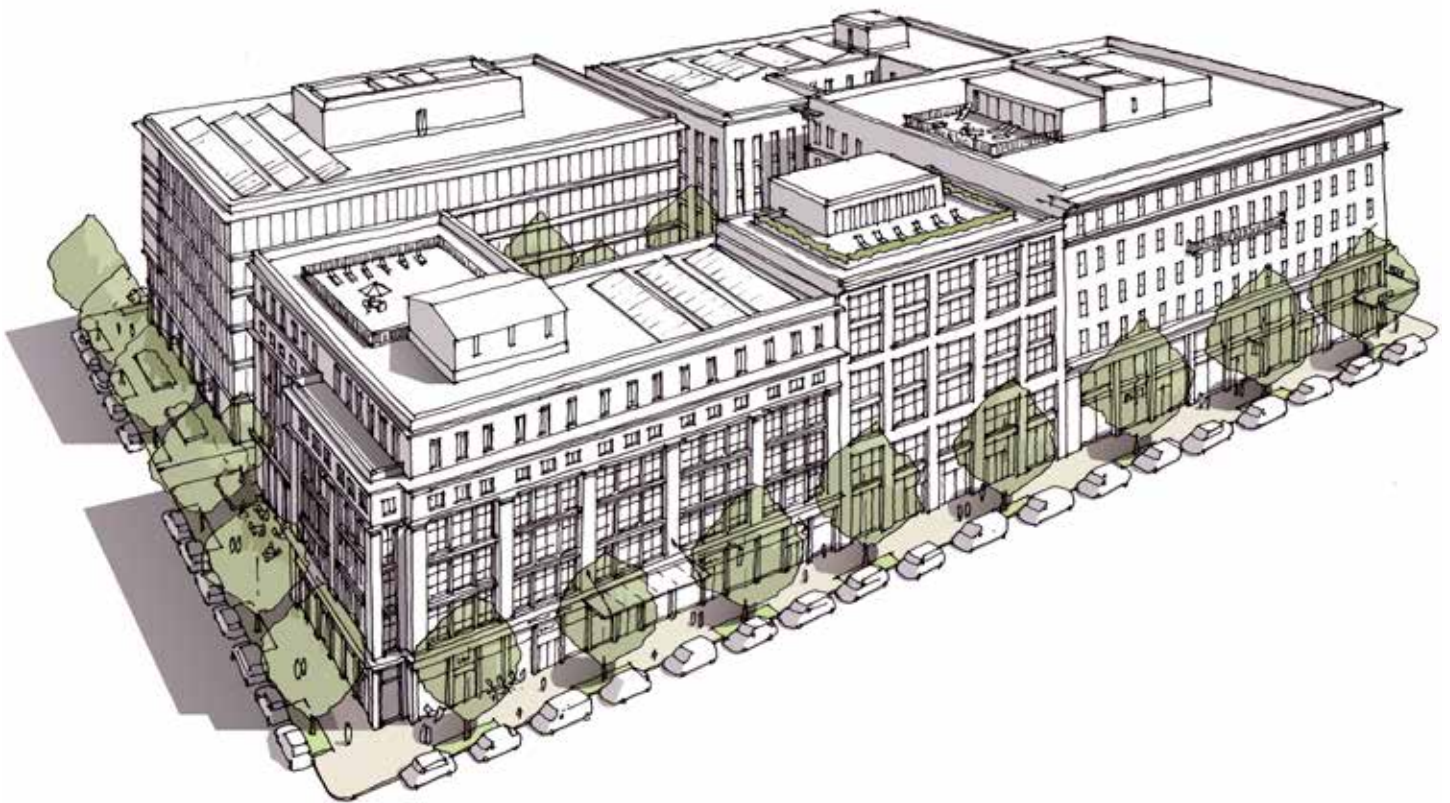

4. MID-RISE DISTRICTS

Mid-Rise 6 (MR6)

2. Intent

- a. To implement the objectives of the COMPREHENSIVE PLAN of the City of Somerville.
- b. To accommodate the DEVELOPMENT of areas appropriate for moderately-scaled multi-unit, mixed-USE, and commercial buildings; neighborhood-, community-, and region-serving USES; and a wide variety of employment opportunities.

3. Purpose

- a. To permit the DEVELOPMENT of multi-unit, mixed-USE, and commercial buildings that do not exceed six (6) stories in height.
- b. To provide quality commercial spaces and permit small and medium-scale, neighborhood-, community-, and region-serving commercial USES.
- c. To create DWELLING UNIT types, sizes, and BEDROOM counts ideal for larger households in apartment buildings.
- d. To create DWELLING UNIT types, sizes, and BEDROOM counts ideal for smaller households in general buildings.
- e. To permit increased residential density for buildings that are sustainable or that provide 100% AFFORDABLE HOUSING.
- f. To permit increased residential density for buildings that meet the definition of a NET ZERO BUILDING or 100% AFFORDABLE HOUSING.

4. Applicability

- a. The section is applicable to all real property within the Mid-Rise 6 district as shown on the maps of the Official Zoning Atlas of the City of Somerville.

5. Development Review

- a. DEVELOPMENT review is subject to the provisions of Article 15: Administration of this Ordinance.
- b. All DEVELOPMENT, excluding NORMAL MAINTENANCE, requires the submittal of a development review application to the BUILDING OFFICIAL and the issuance of a Certificate of Zoning Compliance prior to the issuance of a BUILDING Permit or Certificate of Occupancy.
- c. Proposed DEVELOPMENT may or may not necessitate the need for SUBDIVISION Plan Approval, Site Plan Approval, a Special Permit, or a Hardship Variance based on the nature of the proposal. In such cases, additional DEVELOPMENT review is required in accordance with Article 15: Administration.
 - i. The Planning Board is the decision making authority for all DEVELOPMENT that requires Site Plan Approval or a Special Permit.
 - ii. The Zoning Board of Appeals is the Review Board for all HardSHIP Variances.
- d. Upon verification that no additional DEVELOPMENT review is necessary, or completion of the required DEVELOPMENT review, the BUILDING OFFICIAL shall issue a Zoning

Compliance CERTIFICATE to certify compliance with the provisions and procedures of this Ordinance.

6. Building Types

- a. One (1) PRINCIPAL BUILDING TYPE is permitted on each LOT.
- b. The following BUILDING TYPES are permitted by Site Plan Approval in the Mid-Rise 6 district:
 - i. Apartment BUILDING
 - ii. General BUILDING
 - iii. Commercial BUILDING
 - iv. Lab BUILDING
- c. Apartment Buildings are prohibited on any LOT fronting a PEDESTRIAN STREET.
- d. ACCESSORY STRUCTURES are regulated according to Article 10: DEVELOPMENT Standards of this Ordinance.

4.4.7 Apartment Building

A large FLOOR PLATE, multi-STORY PRINCIPAL BUILDING TYPE purpose built for OCCUPATION by residential USES on all stories.

The following images are examples of the apartment BUILDING TYPE and are intended only for illustrative purposes.



4. MID-RISE DISTRICTS

Mid-Rise 6 (MR6)

4.4.7. Apartment Building (continued)

a. LOT Standards

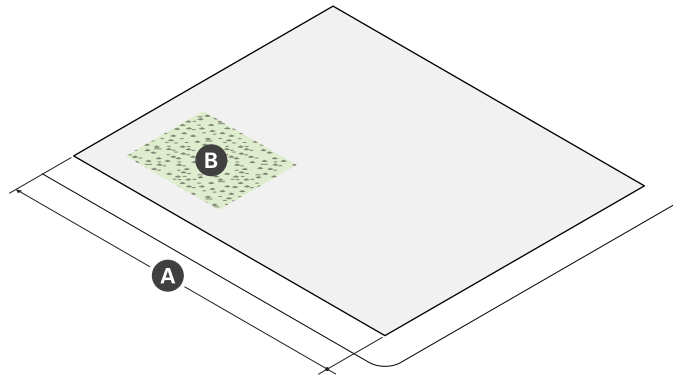

Lot Dimensions	
A LOT WIDTH (min)	30 ft

Lot Development	
LOT Coverage (max)	100%
GREEN SCORE	--
Minimum	0.20
Ideal	0.25
B OPEN SPACE (min)	15%

b. BUILDING Placement

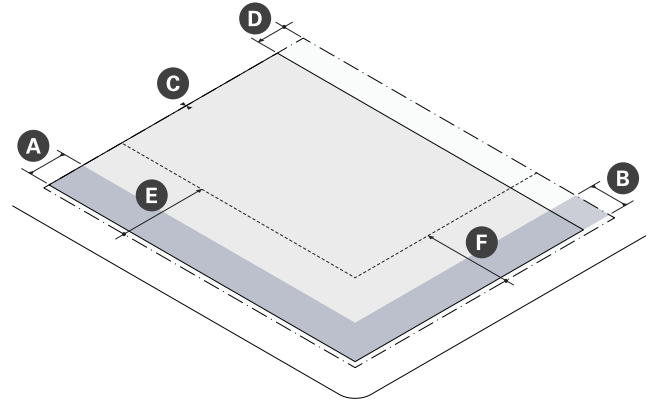

Building Setbacks		
A Primary Front SETBACK (min/max)	2 ft	12 ft
B Secondary Front SETBACK (min/max)	2 ft	12 ft
C Side SETBACK (min)	0 ft	
Side SETBACK ABUTTING NR or LHD (min)	10 ft	
D Rear SETBACK (min)	--	
ALLEY	0 ft	
No ALLEY	10 ft	
No ALLEY & ABUTTING NR or LHD	15 ft	

Parking Setbacks	
E Primary Front SETBACK (min)	--
SURFACE PARKING	30 ft
STRUCTURED PARKING	30 ft
F Secondary Front SETBACK (min)	--
SURFACE PARKING	10 ft
STRUCTURED PARKING	2 ft

4.4.7. Apartment Building (continued)

c. Massing & Height

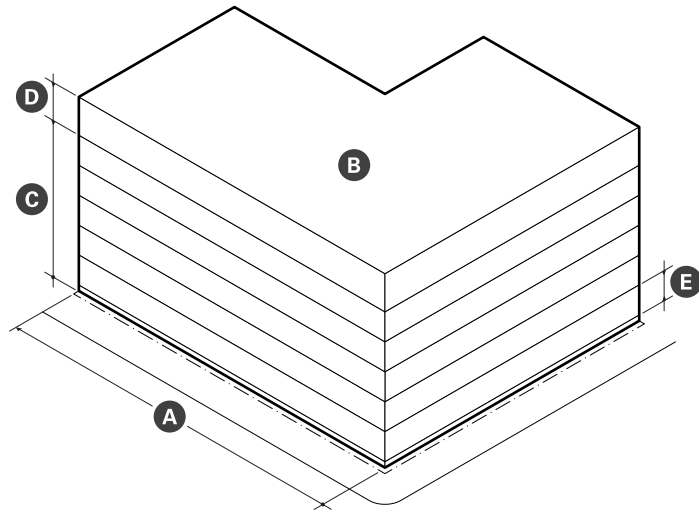

Main Massing	
A BUILDING WIDTH (max)	200 ft
FACADE Build Out	--
Primary Front	80%
Secondary Front	65%
B FLOOR PLATE (max)	25,000 sf
GROUND STORY Elevation (min)	2 ft
E STORY Height (min)	10 ft
C Number of Stories (min/max)	3 6
D UPPER STORY STEP-BACK (min)	--
Primary/Secondary Front	10 ft
Side/Rear ABUTTING NR	30 ft
E BUILDING Height, Feet	70 ft
Roof Type	Flat

d. Uses & Features

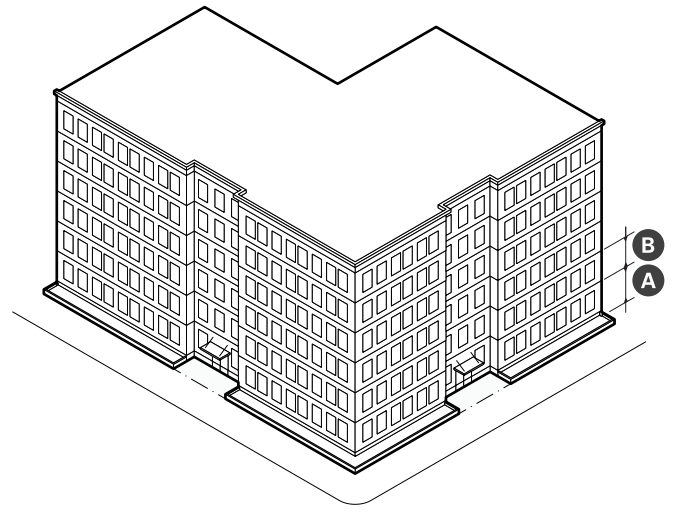

Facade Composition	
A GROUND STORY FENESTRATION (min/max)	20% 50%
B UPPER STORY FENESTRATION (min/max)	20% 50%
BLANK WALL (max)	20 ft

Use & Occupancy	
GROSS FLOOR AREA per DU	--
LOT AREA < 6,500 sf	1,125
LOT AREA >= 6,500 sf	850
NET ZERO BUILDING	650
100% AFFORDABLE HOUSING	650
Outdoor AMENITY SPACE (min)	1/DU

4. MID-RISE DISTRICTS

Mid-Rise 6 (MR6)

4.4.7. Apartment Building (continued)

- e. DEVELOPMENT Benefits
 - i. DEVELOPMENT is subject to the provisions of Article 12: DEVELOPMENT Benefits of this Ordinance. Where the provisions of this section conflict with those of Article 12, the provisions of Article 12 apply.
 - ii. DEVELOPMENT of a general building must provide AFFORDABLE DWELLING UNITS as specified on Table 4.4.7 (a).
- f. Design Guidelines
 - i. GROUND STORY DWELLING UNITS should be elevated above the grade of any adjacent sidewalk so that the window sills of the DWELLING UNIT are at or above the eye-level of passing pedestrians. This elevation change maintains privacy for occupants while also encouraging open blinds or curtains to allow natural daylight into the unit.
 - ii. FENESTRATION patterns and window configurations should break the direct line of sight between neighboring properties to every extent practicable. Translucent glass on the bottom half of windows or strategically placed landscape elements should be utilized if it is not practical to off-set windows in such a way as to minimize privacy impacts.
 - iii. Outdoor AMENITY SPACES that are elevated, such as roof DECKS, fully projecting balconies, and UPPER STORY rear porches should, provide sight-obscuring visual screening at the sides to increase privacy, security, and to limit views of ABUTTING properties from elevated vantage points.

Table 4.4.7 Required ADUs

Total DWELLING UNITS	Required ADUs
0 to 5 units	None
6 units	1 unit OR fractional buyout for 0.4 units
7 units	1 unit OR fractional buyout for 0.6 units
8 to 17 units	17.5% of units
18 or more units	20% of units

4.4.8 General Building

A large FLOOR PLATE, multi-STORY PRINCIPAL BUILDING TYPE with GROUND STORY commercial space and no limitations on the occupancy of UPPER STORIES for permitted USES. The UPPER STORIES of a general BUILDING are typically residential, but a wide variety exists. As the number of stories increases, it becomes more likely for the UPPER STORIES of a general BUILDING to host commercial USES as well as residential.

The following images are examples of the general BUILDING TYPE and are intended only for illustrative purposes.



4. MID-RISE DISTRICTS

Mid-Rise 6 (MR6)

4.4.8. General Building (continued)

a. Lot Standards

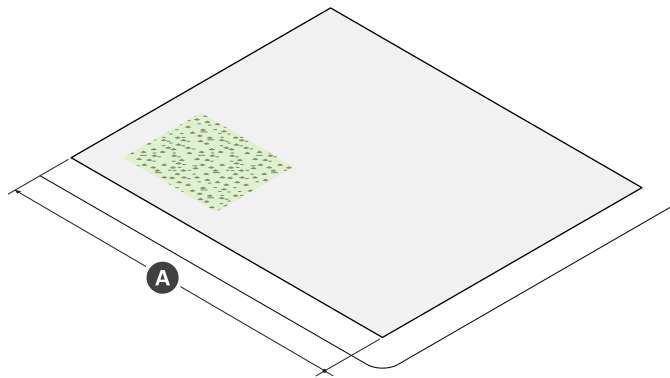

Lot Dimensions	
A LOT WIDTH (min)	30 ft

Lot Development	
LOT Coverage (max)	100%
GREEN SCORE	--
Minimum	0.20
Ideal	0.25
B OPEN SPACE (min)	15%

b. BUILDING Placement

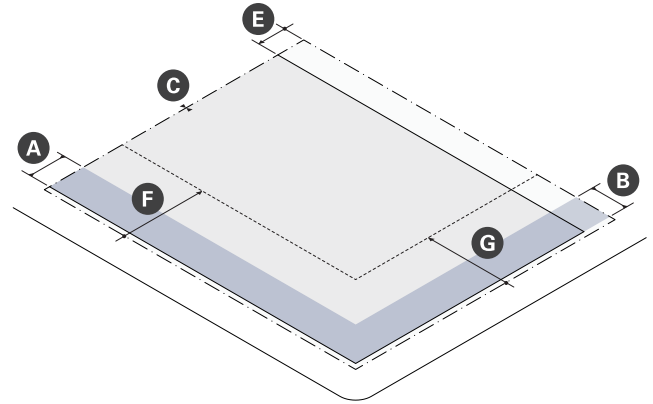

Building Setbacks		
A Primary Front SETBACK (min/max)	2 ft	15 ft
B Secondary Front SETBACK (min/max)	2 ft	15 ft
C Side SETBACK (min)	0 ft	
Side SETBACK ABUTTING NR or LHD (min)	10 ft	
D Rear SETBACK (min)	--	
ALLEY	0 ft	
No ALLEY	10 ft	
No ALLEY & ABUTTING NR or LHD	15 ft	

Parking Setbacks	
E Primary Front SETBACK (min)	--
SURFACE PARKING	30 ft
STRUCTURED PARKING	30 ft
F Secondary Front SETBACK (min)	--
SURFACE PARKING	10 ft
STRUCTURED PARKING	2 ft

4.4.8. General Building (continued)

c. Massing & Height

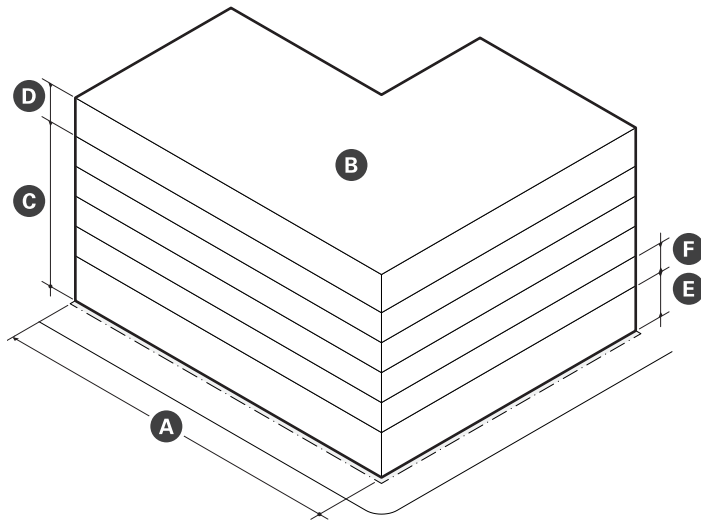

d. Uses & Features

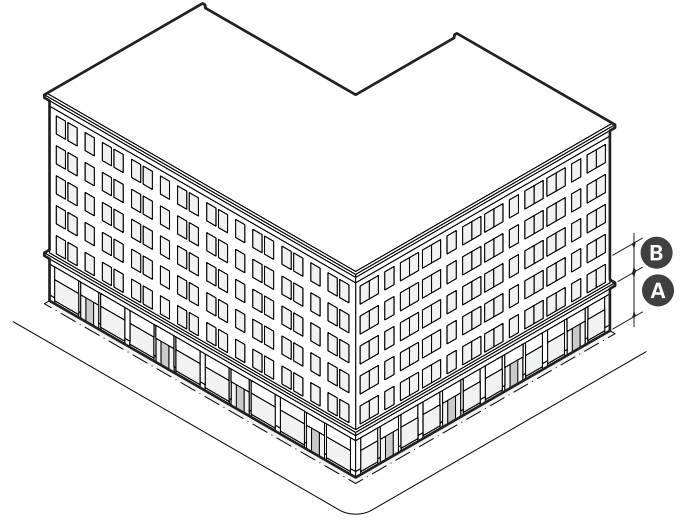

Main Massing	
A BUILDING WIDTH (max)	200 ft
FACADE Build Out (min)	--
Primary Front	80%
Secondary Front	65%
B FLOOR PLATE (max)	30,000 sf
C GROUND STORY Height	14 ft
D UPPER STORY Height	10 ft
E Number of Stories (min/max)	3 6
F UPPER STORY STEP-BACK (min)	--
Primary/Secondary Front	10 ft
Side/Rear ABUTTING NR	30 ft
G BUILDING Height, Feet (max)	75 ft
Roof Type	Flat

Facade Composition	
A GROUND STORY FENESTRATION (min)	70%
B UPPER STORY FENESTRATION (min/max)	20% 50%
BLANK WALL (max)	20 ft

Use & Occupancy	
GROUND STORY Entrance Spacing (max)	30 ft
Commercial Space Depth (min)	30 ft
GROSS FLOOR AREA per DU	--
LOT AREA < 6,500 sf	1,125
LOT AREA >= 6,500 sf	850
NET ZERO BUILDING	650
100% AFFORDABLE HOUSING	650
Outdoor AMENITY SPACE (min)	1/DU

4. MID-RISE DISTRICTS

Mid-Rise 6 (MR6)

4.4.8. General Building (continued)

- e. DEVELOPMENT Benefits
 - i. DEVELOPMENT is subject to the provisions of Article 12: DEVELOPMENT Benefits of this Ordinance. Where the provisions of this section conflict with those of Article 12, the provisions of Article 12 apply.
 - ii. DEVELOPMENT of a general building must provide AFFORDABLE DWELLING UNITS as specified on Table 4.4.8 (a).
 - iii. DEVELOPMENT of a general building must provide linkage payments as specified on Table 4.4.8 (b).
- f. Design Guidelines
 - i. FENESTRATION patterns and window configurations should break the direct line of sight between neighboring properties to every extent practicable. Translucent glass on the bottom half of windows or strategically placed landscape elements should be utilized if it is not practical to off-set windows in such a way as to minimize privacy impacts.
 - ii. Outdoor AMENITY SPACES that are elevated, such as roof DECKS, fully projecting balconies, and UPPER STORY rear porches should, provide sight-obscuring visual screening at the sides to increase privacy, security, and to limit views of ABUTTING properties from elevated vantage points.

Table 4.4.8 (a) Required ADUs

Total DWELLING UNITS	Required ADUs
0 to 5 units	None
6 units	1 unit OR fractional buyout for 0.4 units
7 units	1 unit OR fractional buyout for 0.6 units
8 to 17 units	17.5% of units
18 or more units	20% of units

Table 4.4.8 (b) Linkage

Commercial GROSS FLOOR AREA	Affordable Housing Linkage	Employment Linkage
30,000 sf or less	None	None
Over 30,000 sf	\$10/sf	\$2.46/sf

4.4.9 Commercial Building

A large FLOOR PLATE, multi-STORY PRINCIPAL BUILDING TYPE purpose built for OCCUPATION by commercial USES on all stories. GROUND STORY commercial space is primarily occupied by commercial service, food & beverage service, or retail sales PRINCIPAL USES. Floor space on upper stories may be occupied by retail USES that do not rely on the visibility of a storefront at sidewalk level.

The following images are examples of the commercial BUILDING TYPE and are intended only for illustrative purposes.



4. MID-RISE DISTRICTS

Mid-Rise 6 (MR6)

4.4.9. Commercial Building (continued)

a. Lot Standards

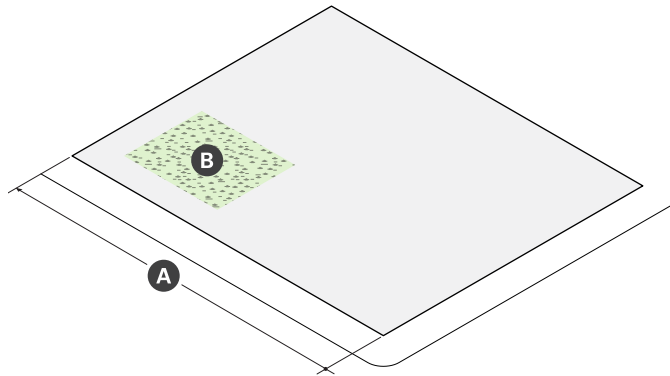

Lot Dimensions	
A LOT WIDTH (min)	30 ft

Lot Development	
LOT Coverage (max)	100%
GREEN SCORE	--
Minimum	0.20
Ideal	0.25
B OPEN SPACE (min)	15%

b. BUILDING Placement

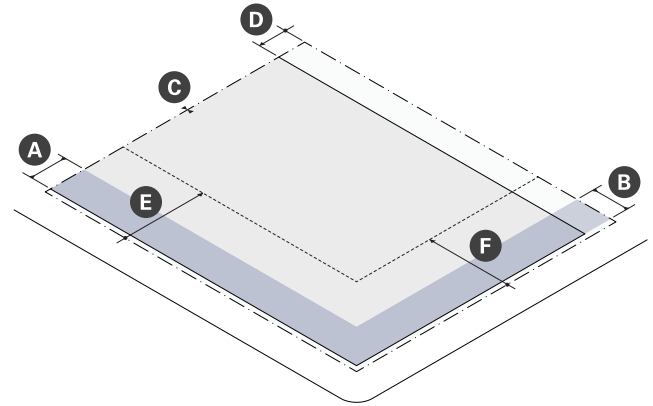

Building Setbacks		
A Primary Front SETBACK (min/max)	2 ft	15 ft
B Secondary Front SETBACK (min/max)	2 ft	15 ft
C Side SETBACK (min)	0 ft	
Side SETBACK ABUTTING NR or LHD (min)	10 ft	
D Rear SETBACK (min)	--	
ALLEY	0 ft	
No ALLEY	10 ft	
No ALLEY & ABUTTING NR or LHD	15 ft	

Parking Setbacks	
E Primary Front SETBACK (min)	--
SURFACE PARKING	30 ft
STRUCTURED PARKING	30 ft
F Secondary Front SETBACK (min)	--
SURFACE PARKING	10 ft
STRUCTURED PARKING	2 ft

4.4.9. Commercial Building (continued)

c. Massing & Height

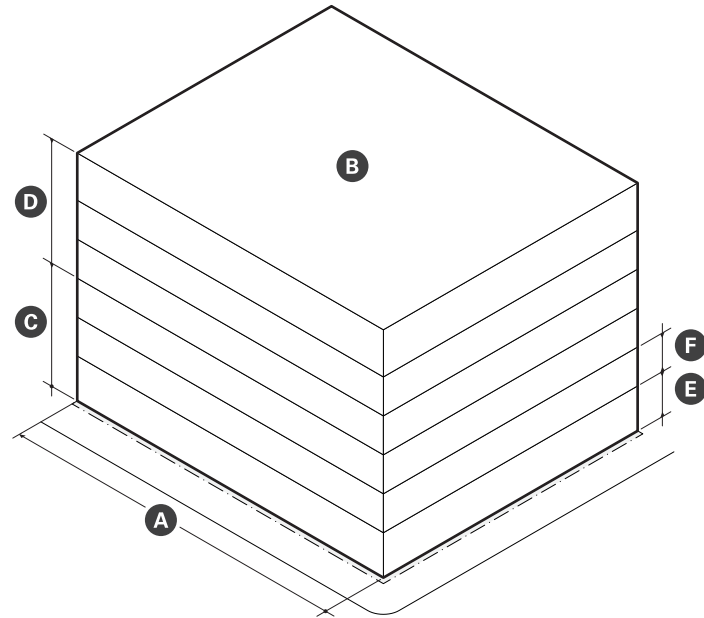

d. Uses & Features

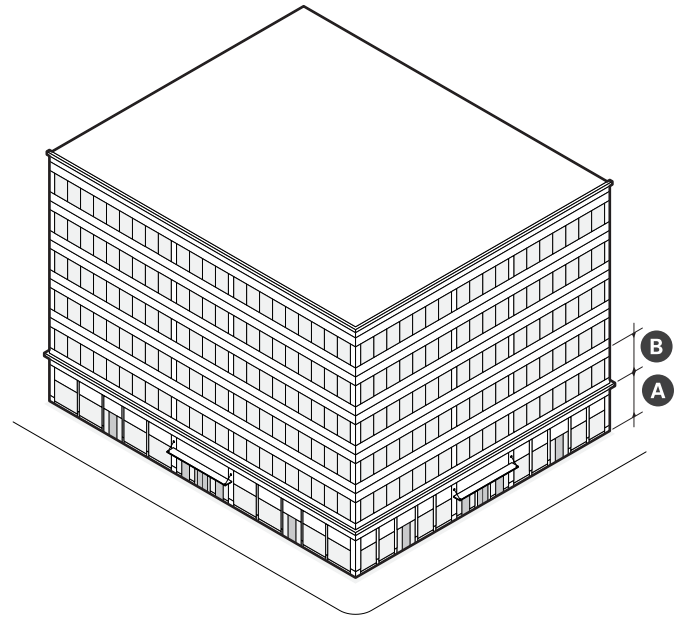

Main Massing	
A BUILDING WIDTH (max)	200 ft
FACADE Build Out (min)	–
Primary Front	80%
Secondary Front	65%
B FLOOR PLATE (max)	30,000 sf
C GROUND STORY Height	14 ft
D UPPER STORY Height	10 ft
E Number of Stories (min/max)	3 6
F UPPER STORY STEP-BACK (min)	–
Primary/Secondary Front	10 ft
Side/Rear ABUTTING NR	30 ft
G BUILDING Height, Feet (max)	85 ft
Roof Type	Flat

Facade Composition	
A GROUND STORY FENESTRATION (min)	70%
B UPPER STORY FENESTRATION (min/max)	20% 70%
BLANK WALL (max)	20 ft

Use & Occupancy	
GROUND STORY Entrance Spacing (max)	30 ft
Commercial Space Depth (min)	30 ft

4. MID-RISE DISTRICTS

Mid-Rise 6 (MR6)

4.4.9. Commercial Building (continued)

- e. DEVELOPMENT Benefits
 - i. DEVELOPMENT is subject to the provisions of Article 12: DEVELOPMENT Benefits of this Ordinance. Where the provisions of this section conflict with those of Article 12, the provisions of Article 12 apply.
 - ii. DEVELOPMENT of a general building must provide linkage payments as specified on Table 4.4.9.

Table 4.4.9 Linkage

Commercial GROSS FLOOR AREA	Affordable Housing Linkage	Employment Linkage
30,000 sf or less	None	None
Over 30,000 sf	\$10/sf	\$2.46/sf

4.4.10 Lab Building

A large FLOOR PLATE, multi-STORY PRINCIPAL BUILDING TYPE purpose built for occupation by laboratory and research & DEVELOPMENT PRINCIPAL USES. Floor space is typically custom designed as complex, technically sophisticated, and mechanically intensive wet or dry labs or vivariums for animal research.

The following images are examples of the lab BUILDING TYPE and are intended only for illustrative purposes.



4. MID-RISE DISTRICTS

Mid-Rise 6 (MR6)

4.4.10 Lab Building (continued)

a. LOT Standards

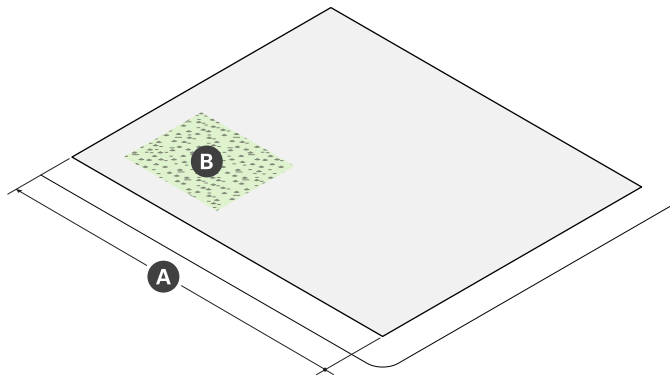

Lot Dimensions	
A LOT WIDTH (min)	30 ft

Lot Development	
LOT Coverage (max)	100%
GREEN SCORE	--
Minimum	0.20
Ideal	0.25
B OPEN SPACE (min)	15%

b. BUILDING Placement

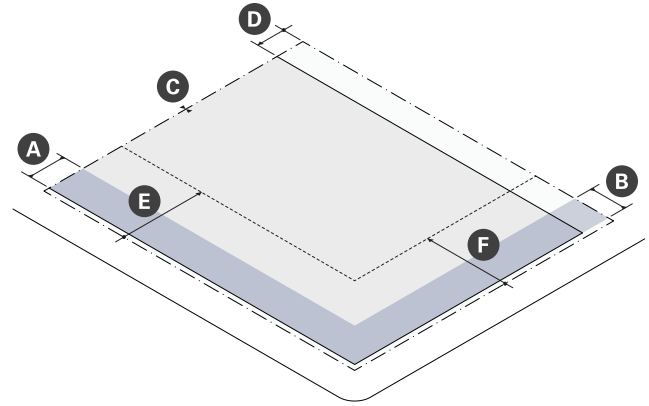

Building Setbacks		
A Primary Front SETBACK (min/max)	2 ft	15 ft
B Secondary Front SETBACK (min/max)	2 ft	15 ft
C Side SETBACK (min)	0 ft	
Side SETBACK ABUTTING NR or LHD (min)	5 ft	
D Rear SETBACK (min)	10 ft	
Rear SETBACK ABUTTING NR or LHD (min)	15 ft	

Parking Setbacks	
E Primary Front SETBACK (min)	30 ft
F Secondary Front SETBACK (min)	30 ft

4.4.10 Lab Building (continued)

c. Massing & Height

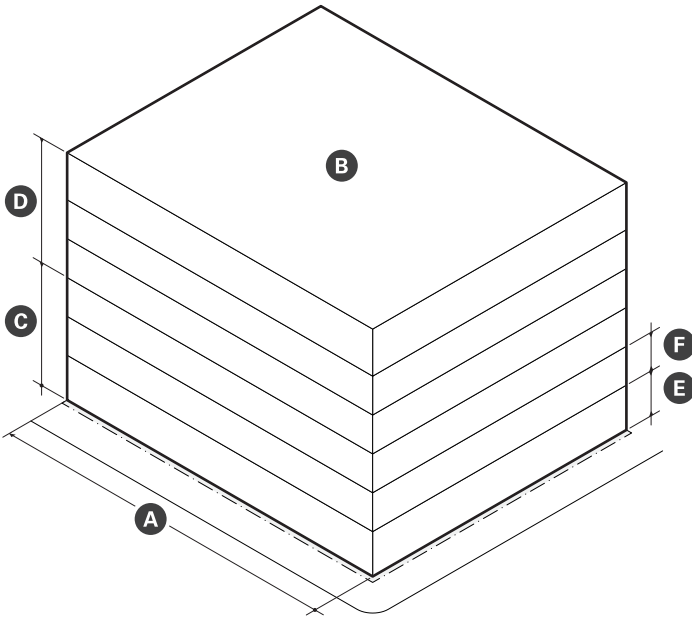

d. Uses & Features

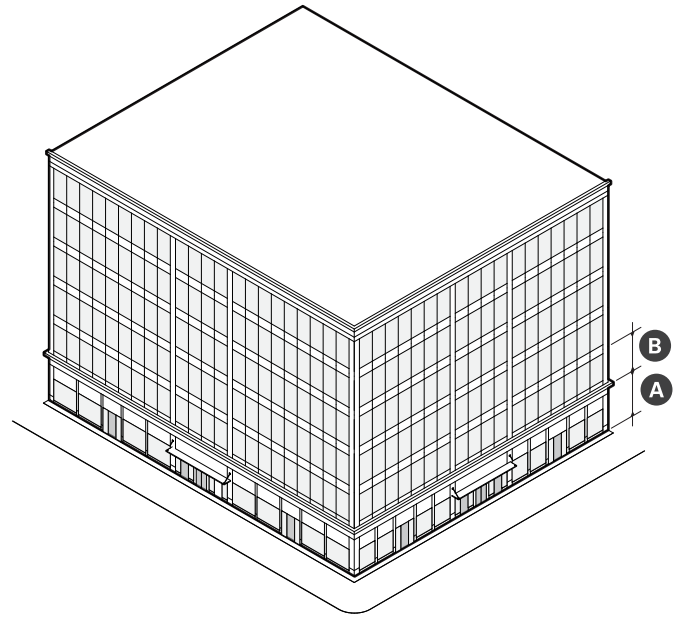

Main Massing	
A Width (max)	200 ft
FACADE Build Out	
Primary Front (min)	80%
Secondary Front (min)	65%
B FLOOR PLATE	30,000 sf
C GROUND STORY Height	14 ft
D UPPER STORY Height	10 ft
E Number of Stories (min)	3 6
F UPPER STORY STEP-BACK (min)	
Primary/Secondary Front	10 ft
Side/Rear ABUTTING NR	30 ft
G BUILDING Height, Feet (max)	95 ft
Roof Type	Flat

Facade Composition	
A GROUND STORY FENESTRATION (min)	70%
B UPPER STORY FENESTRATION (min/max)	20% 70%
BLANK WALL (max)	20 ft

Use & Occupancy	
Entrance Spacing (max)	30 ft
Commercial Space Depth (min)	30 ft

4. MID-RISE DISTRICTS

Mid-Rise 6 (MR6)

4.4.10 Lab Building (continued)

- e. DEVELOPMENT Benefits
 - i. DEVELOPMENT is subject to the provisions of Article 12: DEVELOPMENT Benefits of this Ordinance. Where the provisions of this section conflict with those of Article 12, the provisions of Article 12 apply.
 - ii. DEVELOPMENT of a general building must provide linkage payments as specified on Table 4.4.10.

Table 4.4.10 Linkage

Commercial GROSS FLOOR AREA	Affordable Housing Linkage	Employment Linkage
30,000 sf or less	None	None
Over 30,000 sf	\$10/sf	\$2.46/sf

11. Building Components

- a. BUILDING COMPONENTS are ACCESSORY elements attached to the MAIN MASSING of a PRINCIPAL BUILDING.
- b. BUILDING COMPONENTS are permitted by Site Plan Approval as specified on Table 4.4.11.
 - i. At least one (1) storefront is required for each GROUND STORY commercial space.
- c. BUILDING COMPONENTS not identified on Table 4.4.11 are prohibited.
- d. Unless otherwise specified, BUILDING COMPONENTS may attach to other BUILDING COMPONENTS to create assemblies of components.

Table 4.4.11 Building Components

	Apartment BUILDING	General BUILDING	Commercial BUILDING	Lab BUILDING
Awning	N	P	P	P
Entry Canopy	P	P	P	P
Lobby Entrance	P	P	P	P
Storefront	N	P	P	P
Stoop	P	N	N	N
Bay Window	P	P	P	P
Balcony	P	P	N	N
Arcade	N	N	N	N

P - Permitted N - Not Permitted

4. MID-RISE DISTRICTS

Mid-Rise 6 (MR6)

e. Awning

- i. An awning is a wall mounted frame covered with fabric or other material that provides shade and weather protection over a storefront or BUILDING entrance.

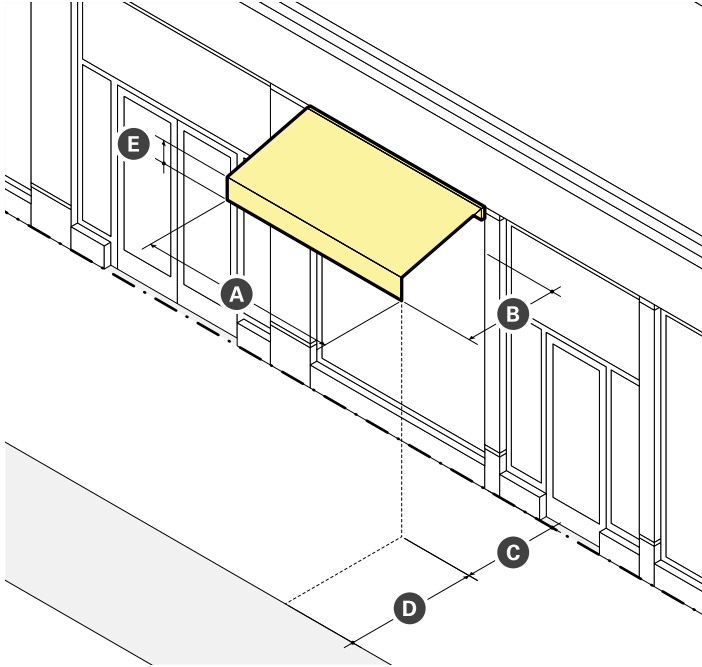

Dimensions	
A Width (min)	See ii. Standards
B Projection (min)	3 ft
C CLEARANCE (min)	8 ft
Front SETBACK ENCROACHMENT (max)	100%
D SETBACK from Curb (min)	2 ft
E Valance Height (max)	12 in

- ii. Standards
 - a). Awnings must be securely attached to and supported by the BUILDING and must fit the windows or doors the awning is attached to.
 - b). An awning must be made of durable, weather-resistant material that is water repellent.
 - c). Internally illuminated or back-lit awnings are prohibited.
 - d). An awning that projects over the sidewalk of a public THOROUGHFARE requires compliance with all City Ordinances.

f. Entry Canopy

- i. An entry canopy is a wall-mounted STRUCTURE that provides shade and weather protection over a storefront or BUILDING entrance.

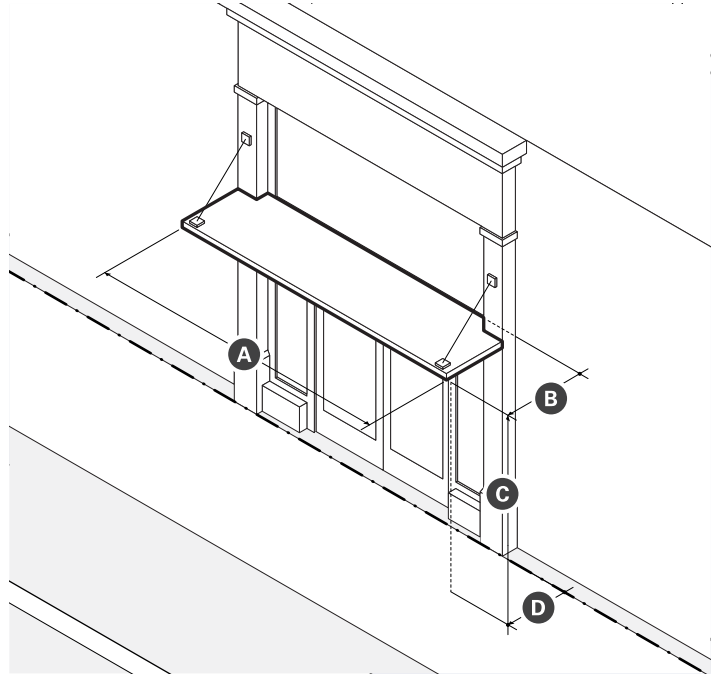

Dimensions	
A Width (min)	See ii. Standards
B Projection (min)	3 ft
C CLEARANCE (min)	8 ft
D Front SETBACK ENCROACHMENT (max)	100%
SETBACK from Curb (min)	2 ft

- ii. Standards
 - a). Entry canopies must be visually supported by brackets, cables, or rods.
 - b). The width of an entry canopy must be equal to or greater than the width of the doorway surround or exterior casing it is mounted over.

g. Lobby Entrance

- i. A lobby entrance is a non-load bearing assembly of entry doors and windows providing ACCESS and light to the lobby of a BUILDING.

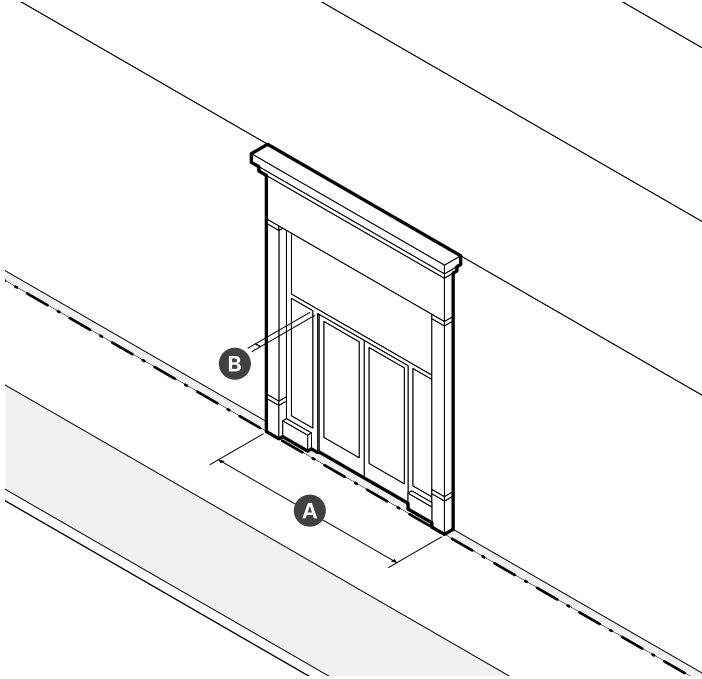

Dimensions		
A Width (min/max)	15 ft	30 ft
B Height (min)	80% of GROUND STORY Height	
Recessed Entrance Width (max)	15 ft	
Recessed Entrance Depth (max)	5 ft	

- ii. Standards
 - a). When a lobby entrance is set back from the FRONT LOT LINE, the FRONTAGE AREA must be paved.

h. Storefront

- i. A storefront is a non-load bearing assembly of commercial entry doors and windows providing ACCESS and light to a commercial space and a place to display goods, services, and SIGNS.

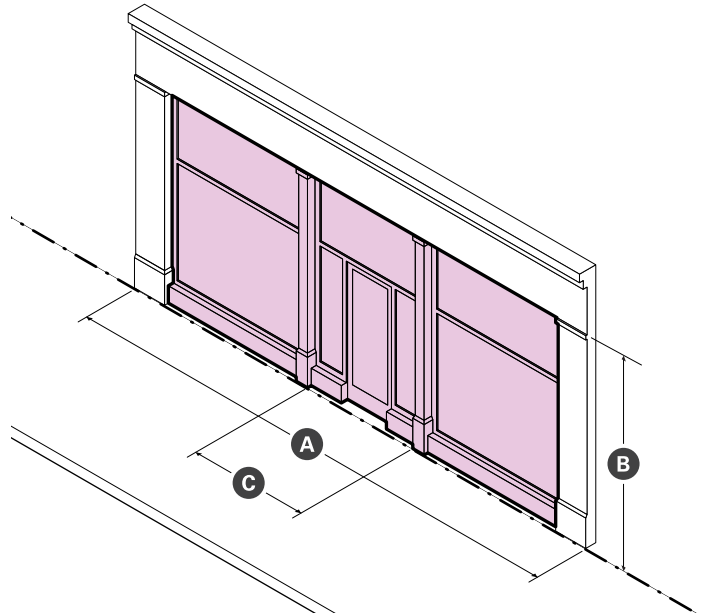

Dimensions		
A Width (min/max)	15 ft	30 ft
B Height (min)	80% of GROUND STORY Height	
Display Window Height (min)	8 ft	
Recessed Entrance Width (max)	15 ft	
Recessed Entrance Depth (max)	5 ft	

- ii. Standards
 - a). An unobstructed view of the interior space or a lighted and maintained merchandise display(s) must be provided for a depth of at least four (4) feet behind storefront display windows.
 - b). When storefronts are set back from the FRONT LOT LINE, the FRONTAGE AREA must be paved.
 - c). When present, awnings and canopies must be mounted between columns, PILASTERS, OR PIERS; above doorways and display windows; and below the SIGN BAND.
 - d). Exterior security grilles, gates, and roll-down security doors and windows are prohibited.

4. MID-RISE DISTRICTS

Mid-Rise 6 (MR6)

i. Stoop

- i. A stoop is a set of stairs with a landing leading to the entrance of a BUILDING.

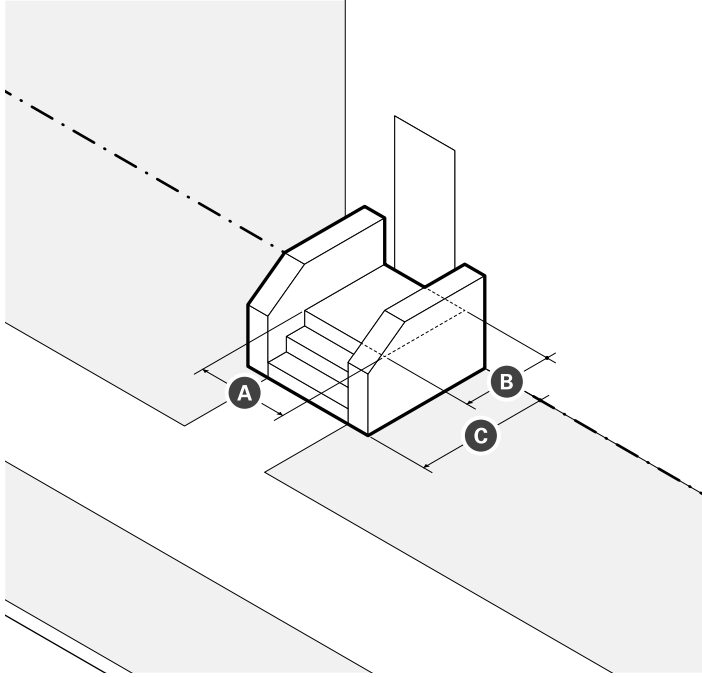

Dimensions	
A Landing Width (min)	4 ft
B Landing Depth (min)	4 ft
C Front SETBACK ENCROACHMENT (max)	100%

- ii. Standards
 - a). Paving, excluding driveways, must match the ABUTTING sidewalk unless paved with pervious, porous, or permeable materials.
 - b). Stairs may be recessed into the BUILDING FACADE when the BUILDING is set back four (4) feet or less.
 - c). Stairs are not permitted to ENCROACH onto any ABUTTING sidewalk.
 - d). Stairs may be built perpendicular or parallel to the BUILDING FACADE, but must lead directly to ground level or an ABUTTING sidewalk.

j. Bay Window

- i. A bay window is an assembly of windows projecting from a building to provide additional HABITABLE space, increased light, multi-directional views, and ARTICULATION to an exterior wall.

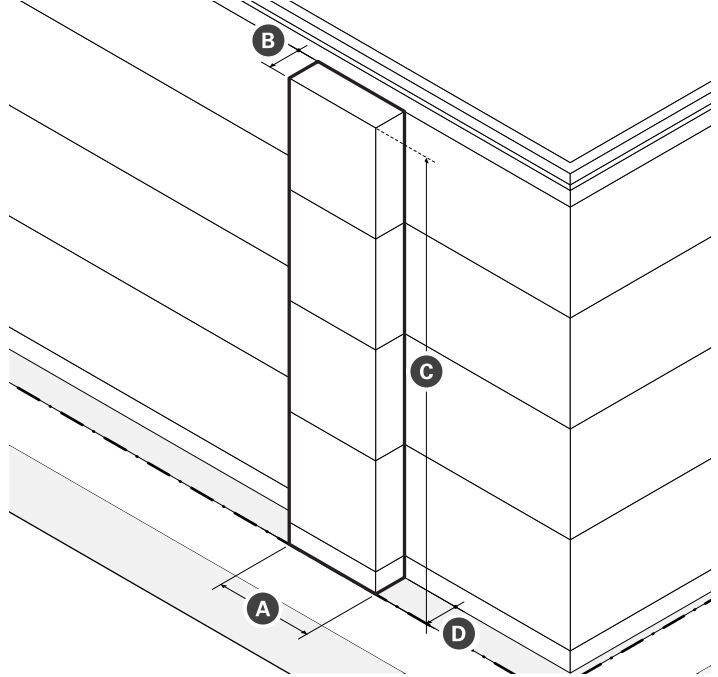

Dimensions	
A Width (max)	16 ft
B Projection (max)	3 ft
C Height (max)	Height of BUILDING in Stories
D Front SETBACK ENCROACHMENT (max)	3 ft
FENESTRATION (min)	60%

- ii. Standards
 - a). Bay windows, including box and bow windows, must include at least three (3) windows.
 - b). The cumulative width of multiple bays may equal up to fifty percent (50%) of the width of the exterior wall from which the bays project.
 - c). Bays projecting over the sidewalk of a public THOROUGHFARE must have at least two (2) stories of CLEARANCE and be compliant with all City Ordinances.

k. Balcony

- i. A balcony is a platform with a railing that provides outdoor AMENITY SPACE.

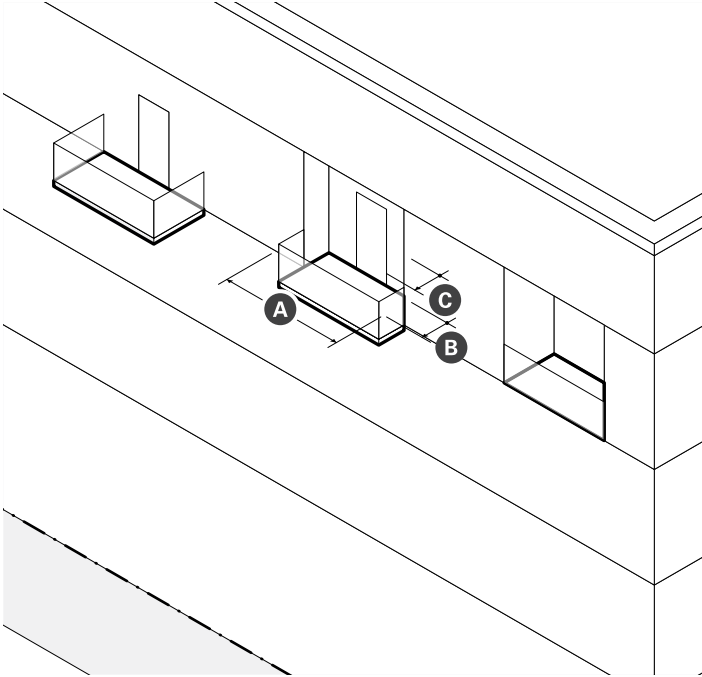

Dimensions	
A Width (min)	5 ft
B Depth (max)	5 ft
D Area (min)	50 ft
CLEARANCE (min)	10 ft
Permitted Front SETBACK ENCROACHMENT (max)	6 ft

- ii. Standards
 - a). Balconies may be recessed, projecting, a combination of the two, or terraced as part of the roof of a portico, porch, or bay.
 - b). A balcony that projects over the sidewalk of a public THOROUGHFARE requires compliance with all City Ordinances.
 - c). The guard rail of any balcony oriented toward a FRONT LOT LINE must permit visual supervision of the PUBLIC REALM through the posts and rails.
 - d). The guard rail of any balcony oriented toward a side OF REAR LOT LINE ABUTTING the NR district must include sight-obscuring visual screening so that it is at least fifty percent (50%) opaque.

l. Arcade

- i. An arcade is a pedestrian walkway covered by the upper floors of a BUILDING. The GROUND STORY FACADE is SETBACK and upper floors are supported by a colonnade or supports.

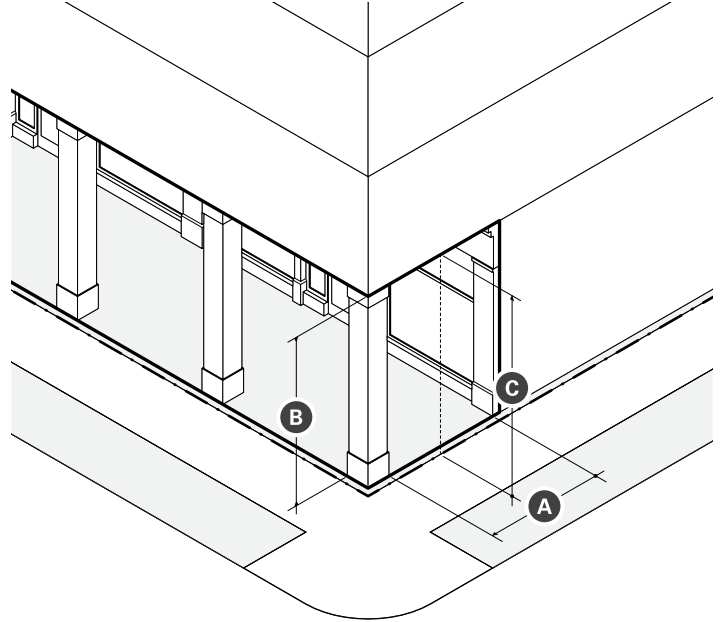

Dimensions		
A Depth (min/max)	10 ft	15 ft
B Height (max)	1 STORY	
C CLEARANCE (min/max)	14 ft	24 ft

- ii. Standards
 - a). Arcades must extend the entire width of a BUILDING and must have a consistent depth.
 - b). Support columns or PIERS may be spaced no farther apart than they are tall.
 - c). Arcades are considered part of the BUILDING for the purpose of measuring FACADE build out.
 - d). Arcades may be combined only with storefront and lobby entrance frontages.
 - e). The finished ceiling of an arcade interior may be arched or flat, but must have a greater CLEARANCE than the openings between columns OR PIERS.

4. MID-RISE DISTRICTS

Mid-Rise 6 (MR6)

12. Facade Design

- a. FACADES must provide solid material framing each storefront and lobby entrance as follows:
 - i. PILASTERS or columns supporting a horizontal lintel and CORNICE;
 - ii. a spandrel positioned between PILASTERS or columns that extend from upper stories of the building to the ground; or
 - iii. flat wall above and to either side of a void or punched opening.
- b. Storefronts and lobby entrances must be set within the resulting frame provided for each by the FACADE.
- c. Materials framing each storefront or lobby entrance may be integrated into the design of the FACADE or customized for individual storefronts and lobby entrances.
- d. Mechanical louvers necessary for venting purposes are not permitted in the required frame, but may be incorporated into any storefront or lobby entrance system.
- e. FACADES must differentiate the GROUND STORY of the building from the upper stories through horizontal ARTICULATION, a change in material, or a change in window size or pattern to create a distinct base to the building FACADE. The entire height of the GROUND STORY must be included in the FACADE base.
- f. Buildings of five (5) or more stories should include, at least, the entire height of the first two (2) stories in the required base. The design of the base may not shift up or down across the width of the FACADE.

- g. For buildings with more than one FACADE, the design of the base must align horizontally at the corner.
- h. FACADES must provide surface relief from the average plane of the FACADE by at least four (4) inches, through the USE of architectural elements such as bay windows, columns, CORNER BOARDS, CORNICES, door and window surrounds, moldings, PIERS, PILASTERS, recessed storefronts or lobby entrances, seat walls, sills, wall thickness, and recessed or projecting windows.
- i. The FACADE of any building greater than one hundred (100) feet in width must be designed as two (2) or more separate and distinct facades of differing architectural design so that the building appears to be multiple buildings. The facade designs must include a change in CORNICE, roof eave, or parapet design from one another.

13. Architectural Design Guidelines

- a. FACADES should be visually divided into a series of ARCHITECTURAL BAYS that are derived, in general, from the building's structural bay spacing.
- b. PIERS, PILASTERS, or other features defining each ARCHITECTURAL BAY should either extend all the way to the ground or terminate at any horizontal ARTICULATION defining the base of the building.
- c. ARCHITECTURAL BAYS should align, in general, with individual or groups of storefronts and lobby entrances.
- d. PIERS, PILASTERS, or other features defining each ARCHITECTURAL BAY should always project forward and be uninterrupted by any horizontal articulation, excluding

Figure 4.4.12 (a) Storefront & Lobby Entrance Framing

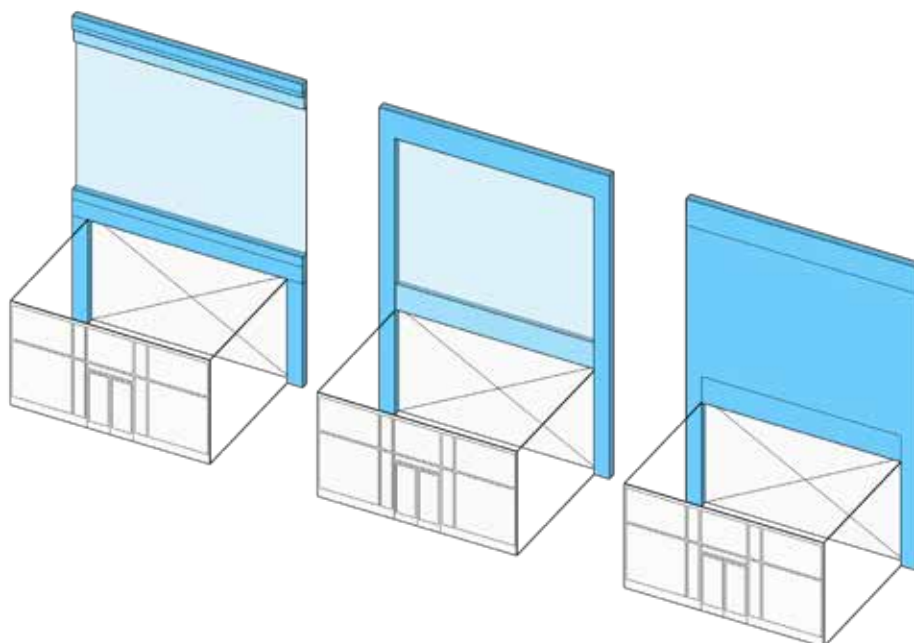

any horizontal ARTICULATION USED to differentiate the base of the building.

- e. The FACADE of buildings with five (5) or more stories should be visually divided into, at least, a horizontal tripartite division (a base, middle, and top). The horizontal divisions may not shift up or down across the width of the FACADE.
- f. Vents, exhausts, and other utility features on building FACADES should be architecturally integrated into the design of the building and should be located to minimize adverse effects on pedestrian comfort along sidewalks and within OPEN SPACES.
- g. Buildings at TERMINATED VISTAS should be ARTICULATED with design features that function as focal points.
- h. FENESTRATION glazing should be inset from the plane of exterior wall surfaces.
- i. RIBBON WINDOWS should be avoided.
- j. Monotonous and repetitive storefront or lobby systems, awnings, canopies, SIGN types, colors, or designs should be avoided.
- k. Storefronts and lobby entrances should include awnings or canopies to provide weather protection for pedestrians and reduce glare for storefront display areas. Awnings should be open-ended and operable.
- l. Lobby entrances for UPPER STORY USES should be optimally located, well defined, clearly visible, and separate from the entrance for other GROUND STORY USES.
- m. Lobbies should be limited in both width and total area to preserve floor space and frontage for other GROUND STORY USES. Buildings should USE any combination of FACADE ARTICULATION, a double-height ceiling, a distinctive doorway, a change in wall material, a change in paving material within the FRONTAGE AREA, or some other architectural element(s) to make lobbies visual and materially distinctive.
- n. The selection of materials, FENESTRATION, and ornamentation should result in a consistent and harmonious composition that appears as a unified whole rather than a collection of unrelated parts, no matter the style.
- o. The type and color of materials should be kept to a minimum, preferably three (3) or fewer.
- p. Two (2) or more wall materials should be combined only one above the other, except for bay windows.
- q. Wall materials appearing heavier in weight should be used below wall materials appearing lighter in weight (wood and metal above brick, and all three above stone)
- r. Horizontal or vertical board siding or shingles, regardless of material, should be avoided.
- s. Architectural details and finish materials for the base of a building should be constructed of architectural concrete or pre-cast cementitious panels, natural or cast stone, heavy gauge metal panels, glazed or unglazed architectural terracotta, or brick.
- t. Exterior Insulation and Finish Systems (EIFS) should be avoided.

Figure 4.4.12 (b) Appearance of Two Buildings



4. MID-RISE DISTRICTS

Mid-Rise 6 (MR6)

14. Use Provisions

- a. General
 - i. The USE of real property is subject to the provisions of Article 9: USE Provisions of this Ordinance. Where the provisions of this section conflict with those of Article 9, the provisions of Article 9 apply.
 - ii. USE categories are permitted as specified on Table 4.1.14. USE categories not identified on Table 4.1.14 are prohibited.
 - iii. All USES must comply with any USE-specific standards applicable for each USE in §9.2 USE Definitions & Limitations.
 - iv. USES permitted by Special Permit require additional DEVELOPMENT review in accordance with §15.2.1 Special Permits.
- b. USE Limitations
 - i. The USE of any GROUND STORY commercial space fronting a PEDESTRIAN STREET, excluding lobbies for UPPER STORY USES, is limited to the following PRINCIPAL USE categories:
 - a). Arts & Creative Enterprise
 - b). Food & Beverage Service
 - c). Retail Sales
 - d). Civic & Institutional
- c. Required USES
 - i. A minimum of five percent (5%) of the gross leasable commercial floor space in any BUILDING must be provided as LEASABLE FLOOR AREA for USES from the Arts & Creative Enterprise USE category.
- d. Increases in Density
 - i. Existing STRUCTURES may not be altered to conflict with number of DWELLING UNITS permitted for each BUILDING TYPE.

Table 4.4.14 Permitted Uses

Use Category Specific Use	MR6
Arts & Creative Enterprise	
Artisinal Production	P
Arts Exhibition	P
Arts Sales & Services	P
Co-Working	P
Design Services	P
Shared Workspaces & Arts Education	P
Cannabis Establishment	
Cannabis Cultivation	P
Cannabis Retail Sales	SP
Cannabis Research & Development	P
Cannabis Testing Laboratory	P
Civic & Institutional	
Community Center	P
Hospital	SP
Library	P
Minor Utility Facility	SP
Museum	P
Private Non-Profit Club or Lodge	SP
Public Service	P
Religious & Educational Uses Protected by M.G.L. 40A. Sec. 3	P

P - Permitted SP - Special Permit Required N - Not Permitted

Table 4.4.14 Permitted Uses (continued)

Use Category Specific Use	MR6
Commercial Services	
Animal Services (as noted below)	--
Commercial Kennel	SP
Pet Grooming	P
Pet Daycare & Training	SP
Veterinarian	SP
Assembly or Entertainment	SP
Banking & Financial Services (except as noted below)	P
Personal Credit	SP
Broadcast and/or Recording Studio	P
Building & Home Repair Services	SP
Business Support Services	P
Caterer/Wholesale Food Production	SP
Day Care Service (as noted below)	--
Adult Day Care Center	P
Child Day Care Center	P
Educational Services	P
Maintenance & Repair of Consumer Goods	P
Personal Services (except as noted below)	P
Body-Art Services	SP
Fitness Services	P
Funeral Services	SP
Health Care Services	SP
Formula Personal Services	SP
Recreation Services	SP
Vehicle Parking (as noted below)	--
Bike Share Parking	P
Car Share Parking (3 or fewer spaces)	P
Car Share Parking (4 or more spaces)	P
Commercial Parking	P
Food and Beverage Service	
Bar/Restaurant/Tavern	P
Bakery/Café/Coffee Shop	P
Formula Food & Beverage Service	SP

P - Permitted SP - Special Permit Required N - Not Permitted

Table 4.4.14 Permitted Uses (continued)

Use Category Specific Use	MR6
Lodging	
Bed & Breakfast	SP
Hotel or Hostel	SP
Office	
General Office	P
Research and Development and/or Laboratory	P
Residential	
Household Living	SP
Group Living (except as follows)	SP
Community or Group Residence	P
Dormitory, Fraternity or Sorority	SP
Homeless Shelter	SP
Nursing Home/Assisted Living Facility	SP
Rooming House	SP
Retail Sales	
Building/Home Supplies & Equipment	SP
Consumer Goods (except as follows)	P
Alcohol Sales	SP
Firearms Sales	N
Pet Store	SP
Formula Retail	SP
Fresh Food Market or Grocery Store	P
Farm/Vendor Market	P
Urban Agriculture	
Farming (as noted below)	--
Commercial Farming	P
Community Farming	P
Community Gardening	P

P - Permitted SP - Special Permit Required N - Not Permitted

4. MID-RISE DISTRICTS

Mid-Rise 6 (MR6)

Table 4.4.14 Permitted Uses (continued)

Use Category Specific Use	MR6
Accessory Uses	
Home Occupations (as noted below)	--
Home Office	P
Urban Agriculture (as noted below)	--
Apiculture	P
Aviculture	P
Commercial Farming	P
Residential Gardening	P

P - Permitted SP - Special Permit Required N - Not Permitted

15. Development Standards

- a. General
 - i. DEVELOPMENT is subject to the provisions of Article 10: DEVELOPMENT STANDARDS of this Ordinance. Where the provisions of this section conflict with those of Article 10, the provisions of Article 10 apply.
- b. SIGNS
 - i. A SIGN, individual numerals or letters, or a nonelectrical nameplate identifying the property address is required for all real property as follows:
 - a). Each GROUND STORY non-residential USE must identify the STREET address either on the PRINCIPAL ENTRANCE door or above or beside the PRINCIPAL ENTRANCE of the USE.
 - b). All residential BUILDING TYPES must identify the STREET address either on the PRINCIPAL ENTRANCE door, above or beside the PRINCIPAL ENTRANCE, or on a mailbox.
 - ii. Address SIGNS must be made easily visible through the USE of colors or materials that contrast with the background material they are attached to and must be conspicuously located to provide visibility from the THOROUGHFARE that the BUILDING faces.
 - iii. Address SIGNS must be twelve (12) inches in height or less and may include the name of the occupant.

16. Parking & Mobility

- a. General
 - i. DEVELOPMENT is subject to the provisions of Article 11: Parking & Mobility of this Ordinance. Where the provisions of this section conflict with those of Article 11, the provisions of Article 11 apply.
 - ii. Vehicular parking must be provided as specified on Table 4.1 (d), except as follows:
 - a). Non-residential USES with five thousand (5,000) square feet or less of GROSS LEASABLE FLOOR AREA are exempt from any minimum requirements of Table 4.1. (d).
 - b). Any CHANGE IN USE within a non-residential STRUCTURE constructed before the effective date of this Ordinance, provided that the change is to a permitted USE, is exempt from any minimum requirements of Table 4.1 (d).
 - iii. There are no parking requirements for ACCESSORY USES.
 - iv. MOTOR VEHICLE PARKING spaces may be shared between USES on the same LOT and buildings on the same BLOCK in accordance with §11.3 SHARED PARKING.
- b. Type
 - i. MOTOR VEHICLE PARKING may be provided as above ground STRUCTURED PARKING or underground STRUCTURED PARKING. SURFACE PARKING is prohibited.
- c. Driveways
 - i. New driveways require a permit from the City Engineer.
 - ii. Driveways must be compliant with all City Ordinances and constructed in accordance with all standards established by relevant City Departments.
 - iii. Driveways are not permitted in the FRONTAGE AREA between a BUILDING and the FRONT LOT LINE.
 - iv. Driveways may be no wider than twenty four (24) feet in the FRONTAGE AREA of a LOT.
 - v. Driveways may provide ACCESS in whole or in part on or across an ABUTTING LOT(s), provided that an ACCESS EASEMENT exists between all PROPERTY OWNERS.
- d. Parking Design
 - i. The design of all parking is subject to §11.1 Bicycle Parking and §11.2 MOTOR VEHICLE PARKING of this Ordinance.
- e. Parking Location
 - i. Required vehicular parking, excluding any required handicapped parking, may be provided on a contiguous LOT under the same ownership as the LOT that the parking will serve as follows:
 - a). Pedestrian ACCESS to off-SITE vehicular parking must be via a paved sidewalk or walkway.
 - b). A lease, recorded covenant, or other comparable legal instrument guaranteeing long

- term USE of the SITE must be provided to the review board or BUILDING OFFICIAL and executed and filed with the Registry of Deeds.
 - ii. For real property located in more than one municipality, MOTOR VEHICLE PARKING need not be located within the City of Somerville.
- f. Unbundled Parking
 - i. MOTOR VEHICLE PARKING spaces must be rented or leased as an option rather than a requirement of the rental, lease, or purchase of a DWELLING UNIT or non-residential floor space.
 - ii. Bicycle parking must be provided at no cost or fee to customers, visitors, employees, tenants, and residents.
- g. Parking Relief
 - i. Relief from the parking standards of Table 4.4 (d) requires a Special Permit.
 - a). In addition to the review criteria for all Special Permits specified in §15.2.1.e. Review Criteria, the review board shall make findings considering the following in its discretion to approve or deny a special permit authorizing relief from the parking standards of Table 4.4 (d):
 - i). The supply and demand of on-STREET parking in the neighborhood, as determined through a parking study.
 - ii). MOBILITY MANAGEMENT programs and services provided by the APPLICANT to reduce the demand for parking.
 - iii). That parking provided in excess of any maximum permitted does not result in the increase in impervious LOT AREA.

17. Public Realm

- a. Sidewalks
 - i. When DEVELOPMENT OCCURS on any LOT ABUTTING a sidewalk that is less than twelve (12) feet in total width, the BUILDING must be set-back an additional distance to accommodate expansion of the ABUTTING sidewalk to a width of at least twelve (12) feet. The minimum and maximum front SETBACKS for each BUILDING TYPE are increased accordingly.
- b. Sidewalk CURB CUTS
 - i. A CURB CUT requires a permit from the City Engineer and must be compliant with all City Ordinances.
 - ii. Unless otherwise specified, the City Engineer may not permit more than one (1) CURB CUT per FRONT LOT LINE of a LOT.
 - iii. CURB CUTS are prohibited along all THOROUGHFARES designated as a PEDESTRIAN STREET.
 - iv. CURB CUTS must be located to minimize conflicts with pedestrians and bicyclists and must have a clear distance from fire hydrants, STREET TREES, utility

4. MID-RISE DISTRICTS

Mid-Rise 6 (MR6)

Table 4.4.16 Vehicular Parking

Use Category Specific Use	BICYCLE		MOTOR VEHICLE	
	Short-Term (min)	Long-Term (min)	Within a TRANSIT AREA ¹ (max)	Outside of a TRANSIT AREA ¹ (min)
Arts & Creative Enterprise				
All Permitted Uses	1 / 10,000 sf	1 / 3,000 sf	1 / 800 sf	1 / 1,000 sf
Cannabis Establishment				
Cannabis Retail Sales	1 / 2,500 sf	1 / 10,000 sf	1 / 1,500 sf	1 / 750 sf
Cannabis Research & Development	1 / 20,000 sf	1 / 5,000 sf	1 / 1,000 sf	1 / 1,000 sf
Cannabis Testing Laboratory	1 / 20,000 sf	1 / 5,000 sf	1 / 1,000 sf	1 / 1,000 sf
Civic & Institutional				
Community Center	1 / 10,000 sf	4 / 10,000 sf	1 / 1,800 sf	1 / 600 sf
Educational Facility	1.0 / classroom	4.0 / classroom	1.5 / classroom	3.0 / classroom
Hospital	10 per entrance	1 / 5,000 sf	1 / 200 sf	1 / 1,000 sf
Library	1 / 3,000 sf	1 / 5,000 sf	1 / 800 sf	1 / 500 sf
Minor Utility Facility	n/a	n/a	n/a	n/a
Museum	1 / 2,000 sf	1 / 10,000 sf	1 / 800 sf	1 / 500 sf
Private Non-Profit Club or Lodge	1 / 2,000 sf	1 / 10,000 sf	1 / 200 sf	1 / 1,000 sf
Commercial Services				
Animal Services (as noted below)	–	–	–	–
Commercial Kennel	1 / 2,500 sf	1 / 10,000 sf	1 / 500 sf	1 / 500 sf
Pet Grooming	1 / 2,500 sf	none	1 / 500 sf	1 / 500 sf
Pet Day Care or Training	1 / 2,500 sf	none	1 / 500 sf	1 / 500 sf
Veterinarian	1 / 2,500 sf	1 / 5,000 sf	1 / 500 sf	1 / 500 sf
Assembly or Entertainment	1 / 40 seats	1 / 10,000 sf	1 / 6 seats	1 / 6 seats
Banking & Financial Services (except as noted below)	1 / 2,000 sf	1 / 10,000 sf	1 / 450 sf	1 / 400 sf
Broadcast and/or Recording Studio	1 / 2,500 sf	1 / 10,000 sf	1 / 800 sf	1 / 600 sf
Building & Home Repair Services	1 / 2,500 sf	1 / 10,000 sf	1 / 1,000 sf	1 / 2,000 sf
Business Support Services	1 / 2,500 sf	1 / 10,000 sf	1 / 900 sf	1 / 600 sf
Caterer/Wholesale Food Production	1 / 2,500 sf	1 / 10,000 sf	1 / 800 sf	1 / 1,000 sf
Day Care Service	2	1 / 10,000 sf	1 / 900 sf	1 / 600 sf
Maintenance & Repair of Consumer Goods	1 / 2,500 sf	1 / 10,000 sf	1 / 750 sf	1 / 1,000 sf
Personal Services (except as noted below)	1 / 2,500 sf	1 / 10,000 sf	1 / 750 sf	1 / 1,000 sf
Health Care Services	1 / 2,000 sf	1 / 10,000 sf	1 / 500 sf	1 / 300 sf
Recreation Services	1 / 2,500 sf	1 / 10,000 sf	–	–

sf - Gross Leasable Square Footage DU - Dwelling Unit RU - Rooming Unit

¹ See the Transit Area Map

Table 4.4.16 Vehicular Parking (continued)

Use Category Specific Use	BICYCLE		MOTOR VEHICLE	
	Short-Term (min)	Long-Term (min)	Within a TRANSIT AREA ¹ (max)	Outside of a TRANSIT AREA ¹ (min)
Food and Beverage Service				
All Permitted Uses	1 / 1,000 sf	1 / 5,000 sf	1 / 300 sf	1 / 500 sf
Lodging				
Bed & Breakfast	none	2 / 10 rooms	1 / 4 rooms	1 / 4 rooms
Hotel or Hostel	1 / 20 rooms	1 / 10 rooms	1 / 2 rooms	1 / 2 rooms
Office				
Co-Working	1 / 20,000 sf	1 / 3,000 sf	1 / 1,200 sf	1 / 800 sf
General Office	1 / 20,000 sf	1 / 3,000 sf	1 / 900 sf	1 / 650 sf
Research and Development and/or Laboratory	1 / 20,000 sf	1 / 5,000 sf	1 / 1,000 sf	1 / 1,000 sf
Residential				
Household Living	0.1 / DU	1.0 / DU	1.0 / DU	1.0 / DU
Group Living (except as follows)	0.05 / room	0.5 / room	–	–
Community or Group Residence	–	–	–	–
Dormitory, Fraternity or Sorority	0.1 / room	0.5 / room	.05 / bed	1.0 / 4 beds
Homeless Shelter	–	–	4.0	4.0
Nursing Home/Assisted Living Facility	–	–	1 / 6 beds	1 / 6 beds
Single Room Occupancy Housing	–	–	1 / 6 beds	1 / 4 beds
Retail Sales				
Building/Home Supplies & Equipment	1 / 2,500 sf	1 / 10,000 sf	1 / 1,000 sf	1 / 1,000 sf
Consumer Goods (except as follows)	1 / 2,500 sf	1 / 10,000 sf	1 / 1,500 sf	1 / 750 sf
Formula Retail	1 / 2,500 sf	1 / 10,000 sf	1 / 1,500 sf	1 / 750 sf
Fresh Food Market or Grocery Store	1 / 1,000 sf	1 / 10,000 sf	1 / 500 sf	1 / 1,500 sf
Farm/Vendor Market	n/a	n/a	n/a	1 / 1,500 sf

sf - Gross Leasable Square Footage DU - Dwelling Unit RU - Rooming Unit

¹ See the Transit Area Map

4. MID-RISE DISTRICTS

Mid-Rise 6 (MR6)

poles, and other furnishings as deemed necessary by the City Engineer.

- a). CURB CUTS for commercial or high-volume driveways should be at least one-hundred (100) feet from an UNSIGNALIZED or SIGNALIZED intersection.
- b). CURB CUTS for residential driveways should be at least twenty (20) feet from an UNSIGNALIZED intersection and at least forty (40) feet from a SIGNALIZED intersection.
- v. The interior width of a CURB CUT (between curb stones) may be no wider than the driveway, vehicular entrance, or loading facility it serves.
- vi. A DRIVEWAY APRON may be installed only within the furnishing zone of a sidewalk and must be constructed in accordance with all standards established by relevant City Departments.
- vii. The grade, cross slope, and clear width of the walkway of a sidewalk must be maintained between the DRIVEWAY APRON and the ABUTTING driveway. The appearance of the walkway (ie. scoring pattern or paving material) must indicate that, although a vehicle may cross, the area traversed by a vehicle remains part of the sidewalk.

Figure 4.4.17 Sidewalk Curb Cuts

