

# 5 HIGH-RISE DISTRICTS

- 5.1 HIGH-RISE (HR) .....235**
  - Character Description 235
  - Intent 236
  - Purpose 236
  - Applicability 236
  - Development Review 236
  - Building Types 236
  - Building Components 257
  - Private Frontages 260
  - Building Design Standards 265
  - Architectural Design Guidelines 265
  - Use Provisions 268
  - Vehicular Parking 272
  - Site Development 275



## 5.1 HIGH-RISE (HR)

### 1. Character Description

The High-Rise district is characterized by a variety of moderate to large floor plate high-rise buildings. Buildings are set close to the sidewalk and have an upper stories stepped back to define a mid-rise street wall that supports pedestrian activity and a sense of place. The district is primarily commercial, with a variety of employment opportunities. Ground floor uses typically address the needs of residents and employees from the immediate neighborhood, but can also provide goods and services to the larger Somerville community and visitors from the broader Boston metropolitan area.



# 5. HIGH-RISE DISTRICTS

High-Rise (HR)

## 2. Intent

- a. To implement the Urban Mixed Use context from the Future Land Context Map of SomerVision.
- b. To accommodate the development of areas appropriate for an intense mix of multi-story multi-unit, mixed-use, and commercial buildings; neighborhood-, community-, and region-serving uses; and a wide variety of employment opportunities.

## 3. Purpose

- a. To permit the development of multi-unit, mixed-use, and commercial high-rise buildings.
- b. To provide quality commercial spaces and permit small and medium-scale, neighborhood-, community-, and region-serving commercial uses.
- c. To provide upper story residential unit types, sizes, bedroom counts, and affordability for smaller households.

## 4. Applicability

- a. The section is applicable to all real property within the High-Rise district as shown on the maps of the Official Zoning Atlas of the City of Somerville.

## 5. Development Review

- a. Development on any lot requires the submittal of a development review application to the Building Official.
- b. Proposed development may or may not necessitate the need for Site Plan Approval, a Special Permit, or a

Variance based on the nature of the proposal. In such cases, additional development review is required in accordance with Article 15: Administration.

- i. The Planning Board is the decision making authority for all development that requires Site Plan Approval or a Special Permit.
- ii. The Zoning Board of Appeals is the Review Board for all Variances.
- c. Upon verification that no additional development review is necessary or completion of the required development review, a Zoning Compliance Certificate shall be issued by the Building Official to certify compliance with the provisions and procedures of this Ordinance.

## 6. Building Types

- a. One (1) principal building type may be built on each lot.
- b. The following building types are permitted by Site Plan Approval in the High-Rise district:
  - i. General Building
  - ii. Commercial Building
  - iii. Lab Building
  - iv. Mid-Rise Podium Tower
  - v. Block Building
- c. Apartment Buildings are prohibited on any lot fronting a pedestrian street.
- d. Accessory structures are regulated according to Article 10.0 Development Standards of this Ordinance.

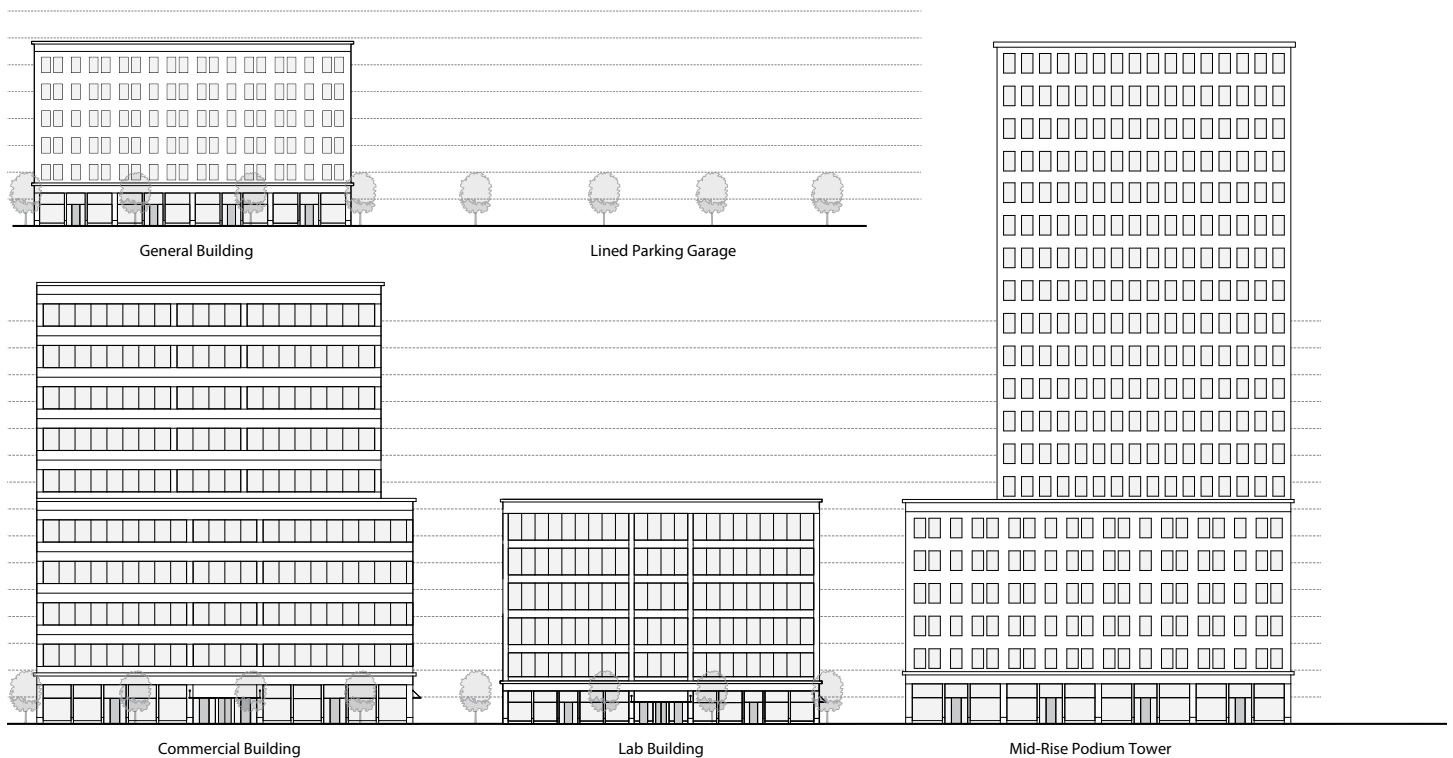

7. General Building

A multi-story principal building type with ground floor commercial uses and no limitations or restrictions on the use of upper stories. The upper stories of a general building are typically residential, but a large variety exists. As the number of stories increases, it becomes more likely for the upper stories of a general building to host commercial uses as well as residential.

The following images are examples of the general building type and are intended only for illustrative purposes.



# 5. HIGH-RISE DISTRICTS

High-Rise (HR)

## 7. General Building (continued)

a. Lot Standards

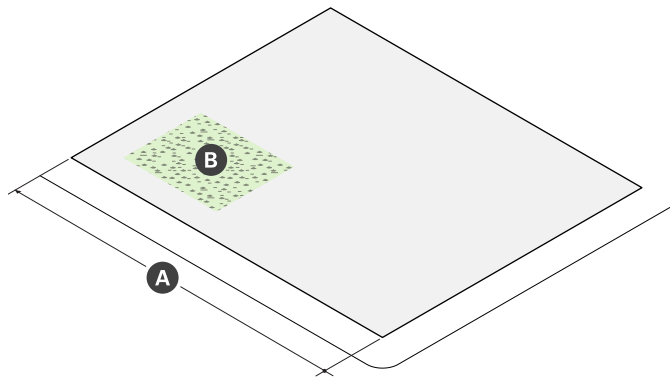

Lot Dimensions	
<b>A</b> Width (min)	30 ft

Lot Development	
<b>B</b> Lot Coverage (max)	100%
<b>C</b> Green Factor (min)	0.20

b. Building Placement

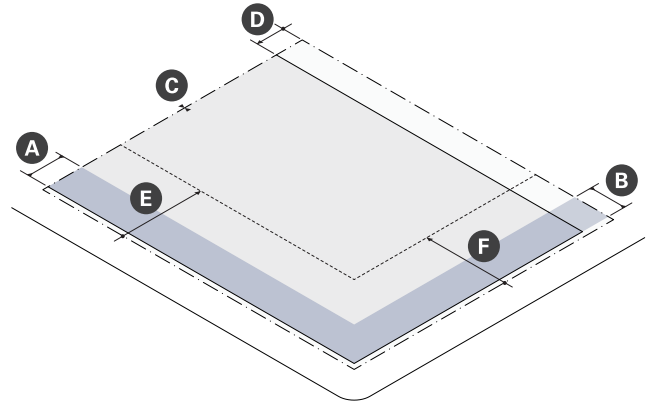

Building Setbacks		
<b>A</b> Primary Front Setback (min/max)	2 ft	15 ft
<b>B</b> Secondary Front Setback (min/max)	2 ft	15 ft
<b>C</b> Side Setback (min)	0 ft	
Side Setback Abutting NR or LHD (min)	5 ft	
<b>D</b> Rear Setback (min)	10 ft	
Rear Setback Abutting NR or LHD (min)	15 ft	

Parking Setbacks	
<b>E</b> Primary Front Setback (min)	30 ft
<b>F</b> Secondary Front Setback (min)	30 ft

## 7. General Building (continued)

### c. Massing & Height

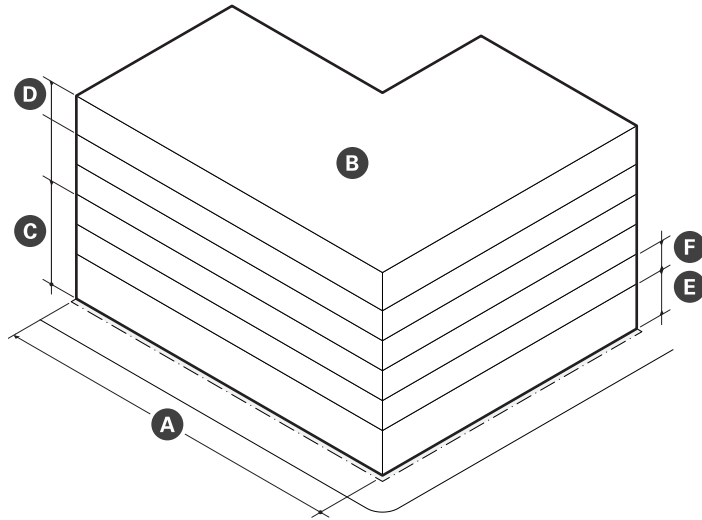

Main Body	
<b>A</b> Building Width (max)	200 ft
Facade Build Out (min)	--
Front Street	80%
Side Street	65%
<b>B</b> Floor Plate (max)	30,000 sf
<b>C</b> Building Height, Stories (min)	3 stories
<b>D</b> Building Height, Stories (max)	6 stories
<b>E</b> Ground Story Height (min)	14 ft
<b>F</b> Upper Story Height (min)	10 ft
Building Height, Feet (max)	80 ft
Roof Type	Flat

### d. Uses & Features

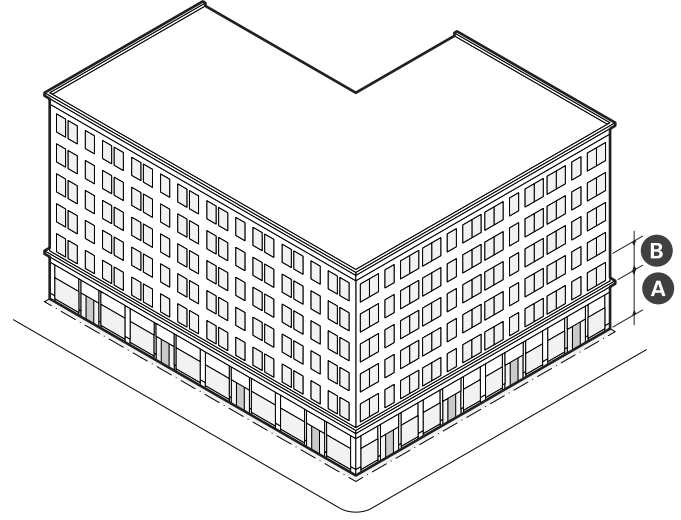

Facade Composition	
<b>A</b> Ground Story Fenestration (min)	70%
<b>B</b> Upper Story Fenestration (min/max)	20% 50%
Blank Wall (max)	20 ft

Use & Occupancy	
Ground Story Entrance Spacing (max)	30 ft
Commercial Space Depth (min)	30 ft
Density Factor	--
Base	875
100% Affordable	625
Outdoor Amenity Space (min)	1/DU

## 5. HIGH-RISE DISTRICTS

### High-Rise (HR)

- e. Housing
  - i. A general building with six (6) or more dwelling units, whether established through new construction or the conversion of any other existing building type, must provide affordable housing in accordance with Article 12: Development Benefits.
- f. Design Guidelines
  - i. Fenestration patterns and window configurations should break the direct line of sight between neighboring properties to every extent practicable. Translucent glass on the bottom half of windows or strategically placed landscape elements should be utilized if it is not practical to off-set windows in ways that minimize privacy impacts.
  - ii. Outdoor amenity spaces that are elevated such as roof decks, fully projecting balconies, and upper story rear porches should provide sight obscuring visual screening at the sides to increase privacy, security, and limit views of abutting properties from elevated vantage points.



8. Commercial Building

A multi-story principal building type limited to commercial uses on all floors. Ground floor space is primarily occupied by retail or eating & drinking establishment uses with narrow lobby entrances for upper floor uses. Floor space on upper floors is sometimes occupied by retail uses that do not rely on the visibility of storefronts at sidewalk level.

The following images are examples of the commercial building type and are intended only for illustrative purposes.



# 5. HIGH-RISE DISTRICTS

High-Rise (HR)

## 8. Commercial Building (continued)

a. Lot Standards

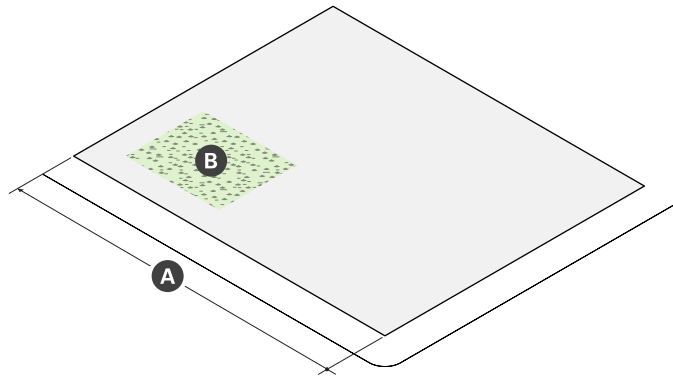

Lot Dimensions	
<b>A</b> Width (min)	30 ft

Lot Development	
<b>B</b> Lot Coverage (max)	100%
<b>C</b> Green Factor (min)	0.20

b. Building Placement

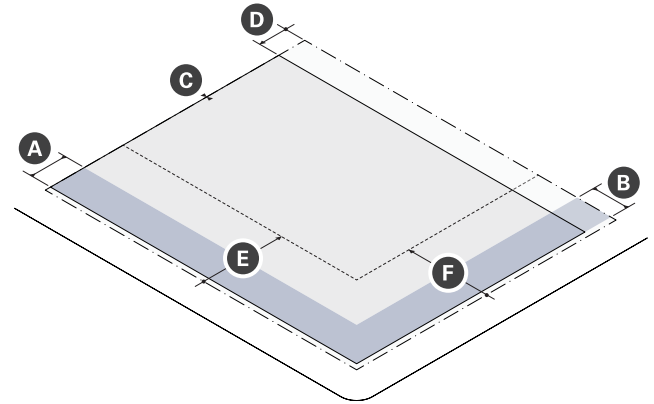

Building Setbacks		
<b>A</b> Primary Front Setback (min/max)	2 ft	15 ft
<b>B</b> Secondary Front Setback (min/max)	2 ft	15 ft
<b>C</b> Side Setback (min)	0 ft	
Side Setback Abutting NR or LHD (min)	5 ft	
<b>D</b> Rear Setback (min)	10 ft	
Rear Setback Abutting NR or LHD (min)	15 ft	

Parking Setbacks	
<b>E</b> Primary Front Setback (min)	30 ft
<b>F</b> Secondary Front Setback (min)	30 ft

## 8. Commercial Building (continued)

### c. Massing & Height

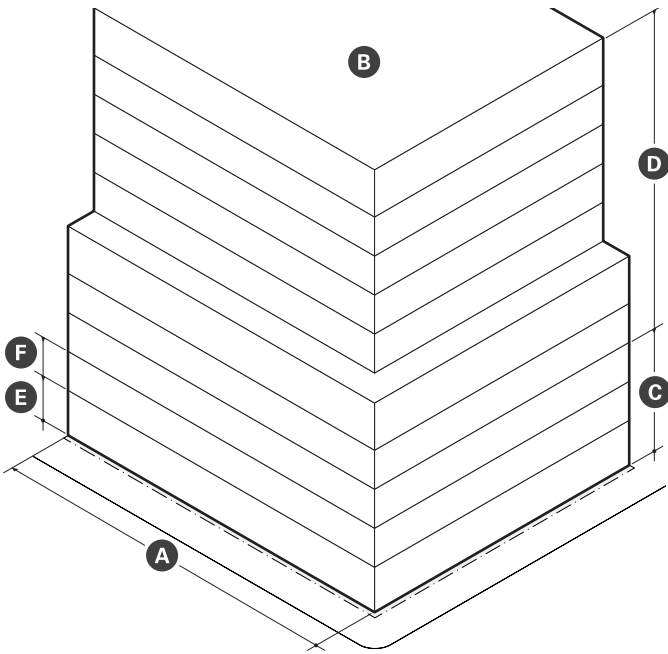

### d. Uses & Features

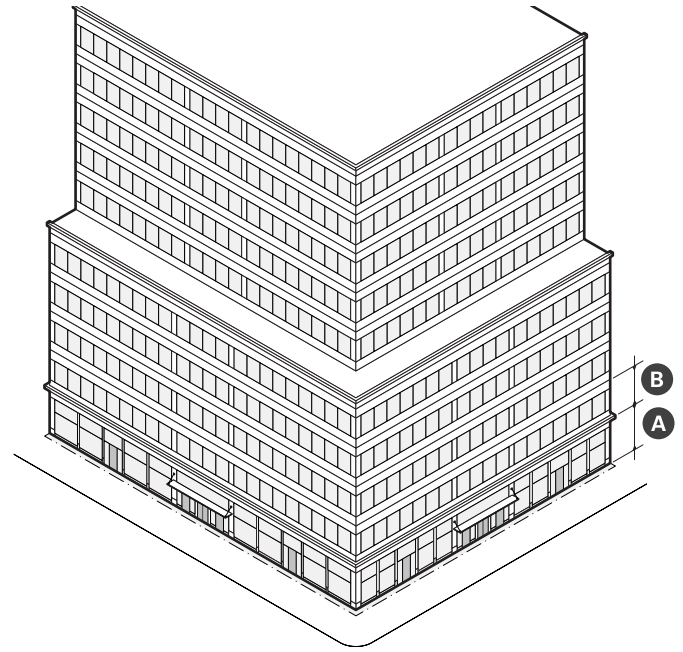

#### Main Body

<b>A</b> Building Width (max)	200 ft
Facade Build Out (min)	--
Front Street	80%
Side Street	65%
<b>B</b> Floor Plate (max)	30,000 sf
<b>C</b> Building Height, Stories (min)	3 stories
<b>D</b> Building Height, Stories (max)	10 stories
<b>E</b> Ground Story Height (min)	14 ft
<b>F</b> Upper Story Height (min)	10 ft
Building Height, Feet (max)	145 ft
Roof Type	Flat

#### Facade Composition

<b>A</b> Ground Story Fenestration (min)	70%
<b>B</b> Upper Story Fenestration (min/max)	20% 70%
Blank Wall (max)	20 ft

#### Use & Occupancy

Entrance Spacing (max)	30 ft
Commercial Space Depth (min)	30 ft

## 5. HIGH-RISE DISTRICTS

High-Rise (HR)

e. Reserved

## 9. Lab Building

A multi-story building type purpose built for laboratory and research & development uses. Floor space is typically custom designed as vivariums for animal research or complex, technically sophisticated, and mechanically intensive wet or dry labs.

The following images are examples of the lab building type and are intended only for illustrative purposes.



# 5. HIGH-RISE DISTRICTS

High-Rise (HR)

## 9. Lab Building (continued)

a. Lot Standards

b. Building Placement

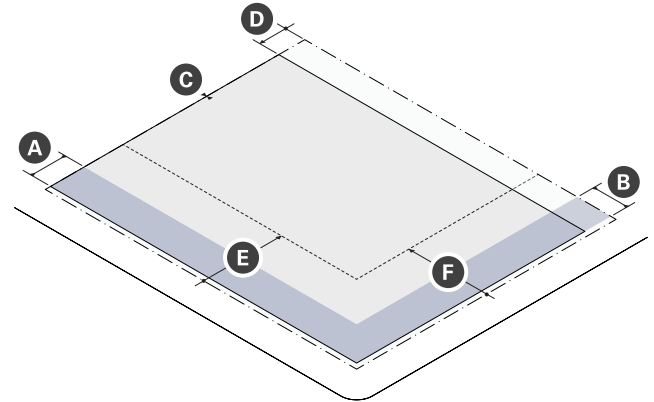
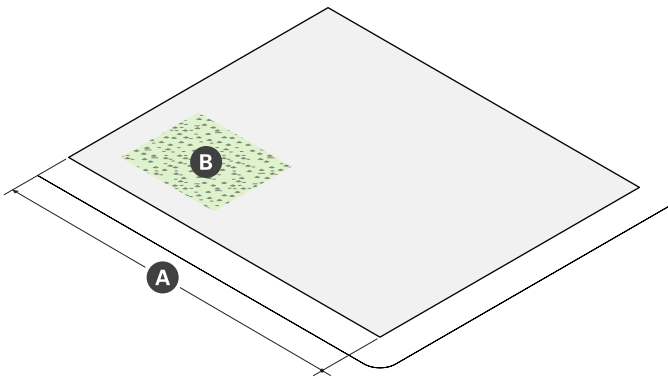

Lot Dimensions	
<b>A</b> Width (min)	30 ft

Lot Coverage	
<b>B</b> Lot Coverage (max)	100%
<b>C</b> Green Factor (min)	0.20

Building Setbacks		
<b>A</b> Primary Front Setback (min/max)	2 ft	15 ft
<b>B</b> Secondary Front Setback (min/max)	2 ft	15 ft
<b>C</b> Side Setback (min)	0 ft	
Side Setback Abutting NR or LHD (min)	5 ft	
<b>D</b> Rear Setback (min)	10 ft	
Rear Setback Abutting NR or LHD (min)	15 ft	

Parking Setbacks	
<b>E</b> Primary Front Setback (min)	30 ft
<b>F</b> Secondary Front Setback (min)	30 ft

## 9. Lab Building (continued)

### c. Massing & Height

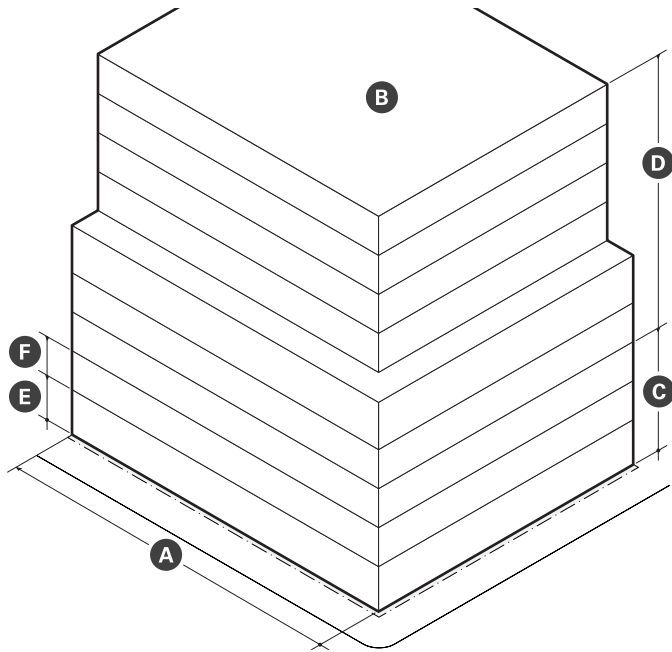

### d. Uses & Features

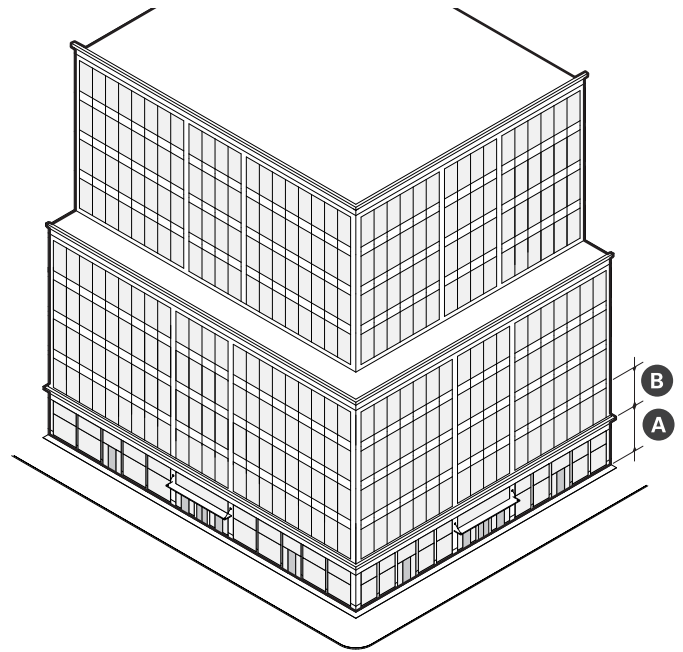

#### Main Body

<b>A</b> Width (max)	240 ft
Facade Build Out (min)	--
Front Street	80%
Side Street	65%
<b>B</b> Floor Plate	35,000 sf
<b>C</b> Building Height, Stories (min)	4 stories
<b>D</b> Building Height, Stories (max)	9 stories
<b>E</b> Ground Story Height	14 ft
<b>F</b> Upper Story Height	10 ft
Building Height, Feet (max)	145 ft
Roof Type	Flat

#### Facade Composition

<b>A</b> Ground Story Fenestration (min)	70%
<b>B</b> Upper Story Fenestration (min/max)	20% 70%
Blank Wall (max)	20 ft

#### Use & Occupancy

Entrance Spacing (max)	30 ft
Commercial Space Depth (min)	30 ft

## 5. HIGH-RISE DISTRICTS

High-Rise (HR)

e. Reserved



**10. Mid-Rise Podium Tower**

A large floor plate, multi story building type composed of a residential point tower above a mid-rise general building serving as a podium. The podium defines the public realm, provides ground story commercial space, and typically incorporates structured parking. The slender point tower provides density, access to natural light, and views of the sky while also limiting excessive shadows and reduced wind impacts at ground level.

The following images are examples of the mid-rise podium tower building type and are intended only for illustrative purposes.



# 5. HIGH-RISE DISTRICTS

High-Rise (HR)

## 10. Mid-Rise Podium Tower (continued)

a. Lot Standards

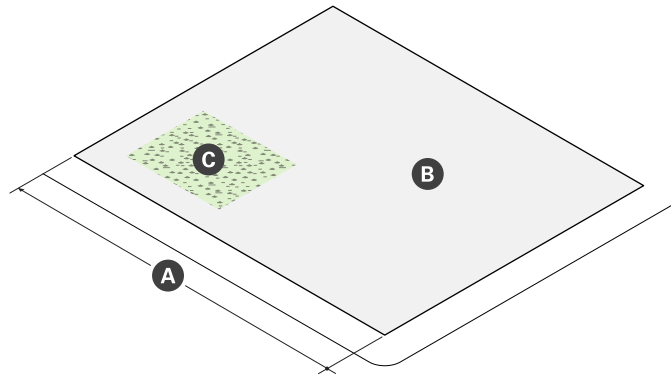

Lot Dimensions	
<b>A</b> Width (min)	150 ft

Lot Development	
<b>B</b> Lot Coverage (max)	100%
<b>C</b> Green Factor (min)	0.20

b. Building Placement

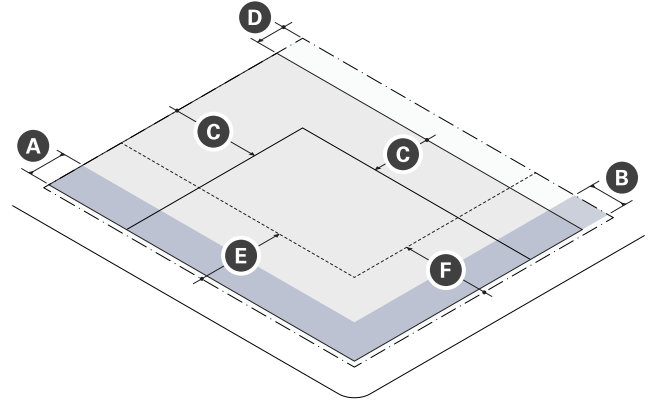

Building Setbacks		
<b>A</b> Primary Front Setback (min/max)	2 ft	15 ft
<b>B</b> Secondary Front Setback	2 ft	15 ft
<b>C</b> Side Setback (min)	--	
Podium	0 ft	
Podium Abutting NR or LHD	5 ft	
Point Tower	30 ft	
Point Tower Abutting NR or LHD	60 ft	
<b>D</b> Rear Setback (min)	--	
Podium	10 ft	
Podium Abutting NR or LHD	15 ft	
Point Tower	30 ft	
Point Tower Abutting NR or LHD	60 ft	

Parking Setbacks	
<b>E</b> Primary Front Setback (min)	30 ft
<b>F</b> Secondary Front Setback (min)	30 ft

## 10. Mid-Rise Podium Tower (continued)

c. Massing & Height

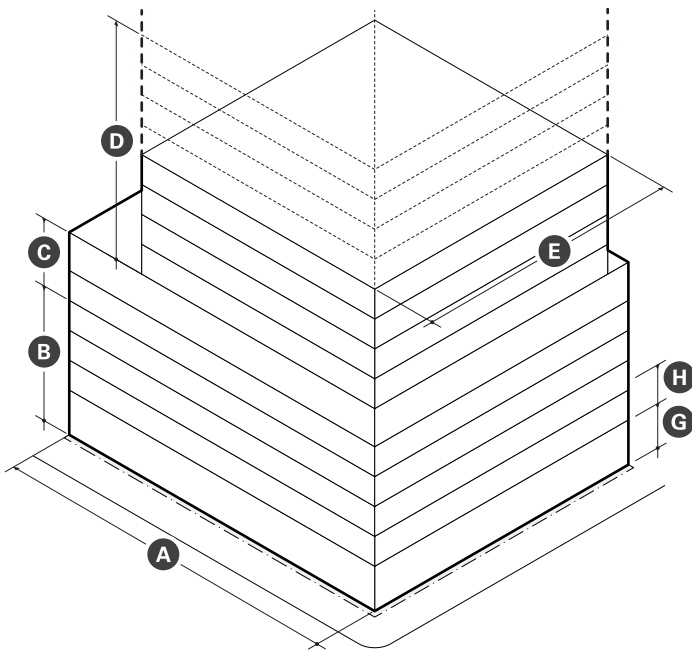

d. Uses & Features

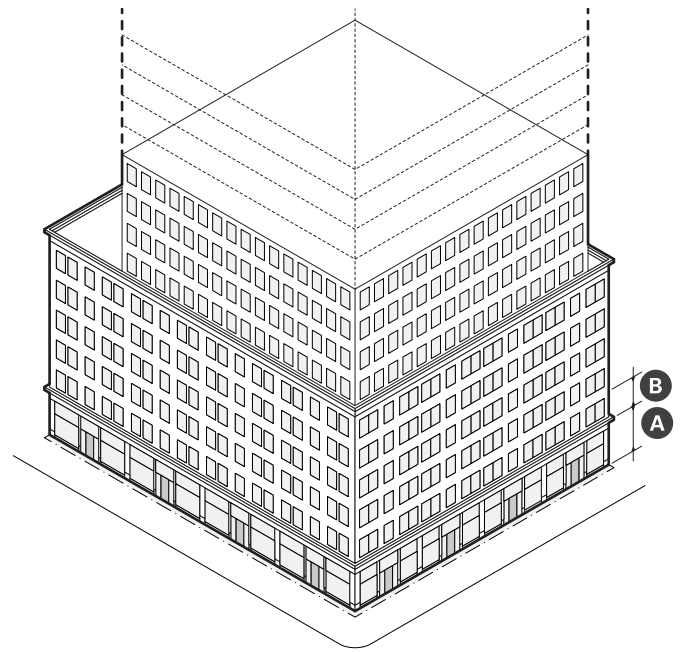

Main Body	
<b>A</b> Width (max)	250 ft
Facade Build Out (min)	80%
Floor Plate (max)	--
Podium	35,000 sf
Point Tower	10,000 sf
<b>B</b> Building Height, Stories (min)	4 stories
Building Height, Stories (max)	--
<b>C</b> Podium	6 stories
<b>D</b> Point Tower	24 stories
Point Tower Dimensions (max)	--
<b>E</b> Width/Depth	100 ft
<b>F</b> Diagonal	145 ft
<b>G</b> Ground Story Height (min)	14 ft
<b>H</b> Upper Story Height (min)	10 ft
Building Height, Feet (max)	--
Podium	80 ft
Point Tower	275 ft
Roof Type	Flat

Facade Composition	
<b>A</b> Ground Story Fenestration (min)	70%
<b>B</b> Upper Story Fenestration (min/max)	20% 50%
Blank Wall (max)	20 ft

Use & Occupancy	
Entrance Spacing (max)	30 ft
Commercial Space Depth (min)	30 ft
Density Factor	--
Base	875
100% Affordable	625
Outdoor Amenity Space (min)	1/DU

## 5. HIGH-RISE DISTRICTS

### High-Rise (HR)

- e. Housing
  - i. A mid-rise podium tower with six (6) or more dwelling units, whether established through new construction or the conversion of any other existing building type, must provide mandatory affordable housing in accordance with Article 12: Development Benefits.
- f. Design Guidelines
  - i. Fenestration patterns and window configurations should break the direct line of sight between neighboring properties to every extent practicable. Translucent glass on the bottom half of windows or strategically placed landscape elements should be utilized if it is not practical to off-set windows in ways that minimize privacy impacts.
  - ii. Outdoor amenity spaces that are elevated such as roof decks, fully projecting balconies, and upper story rear porches should provide sight obscuring visual screening at the sides to increase privacy, security, and limit views of abutting properties from elevated vantage points.

### 11. Block Building

A very large floor plate, multi-story building type composed of one or more towers above a mid-rise general building serving as a podium. The podium has frontage on three (3) or more thoroughfares or civic spaces and defines the public realm, provides ground story commercial space, and typically incorporates structured parking. The upper stories of a block building can host commercial uses as well as residential.

The following images are examples of the block building type and are intended only for illustrative purposes.



# 5. HIGH-RISE DISTRICTS

High-Rise (HR)

## 11. Block Building (continued)

a. Lot Standards

b. Building Placement

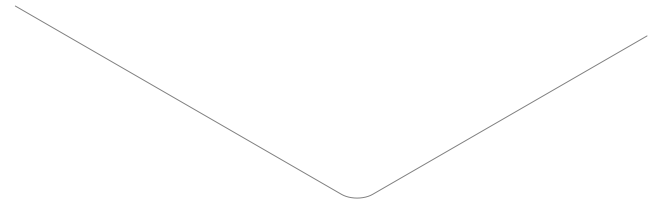
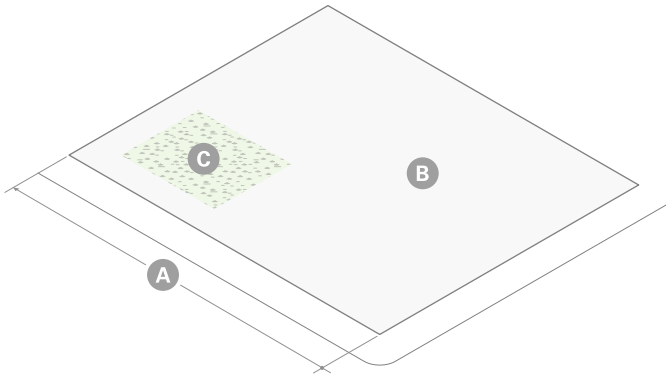

Lot Dimensions	
<b>A</b> Width (min)	200 ft

Lot Development	
<b>B</b> Lot Coverage (max)	100%
<b>C</b> Green Factor (min)	0.20

Building Setbacks		
<b>A</b> Primary Front Setback (min/max)	2 ft	15 ft
<b>B</b> Secondary Front Setback (min/max)	2 ft	15 ft
<b>C</b> Side Setback (min)	0 ft	
Side Setback Abutting NR or LHD (min)	5 ft	
<b>E</b> Rear Setback (min)	10 ft	
Rear Setback Abutting NR or LHD (min)	15 ft	

Parking Setbacks	
Primary Front Setback (min)	30 ft
Secondary Front Setback (min)	30 ft

## 11. Block Building (continued)

### c. Massing & Height

### d. Uses & Features

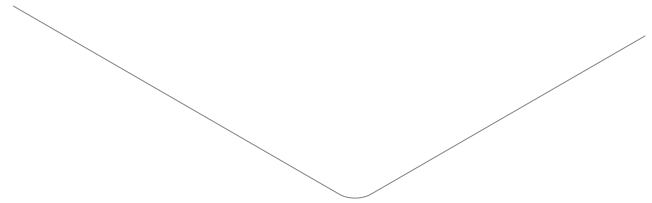
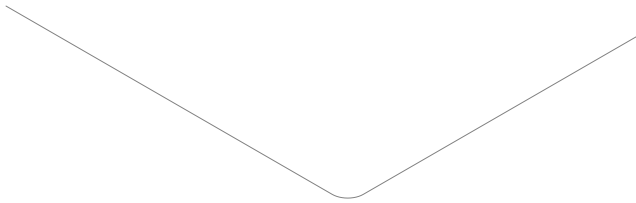

Main Body	
<b>A</b> Building Width (max)	500 ft
Facade Build Out (min)	--
Front Street	100%
Side Street	100%
Floor Plate (max)	--
Podium	n/a
Tower(s)	30,000 sf
<b>B</b> Building Height, Stories (min)	3 stories
Building Height, Stories (max)	--
<b>C</b> Podium	6 stories
<b>D</b> Tower(s)	10 stories
<b>D</b> Ground Story Height (min)	14 ft
<b>E</b> Upper Story Height (min)	10 ft
Podium	80 ft
Point Tower	145 ft
Roof Type	Flat

Facade Composition	
<b>A</b> Ground Story Fenestration (min)	70%
<b>B</b> Upper Story Fenestration (min/max)	20% 50%
Blank Wall (max)	20 ft

Use & Occupancy	
Ground Story Entrance Spacing (max)	30 ft
Commercial Space Depth (min)	30 ft
Density Factor	--
Base	875
100% Affordable	625
Outdoor Amenity Space (min)	1/DU

# 5. HIGH-RISE DISTRICTS

High-Rise (HR)

e. Reserved



**12. Building Components**

- a. Building components are accessory features that increase the habitable square footage or enhance the usefulness of a building.
- b. Building components are permitted as specified on Table 5.1 (a).
- c. Building components not expressly authorized are prohibited.

**TABLE 5.1 (a) HR Building Components**

	Awning	Entry Canopy	Bay	Balcony	Specific Standards
General Building	P	P	P	P	§5.1.7
Commercial Building	P	P	P	P	§5.1.8
Lab Building	P	P	P	N	§5.1.9
Mid-Rise Podium Tower	P	P	P	P	§5.1.10
Block Building	P	P	P	P	§5.1.11

P - Permitted      SP - Special Permit Required      N - Not Permitted

# 5. HIGH-RISE DISTRICTS

High-Rise (HR)

## D. Awning

- i. A wall mounted, pitched covering extending from a building to provide shade and weather protection for pedestrians.

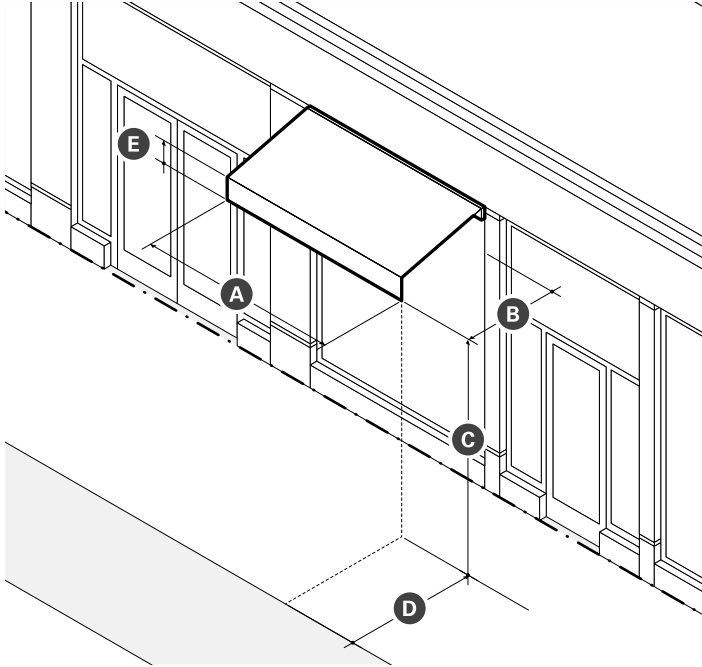

Dimensions	
<b>A</b> Width (min)	See §X
<b>B</b> Projection (min)	3 ft
<b>C</b> Clearance (min)	8 ft clear
<b>D</b> Setback from Curb (min)	1.5 ft
<b>E</b> Valance Height (max)	12 in

- ii. Standards
  - a). Awnings must be securely attached to and supported by the building and must fit the windows or doors the awning is attached.
  - b). An awning must be made of durable, weather-resistant material that is water repellent.
  - c). Internally illuminated or back-lit awnings are prohibited.
  - d). An awning that projects over the sidewalk of a public thoroughfare requires compliance with all City Ordinances.

## E. Entry Canopy

- i. An entry canopy is a wall-mounted structure that provides shade and weather protection over the entrance of a building.

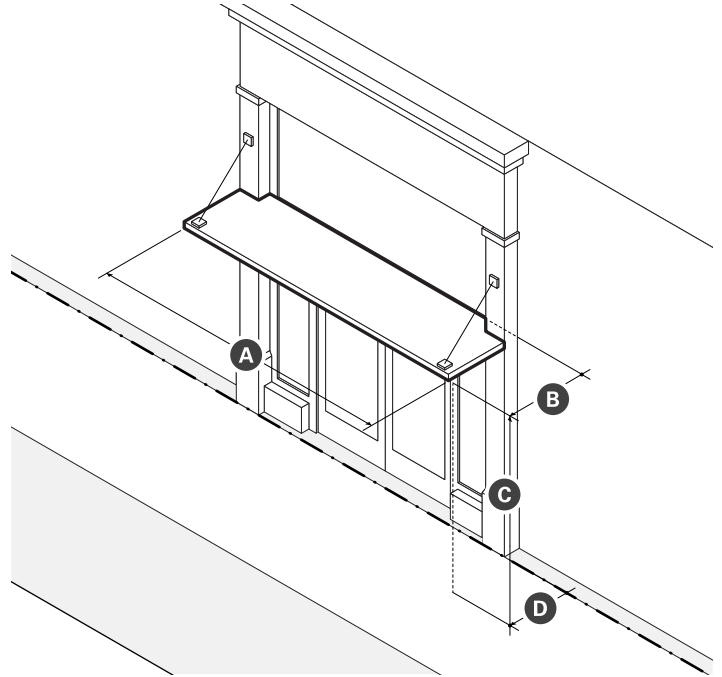

Dimensions	
<b>A</b> Width (min)	See §X
<b>B</b> Depth (max)	3 ft
<b>C</b> Clearance (min)	8 ft clear
<b>D</b> Permitted Setback Encroachment (max)	100%

- ii. Standards
  - a). Entry canopies must be visually supported by brackets, cables, or rods.
  - b). The width of an entry canopy must be equal to or greater than the width of the doorway surround or exterior casing it is mounted over.

## F. Bay

- i. A bay is a window assembly extending from the main body of a building to permit increased light, provide multi-direction views, and articulate a building's facade.

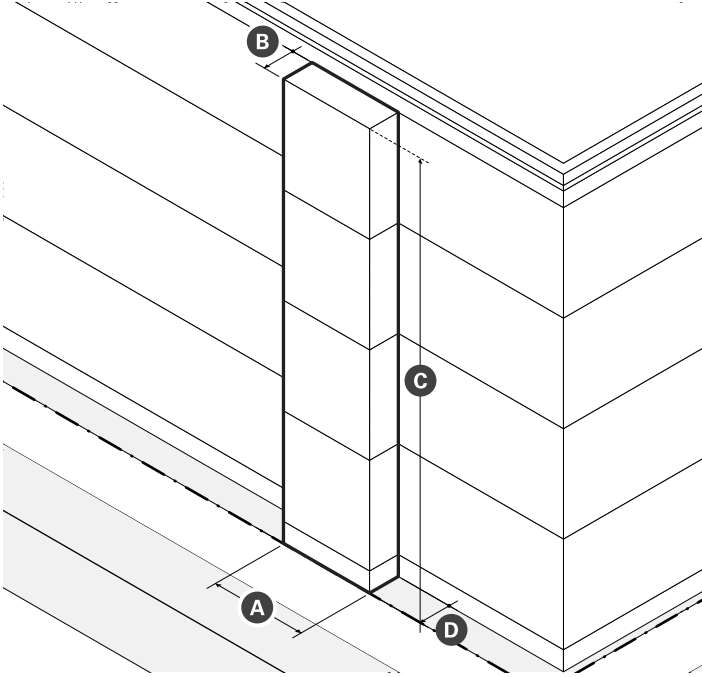

Dimensions	
<b>A</b> Width (min)	50% of facade or elevation
<b>B</b> Depth (max)	3 ft
<b>C</b> Height (max)	Height of Building
Fenestration (min)	60%
<b>D</b> Permitted Setback Encroachment (max)	3 ft

- ii. Standards
  - a). Bays must have a foundation extending all the way to ground level or be visually supported by brackets or other architectural supports.
  - b). Bays projecting over the sidewalk of a public thoroughfare must have two (2) stories of clearance and compliance with all City Ordinances.

## G. Balcony

- i. A balcony is a platform with a railing that provides outdoor amenity space.

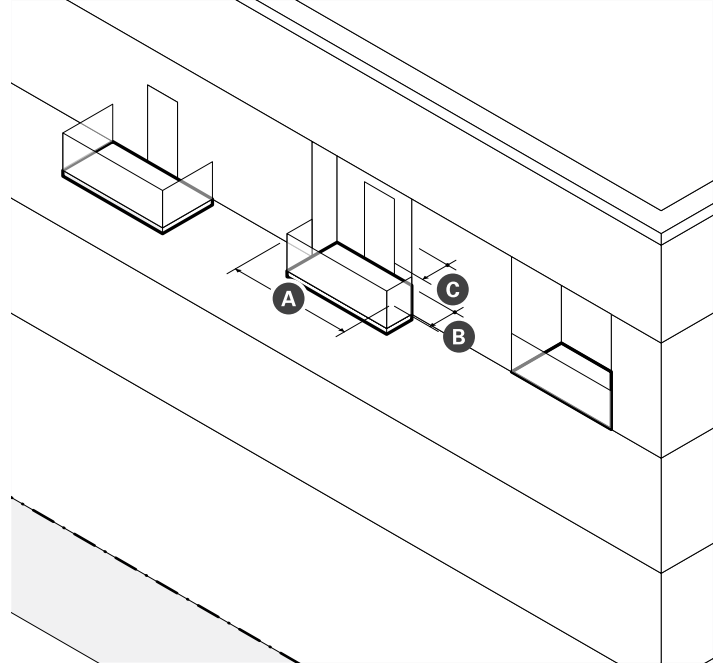

Dimensions	
<b>A</b> Width (min)	5 ft
<b>B</b> Depth (max)	5 ft
Area (min)	50 ft
Clearance (min)	10 ft
<b>C</b> Permitted Front Setback Encroachment (max)	6 ft

- ii. Standards
  - a). Balconies may be recessed, projecting, a combination of the two, or terraced as part of the roof of a portico, porch, or bay.
  - b). A balcony that projects over the sidewalk of a public thoroughfare requires compliance with all City Ordinances.
  - c). The guard rail of any balcony oriented toward a front lot line must permit visual supervision of the public realm through the posts and rails.
  - d). The guard rail of any balcony oriented toward a side or rear lot line abutting the NR district must include sight obscuring visual screening so that it is at least fifty percent (50%) opaque.

# 5. HIGH-RISE DISTRICTS

High-Rise (HR)

## 13. Private Frontages

- a. Private frontage must be designed as one (1) or more frontage types.
- b. Frontage types facilitate access to principal entrances and serve as the interface and transition between the private realm (building interiors) and the public realm (sidewalks and civic spaces).
- c. Frontage types are permitted according to Table 5.1 (b).
- d. Frontage types may be combined as specified for each type and multiple frontage types may exist for buildings that have more than one principal entrance.

**TABLE 5.1 (b) HR Frontage Types**

	Stoop	Lightwell	Dooryard	Forecourt	Lobby Entrance	Storefront	Terrace	Arcade	Specific Standards
General Building	N	N	N	P	P	P	P	P	§X
Commercial Building	N	N	N	P	P	P	P	P	§X
Lab Building	N	N	N	P	P	P	P	P	
Mid-Rise Podium Tower	N	N	N	N	P	P	P	P	
Block Building	N	N	N	P	P	P	P	P	

P - Permitted      SP - Special Permit Required      N - Not Permitted

## E. Stoop

- i. A stoop is a frontage type featuring a set of stairs with a landing leading to the entrance of a building.

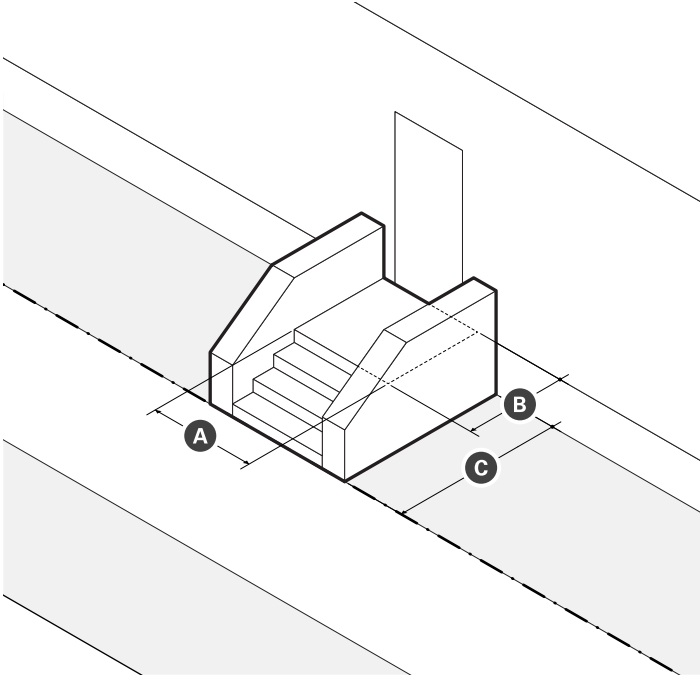

Dimensions	
<b>A</b> Landing Width (min)	4 ft
<b>B</b> Landing Depth (min)	4 ft
<b>C</b> Permitted Front Setback Encroachment (max)	100%

- ii. Standards
  - a). Paving, excluding driveways, must match the abutting sidewalk unless paved with pervious, porous, or permeable materials.
  - b). Stairs may be recessed into the building facade when the building is setback four (4) feet or less.
  - c). Stairs are not permitted to encroach onto any abutting sidewalk.
  - d). Stairs may be built perpendicular or parallel to the building facade, but must lead directly to ground level or an abutting sidewalk.

## F. Lightwell

- i. A frontage type featuring a sunken ground level to allow light and often access into basement levels or to accommodate a change in grade at the front of a building.

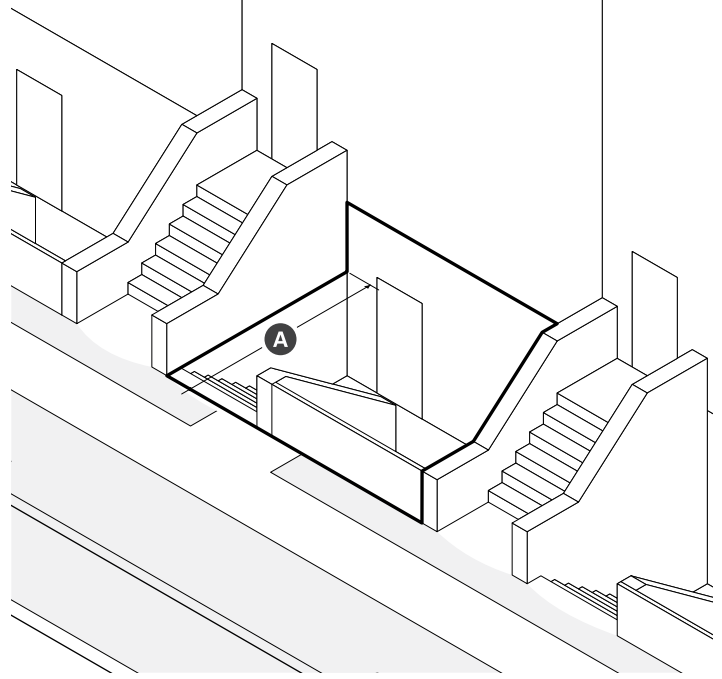

Dimensions	
<b>A</b> Depth (min)	4 ft
Fenestration (min)	--
Residential Uses	30%
Commercial Uses	50%

- ii. Standards
  - a). The principal entrance to upper stories must be provided at the ground story, rather than the basement.
  - b). An entrance to the basement is permitted on the below grade portion of the facade.
  - c). Below grade spaces are required to have windows and doors with highly transparent, low reflectivity glass.
  - d). A short fence is required at the front the sunken portion of the lot.

# 5. HIGH-RISE DISTRICTS

High-Rise (HR)

## G. Dooryard

- i. A dooryard is a frontage type featuring fenced or elevated gardens or patios that buffer dwellings from an adjacent sidewalk.

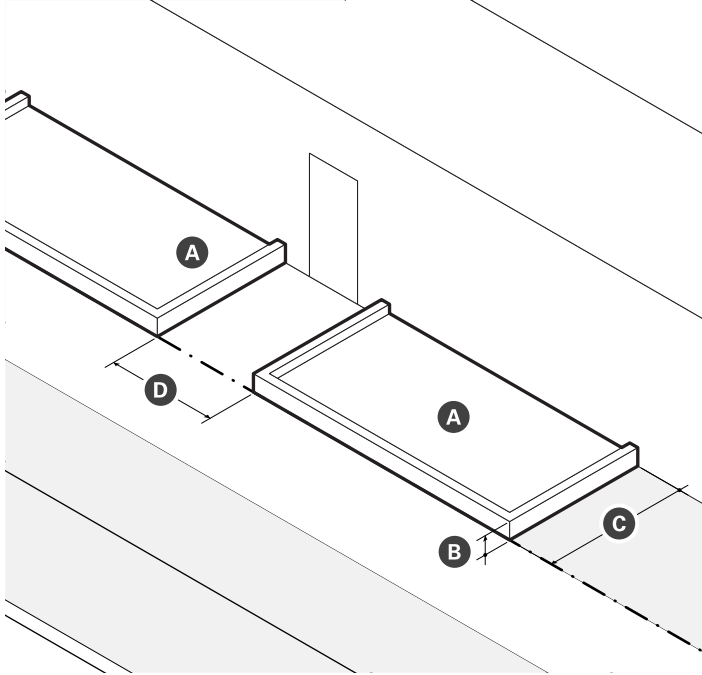

Dimensions	
<b>A</b> Landscaped Area (min)	4 ft
<b>B</b> Elevation above Sidewalk (min)	6 in
<b>C</b> Depth (min)	8 ft
<b>D</b> Path of Travel (min)	3 ft

- ii. Standards
  - a). Dooryards are an appropriate frontage type for a zero-step, accessible entrance, but may include steps leading to the entrance of the building.
  - b). Paving, excluding driveways, must match the abutting sidewalk unless paved with permeable paving.
  - c). A curb or retaining wall that is no taller than structurally necessary may be built around the planter, garden, terrace, or otherwise landscaped area.
  - d). Circulation between adjacent dooryards is prohibited.

## H. Forecourt

- i. A forecourt is a frontage type featuring a landscaped semi-public area, open to the sky, formed by a recess in a central portion of a buildings facade.

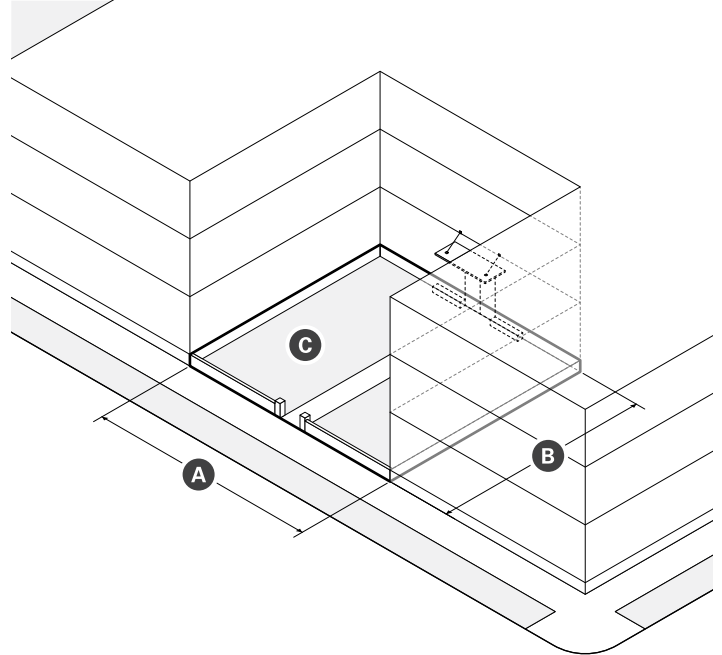

Dimensions	
<b>A</b> Width (min)	12 ft
<b>B</b> Depth (min)	12 ft
Height to Width Ratio (max)	2 to 1
<b>C</b> Landscaped Area (min)	30%

- ii. Standards
  - a). Paving, excluding driveways, must match the abutting sidewalk unless paved with permeable paving.
  - b). Forecourts are considered part of the building for the purpose of measuring facade build out.
  - c). A forecourt must be enclosed by walls on three sides.
  - d). Porches, stoops, porticos, entry canopies, and balconies may encroach into the forecourt.
  - e). Driveways, parking spaces, passenger drop-offs, garage entrances, loading and service areas, exhaust vents, mechanical equipment, and refuse or recycling storage are not permitted in forecourts.

## I. Lobby Entrance

- i. A lobby entrance is a frontage type featuring a non-load bearing assembly of entry doors and windows providing access and light to the lobby of a building.

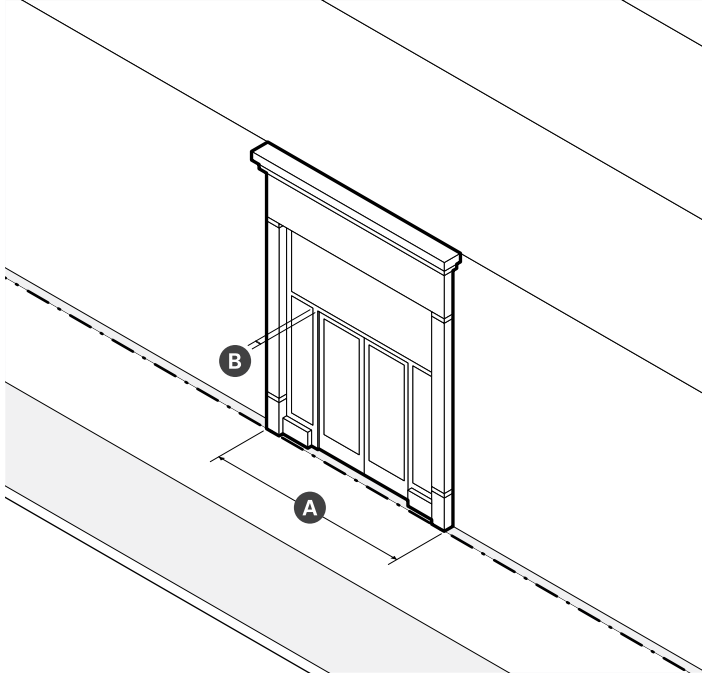

Dimensions	
<b>A</b> Width (max)	30 ft
<b>B</b> Ancillary Column Width (max)	2 ft
Depth of Recessed Entry (max)	5 ft

- ii. Standards
  - a). Lobby entrances must be well-defined, clearly visible, and universally accessible from the abutting sidewalk.
  - b). When a lobby entrance is setback from the front lot line, the frontage must be paved to match the abutting sidewalk.

## J. Storefront

- i. A storefront is a frontage type featuring a non-load bearing assembly of commercial entry doors and substantial windows for the display of goods, services, and signs.

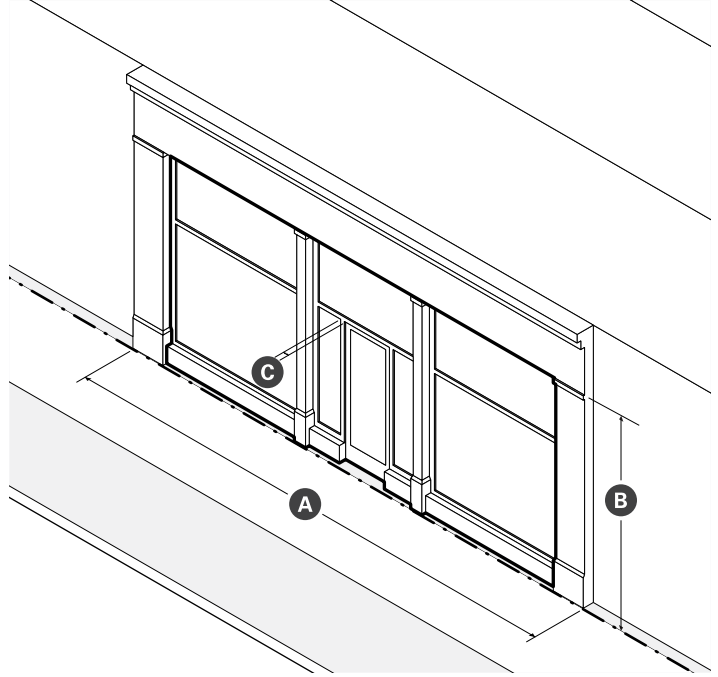

Dimensions	
<b>A</b> Width (max)	30 ft
<b>B</b> Ancillary Column Width (max)	3 ft
<b>C</b> Distance between Fenestration (max)	2 ft
Recessed Entrance Depth (max)	5 ft

- ii. Standards
  - a). An unobstructed view of the interior space or a lighted and maintained merchandise display(s) must be provided for a depth of at least four (4) feet behind storefront display windows.
  - b). The principal entrance of a storefront must be a glass panel door centered between or set to one side of the display windows.
  - c). Recessed entrances may be no wider than fifteen (15) feet per individual entry.
  - d). When storefronts are setback from the front lot line, the ground must be paved to match the abutting sidewalk.
  - e). When present, awnings and canopies must be mounted between columns, pilasters, or piers; above doorways and display windows; and below the sign band.
  - f). Security grills, gates, and roll-down security doors and windows are prohibited.

# 5. HIGH-RISE DISTRICTS

High-Rise (HR)

## K. Terrace

- i. A terrace is a frontage type featuring an elevation of the ground level to accommodate a change in grade that provides circulation and access along the front of a building.

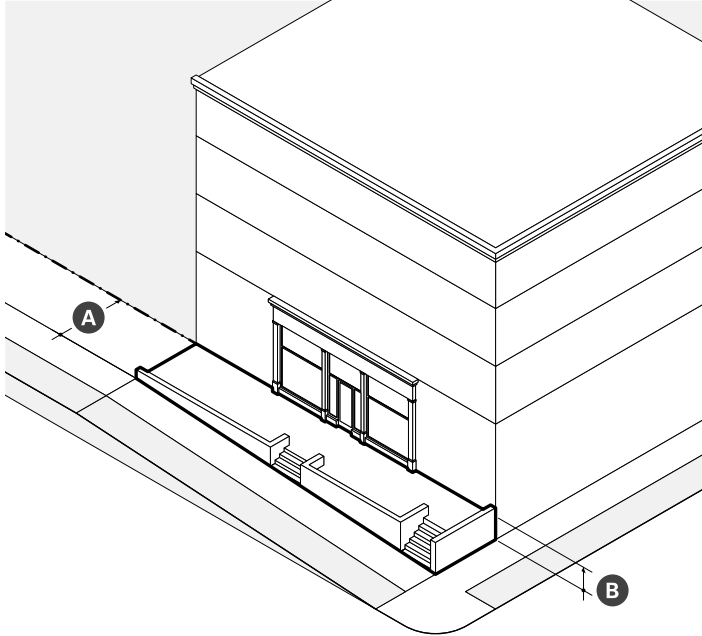

Dimensions	
<b>A</b> Depth (min)	20 ft
<b>B</b> Finish above Sidewalk (min/max)	18 in   4 ft
Distance between Stairs (max)	50 ft

- ii. Standards
  - a). Terrace frontage must be paved to match the abutting sidewalk.
  - b). Frequent steps up to the terrace are required to avoid blank wall along the sidewalk and maximize pedestrian access.

## L. Arcade

- i. An arcade is a frontage type featuring a pedestrian walkway covered by the upper floors of a building. The ground story facade is setback and upper floors are supported by a colonnade or supports.

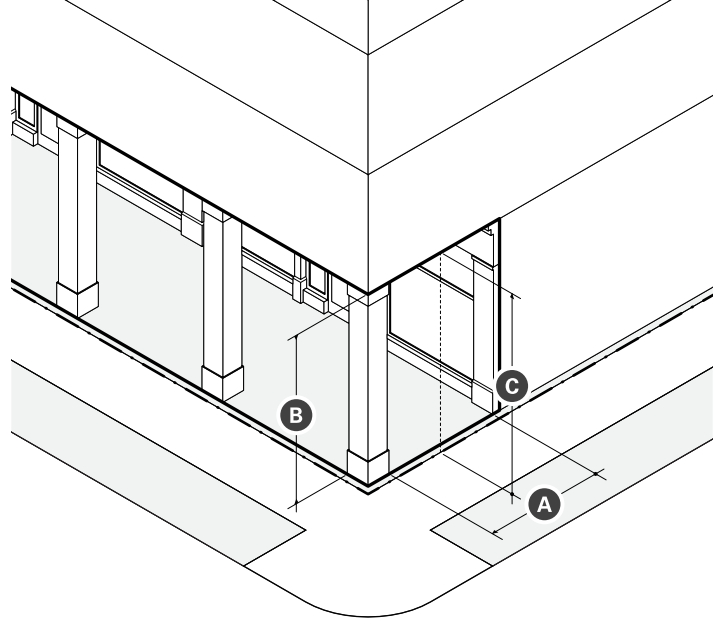

Dimensions		
<b>A</b> Depth (min/max)	10 ft	15 ft
<b>B</b> Height (max)	1 story	
<b>C</b> Clearance (min/max)	14 ft	24 ft

- ii. Standards
  - a). Arcades must extend the entire width of a building and must have a consistent depth.
  - b). Support columns or piers may be spaced no farther apart than they are tall.
  - c). Arcades are considered part of the building for the purpose of measuring facade build out.
  - d). Arcades may be combined only with storefront and lobby entrance frontages.
  - e). The finished ceiling of an arcade interior may be arched or flat, but must have a greater clearance than the openings between columns or piers.



## 14. Building Design Standards

- a. Pedestrian Circulation
  - i. When development occurs on any lot abutting a thoroughfare where the sidewalk is less than twelve (12) feet in total width, the building must be setback an additional distance to accommodate expansion of the abutting sidewalk to a width of at least twelve (12) feet. The minimum and maximum front setbacks for each building type are increased accordingly.
- b. Facade Design
  - i. All building facades must provide surface relief through the use of balconies, Bays, cladding, columns, corner boards, cornices, door surrounds, moldings, piers, pilasters, sills, sign bands, windows, and other architectural features that either recess or project from the average plane of the facade by at least four (4) inches.
  - ii. Vents, exhausts, and other utility features on building facades must be architecturally integrated into the design of the building.
  - iii. Building facades, excluding apartment buildings, must provide a frame for each storefront and lobby entrance in accordance with the following architectural techniques:
    - a). A horizontal lintel or beam (architrave) and cornice that extends across the full width of the building and is supported by columns, pilasters, or piers; or
    - b). A horizontal beam or fascia (architrave) positioned between columns, pilasters, or piers that extend from the upper stories of a building all the way to the ground.
  - iv. When present, a horizontal lintel, beam, or fascia (architrave) serves as the sign band for each storefront.
- c. Towers
  - i. The separation distance between all towers must be at least eighty (80) feet, measured from the exterior walls and excluding balconies.
  - ii. The separation distance between towers may be decreased to a minimum of fifty (50) feet by Special Permit through the use of creative architectural solutions such as offset towers/ views, non-parallel walls, or tapering/curved tower forms, that increase the actual or perceived tower separation distance, provided that both privacy and natural light are provided and no adverse environmental conditions are created.
  - iii. In its discretion to approve or deny a Special Permit authorizing a decrease in tower separation below the standard eighty (80) foot minimum, the Review Board shall consider the following:
    - a). The review considerations for all Special

- Permits (see Section 5.1 Special Permits);
- b). View corridors from windows of new and existing towers;
- c). The effectiveness of architectural techniques to increase the actual or perceived tower separation distance.

## 15. Architectural Design Guidelines

- a. In the absence of any official architectural design guidelines adopted by the Planning Board, the following shall inform the Design Review process for all development within the High-Rise district.
  - i. Facade Articulation
    - a). Building facades should be vertically articulated with Architectural Bays to visually break down and minimize the apparent mass of buildings, shorten the perception of distance/length, provide structure to the composition and disposition of fenestration, enhance pedestrian orientation, and add visual interest to the public realm.
    - b). Architectural bays should be derived, in general, from the building's structural bay spacing.
    - c). Architectural bays should have buttresses, pilasters, columns, or piers that extend either all the way to the ground or to the cornice and sideband of ground level storefronts.
    - d). Architectural bays should align, in general, with individual or groups of storefront and lobby entrance frontages of the ground story of a building.
    - e). In most circumstances, the vertical buttresses, pilasters, columns, or piers of Architectural Bays should always project further and be uninterrupted by any horizontal elements of a facade, excluding the cornice, band, or other architectural feature(s) used to differentiate ground level storefronts from upper stories.
  - ii. Fenestration
    - a). Fenestration should align vertically within each architectural bay and horizontally across each story of a building.
    - b). Upper stories should have a window to wall area proportion that is lower than that of the ground floor.
    - c). Windows should be punched into walls and glass should be inset from exterior wall surfaces.
    - d). Series of windows set side by side to form a continuous horizontal band across a facade (aka 'ribbon windows') should be avoided.
    - e). Solid wall materials should be used to frame groups of windows to reduce the perceived

# 5. HIGH-RISE DISTRICTS

## High-Rise (HR)

- scale of a building.
- iii. Materials
  - a). The palette of wall materials and colors used for a building should be kept to a minimum, preferably three. Similar wall materials as found on adjacent or nearby buildings should be used to strengthen district character and provide continuity and unity between buildings of divergent size, scale, and architectural styles.
  - b). Acceptable wall materials include architectural concrete or pre-cast concrete panels, natural or cast stone, curtain wall and heavy gage metal panel, and brick. Value added materials such as natural or cast stone, concrete, glazed or unglazed architectural terracotta, and brick should be used as wall materials where pedestrians closely encounter and interact with buildings.
  - c). Exterior Insulation and Finish Systems (EIFS) should never be used for the base of a building.
  - d). Horizontal or vertical board siding and shingles, whether wood, metal, plastic (vinyl), masonry, or composite materials, should be used only for smaller scale apartment buildings.
  - e). Two or more wall materials should be combined only one above the other. Wall materials appearing heavier in weight should be used below wall materials appearing lighter in weight.
  - f). Building wall materials that are lighter in color, tint, or shade should be used for the lower floors of a building, with materials darker in color, tint, or shade used above.
  - g). If a building's massing and pattern of fenestration is complex, simple or flat wall materials should be used; if a building's massing and pattern of fenestration is simple, walls should include additional texture and surface relief.
  - h). Side and rear building elevations that are visible from the public realm should have a level of trim and finish that is compatible with the facade of the building.

**FIGURE 5.1 (b) Elements of a Storefront**

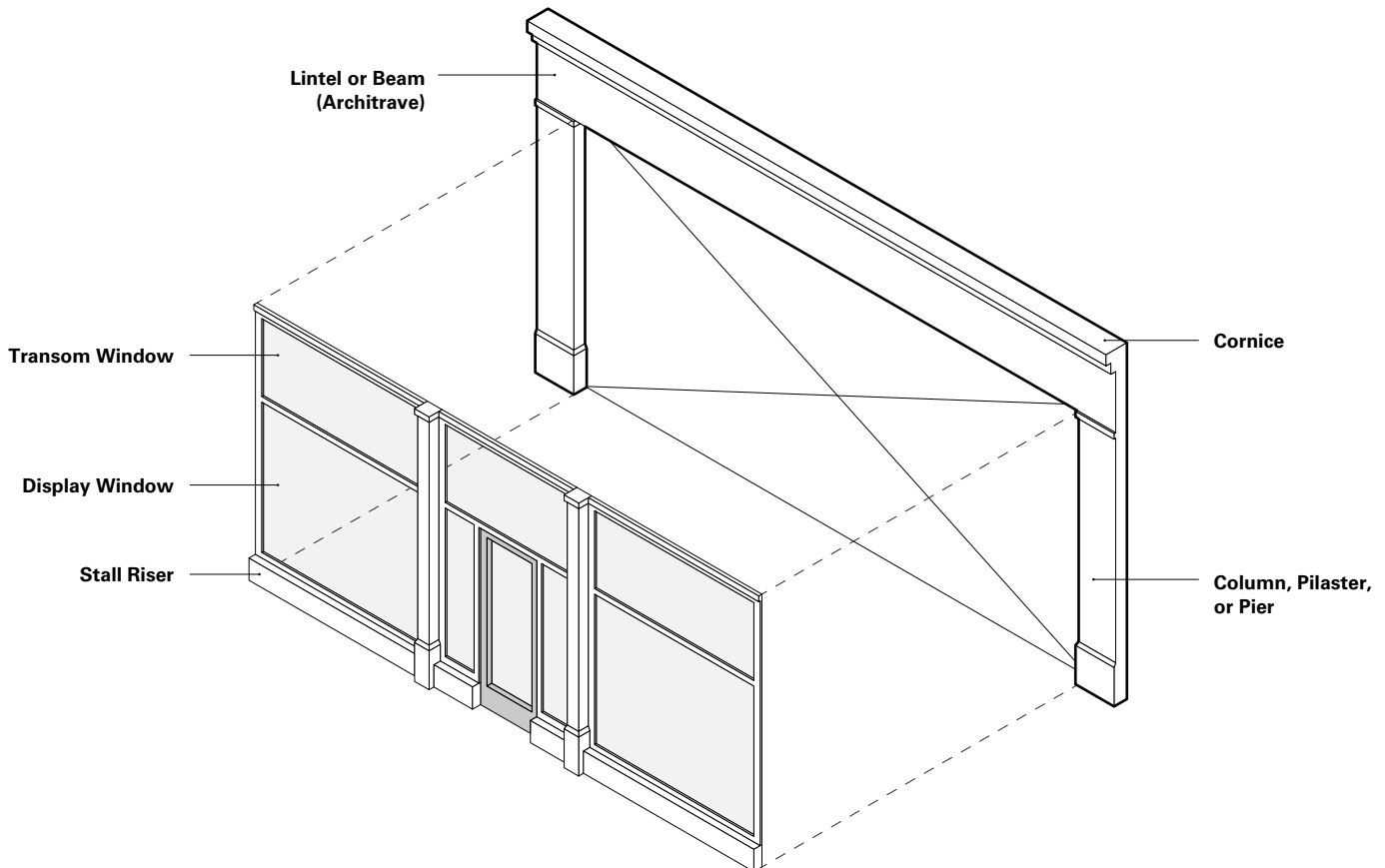

- i). Balconies should have either metal railing or glass guardrail systems.
- iv. Storefronts
  - a). The design of storefronts should invite interaction, enliven the pedestrian environment, and provide a secondary, more intimate source of lighting at night.
  - b). Monotonous and repetitive storefront sign types, and sign designs should be avoided.
  - c). Where a pedestrian street intersects with a side street, commercial spaces should wrap the corner and include at least one storefront on the side street.
  - d). A paneled or rendered stallriser at least one (1) foot in height should be included below display windows.
  - e). Where height permits, transom windows should be included above storefront doors and display windows to allow additional natural daylight to penetrate into the interior space.
  - f). Awnings are encouraged for each storefront to provide weather protection for pedestrians and reduce glare for storefront display areas. Awnings should be open-ended, and operable.
  - g). Bi-fold glass windows and doors and other storefront systems that open to permit a flow of customers between interior and exterior space are encouraged.
- v. Entrances
  - a). Principal entrances should be optimally located, well defined, clearly visible, and universally accessible from the adjacent sidewalk.
  - b). Each ground floor use should have an individual entrance with direct access onto a sidewalk.
  - c). Storefront doors should not obstruct pedestrians walking past or alongside a building.
  - d). Lobby entrances required for upper story uses should be limited in width (frontage) and separate from the entrance for any ground floor uses.
  - e). Features such as a double-height ceiling, distinctive doorway, decorative lighting, recessed facade, or a change in paving material within the setback area should be used to make lobbies for upper story commercial uses distinctive while preserving floor space for other ground floor uses.
- vi. Details
  - a). Architectural details, ornamentation, and articulations should be used with building fenestration to create a harmonious composition that is consistent throughout the building, so that the building appears as a unified whole and not as a collection of unrelated parts that adds to the impression of bulk.
  - b). Exterior lighting (building, storefront, and landscape) should be integrated into the design of the building, create a sense of safety, and encourage pedestrian activity at night through layers of light that contribute to the nighttime experience.
  - c). Exterior lighting should relate to pedestrians and accentuate major architectural or landscape features, but should be shielded to reduce glare and eliminate light being cast into the night sky.
  - d). The upper portions of buildings, especially high-rise buildings, should provide visual interest and a variety in detail and texture to the skyline.
  - e). Mechanical and utility equipment should be integrated into the architectural design of the building or screened from public view. Penthouses should be integrated with the buildings architecture, and not appear as foreign structures unrelated to the building they serve.
  - f). Ventilation intakes/exhausts should be located to minimize adverse effects on pedestrian comfort along the sidewalk and within outdoor spaces.
  - g). Buildings at terminated vistas should be articulated with design features that function as focal points to create memorable views that add to the character and enhance the aesthetics of the neighborhood.

# 5. HIGH-RISE DISTRICTS

High-Rise (HR)

## 16. Use Provisions

- a. General
  - i. The use of real property is subject to the provisions of Article 9.0 Use Provisions of this Ordinance. Where the provisions of this section conflict with those of Article 9.0, the provisions of Article 9.0 apply.
- b. Permitted Uses
  - i. Uses are permitted as specified on Table 5.1 (c). Use categories not expressly authorized are prohibited.
  - ii. All uses must comply with any use-specific standards applicable for each use in §9.2 Use Definitions & Limitations.
  - iii. Uses permitted by Special Permit require additional development review in accordance with §15.2.1 Special Permits.
- c. Use Limitations
  - i. The use of any ground story commercial space fronting a pedestrian street, excluding lobbies for upper story uses, is limited to the following principal use categories:
    - a). Arts & Creative Enterprise
    - b). Eating & Drinking Establishment
    - c). Retail
    - d). Civic & Institutional
- d. Required Uses
  - i. A minimum of five percent (5%) of the gross floor area of any gross leasable commercial floor space in any building must be provided as leasable floor area for uses from the Arts & Creative Enterprise use category.
- e. Increases in Density
  - i. Existing structures may not be altered to conflict with number of dwelling units permitted for each building type.
  - ii. The alteration or renovation of an existing building that results in any increase of the number of dwelling units requires a special permit. See §15.2.1. Special Permit for more information.
    - a). In its discretion to approve or deny a Special Permit authorizing an increase in the number of dwelling units in an existing building, the Review Board shall consider the following:
      - i). the review considerations for all Special Permits as specified in §15.2.1. Special Permit; and
      - ii). the quality of the living space in terms of functional area.

**TABLE 5.1 (c) HR Permitted Uses**

Use Category Specific Use	HR	Use Specific Standards
<b>Arts &amp; Creative Enterprise</b>		
Artisan Production	P	§9.2.2.a
Arts Exhibition	P	§9.2.2.b
Arts Sales & Services	P	§9.2.2.c
Co-working	P	§9.2.2.d
Design Services	P	§9.2.2.e
Shared Workspaces & Arts Education	P	§9.2.2.f
<b>Civic &amp; Institutional</b>		
Community Center	P	§9.2.4.a
Hospital	SP	§9.2.4.b
Library	P	§9.2.4.c
Minor Utility Facility	SP	§9.2.4.d
Museum	P	§9.2.4.f
Private Non-Profit Club or Lodge	SP	§9.2.4.g
Religious & Educational Uses Protected by M.G.L. 40A, Sec. 3	P	§9.2.4.h
<b>Commercial Services</b>		
Animal Services (as noted below)	--	§9.2.5.a
Pet Grooming	P	§9.2.5.a.ii
Veterinarian	SP	§9.2.5.a.iv
Assembly & Entertainment	SP	§9.2.5.b
Banking & Financial Services (except as noted below)	P	§9.2.5.c
Personal Credit	SP	§9.2.5.c.i
Broadcast and/or Recording Studio	P	§9.2.5.d
Building & Home Repair Services	SP	§9.2.5.e
Business Support Services	P	§9.2.5.f
Caterer/Wholesale Food Production	SP	§9.2.5.g
Day Care Service (as noted below)	--	§9.2.5.h
Adult Day Care Center	P	§9.2.5.h.i
Child Day Care Center	P	§9.2.5.h.ii
Educational Institution	P	§9.2.5.i
Maintenance & Repair of Consumer Goods	P	§9.2.5.j
Personal Services (except as noted below)	P	§9.2.5.k
Body-Art Establishment	SP	§9.2.5.k.i
Gym or Health Club	P	§9.2.5.k.ii
Funeral Home	SP	§9.2.5.k.iii

P - Permitted      SP - Special Permit Required      N - Not Permitted

# 5. HIGH-RISE DISTRICTS

High-Rise (HR)

**TABLE 5.1 (c) HR Permitted Uses (continued)**

Use Category Specific Use	HR	Use Specific Standards
Health Care Provider	SP	§9.2.5.k.iv
Recreation Facility	SP	§9.2.5.l
<b>Vehicle Parking, Commercial (except as follows)</b>	--	§9.2.5.m
Bike Share Parking	P	§9.2.5.m.i
Car Share Parking (3 or less spaces)	P	§9.2.5.m.ii
Car Share Parking (4 or more spaces)	P	§9.2.5.m.ii
Public Parking	P	§9.2.5.m.iii
<b>Eating and Drinking</b>		
Bar or Tavern	P	§9.2.6.a
Bakery/Café/Coffee Shop	P	§9.2.6.b
Formula Eating & Drinking Establishment	SP	§9.2.6.c
<b>Lodging</b>		
Bed & Breakfast	SP	§9.2.7.a
Hotel or Hostel	SP	§9.2.7.b
<b>Office</b>		
General Office	P	§9.2.8.a
Research and Development and/or Laboratory	P	§9.2.8.b
<b>Residential</b>		
Household Living	SP	§9.2.9.a
<b>Group Living (except as follows)</b>	SP	§9.2.9.b
Community or Group Residence	P	§9.2.9.b.i
Dormitory, Fraternity or Sorority	SP	§9.2.9.b.ii
Homeless Shelter	SP	§9.2.9.b.iii
Nursing Home/Assisted Living Facility	SP	§9.2.9.b.iv
Rooming House	SP	§9.2.9.b.v
<b>Retail Sales</b>		
Building/Home Supplies & Equipment	SP	§9.2.10.a
<b>Consumer Goods (except as follows)</b>	P	§9.2.10.b
Alcohol Sales	SP	§9.2.10.b.i
Drug Paraphernalia Store	N	§9.2.10.b.ii
Firearms Sales	N	§9.2.10.b.iii
Medical Marijuana	N	§9.2.10.b.iv
Pet Store	SP	§9.2.10.b.v
Formula Retail	SP	§9.2.10.c

P - Permitted      SP - Special Permit Required      N - Not Permitted

**TABLE 5.1 (c) HR Permitted Uses (continued)**

Use Category Specific Use	HR	Use Specific Standards
Fresh Food Market or Grocery Store	P	§9.2.10.d
Farm/Vendor Market	P	§9.2.10.e
<b>Urban Agriculture</b>		
Farming (as noted below)	--	§9.2.11.a
Commercial Farm	P	§9.2.11.a.i
Community Farm	P	§9.2.11.a.ii
Community Gardening	P	§9.2.11.b
<b>Accessory Uses</b>		
Home Occupations (as noted below)	--	§9.2.12.b
Home Office	P	§9.2.12.b.v
Tourist Home	P	§9.2.12.c
Urban Agriculture (as noted below)	--	§9.2.12.d
Apiculture	P	§9.2.12.d.i
Aviculture	P	§9.2.12.d.ii
Commercial Farming	P	§9.2.12.d.iii
Residential Gardening	P	§9.2.12.d.iv

P - Permitted      SP - Special Permit Required      N - Not Permitted

# 5. HIGH-RISE DISTRICTS

High-Rise (HR)

## 17. Vehicular Parking

- a. Parking Standards
  - i. Bicycle and motor vehicle parking must be provided as specified on Table 5.1 (d), except as follows:
    - a). Non-residential uses with five thousand (5,000) square feet or less of gross leasable floor area are exempt from any minimum requirements of Table 5.1 (d).
    - b). Any change in use within a non-residential structure constructed before the effective date of this Ordinance, provided that the change is to a permitted use, is exempt from any minimum requirements of Table 5.1 (d).
  - ii. There are no parking requirements for accessory uses.
  - iii. Motor vehicle parking spaces may be shared between uses on the same lot and buildings on the same block in accordance with §11.3 Shared Parking.
- b. Type
  - i. Motor vehicle parking may be provided as above ground structured parking or underground structured parking.
- c. Unbundled Parking
  - i. Motor vehicle parking spaces must be rented or leased as an option rather than a requirement of the rental, lease, or purchase of a dwelling unit or non-residential floor space.
  - ii. Bicycle parking must be provided at no cost or fee to customers, visitors, employees, tenants, and residents.
- d. Parking Design
  - i. The design of all parking is subject to §11.1 Bicycle Parking and §11.2 Motor Vehicle Parking of this Ordinance.
  - ii. Driveways, curb cuts, and vehicular entrances to parking lots, parking structures, loading docks, and service areas are not permitted along primary front lot lines abutting a pedestrian street, but may provide access from a side street or alley.
  - iii. Driveways may be located within a required side and rear setback areas, but are not permitted between the facade of a building and any front lot line.
  - iv. Driveways may be no more than twenty four (24) feet in width at the frontage.
  - v. Driveways may provide access in whole or in part on or across an abutting lot(s), provided that an access easement exists between all property owners.
  - vi. Unless otherwise specified, only one (1) curb cut is permitted per front lot line.
  - vii. Curb cuts must be located to minimize conflict with pedestrians, bicyclists, and motor vehicles on the thoroughfare they provide access to and from.
  - viii. Curb cuts may be no wider than the driveway or vehicular entrance they serve, excluding flares or returned curbs.
  - ix. Driveway crossings traversing sidewalks with paved furnishing zones must be designed to maintain the grade and clear width of the walkway they cross and must include sloped flares on either side of the driveway apron.
  - x. Driveway crossings traversing sidewalks with continuously planted furnishing zones must be designed to maintain the grade and clear width of the walkway they cross and must include returned

**TABLE 5.1 (d) Vehicular Parking**

\*See Transit Orientation Map for distance to a Transit Station

Use Category Specific Use	BICYCLE		MOTOR VEHICLE	
	Short-Term (min)	Long-Term (min)	Within a Transit Area (max)	Outside of a Transit Area (min)
<b>Arts &amp; Creative Enterprise</b>				
Artisan Production	1 / 10,000 sf	1 / 3,000 sf	1 / 800 sf	1 / 1,000 sf
Arts Exhibition	1 / 10,000 sf	1 / 3,000 sf	1 / 800 sf	1 / 650 sf
Arts Sales & Services	1 / 10,000 sf	1 / 3,000 sf	1 / 200 sf	1 / 1,000 sf
Design Services	1 / 10,000 sf	1 / 3,000 sf	1 / 800 sf	1 / 1,000 sf
Shared Workspaces & Arts Education	1 / 10,000 sf	1 / 3,000 sf	1 / 800 sf	1 / 650 sf

sf - Gross Leasable Square Footage

DU - Dwelling Unit

RU - Rooming Unit



**TABLE 5.1 (d) Vehicular Parking (continued)**

\*See Transit Orientation Map for distance to a Transit Station

Use Category Specific Use	BICYCLE		MOTOR VEHICLE	
	Short-Term (min)	Long-Term (min)	Within a Transit Area (max)	Outside of a Transit Area (min)
<b>Civic &amp; Institutional</b>				
Community Center	1 / 10,000 sf	4 / 10,000 sf	1 / 1,800 sf	1 / 600 sf
Educational Facility	1.0 / classroom	4.0 / classroom	1.5 / classroom	3.0 / classroom
Hospital	10 per entrance	1 / 5,000 sf	1 / 200 sf	1 / 1,000 sf
Library	1 / 3,000 sf	1 / 5,000 sf	1 / 800 sf	1 / 500 sf
Minor Utility Facility	n/a	n/a	n/a	n/a
Museum	1 / 2,000 sf	1 / 10,000 sf	1 / 800 sf	1 / 500 sf
Private Non-Profit Club or Lodge	1 / 2,000 sf	1 / 10,000 sf	1 / 200 sf	1 / 1,000 sf
<b>Commercial Services</b>				
Animal Services (as noted below)	1 / 2,500 sf	1 / 10,000 sf	–	–
Pet Grooming	–	–	1 / 500 sf	1 / 400 sf
Veterinarian	1 / 2,000 sf	1 / 5,000 sf	1 / 500 sf	1 / 500 sf
Assembly & Entertainment	1 / 40 seats	1 / 10,000 sf	1 / 6 seats	1 / 6 seats
Banking & Financial Services (except as noted below)	1 / 2,000 sf	1 / 10,000 sf	1 / 450 sf	1 / 400 sf
Broadcast and/or Recording Studio	1 / 2,500 sf	1 / 10,000 sf	1 / 800 sf	1 / 600 sf
Building & Home Repair Services	1 / 2,500 sf	1 / 10,000 sf	1 / 1,000 sf	1 / 2,000 sf
Business Support Services	1 / 2,500 sf	1 / 10,000 sf	1 / 900 sf	1 / 600 sf
Caterer/Wholesale Food Production	1 / 2,500 sf	1 / 10,000 sf	1 / 800 sf	1 / 1,000 sf
Day Care Service	2	1 / 10,000 sf	1 / 900 sf	1 / 600 sf
Maintenance & Repair of Consumer Goods	1 / 2,500 sf	1 / 10,000 sf	1 / 750 sf	1 / 1,000 sf
Personal Services (except as noted below)	1 / 2,500 sf	1 / 10,000 sf	1 / 750 sf	1 / 1,000 sf
Gym or Health Club			1 / 200 sf	1 / 500 sf
Funeral Home				
Health Care Provider	1 / 2,000 sf	1 / 10,000 sf	1 / 500 sf	1 / 300 sf
Recreation Facility	1 / 2,500 sf	1 / 10,000 sf		
Vehicle Parking	n/a	10 or 1 / 10 motor vehicle spaces	n/a	n/a

sf - Gross Leasable Square Footage

DU - Dwelling Unit

RU - Rooming Unit

# 5. HIGH-RISE DISTRICTS

High-Rise (HR)

**TABLE 5.1 (d) Vehicular Parking (continued)**

\*See Transit Orientation Map for distance to a Transit Station

Use Category Specific Use	BICYCLE		MOTOR VEHICLE	
	Short-Term (min)	Long-Term (min)	Within a Transit Area (max)	Outside of a Transit Area (min)
<b>Eating and Drinking</b>				
Bar/Restaurant/Tavern	1 / 1,000 sf	1 / 5,000 sf	1 / 300 sf	1 / 500 sf
Bakery/Café/Coffee Shop	1 / 1,000 sf	1 / 5,000 sf	1 / 300 sf	1 / 500 sf
Formula Eating & Drinking Establishment	1 / 1,000 sf	1 / 5,000 sf	1 / 300 sf	1 / 500 sf
<b>Lodging</b>				
Bed & Breakfast	1 / 20 rooms	1 / 10 rooms	1 / DU + 1 / 4 guest rooms	1 / DU + 1 / 4 guest rooms
Hotel or Hostel	1 / 20 rooms	1 / 10 rooms	1 / 2 guest rooms	1 / 2 guest rooms
Short Term Rental	1 / 20 rooms	1 / 10 rooms	n/a	n/a
<b>Office</b>				
Co-Working	1 / 20,000 sf	1 / 3,000 sf	1 / 1,200 sf	1 / 800 sf
General Office	1 / 20,000 sf	1 / 3,000 sf	1 / 900 sf	1 / 650 sf
Research and Development and/or Laboratory	1 / 20,000 sf	1 / 5,000 sf	1 / 1,000 sf	1 / 1,000 sf
<b>Residential</b>				
Household Living	0.1 / DU	1.0 / DU	1.0 / DU	1.0 / DU
Group Living (except as follows)	0.05 / room	0.5 / room	–	–
Community or Group Residence				
Dormitory or Chapter House	0.1 / room	0.5 / room	.05 / bed	1.0 / 4 beds
Homeless Shelter			4.0	4.0
Nursing Home/Assisted Living Facility			1 / 6 beds	1 / 6 beds
Single Room Occupancy Housing			1 / 6 beds	1 / 4 beds
<b>Retail Sales</b>				
Building/Home Supplies & Equipment	1 / 2,500 sf	1 / 10,000 sf	1 / 1,000 sf	1 / 1,000 sf
Consumer Goods (except as follows)	1 / 2,500 sf	1 / 10,000 sf	1 / 1,500 sf	1 / 750 sf
Packaged Liquor				
Medical Marijuana				
Pet Store				
Formula Retail	1 / 2,500 sf	1 / 10,000 sf	1 / 1,500 sf	1 / 750 sf
Fresh Food Market or Grocery Store	1 / 1,000 sf	1 / 10,000 sf	1 / 500 sf	1 / 1,500 sf
Farm/Vendor Market	n/a	n/a	n/a	1 / 1,500 sf

sf - Gross Leasable Square Footage

DU - Dwelling Unit

RU - Rooming Unit

- curbs.
- xi. The appearance of any walkway (ie. scoring pattern or special paving) must be maintained across any driveway or alley to indicate that, although a vehicle may cross, the area traversed by a vehicle remains part of the sidewalk.
- e. Parking Location
  - i. Required motor vehicle parking, excluding any required handicapped parking, may be provided off-site as follows:
    - a). The off-site parking must be located within one thousand three hundred and twenty (1,320) feet in walking distance to the lot it will serve, measured from the nearest point of the off-site parking along block faces and walkways to the principal entrance of the use served;
    - b). Pedestrian access to off-site motor vehicle parking must be via a paved sidewalk or walkway.
    - c). A lease, recorded covenant, or other comparable legal instrument guaranteeing long term use of the site must be provided to the review board or building official and executed and filed with the Registry of Deeds.
  - ii. For real property located in more than one municipality, motor vehicle parking need not be located within the City of Somerville.
- f. Parking Relief
  - i. Relief from the parking standards of Table 5.1 (d) requires a special permit.
    - a). In its discretion to approve or deny a special permit authorizing relief from the parking standards of Table 5.1 (d), the review board shall consider the following:
      - i). The supply and demand of on-street parking in the neighborhood, as determined through a parking study.
      - ii). Mobility management programs and services provided by the applicant to reduce the demand for parking.
      - iii). That parking provided in excess of any maximum permitted does not result in the increase in impervious lot area.

## 18. Site Development

- a. General
  - i. Development is subject the provisions of Article 10.0 Development Standards of this Ordinance. Where the provisions of this section conflict with those of Article 5.0, the provisions of Article 10.0 apply.
- b. Signs
  - i. A sign, individual numerals or letters, or a nonelectrical nameplate identifying the property address is required for all real property as follows:
    - a). Each ground story non-residential use must identify the street address either on the principal entrance door or above or beside the principal entrance of the use.
    - b). All residential building types must identify the street address either on the principal entrance door, above or beside the principal entrance, or on a mailbox.
  - ii. Address signs must be made easily visible through the use of colors or materials that contrast with the background material they are attached to and must be conspicuously located to provide visibility from the thoroughfare that the building faces.
  - iii. Address signs must be twelve (12) inches in height or less and may include the name of the occupant.

# 5. HIGH-RISE DISTRICTS

High-Rise (HR)