

## 6 COMMERCIAL DISTRICTS

|   |            |  |            |
|---|------------|--|------------|
| <b>6.1 FABRICATION (FAB) .....</b>        | <b>277</b> | <b>6.4 COMMERCIAL BUSINESS (CB).....</b> | <b>343</b> |
| Description                               | 277        | Character Description                    | 343        |
| Intent                                    | 278        | Intent                                   | 344        |
| Purpose                                   | 278        | Purpose                                  | 344        |
| Applicability                             | 278        | Applicability                            | 344        |
| Development Review                        | 278        | Standards & Measurements                 | 344        |
| Building Types                            | 278        | Development Review                       | 344        |
| Building Components                       | 283        | Building Types                           | 344        |
| Private Frontage                          | 285        | Building Components                      | 357        |
| Building Design Standards                 | 289        | Private Frontage                         | 359        |
| Architectural Design Guidelines           | 290        | Use Provisions                           | 362        |
| Use Provisions                            | 290        | Vehicular Parking                        | 366        |
| Vehicular Parking                         | 292        | Site Development                         | 370        |
| Site Development                          | 294        |  |            |
| <br>                                      |            |  |            |
| <b>6.2 COMMERCIAL CORE (CC) .....</b>     | <b>295</b> |  |            |
| Description                               | 295        |  |            |
| Intent                                    | 296        |  |            |
| Purpose                                   | 296        |  |            |
| Applicability                             | 296        |  |            |
| Development Review                        | 296        |  |            |
| Building Types                            | 296        |  |            |
| Building Components                       | 305        |  |            |
| Private Frontage                          | 307        |  |            |
| Building Design Standards                 | 311        |  |            |
| Architectural Design Guidelines           | 312        |  |            |
| Use Provisions                            | 315        |  |            |
| Vehicular Parking                         | 318        |  |            |
| Site Development                          | 321        |  |            |
| <br>                                      |            |  |            |
| <b>6.3 COMMERCIAL INDUSTRY (CI) .....</b> | <b>323</b> |  |            |
| Description                               | 323        |  |            |
| Intent                                    | 324        |  |            |
| Purpose                                   | 324        |  |            |
| Applicability                             | 324        |  |            |
| Development Review                        | 324        |  |            |
| Building Types                            | 324        |  |            |
| Building Components                       | 329        |  |            |
| Private Frontage                          | 331        |  |            |
| Building Design Standards                 | 333        |  |            |
| Architectural Design Guidelines           | 333        |  |            |
| Use Provisions                            | 335        |  |            |
| Vehicular Parking                         | 338        |  |            |
| Site Development                          | 341        |  |            |

**2ND DISCUSSION DRAFT**



## 6.1 FABRICATION (FAB)

### 1. Description

The Fabrication district is characterized by moderate to large floor plate buildings up to four (4) stories in height. Buildings are set close to the sidewalk to create a defined street wall that supports pedestrian activity and a sense of place. The district is entirely commercial with buildings typically designed or retrofitted to support multiple tenants.

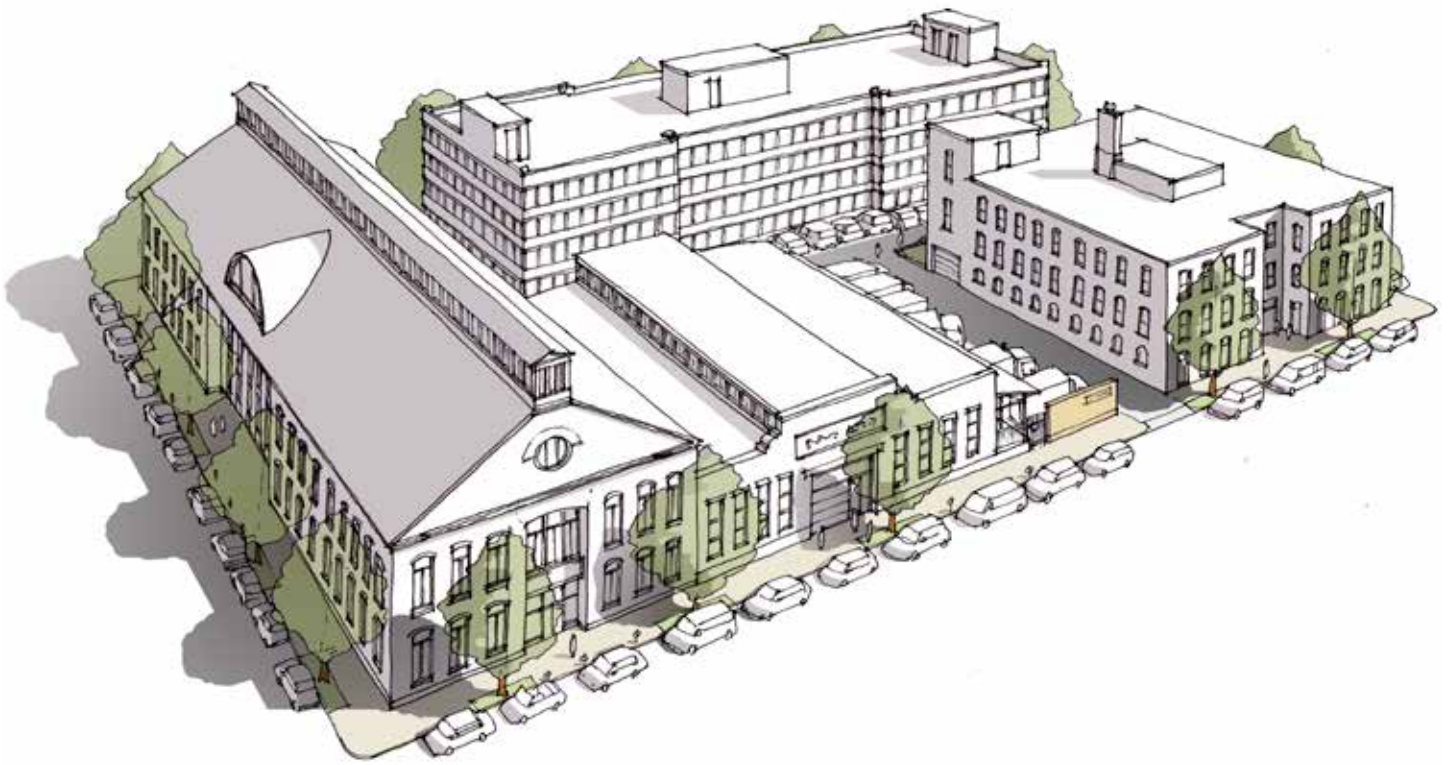

# 6.0 COMMERCIAL DISTRICTS

## Fabrication (FAB)

### 2. Intent

- a. To implement recommendations of SomerVision related to the arts & creative economy.
- b. To protect buildings that are key assets to the creative economy of Somerville from residential conversion, preserve existing work space, and retain incubator spaces for start-up, entry-, and mid-level businesses.
- c. To create, maintain, and enhance areas appropriate for small- and moderate-scale, single- and multi-use buildings; activities common to the arts & creative economy and supporting commercial activities; and a variety of employment opportunities in the arts & creative enterprises.

### 3. Purpose

- a. To permit the development of single- and multi-use buildings that do not exceed four (4) stories in height.
- b. To provide quality commercial spaces and permit a mix of uses common to the arts & creative economy and supporting commercial activities.
- c. To prohibit residential principal uses.

### 4. Applicability

- a. The section is applicable to all real property within the Fabrication district as shown on maps of the Official Zoning Atlas of the City of Somerville.

### 5. Development Review

- a. Development on any lot requires the submittal of a development review application to the Building Official and the issuance of a Zoning Compliance Certificate.
- b. Proposed development may or may not necessitate the need for Site Development Plan Approval, a Special Permit, or a Variance based on the nature of the proposal. In such cases, additional development review is required in accordance with Article 15: Administration.
  - i. The Planning Board is the decision making authority for all development that requires Site Development Plan Approval or a Special Permit.
  - ii. The Zoning Board of Appeals is the Review Board for all Variances.
- c. Upon verification that no additional development review is necessary or completion of the required development review, a Zoning Compliance Certificate shall be issued by the Building Official to certify compliance with the provisions and procedures of this Ordinance.

### 6. Building Types

- a. One (1) principal building type may be built on each lot.
- b. The following building types are permitted by Site Development Plan Approval in the Fabrication district:
  - i. Fabrication Building
- c. Accessory structures are regulated according to Article 10: Development Standards of this Ordinance.



## 7. Fabrication Building

A moderate to large floor plate, multi-story building type typically designed with tall ceilings, expansive windows, wide corridors, service elevators, and loading docks. Fabrication buildings are sometimes naturally lit with a monitor, clerestory, or sawtooth roofs.

The following images are examples of the fabrication building type and are intended only for illustrative purposes.



# 6.0 COMMERCIAL DISTRICTS

Fabrication (FAB)

## 7. Fabrication Building (continued)

### a. Lot Standards

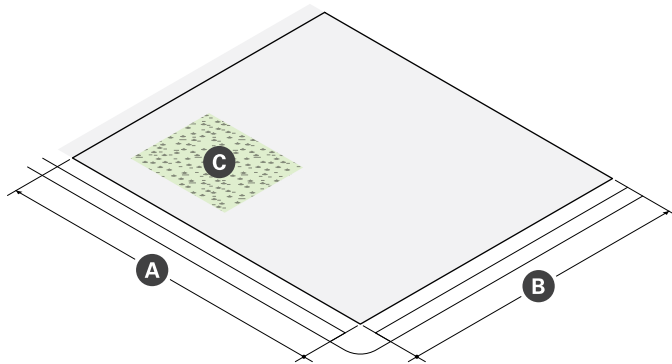

| Lot Dimensions       |       |
|----------------------|-------|
| <b>A</b> Width (min) | 30 ft |

| Lot Coverage                |      |
|-----------------------------|------|
| <b>B</b> Lot Coverage (max) | 100% |
| <b>C</b> Green Factor (min) | 0.20 |

### b. Building Placement

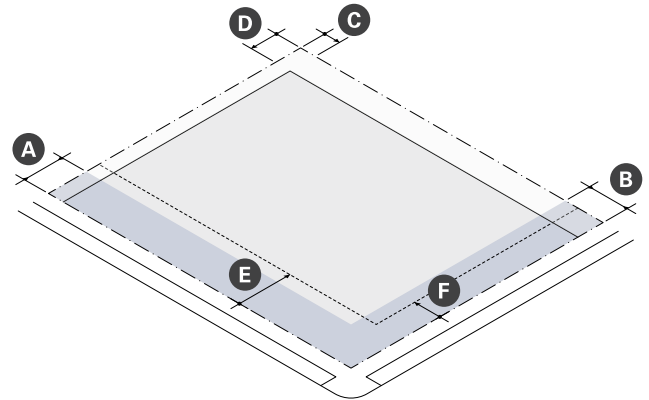

| Building Setbacks                          |       |       |
|--|-------|-------|
| <b>A</b> Primary Front Setback (min/max)   | 10 ft | 20 ft |
| <b>B</b> Secondary Front Setback (min/max) | 10 ft | 20 ft |
| <b>C</b> Side Setback (min)                | 5 ft  |       |
| <b>D</b> Rear Setback (min)                | 20 ft |       |

| Parking Setbacks                       |       |
|--|-------|
| <b>E</b> Primary Front Setback (min)   | 20 ft |
| <b>F</b> Secondary Front Setback (min) | 10 ft |

## 7. Fabrication Building (continued)

c. Height & Massing

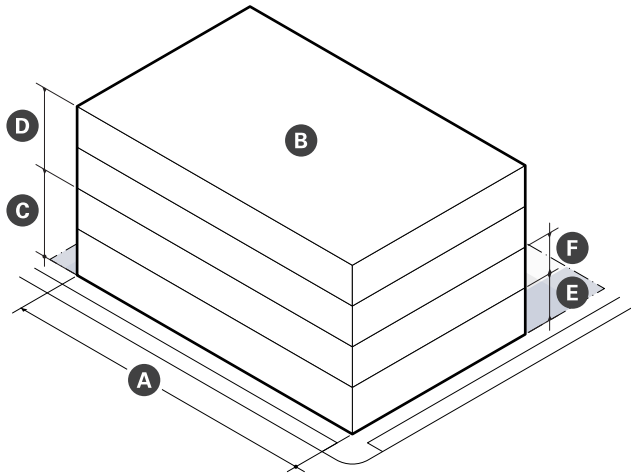

d. Uses & Features

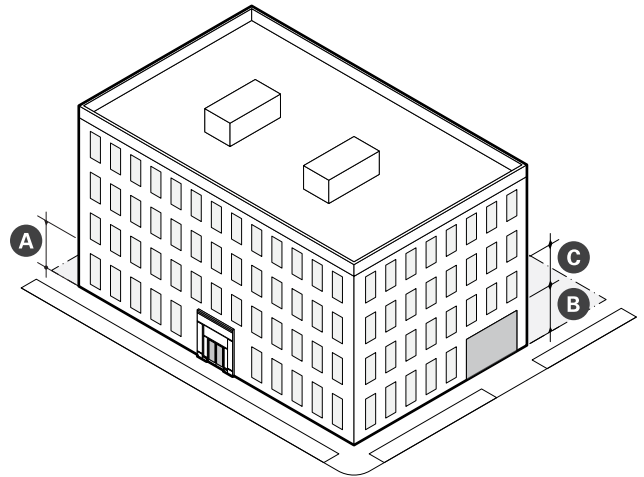

| Main Body                               |           |
|---|-----------|
| <b>A</b> Building Width (max)           | n/a       |
| Facade Build Out                        |           |
| Front Street (min)                      | 65%       |
| Side Street (min)                       | 65%       |
| <b>B</b> Floor Plate (max)              | 30,000 sf |
| <b>C</b> Building Height, Stories (min) | 2 stories |
| <b>D</b> Building Height, Stories (max) | 4 stories |
| <b>E</b> Ground Story Height (min)      | 14 ft     |
| <b>F</b> Upper Story Height (min)       | 10 ft     |
| Building Height, Feet (max)             | 65 ft     |
| Roof Type                               | n/a       |

| Facade Composition                          |         |
|---|---------|
| Ground Story Fenestration (min)             | --      |
| <b>A</b> Front Street                       | 50%     |
| <b>B</b> Side Street                        | 20%     |
| <b>C</b> Upper Story Fenestration (min/max) | 20% 50% |
| Blank Wall (max)                            | 50 ft   |

| Use & Occupancy                     |       |
|-------------------------------------|-------|
| Ground Story Entrance Spacing (max) | n/a   |
| Commercial Space Depth (min)        | 30 ft |

# 6.0 COMMERCIAL DISTRICTS

Fabrication (FAB)

- i. Reserved



## 8. Building Components

- a. Building components are accessory features that increase the habitable square footage or enhance the usefulness of a building.
- b. The following building components are permitted in the Fabrication (FAB) district:
  - i. Awning
  - ii. Entry Canopy
  - iii. Bay
  - iv. Roof Deck
- c. Building components not expressly authorized are prohibited.

## D. Awning

- i. A wall mounted, pitched covering extending from a building to provide shade and weather protection for pedestrians.

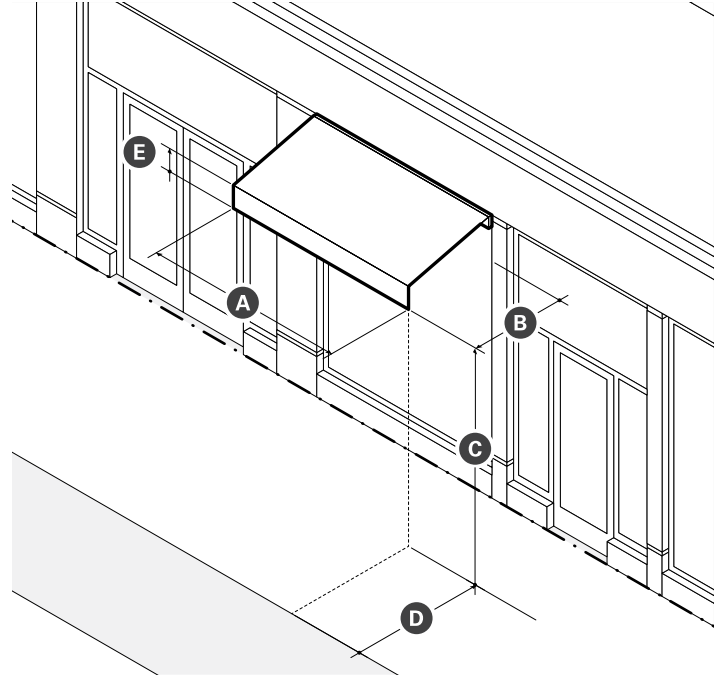

| Dimensions                       |            |
|----------------------------------|------------|
| <b>A</b> Width (min)             | See §X     |
| <b>B</b> Projection (min)        | 3 ft       |
| <b>C</b> Clearance (min)         | 8 ft clear |
| <b>D</b> Setback from Curb (min) | 1.5 ft     |
| <b>E</b> Valance Height (max)    | 12 in      |

- ii. Standards
  - a). Awnings must be securely attached to and supported by the building and must fit the windows or doors the awning is attached to.
  - b). An awning must be made of durable, weather-resistant material that is water repellent.
  - c). Internally illuminated or back-lit awnings are prohibited.
  - d). An awning that projects over the sidewalk of a public thoroughfare requires compliance with all City Ordinances.

# 6.0 COMMERCIAL DISTRICTS

Fabrication (FAB)

## E. Entry Canopy

- i. An entry canopy is a wall-mounted structure that provides shade and weather protection over the entrance of a building.

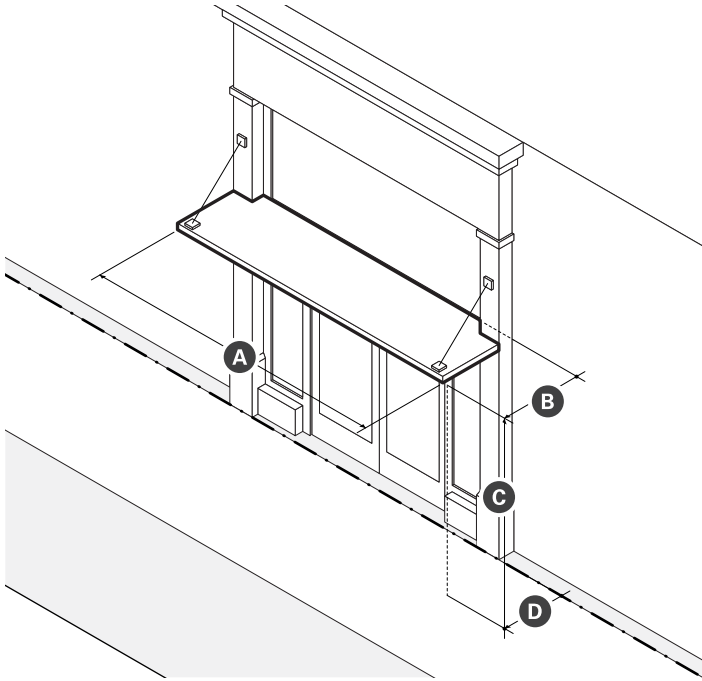

| Dimensions                                    |            |
|---|------------|
| <b>A</b> Width (min)                          | See §X     |
| <b>B</b> Depth (max)                          | 3 ft       |
| <b>C</b> Clearance (min)                      | 8 ft clear |
| <b>D</b> Permitted Setback Encroachment (max) | 100%       |

- ii. Standards
  - a). Entry canopies must be visually supported by brackets, cables, or rods.
  - b). The width of an entry canopy must be equal to or greater than the width of the doorway surround or exterior casing it is mounted over.

## F. Bay

- i. A bay is a window assembly extending from the main body of a building to permit increased light, provide multi-direction views, and articulate a building's facade.

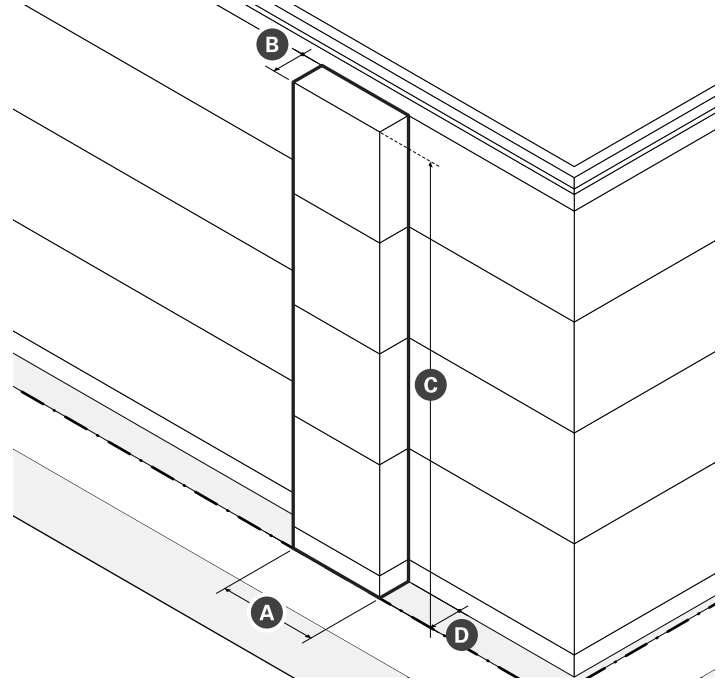

| Dimensions                           |                            |
|--------------------------------------|----------------------------|
| <b>A</b> Width (min)                 | 50% of facade or elevation |
| <b>B</b> Depth (max)                 | 3 ft                       |
| <b>C</b> Height (max)                | Height of Building         |
| <b>D</b> Fenestration (min)          | 60%                        |
| Permitted Setback Encroachment (max) | 3 ft                       |

- ii. Standards
  - a). Bays must have a foundation extending all the way to ground level or be visually supported by brackets or other architectural supports.
  - b). Bays projecting over the sidewalk of a public thoroughfare must have two (2) stories of clearance and compliance with all City Ordinances.

## G. Roof Deck

- i. A roof deck is a roofless, raised platform on the roof of a building that provides outdoor amenity space.

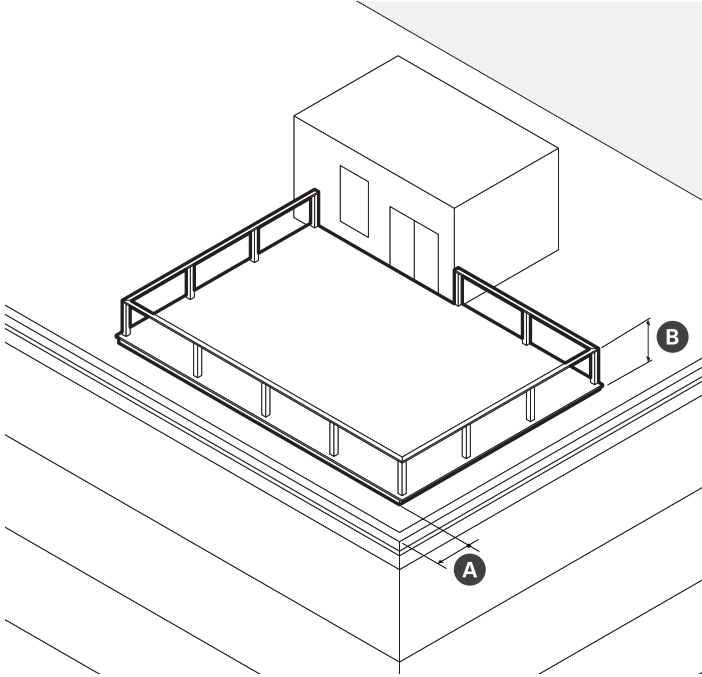

| Dimensions                         |      |
|------------------------------------|------|
| <b>A</b> Setback from Facade (min) | 5 ft |
| <b>B</b> Railing Height (min)      | 4 ft |

- ii. Standards
  - a). Roof decks are only permitted on flat roofs.
  - b). The flooring of a roof deck must be no more than two (2) feet above the roof supporting the deck.
  - c). Roof decks located within five (5) feet of a side rear lot line abutting the NR district must provide sight obscuring visual screening so that it is at least fifty percent (50%) opaque.
  - d). Roof deck access structures, such as stairwell penthouses, may not exceed 10 ft. in height and may only serve to enclose the access stairs.

## 9. Private Frontage

- a. Private frontage must be designed as a building frontage type.
- b. Building frontage types facilitate access to principal entrances and serve as the interface and transition between the private realm (building interiors) and the public realm (sidewalks and civic spaces).
- c. The following building frontage types are permitted in the Fabrication (FAB) district:
  - i. Forecourt
  - ii. Lobby Entrance
  - iii. Storefront
  - iv. Terrace
  - v. Arcade
- d. Building frontage types may be combined as indicated for each type and multiple frontage types may exist for buildings that have more than one principal entrance.

# 6.0 COMMERCIAL DISTRICTS

Fabrication (FAB)

## E. Forecourt

- i. A forecourt is a frontage type featuring a landscaped semi-public area, open to the sky, formed by a recess in a central portion of a building's facade.

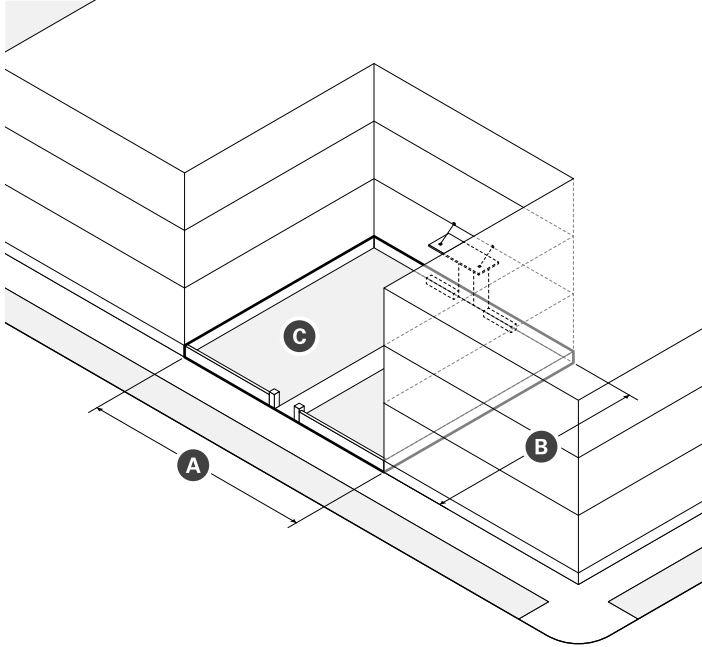

| Dimensions                     |        |
|--------------------------------|--------|
| <b>A</b> Width (min)           | 12 ft  |
| <b>B</b> Depth (min)           | 12 ft  |
| Height to Width Ratio (max)    | 2 to 1 |
| <b>C</b> Landscaped Area (min) | 30%    |

- ii. Standards
  - a). Paving, excluding driveways, must match the abutting sidewalk unless paved with permeable paving.
  - b). Forecourts are considered part of the building for the purpose of measuring facade build out.
  - c). A forecourt must be enclosed by walls on three sides.
  - d). Porches, stoops, porticos, entry canopies, and balconies may encroach into the forecourt.
  - e). Driveways, parking spaces, passenger drop-offs, garage entrances, loading and service areas, exhaust vents, mechanical equipment, and refuse or recycling storage are not permitted in forecourts.

## F. Lobby Entrance

- i. A lobby entrance is a frontage type featuring a non-load bearing assembly of entry doors and windows providing access and light to the lobby of a building.

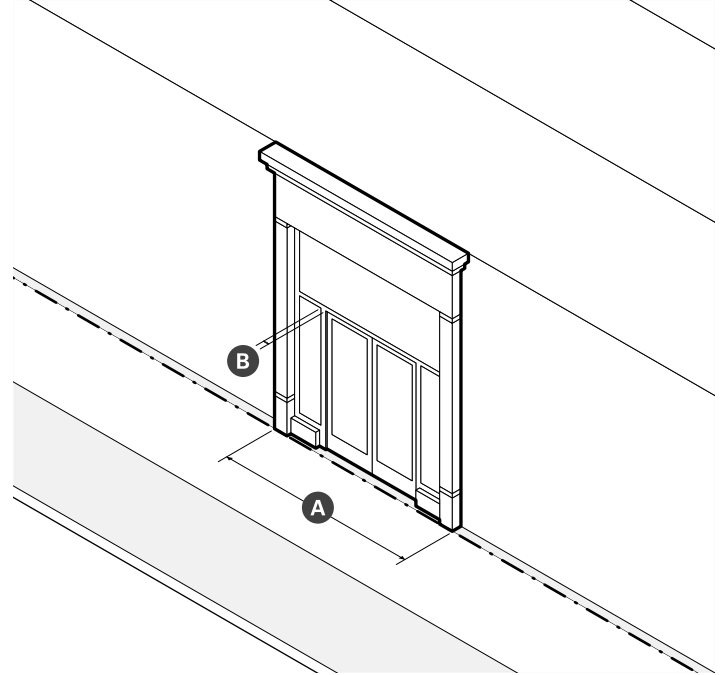

| Dimensions                                   |       |
|--|-------|
| <b>A</b> Width (max)                         | 20 ft |
| <b>B</b> Distance between Fenestration (max) | 2 ft  |
| Depth of Recessed Entry (max)                | 5 ft  |

- ii. Standards
  - a). Lobby entrances must be well-defined, clearly visible, and universally accessible from the abutting sidewalk.
  - b). When a lobby entrance is setback from the front lot line, the frontage must be paved to match the abutting sidewalk.
  - c). Lobby entrances should be made clearly identifiable using a difference in design from the rest of the facade.
  - d). Lobby entrances should include weather protection.

## G. Storefront

- i. A storefront is a frontage type featuring a non-load bearing assembly of commercial entry doors and substantial windows for the display of goods, services, and signs.

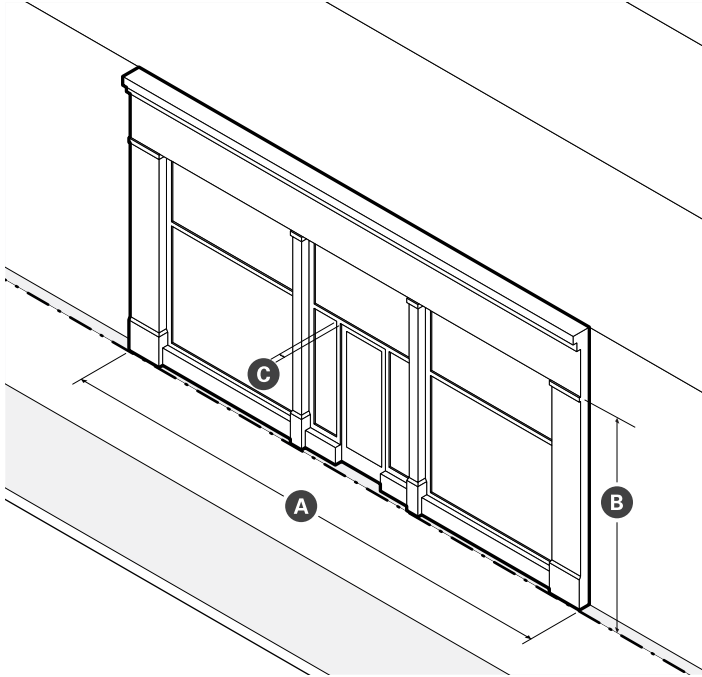

| Dimensions                                   |       |
|--|-------|
| <b>A</b> Width (max)                         | 30 ft |
| <b>B</b> Display Window Height (min)         | 8 ft  |
| <b>C</b> Distance between Fenestration (max) | 2 ft  |
| Depth of Recessed Entry (max)                | 5 ft  |

- ii. Standards
  - a). When storefronts are setback from the front lot line, the frontage must be paved to match the abutting sidewalk.
  - b). Open-ended, operable awnings are encouraged for weather protection.
  - c). Bi-fold glass windows and doors and other storefront systems that open to permit a flow of customers between interior and exterior space are encouraged.

## H. Terrace

- i. A terrace is a frontage type featuring an elevation of the ground level to accommodate a change in grade that provides circulation and access along the front of a building.

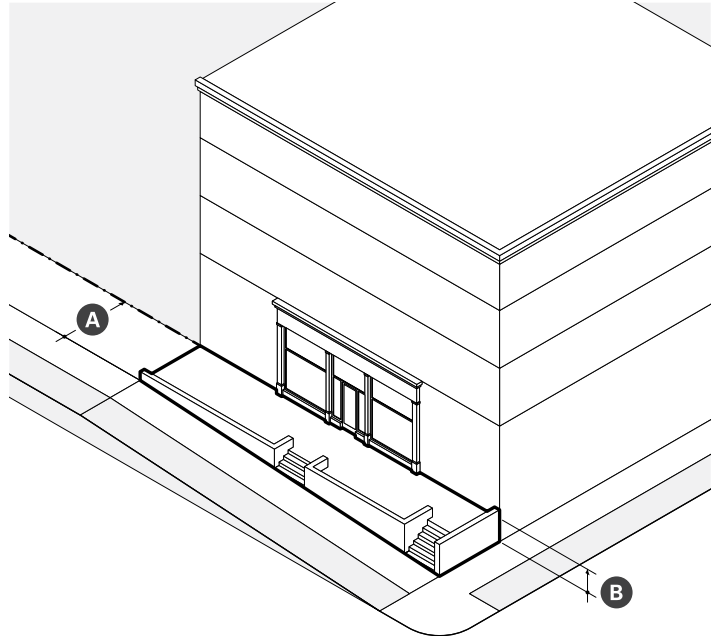

| Dimensions                               |                               |
|--|-------------------------------|
| <b>A</b> Depth (min)                     | 20 ft                         |
| <b>B</b> Finish above Sidewalk (min/max) | 18 in   4 ft                  |
|  | Distance between Stairs (max) |

- ii. Standards
  - a). Terrace frontage must be paved to match the abutting sidewalk.
  - b). Frequent steps up to the terrace are required to avoid blank wall along the sidewalk and maximize pedestrian access.

# 6.0 COMMERCIAL DISTRICTS

Fabrication (FAB)

## I. Arcade

- i. An arcade is a frontage type featuring a pedestrian walkway covered by the upper floors of a building. The ground story facade is setback and upper floors are supported by a colonnade or supports.

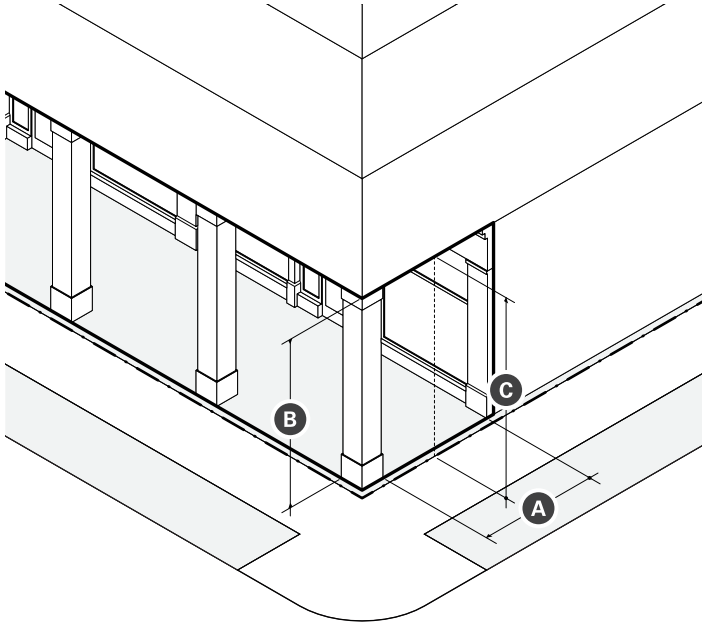

| Dimensions                   |         |       |
|------------------------------|---------|-------|
| <b>A</b> Depth (min/max)     | 10 ft   | 15 ft |
| <b>B</b> Height (max)        | 1 story |       |
| <b>C</b> Clearance (min/max) | 14 ft   | 24 ft |

- ii. Standards
  - a). Arcades must extend the entire width of a building and must have a consistent depth.
  - b). Support columns or piers may be spaced no farther apart than they are tall.
  - c). Arcades are considered part of the building for the purpose of measuring facade build out.
  - d). Arcades may be combined only with storefront and lobby entrance frontages
  - e). The finished ceiling of an arcade interior may be arched or flat, but must have a greater clearance than the openings between columns or piers.



## 10. Building Design Standards

- a. Facade Design
  - i. All facades must provide surface relief through the use of balconies, Bay Windows, cladding, columns, corner boards, cornices, door surrounds, moldings, piers, pilasters, sills, sign bands, windows, and other architectural features that either recess or project from the average plane of the facade by at least four (4) inches.
  - ii. Vents, exhausts, and other utility features on building facades must be architecturally integrated into the design of the building.
- b. Storefronts
  - i. Storefronts must be designed to include, at minimum, columns, pilasters, or piers supporting a proportional fascia or frieze and cornice that serves as a sign band.
    - a). Display windows must extend to at least eight (8) feet above the grade of the Abutting sidewalk.
    - b). A paneled or rendered stallriser at least one (1) foot in height should be included below display windows.
  - ii. windows.
  - iii. The principal entrance of a storefront must be a glass panel door centered between or set to one side of the display windows.
  - iv. Storefront entrances may be recessed up to five (5) feet behind the plane of the facade, provided that the recessed area is no wider than fifteen (15) feet per individual entry.
  - v. Where height permits, transom windows should be included above storefront doors and display windows to allow additional natural daylight to penetrate into the interior space.
  - vi. When present, awnings and canopies must be mounted between storefront columns, pilasters, or piers; above doorway and window openings; and below the fascia/frieze of a storefront sign band.
  - vii. An unobstructed view of the ground story interior space or maintained and lighted merchandise display(s) must be provided for a depth of at least four (4) feet behind the glass of storefront display windows.
  - viii. Security grills, gates, and roll-down security doors

**FIGURE 6.1 (a) Elements of a Storefront**

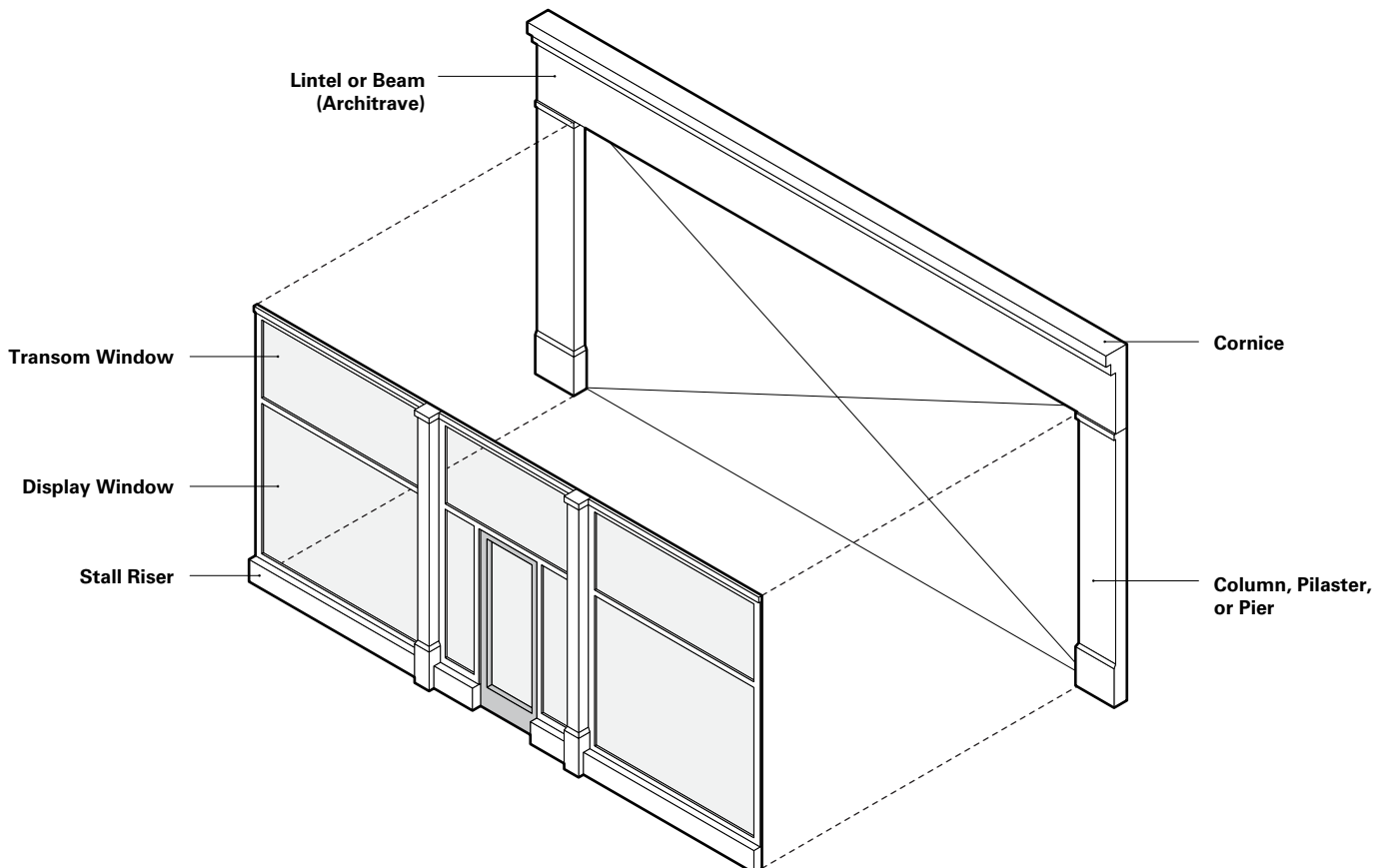

# 6.0 COMMERCIAL DISTRICTS

Fabrication (FAB)

and windows are prohibited.

## 11. Architectural Design Guidelines

- i. Reserved

## 12. Use Provisions

- a. Permitted Uses
  - i. The use of real property is subject to the provisions of Article 9: Use Provisions of this Ordinance. Where the provisions of this section conflict with those of Article 9, the provisions of Article 9 apply.
  - ii. Uses are permitted as specified on Table 6.1. Use categories not expressly authorized are prohibited.
  - iii. All uses must comply with any use-specific standards applicable for each use in §9.2 Use Definitions & Limitations.
  - iv. Uses permitted by Special Permit require additional development review in accordance with §15.2.1 Special Permits.
- b. Use Limitations
  - i. Gross floor area of Manufacturing uses within the Fabrication district is limited to five-thousand (5,000) square feet per establishment.
- c. Required Uses
  - i. A minimum of five percent (5%) of the gross floor area of any Fabrication Building must be provided as leasable floor area for uses from the Arts & Creative Enterprise use category.

**TABLE 6.1 (a) Permitted Uses**

| Use Category<br>Specific Use          | FAB | Use Specific Standards |
|---------------------------------------|-----|------------------------|
| <b>Arts &amp; Creative Enterprise</b> |     |                        |
| Artisan Production                    | P   | §9.2.2.a               |
| Arts Exhibition                       | P   | §9.2.2.b               |
| Arts Sales & Services                 | P   | §9.2.2.c               |
| Co-working                            | P   | §9.2.2.d               |
| Design Services                       | P   | §9.2.2.e               |
| Shared Workspaces & Arts Education    | P   | §9.2.2.f               |
| Work/Live Creative Studio             | SP  | §9.2.2.g               |
| <b>Civic &amp; Institutional</b>      |     |                        |
| Community Center                      | P   | §9.2.4.a               |
| Library                               | P   | §9.2.4.c               |
| Minor Utility Facility                | SP  | §9.2.4.d               |
| Museum                                | P   | §9.2.4.f               |

P - Permitted      SP - Special Permit Required      N - Not Permitted

**TABLE 6.1 (a) Permitted Uses (continued)**

| Use Category<br>Specific Use                                 | FAB | Use Specific<br>Standards |
|--|-----|---------------------------|
| Religious & Educational Uses Protected by M.G.L. 40A. Sec. 3 | P   | §9.2.4.h                  |
| <b>Commercial Services</b>                                   |     |                           |
| Broadcast and/or Recording Studio                            | P   | §9.2.5.d                  |
| Caterer/Wholesale Food Production                            | P   | §9.2.5.g                  |
| Day Care Service (as noted below)                            | --  | §9.2.5.h                  |
| Child Day Care Center  | P   | §9.2.5.h.ii               |
| Educational Institution                                      | P   | §9.2.5.i                  |
| Personal Services (except as noted below)                    | P   | §9.2.5.k                  |
| Body-Art Establishment                                       | P   | §9.2.5.k.i                |
| Gym or Health Club   | N   | §9.2.5.k.ii               |
| Funeral Home   | N   | §9.2.5.k.iii              |
| Health Care Provider   | N   | §9.2.5.k.iv               |
| Recreation Facility  | SP  | §9.2.5.l                  |
| Vehicle Parking, Commercial (except as follows)              | P   | §9.2.5.m                  |
| Bike Share Parking   | P   | §9.2.5.m.i                |
| Car Share Parking (3 or less spaces)                         | P   | §9.2.5.m.ii               |
| Car Share Parking (4 or more spaces)                         | P   | §9.2.5.m.ii               |
| Public Parking   | P   | §9.2.5.m.iii              |
| <b>Industrial</b>  |     |                           |
| Manufacturing  | P   | §9.2.6.c                  |
| <b>Urban Agriculture</b>                                     |     |                           |
| Farming (as noted below)                                     | --  | §9.2.11.a                 |
| Commercial Farm  | P   | §9.2.11.a.i               |
| Community Farm   | P   | §9.2.11.a.ii              |
| Community Gardening  | P   | §9.2.11.b                 |
| <b>Accessory Uses</b>  |     |                           |
| Urban Agriculture (as noted below)                           | --  | §9.2.12.d                 |
| Commercial Farming   | P   | §9.2.12.d.iii             |
| Vehicle Parking, Accessory (except as follows)               | P   | §9.2.12.e                 |
| Home Business Vehicle Parking                                | P   | §9.2.12.f                 |

P - Permitted      SP - Special Permit Required      N - Not Permitted

# 6.0 COMMERCIAL DISTRICTS

## Fabrication (FAB)

### 13. Vehicular Parking

- a. General
  - i. Vehicular parking must be provided as specified on Table 6.1.2, except as follows:
    - a). Non-residential uses with five thousand (5,000) square feet or less of gross leasable floor area are exempt from any minimum requirements of Table 6.1.2.
    - b). Any change in use within a non-residential structure constructed before the effective date of this Ordinance, provided that the change is to a permitted use, is exempt from any minimum requirements of Table 6.1.2.
  - ii. There are no parking requirements for accessory uses.
  - iii. Motor vehicle parking spaces may be shared between uses on the same lot and buildings on the same block in accordance with §12.3 Shared Parking.
- b. Type
  - i. Motor vehicle parking may be provided as above ground structured parking or underground structured parking.
- c. Unbundled Parking
  - i. Motor vehicle parking spaces must be rented or leased as an option rather than a requirement of the rental, lease, or purchase of a dwelling unit or non-residential floor space.
  - ii. Bicycle parking must be provided at no cost or fee to customers, visitors, employees, tenants, and residents.
- d. Parking Design
  - i. The design of all parking is subject to §12.1 Bicycle Parking and §12.2 Motor Vehicle Parking of this Ordinance.
  - ii. Driveways, curb cuts, and vehicular entrances to parking lots, parking structures, loading docks, and service areas are not permitted along primary front lot lines abutting a pedestrian street, but may provide access from a side street or alley.
  - iii. Driveways may be located within a required side and rear setback areas, but are not permitted between the facade of a building and any front lot line.
  - iv. Driveways may be no more than twenty four (24) feet in width at the frontage.
  - v. Driveways may provide access in whole or in part on or across an abutting lot(s), provided that an access easement exists between all property owners.
  - vi. Unless otherwise specified, only one (1) curb cut is permitted per front lot line.
  - vii. Curb cuts must be located to minimize conflict with pedestrians, bicyclists, and motor vehicles on the thoroughfare they provide access to and from.
- e. Parking Location
  - i. Required motor vehicle parking, excluding any required handicapped parking, may be provided off-site according to the following:
    - a). The off-site parking must be located within one thousand three hundred and twenty (1,320) feet in walking distance to the lot it will serve, measured from the nearest point of the off-site parking along block faces and walkways to the principal entrance of the use served;
    - b). Pedestrian access to off-site motor vehicle parking must be via a paved sidewalk or walkway.
    - c). A lease, recorded covenant, or other comparable legal instrument guaranteeing long term use of the site must be provided to the review board or building official and executed and filed with the Registry of Deeds.
  - ii. For real property located in more than one municipality, motor vehicle parking need not be located within the City of Somerville.
- f. Parking Relief
  - i. Relief from the parking standards of Table 6.1.2 requires a special permit.
    - a). In its discretion to approve or deny a special permit authorizing relief from the parking standards of Table 6.1.2, the review board shall consider the following:
      - i). The supply and demand of on-street parking in the neighborhood, as determined through a parking study.
      - ii). Mobility management programs and services provided by the applicant to reduce the demand for parking.
      - iii). That parking provided in excess of any
- viii. Curb cuts may be no wider than the driveway or vehicular entrance they serve, excluding flares or returned curbs.
- ix. Driveway crossings traversing sidewalks with paved furnishing zones must be designed to maintain the grade and clear width of the walkway they cross and must include sloped flares on either side of the driveway apron.
- x. Driveway crossings traversing sidewalks with continuously planted furnishing zones must be designed to maintain the grade and clear width of the walkway they cross and must include returned curbs.
- xi. The appearance of any walkway (ie. scoring pattern or special paving) must be maintained across any driveway or alley to indicate that, although a vehicle may cross, the area traversed by a vehicle remains part of the sidewalk.

**TABLE 6.1 (b) Vehicular Parking**

\*See Transit Orientation Map for distance to a Transit Station

| Use Category<br>Specific Use               | BICYCLE             |                    | MOTOR VEHICLE                     |                                       |
|--|---------------------|--------------------|-----------------------------------|---------------------------------------|
|  | Short-Term<br>(min) | Long-Term<br>(min) | Within a<br>Transit Area<br>(max) | Outside of a<br>Transit Area<br>(min) |
| <b>Arts &amp; Creative Enterprise</b>      |                     |                    | <b>1/4 mile</b>                   |                                       |
| Artisan Production                         | 1 / 10,000 sf       | 1 / 3,000 sf       | 1 / 800 sf                        | 1 / 1,000 sf                          |
| Arts Exhibition                            | 1 / 10,000 sf       | 1 / 3,000 sf       | 1 / 800 sf                        | 1 / 650 sf                            |
| Arts Sales & Services                      | 1 / 10,000 sf       | 1 / 3,000 sf       | 1 / 200 sf                        | 1 / 1,000 sf                          |
| Co-Working                                 | 1 / 20,000 sf       | 1 / 3,000 sf       | 1 / 1,200 sf                      | 1 / 800 sf                            |
| Design Services                            | 1 / 10,000 sf       | 1 / 3,000 sf       | 1 / 800 sf                        | 1 / 1,000 sf                          |
| Shared Workspaces & Arts Education         | 1 / 10,000 sf       | 1 / 3,000 sf       | 1 / 800 sf                        | 1 / 650 sf                            |
| <b>Civic &amp; Institutional</b>           |                     |                    | <b>1/4 mile</b>                   |                                       |
| Community Center                           | 1 / 10,000 sf       | 4 / 10,000 sf      | 1 / 1,800 sf                      | 1 / 600 sf                            |
| Educational Facility                       | 1.0 /<br>classroom  | 4.0 /<br>classroom | 1.5 /<br>classroom                | 3.0 /<br>classroom                    |
| Library                                    | 1 / 3,000 sf        | 1 / 5,000 sf       | 1 / 800 sf                        | 1 / 500 sf                            |
| Minor Utility Facility                     | n/a                 | n/a                | n/a                               | n/a                                   |
| Museum                                     | 1 / 2,000 sf        | 1 / 10,000 sf      | 1 / 800 sf                        | 1 / 500 sf                            |
| Private Non-Profit Club or Lodge           | 1 / 2,000 sf        | 1 / 10,000 sf      | 1 / 200 sf                        | 1 / 1,000 sf                          |
| <b>Commercial Services</b>                 |                     |                    | <b>1/4 mile</b>                   |                                       |
| Broadcast and/or Recording Studio          | 1 / 2,500 sf        | 1 / 10,000 sf      | 1 / 800 sf                        | 1 / 600 sf                            |
| Caterer/Wholesale Food Production          | 1 / 2,500 sf        | 1 / 10,000 sf      | 1 / 800 sf                        | 1 / 1,000 sf                          |
| Day Care Service                           | 2                   | 1 / 10,000 sf      | 1 / 900 sf                        | 1 / 600 sf                            |
| Recreation Facility                        | 1 / 2,500 sf        | 1 / 10,000 sf      |                                   |                                       |
| <b>Industrial</b>                          |                     |                    | <b>1/4 mile</b>                   |                                       |
| Manufacturing                              |                     |                    |                                   |                                       |
| Wholesale Trade & Distribution             |                     |                    |                                   |                                       |
| <b>Office</b>                              |                     |                    | <b>1/4 mile</b>                   |                                       |
| General Office                             | 1 / 20,000 sf       | 1 / 3,000 sf       | 1 / 900 sf                        | 1 / 650 sf                            |
| Research and Development and/or Laboratory | 1 / 20,000 sf       | 1 / 5,000 sf       | 1 / 1,000 sf                      | 1 / 1,000 sf                          |

sf - Gross Leasable Square Footage

DU - Dwelling Unit

## 6.0 COMMERCIAL DISTRICTS

Fabrication (FAB)

maximum permitted does not result in the increase in impervious lot area.

### 14. Site Development

- a. General
  - i. Development is subject the provisions of Article 10: Site Development Standards of this Ordinance. Where the provisions of this section conflict with those of Article 10, the provisions of Article 10 apply.
- b. Signs
  - i. A sign, individual numerals or letters, or a nonelectrical nameplate identifying the property address is required for all real property as follows:
    - a). Each ground story non-residential use must identify the street address either on the principal entrance door or above or beside the principal entrance of the use.
    - b). All residential building types must identify the street address either on the principal entrance door, above or beside the principal entrance, or on a mailbox.
  - ii. Address signs must be made easily visible through the use of colors or materials that contrast with the background material they are attached to and must be conspicuously located to provide visibility from the thoroughfare that the building faces.
  - iii. Address signs must be twelve (12) inches in height or less and may include the name of the occupant.



## 6.2 COMMERCIAL CORE (CC)

### 1. Description

The Commercial Core district is characterized by medium to large floor plate buildings at a variety of heights. Buildings are set close to the sidewalk and taller buildings have an upper story step-back to define a mid-rise street wall that supports pedestrian activity and a sense of place. The district is entirely commercial, with a wide diversity of uses.



# 6.0 COMMERCIAL DISTRICTS

## Commercial Core (CC)

### 2. Intent

- a. To implement recommendations of SomerVision for commercial development.
- b. To create, maintain, and enhance areas appropriate for moderately-scaled single- and multi-use commercial buildings; neighborhood-, community-, and region-serving uses; and a wide variety of employment opportunities.

### 3. Purpose

- a. To permit the development of mid- and high-rise single- and multi-use commercial buildings.
- b. To provide quality ground story commercial spaces and permit small and medium-scale, neighborhood-, community-, and region-serving commercial uses.

### 4. Applicability

- a. The section is applicable to all real property within the Commercial Core district as shown on the Official Zoning Map of the City of Somerville.
- b. The Commercial Core district is a family of sub districts where the CC zone classification is followed by a number associated with the permitted building height on the zoning map.

### 5. Development Review

- a. Development on any lot requires the submittal of a development review application to the Building Official and the issuance of a Zoning Compliance Certificate.
- b. Proposed development may or may not necessitate the need for Site Development Plan Approval, a Special Permit, or a Variance based on the nature of the proposal. In such cases, additional development review is required in accordance with Article 15: Administration.
  - i. The Planning Board is the decision making authority for all development that requires Site Development Plan Approval or a Special Permit.
  - ii. The Zoning Board of Appeals is the Review Board for all Variances.
- c. Upon verification that no additional development review is necessary or completion of the required development review, a Zoning Compliance Certificate shall be issued by the Building Official to certify compliance with the provisions and procedures of this Ordinance.

### 6. Building Types

- a. One (1) principal building type may be built on each lot.
- b. The following building types are permitted by Site Development Plan Approval in the Commercial Core district:
  - i. Commercial Building
    - a). Maximum building heights are limited as follows:
      - i). CC-4: four (4) stories and sixty five (65) feet.
      - ii). CC-5: five (5) stories and seventy five (75) feet.
      - iii). CC-7: seven (7) stories and one hundred and five (105) feet.
  - ii. Lab Building
    - a). Maximum building heights are limited as follows:
      - i). CC-4: four (4) stories and seventy (70) feet.
      - ii). CC-5: five (5) stories and eighty (80) feet.
      - iii). CC-7: seven (7) stories and one hundred and fifteen (115) feet.
- c. Accessory structures are regulated according to Article 10: Development Standards of this Ordinance.

## 7. Commercial Building

A multi-story building type limited to commercial uses on all floors. Ground floor space is primarily occupied by retail or eating & drinking establishment uses rather than lobbies for upper floor uses. Floor space on upper floors is sometimes occupied by retail uses that do not rely on the visibility of a storefront at sidewalk level.

The following images are examples of the commercial building type and are intended only for illustrative purposes.





# 6.0 COMMERCIAL DISTRICTS

Commercial Core (CC)

## 7. Commercial Building (continued)

a. Lot Standards

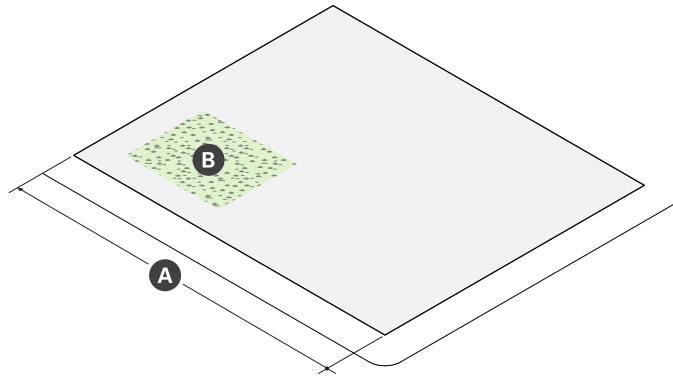

| Lot Dimensions       |       |
|----------------------|-------|
| <b>A</b> Width (min) | 30 ft |

| Lot Coverage                |      |
|-----------------------------|------|
| <b>B</b> Lot Coverage (max) | 100% |
| <b>C</b> Green Factor (min) | 0.20 |

b. Building Placement

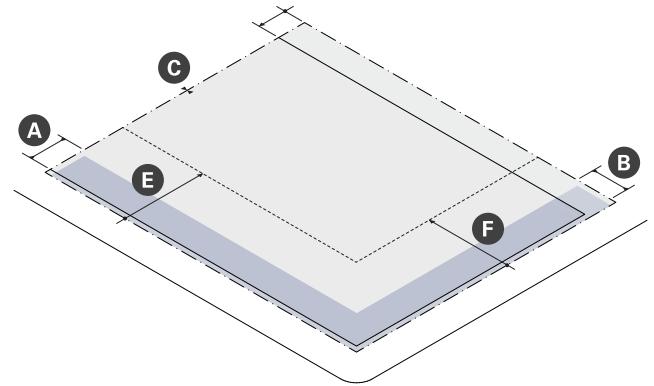

| Building Setbacks                        |       |       |
|--|-------|-------|
| <b>A</b> Primary Front Setback (min/max) | 2 ft  | 15 ft |
| <b>B</b> Secondary Front Setback         | 2 ft  | 15 ft |
| <b>C</b> Side Setback (min)              | 0 ft  |       |
| Side Setback Abutting NR or LHD (min)    | 5 ft  |       |
| <b>D</b> Rear Setback (min)              | 10 ft |       |
| Rear Setback Abutting NR (min)           | 15 ft |       |

| Parking Setbacks                       |       |
|--|-------|
| <b>E</b> Primary Front Setback (min)   | 30 ft |
| <b>F</b> Secondary Front Setback (min) | 30 ft |

## 7. Commercial Building (continued)

### c. Height & Massing

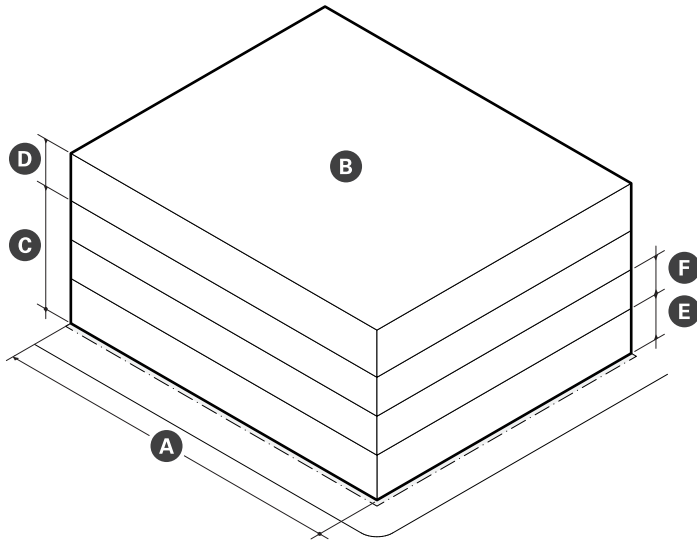

| Main Body                               |                              |
|---|------------------------------|
| <b>A</b> Width (max)                    | 200 ft                       |
| Facade Build Out (min)                  | --                           |
| Primary Frontage                        | 80%                          |
| Secondary Frontage                      | 65%                          |
| <b>B</b> Floor Plate                    | 30,000 sf                    |
| <b>C</b> Building Height, Stories (min) | --                           |
| Primary Frontage                        | 4 stories                    |
| Secondary Frontage                      | 3 stories                    |
| <b>D</b> Building Height (max)          | Varies by CC Map Designation |
| <b>E</b> Ground Story Height (min)      | 14 ft                        |
| <b>F</b> Upper Story Height (min)       | 10 ft                        |

### d. Uses & Features

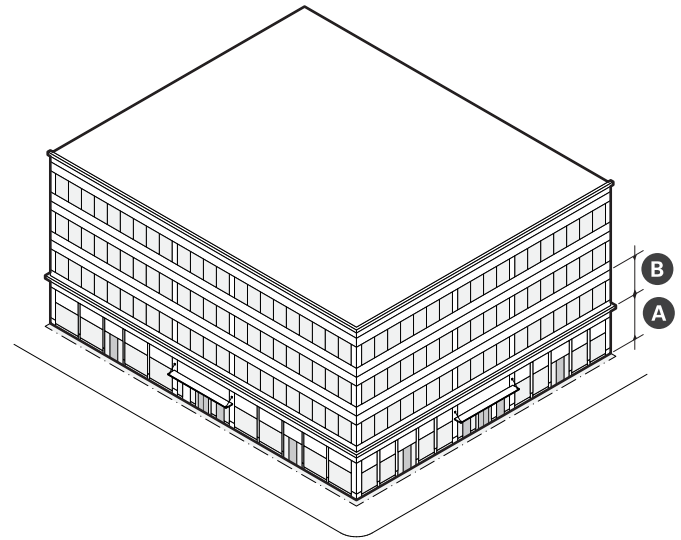

| Facade Composition                          |         |
|---|---------|
| <b>A</b> Ground Story Fenestration (min)    | 70%     |
| <b>B</b> Upper Story Fenestration (min/max) | 20% 70% |
| Blank Wall (max)                            | 20 ft   |

| Use & Occupancy              |       |
|------------------------------|-------|
| Entrance Spacing (max)       | 30 ft |
| Commercial Space Depth (min) | 30 ft |

## 6.0 COMMERCIAL DISTRICTS

Commercial Core (CC)

e. Reserved



## 8. Lab Building

A multi-story building type purpose built for laboratory and research & development uses. Floor space is typically custom designed as complex, technically sophisticated, and mechanically intensive wet or dry labs or vivariums for animal research.

The following images are examples of the lab building type and are intended only for illustrative purposes.



# 6.0 COMMERCIAL DISTRICTS

Commercial Core (CC)

## 8. Lab Building (continued)

### a. Lot Standards

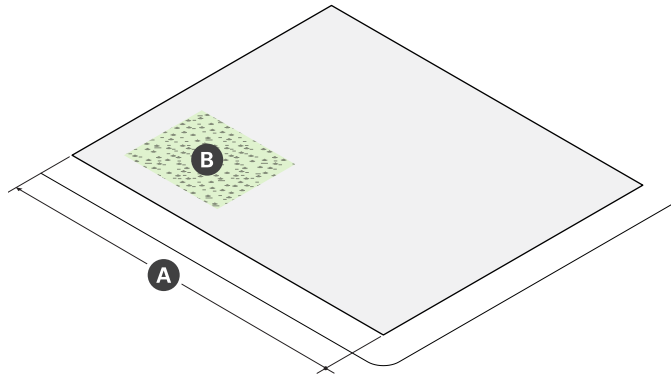

| Lot Dimensions       |       |
|----------------------|-------|
| <b>A</b> Width (min) | 30 ft |

| Lot Coverage                |      |
|-----------------------------|------|
| <b>B</b> Lot Coverage (max) | 100% |
| <b>C</b> Green Factor (min) | 0.20 |

### b. Building Placement

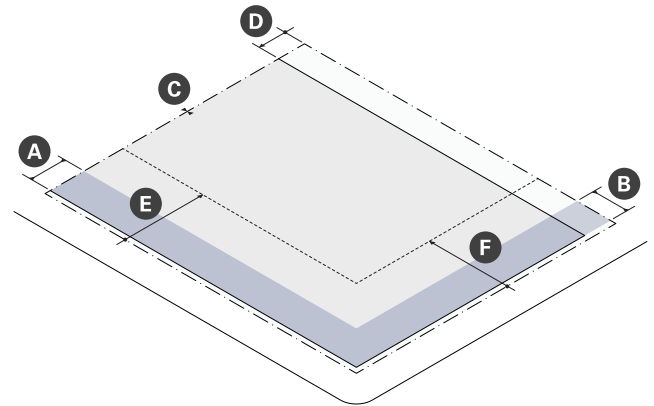

| Building Setbacks                        |       |       |
|--|-------|-------|
| <b>A</b> Primary Front Setback (min/max) | 2 ft  | 15 ft |
| <b>B</b> Secondary Front Setback         | 2 ft  | 15 ft |
| <b>C</b> Side Setback (min)              | 0 ft  |       |
| Side Setback Abutting NR or LHD (min)    | 5 ft  |       |
| <b>D</b> Rear Setback (min)              | 10 ft |       |
| Rear Setback Abutting NR (min)           | 15 ft |       |

| Parking Setbacks                       |       |
|--|-------|
| <b>E</b> Primary Front Setback (min)   | 30 ft |
| <b>F</b> Secondary Front Setback (min) | 30 ft |

## 8. Lab Building (continued)

### c. Height & Massing

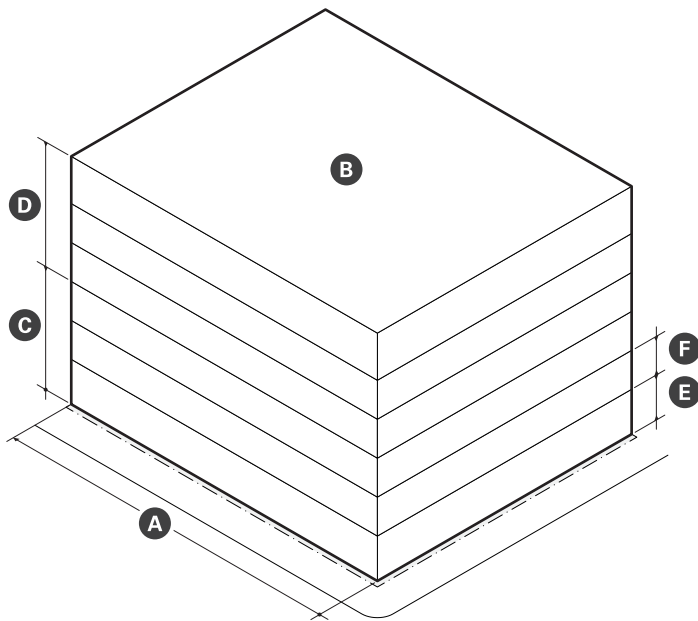

| Main Body                          |                                    |
|------------------------------------|------------------------------------|
| <b>A</b> Width (max)               | 240 ft                             |
| Facade Build Out (min)             | --                                 |
| Primary Frontage                   | 80%                                |
| Secondary Frontage                 | 65%                                |
| <b>B</b> Floor Plate               | 35,000 sf                          |
| Building Height, Stories (min)     | --                                 |
| <b>C</b> Primary Frontage          | 4 stories                          |
| <b>D</b> Secondary Frontage        | 3 stories                          |
| <b>E</b> Building Height (max)     | Varies by<br>CC Map<br>Designation |
| <b>E</b> Ground Story Height (min) | 14 ft                              |
| <b>F</b> Upper Story Height (min)  | 10 ft                              |

### d. Uses & Features

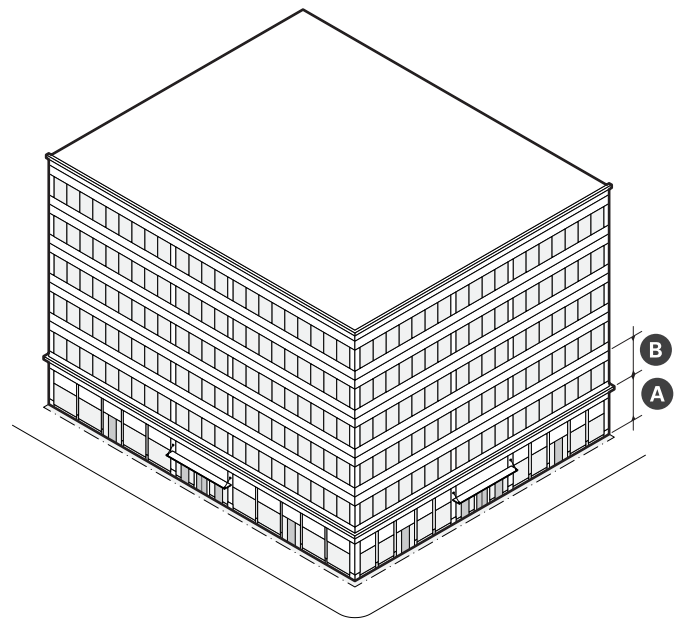

| Facade Composition                          |         |
|---|---------|
| <b>A</b> Ground Story Fenestration (min)    | 70%     |
| <b>B</b> Upper Story Fenestration (min/max) | 20% 70% |
| Blank Wall (max)                            | 20 ft   |

| Use & Occupancy              |       |
|------------------------------|-------|
| Entrance Spacing (max)       | 30 ft |
| Commercial Space Depth (min) | 30 ft |

## 6.0 COMMERCIAL DISTRICTS

Commercial Core (CC)

e. Reserved

## 9. Building Components

- a. Building components are accessory features that increase the habitable square footage or enhance the usefulness of a building.
- b. The following building frontage types are permitted in the Commercial Core (CC) district:
  - i. Awning (See §X)
  - ii. Entry Canopy (See §X)
  - iii. Bay (See §X)
  - iv. Roof Deck (See §X)
- c. Building components not expressly authorized are prohibited.

## D. Awning

- i. A wall mounted, pitched covering extending from a building to provide shade and weather protection for pedestrians.

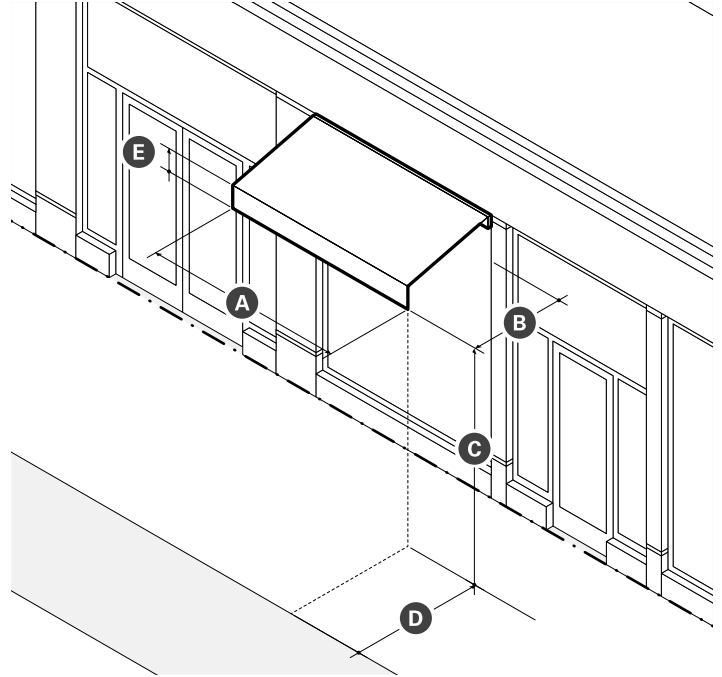

| Dimensions                       |            |
|----------------------------------|------------|
| <b>A</b> Width (min)             | See §X     |
| <b>B</b> Projection (min)        | 3 ft       |
| <b>C</b> Clearance (min)         | 8 ft clear |
| <b>D</b> Setback from Curb (min) | 1.5 ft     |
| <b>E</b> Valance Height (max)    | 12 in      |

- ii. Standards
  - a). Awnings must be securely attached to and supported by the building and must fit the windows or doors the awning is attached to.
  - b). An awning must be made of durable, weather-resistant material that is water repellent.
  - c). Internally illuminated or back-lit awnings are prohibited.
  - d). An awning that projects over the sidewalk of a public thoroughfare requires compliance with all City Ordinances.

# 6.0 COMMERCIAL DISTRICTS

Commercial Core (CC)

## E. Entry Canopy

- i. An entry canopy is a wall-mounted structure that provides shade and weather protection over the entrance of a building.

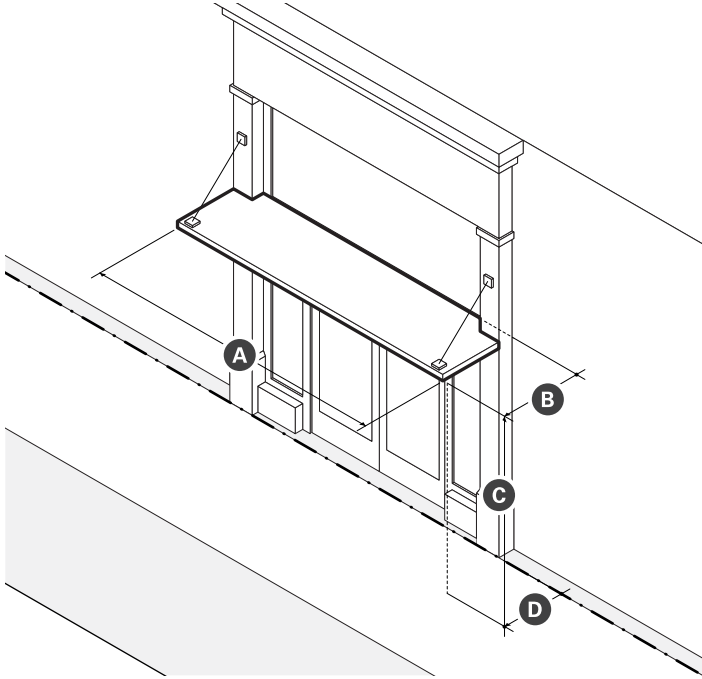

| Dimensions                           |            |
|--------------------------------------|------------|
| <b>A</b> Width (min)                 | See §X     |
| <b>B</b> Depth (max)                 | 3 ft       |
| <b>C</b> Clearance (min)             | 8 ft clear |
| Permitted Setback Encroachment (max) | 100%       |

- ii. Standards
  - a). Entry canopies must be visually supported by brackets, cables, or rods.
  - b). The width of an entry canopy must be equal to or greater than the width of the doorway surround or exterior casing it is mounted over.

## F. Bay

- i. A bay is a window assembly extending from the main body of a building to permit increased light, provide multi-direction views, and articulate a building's facade.

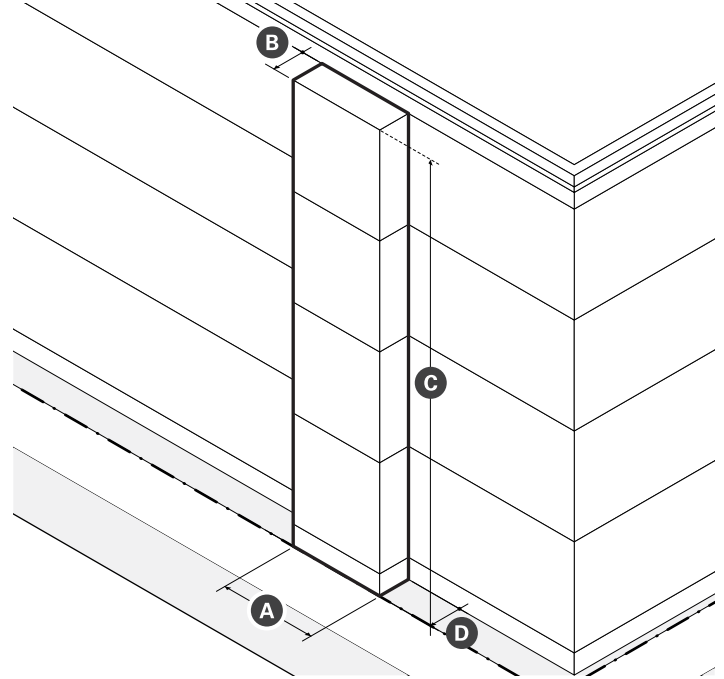

| Dimensions                                    |                            |
|---|----------------------------|
| <b>A</b> Width (min)                          | 50% of facade or elevation |
| <b>B</b> Depth (max)                          | 3 ft                       |
| <b>C</b> Height (max)                         | Height of Building         |
| Fenestration (min)                            | 60%                        |
| <b>D</b> Permitted Setback Encroachment (max) | 3 ft                       |

- ii. Standards
  - a). Bays must have a foundation extending all the way to ground level or be visually supported by brackets or other architectural supports.
  - b). Bays projecting over the sidewalk of a public thoroughfare must have two (2) stories of clearance and compliance with all City Ordinances.
  - c).



## G. Roof Deck

- i. A roof deck is a roofless, raised platform on the roof of a building that provides outdoor amenity space.

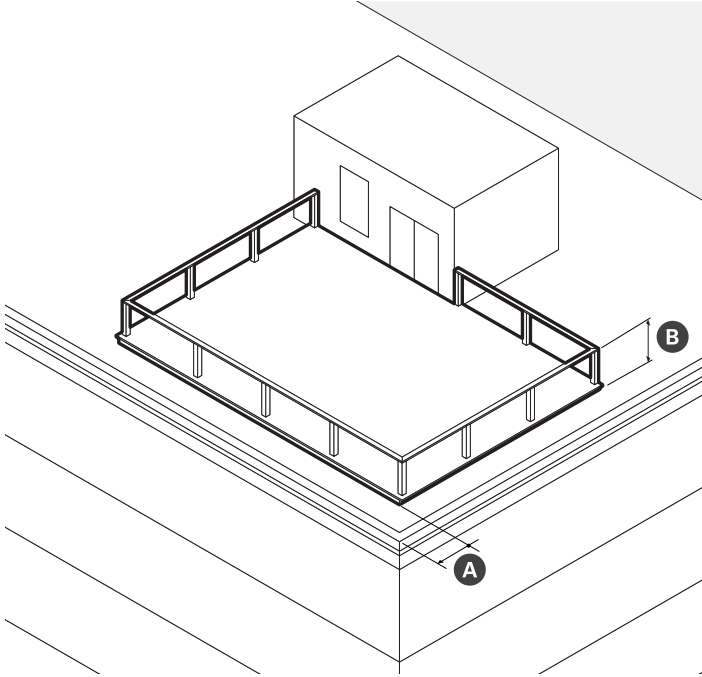

| Dimensions                         |      |
|------------------------------------|------|
| <b>A</b> Setback from Facade (min) | 5 ft |
| <b>B</b> Railing Height (min)      | 4 ft |

- ii. Standards
  - a). Roof decks are only permitted on flat roofs.
  - b). The flooring of a roof deck must be no more than two feet above the roof supporting the deck.
  - c). Roof decks located within five (5) feet of a side rear lot line abutting the NR district must provide sight obscuring visual screening so that it is at least fifty percent (50%) opaque.
  - d). Roof deck access structures, such as stairwell penthouses, may not exceed 10 ft. in height and may only serve to enclose the access stairs.

## 10. Private Frontage

- a. Private frontage must be designed as a building frontage type.
- b. Building frontage types facilitate access to principal entrances and serve as the interface and transition between the private realm (building interiors) and the public realm (sidewalks and civic spaces).
- c. The following building frontage types are permitted in the Commercial Core (CC) district:
  - i. Forecourt (See §X)
  - ii. Lobby Entrance (See §X)
  - iii. Storefront (See §X)
  - iv. Terrace (See §X)
  - v. Arcade (See §X)
- d. Building frontage types may be combined as indicated for each type and multiple frontage types may exist for buildings that have more than one principal entrance.

# 6.0 COMMERCIAL DISTRICTS

Commercial Core (CC)

## E. Forecourt

- i. A forecourt is a frontage type featuring a landscaped semi-public area, open to the sky, formed by a recess in a central portion of a buildings facade.

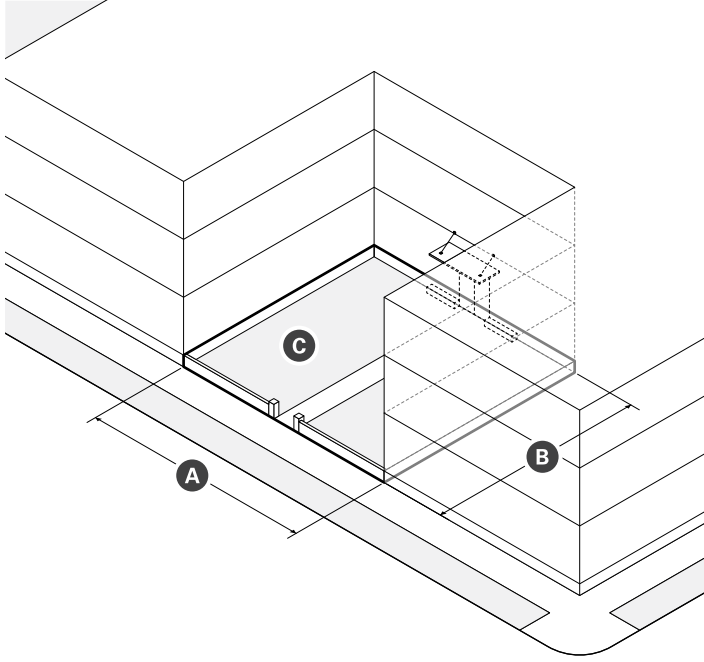

| Dimensions                     |        |
|--------------------------------|--------|
| <b>A</b> Width (min)           | 12 ft  |
| <b>B</b> Depth (min)           | 12 ft  |
| Height to Width Ratio (max)    | 2 to 1 |
| <b>C</b> Landscaped Area (min) | 30%    |

- ii. Standards
  - a). Paving, excluding driveways, must match the abutting sidewalk unless paved with permeable paving.
  - b). Forecourts are considered part of the building for the purpose of measuring facade build out.
  - c). A forecourt must be enclosed by walls on three sides.
  - d). Porches, stoops, porticos, entry canopies, and balconies may encroach into the forecourt.
  - e). Driveways, parking spaces, passenger drop-offs, garage entrances, loading and service areas, exhaust vents, mechanical equipment, and refuse or recycling storage are not permitted in forecourts.

## F. Lobby Entrance

- i. A lobby entrance is a frontage type featuring a non-load bearing assembly of entry doors and windows providing access and light to the lobby of a building.

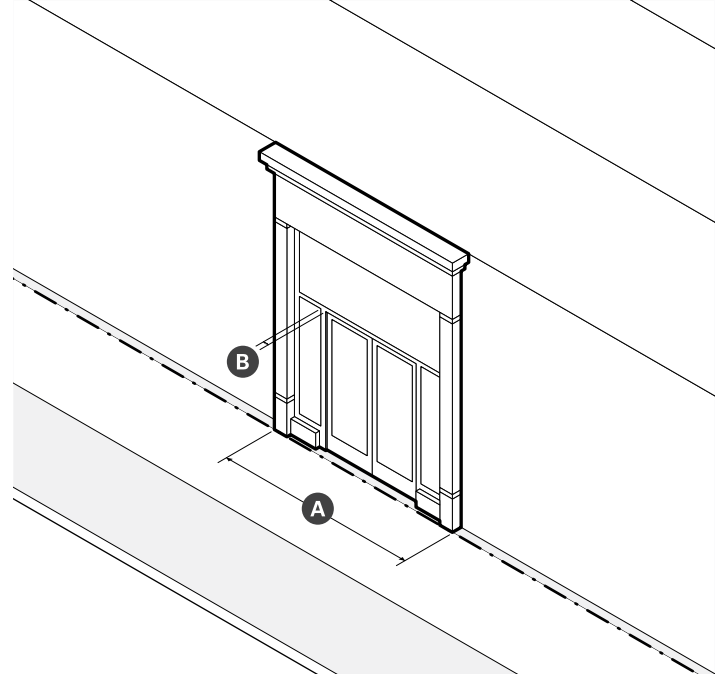

| Dimensions                                   |       |
|--|-------|
| <b>A</b> Width (max)                         | 20 ft |
| <b>B</b> Distance between Fenestration (max) | 2 ft  |
| Depth of Recessed Entry (max)                | 5 ft  |

- ii. Standards
  - a). Lobby entrances must be well-defined, clearly visible, and universally accessible from the abutting sidewalk.
  - b). When a lobby entrance is setback from the front lot line, the frontage must be paved to match the abutting sidewalk.
  - c). Lobby entrances should be made clearly identifiable using a difference in design from the rest of the facade.
  - d). Lobby entrances should include weather protection.

## G. Storefront

- i. A storefront is a frontage type featuring a non-load bearing assembly of commercial entry doors and substantial windows for the display of goods, services, and signs.

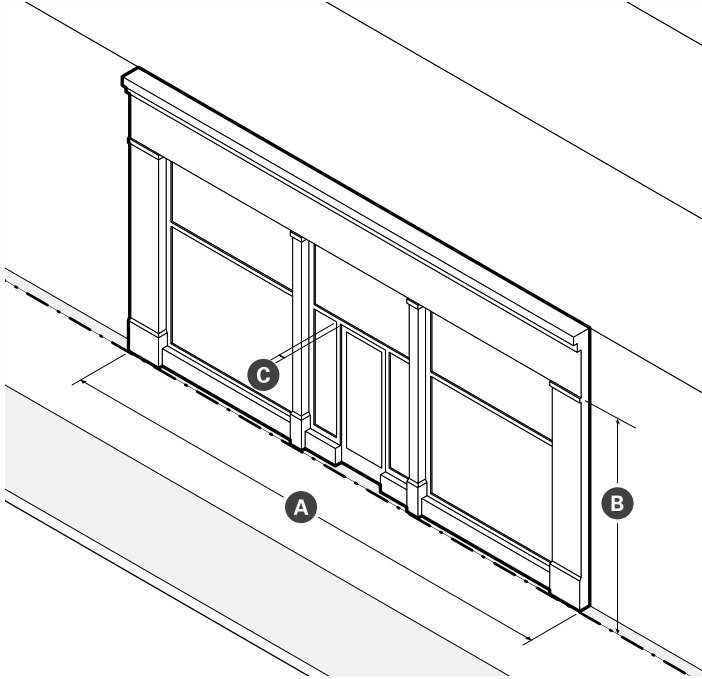

| Dimensions                          |       |
|-------------------------------------|-------|
| Width (max)                         | 30 ft |
| Distance between Fenestration (max) | 2 ft  |
| Depth of Recessed Entry (max)       | 5 ft  |

- ii. Standards
  - a). When storefronts are setback from the front lot line, the frontage must be paved to match the abutting sidewalk.
  - b). Open-ended, operable awnings are encouraged for weather protection.
  - c). Bi-fold glass windows and doors and other storefront systems that open to permit a flow of customers between interior and exterior space are encouraged.

## H. Terrace

- i. A terrace is a frontage type featuring an elevation of the ground level to accommodate a change in grade that provides circulation and access along the front of a building.

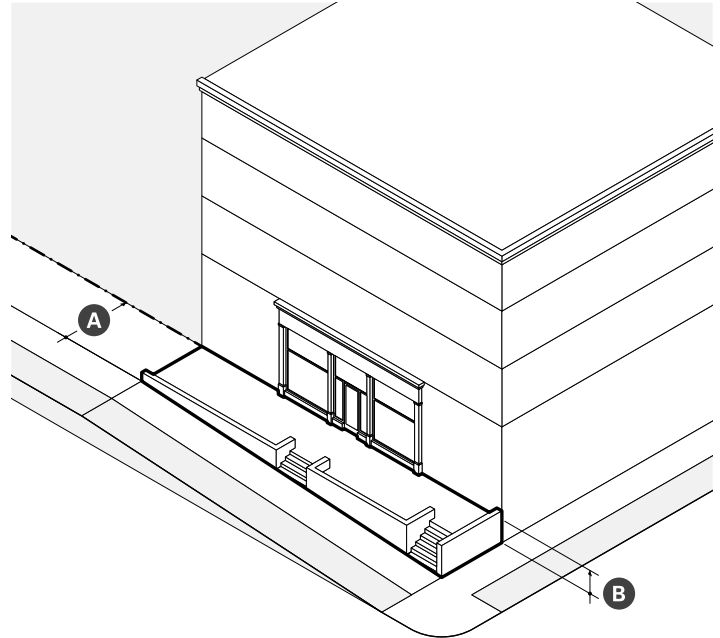

| Dimensions                      |              |
|---------------------------------|--------------|
| Depth (min)                     | 20 ft        |
| Finish above Sidewalk (min/max) | 18 in   4 ft |
| Distance between Stairs (max)   | 50 ft        |

- ii. Standards
  - a). Terrace frontage must be paved to match the abutting sidewalk.
  - b). Frequent steps up to the terrace are required to avoid blank wall along the sidewalk and maximize pedestrian access.

# 6.0 COMMERCIAL DISTRICTS

Commercial Core (CC)

## I. Arcade

- i. An arcade is a frontage type featuring a pedestrian walkway covered by the upper floors of a building. The ground story facade is setback and upper floors are supported by a colonnade or supports.

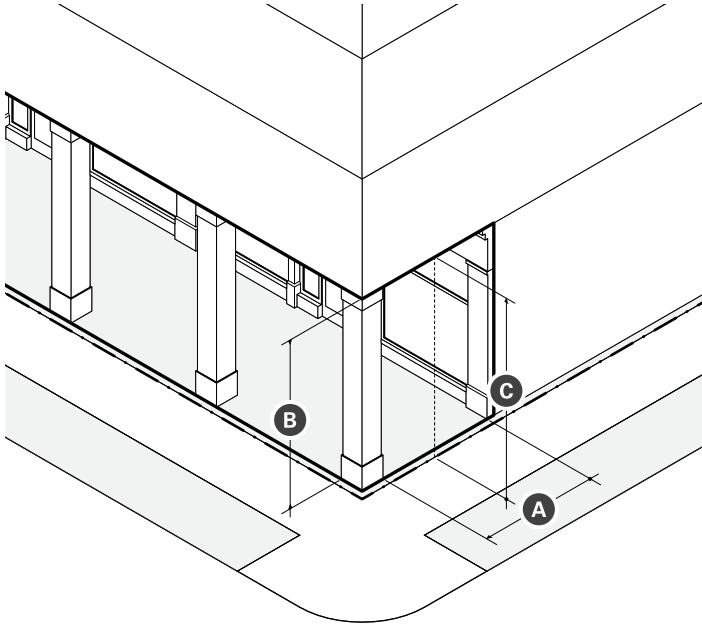

| Dimensions                   |         |       |
|------------------------------|---------|-------|
| <b>A</b> Depth (min/max)     | 10 ft   | 15 ft |
| <b>B</b> Height (max)        | 1 story |       |
| <b>C</b> Clearance (min/max) | 14 ft   | 24 ft |

- ii. Standards
  - a). Arcades must extend the entire width of a building and must have a consistent depth.
  - b). Support columns or piers may be spaced no farther apart than they are tall.
  - c). Arcades are considered part of the building for the purpose of measuring facade build out.
  - d). Arcades may be combined only with storefront and lobby entrance frontages
  - e). The finished ceiling of an arcade interior may be arched or flat, but must have a greater clearance than the openings between columns or piers.

## 11. Building Design Standards

- a. Pedestrian Circulation
  - i. When development occurs on any lot abutting a thoroughfare where the sidewalk is less than twelve (12) feet in total width, the building must be setback an additional distance to accommodate expansion of the abutting sidewalk to a width of at least twelve (12) feet. The minimum and maximum front setbacks for each building type are increased accordingly.
- b. Facade Design
  - i. All building facades must provide surface relief through the use of balconies, Bays, cladding, columns, corner boards, cornices, door surrounds, moldings, piers, pilasters, sills, sign bands, windows, and other architectural features that either recess or project from the average plane of the facade by at least four (4) inches.
  - ii. Vents, exhausts, and other utility features on building facades must be architecturally integrated into the design of the building.
  - iii. Building facades, excluding apartment buildings, must provide a frame for each storefront and lobby entrance in accordance with the following architectural techniques:
    - a). A horizontal lintel or beam (architrave) and cornice that extends across the full width of the building and is supported by columns, pilasters, or piers; or
    - b). A horizontal beam or fascia (architrave) positioned between columns, pilasters, or piers that extend from the upper stories of a building all the way to the ground.
  - iv. When present, a horizontal lintel, beam, or fascia (architrave) serves as the sign band for each storefront.
- c. Towers
  - i. The separation distance between all towers must be at least eighty (80) feet, measured from the exterior walls and excluding balconies.
  - ii. The separation distance between towers may be decreased to a minimum of fifty (50) feet by Special Permit through the use of creative architectural solutions such as offset towers/

**FIGURE 6.2 (a) Elements of a Storefront**

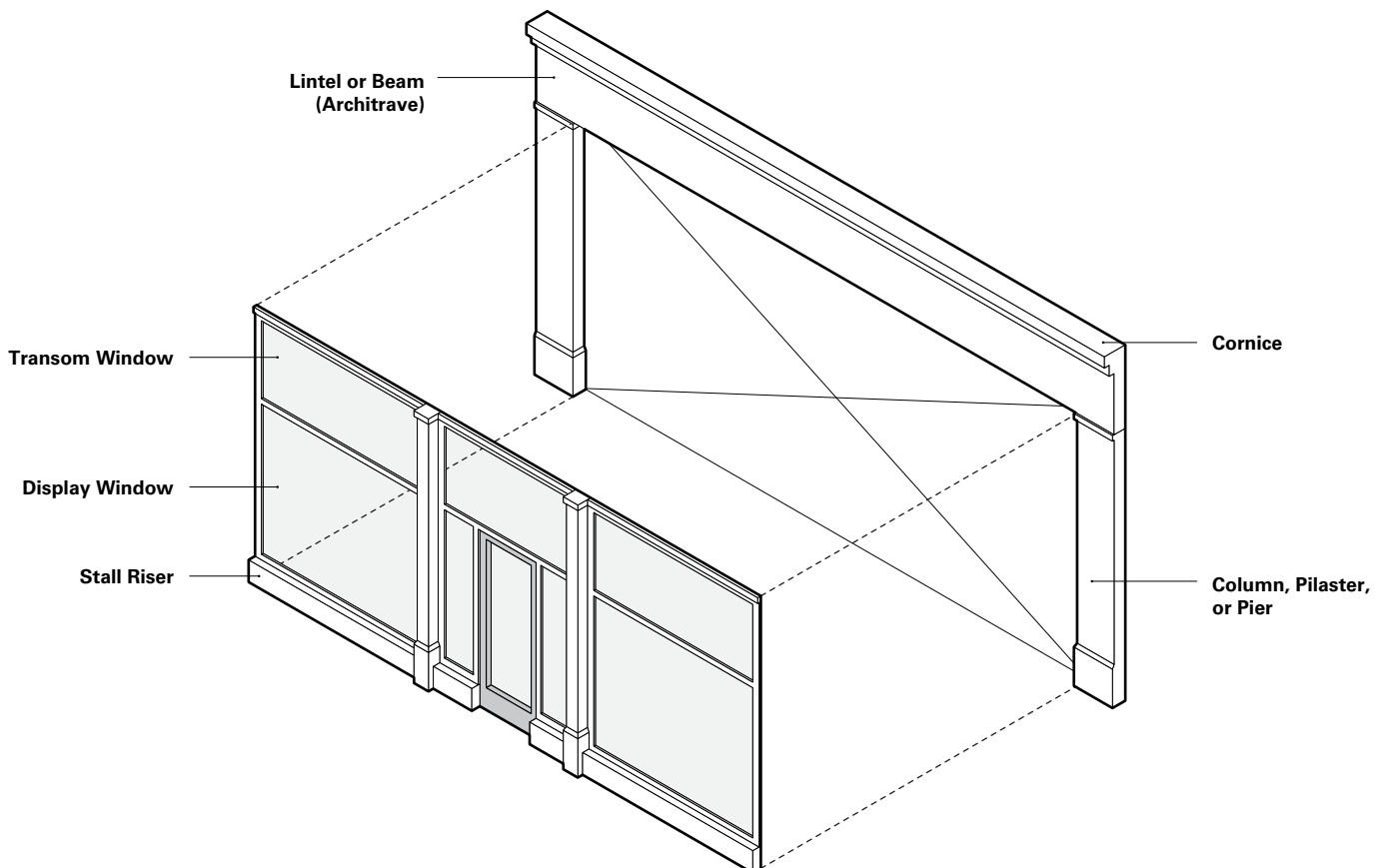

## 6.0 COMMERCIAL DISTRICTS

### Commercial Core (CC)

views, non-parallel walls, or tapering/curved tower forms, that increase the actual or perceived tower separation distance, provided that both privacy and natural light are provided and no adverse environmental conditions are created.

- iii. In its discretion to approve or deny a Special Permit authorizing a decrease in tower separation below the standard eighty (80) foot minimum, the Review Board shall consider the following:
  - a). The review considerations for all Special Permits (see Section 5.1 Special Permits);
  - b). View corridors from windows of new and existing towers;
  - c). The effectiveness of architectural techniques to increase the actual or perceived tower separation distance.

### 12. Architectural Design Guidelines

a. In the absence of any official architectural design guidelines adopted by the Planning Board, the following shall inform the Design Review process for all development within the High-Rise district.

- i. Facade Articulation
  - a). Building facades should be vertically articulated with Architectural Bays to visually break down and minimize the apparent mass of buildings, shorten the perception of distance/length, provide structure to the composition and disposition of fenestration, enhance pedestrian orientation, and add visual interest to the public realm.
  - b). Architectural bays should be derived, in general, from the building's structural bay spacing.
  - c). Architectural bays should have buttresses, pilasters, columns, or piers that extend either all the way to the ground or to the cornice and sideband of ground level storefronts.
  - d). Architectural bays should align, in general, with individual or groups of storefront and lobby entrance frontages of the ground story of a building.
  - e). In most circumstances, the vertical buttresses, pilasters, columns, or piers of Architectural Bays should always project further and be uninterrupted by any horizontal elements of a facade, excluding the cornice, band, or other architectural feature(s) used to differentiate ground level storefronts from upper stories.
- ii. Fenestration
  - a). Fenestration should align vertically within each architectural bay and horizontally across each story of a building.
  - b). Upper stories should have a window to wall

area proportion that is lower than that of the ground floor.

- c). Windows should be punched into walls and glass should be inset from exterior wall surfaces.
  - d). Series of windows set side by side to form a continuous horizontal band across a facade (aka 'ribbon windows') should be avoided.
  - e). Solid wall materials should be used to frame groups of windows to reduce the perceived scale of a building.
- iii. Materials
    - a). The palette of wall materials and colors used for a building should be kept to a minimum, preferably three. Similar wall materials as found on adjacent or nearby buildings should be used to strengthen district character and provide continuity and unity between buildings of divergent size, scale, and architectural styles.
    - b). Acceptable wall materials include architectural concrete or pre-cast concrete panels, natural or cast stone, curtain wall and heavy gage metal panel, and brick. Value added materials such as natural or cast stone, concrete, glazed or unglazed architectural terracotta, and brick should be used as wall materials where pedestrians closely encounter and interact with buildings.
    - c). Exterior Insulation and Finish Systems (EIFS) should never be used for the base of a building.
    - d). Horizontal or vertical board siding and shingles, whether wood, metal, plastic (vinyl), masonry, or composite materials, should be used only for smaller scale apartment buildings.
    - e). Two or more wall materials should be combined only one above the other. Wall materials appearing heavier in weight should be used below wall materials appearing lighter in weight.
    - f). Building wall materials that are lighter in color, tint, or shade should be used for the lower floors of a building, with materials darker in color, tint, or shade used above.
    - g). If a building's massing and pattern of fenestration is complex, simple or flat wall materials should be used; if a building's massing and pattern of fenestration is simple, walls should include additional texture and surface relief.
    - h). Side and rear building elevations that are visible from the public realm should have a level of trim and finish that is compatible with the facade of the building.

## 6.0 COMMERCIAL DISTRICTS

Commercial Core (CC)

- i). Balconies should have either metal railing or glass guardrail systems.
- iv. Storefronts
  - a). The design of storefronts should invite interaction, enliven the pedestrian environment, and provide a secondary, more intimate source of lighting at night.
  - b). Monotonous and repetitive storefront sign types, and sign designs should be avoided.
  - c). Where a pedestrian street intersects with a side street, commercial spaces should wrap the corner and include at least one storefront on the side street.
  - d). A paneled or rendered stallriser at least one (1) foot in height should be included below display windows.
  - e). Where height permits, transom windows should be included above storefront doors and display windows to allow additional natural daylight to penetrate into the interior space.
  - f). Awnings are encouraged for each storefront to provide weather protection for pedestrians and reduce glare for storefront display areas. Awnings should be open-ended, and operable.
  - g). Bi-fold glass windows and doors and other storefront systems that open to permit a flow of customers between interior and exterior space are encouraged.
- v. Entrances
  - a). Principal entrances should be optimally located, well defined, clearly visible, and universally accessible from the adjacent sidewalk.
  - b). Each ground floor use should have an individual entrance with direct access onto a sidewalk.
  - c). Storefront doors should not obstruct pedestrians walking past or alongside a building.
  - d). Lobby entrances required for upper story uses should be limited in width (frontage) and separate from the entrance for any ground floor uses.
  - e). Features such as a double-height ceiling, distinctive doorway, decorative lighting, recessed facade, or a change in paving material within the setback area should be used to make lobbies for upper story commercial uses distinctive while preserving floor space for other ground floor uses.
- vi. Details
  - a). Architectural details, ornamentation, and articulations should be used with building fenestration to create a harmonious composition that is consistent throughout the building, so that the building appears as a unified whole and not as a collection of unrelated parts that adds to the impression of bulk.
  - b). Exterior lighting (building, storefront, and landscape) should be integrated into the design of the building, create a sense of safety, and encourage pedestrian activity at night through layers of light that contribute to the nighttime experience.
  - c). Exterior lighting should relate to pedestrians and accentuate major architectural or landscape features, but should be shielded to reduce glare and eliminate light being cast into the night sky.
  - d). The upper portions of buildings, especially high-rise buildings, should provide visual interest and a variety in detail and texture to the skyline.
  - e). Mechanical and utility equipment should be integrated into the architectural design of the building or screened from public view. Penthouses should be integrated with the buildings architecture, and not appear as foreign structures unrelated to the building they serve.
  - f). Ventilation intakes/exhausts should be located to minimize adverse effects on pedestrian comfort along the sidewalk and within outdoor spaces.
  - g). Buildings at terminated vistas should be articulated with design features that function as focal points to create memorable views that add to the character and enhance the aesthetics of the neighborhood.



# 6.0 COMMERCIAL DISTRICTS

Commercial Core (CC)

# 6.0 COMMERCIAL DISTRICTS

Commercial Core (CC)

## 13. Use Provisions

- a. Permitted Uses
  - i. The use of real property is subject to the provisions of Article 9: Use Provisions of this Ordinance. Where the provisions of this section conflict with those of Article 9, the provisions of Article 9 apply.
  - ii. Uses are permitted according to Table 6.2.1.
  - iii. All uses must comply with any use-specific standards applicable for each use in §9.2 Use Definitions & Limitations.
  - iv. Uses permitted by Special Permit require additional development review in accordance with §15.2.1 Special Permits.
  - v. Use categories not expressly authorized are prohibited.
- b. Required Uses
  - i. A minimum of five percent (5%) of the gross floor area of any Commercial Building or Lab Building must be provided as leasable floor area for uses from the Arts & Creative Enterprise use category.

**TABLE 6.2 (a) Permitted Uses**

| Use Category<br>Specific Use                                 | CC | Use Specific Standards |
|--|----|------------------------|
| <b>Arts &amp; Creative Enterprise</b>                        |    |                        |
| Artisan Production   | P  | §9.2.2.a               |
| Arts Exhibition  | P  | §9.2.2.b               |
| Arts Sales & Services  | P  | §9.2.2.c               |
| Co-working   | P  | §9.2.2.d               |
| Design Services  | P  | §9.2.2.e               |
| Shared Workspaces & Arts Education                           | P  | §9.2.2.f               |
| <b>Civic &amp; Institutional</b>                             |    |                        |
| Community Center   | P  | §9.2.4.a               |
| Hospital   | SP | §9.2.4.b               |
| Library  | P  | §9.2.4.c               |
| Minor Utility Facility                                       | SP | §9.2.4.d               |
| Museum   | P  | §9.2.4.f               |
| Private Non-Profit Club or Lodge                             | SP | §9.2.4.g               |
| Religious & Educational Uses Protected by M.G.L. 40A. Sec. 3 | P  | §9.2.4.h               |
| <b>Commercial Services</b>                                   |    |                        |
| Animal Services (as noted below)                             | -- | §9.2.5.a               |
| Pet Grooming   | P  | §9.2.5.a.ii            |
| Veterinarian   | SP | §9.2.5.a.iv            |
| Assembly & Entertainment                                     | SP | §9.2.5.b               |
| Banking & Financial Services (except as noted below)         | P  | §9.2.5.c               |
| Personal Credit  | SP | §9.2.5.c.i             |
| Broadcast and/or Recording Studio                            | P  | §9.2.5.d               |
| Building & Home Repair Services                              | SP | §9.2.5.e               |

P - Permitted      SP - Special Permit Required      N - Not Permitted

# 6.0 COMMERCIAL DISTRICTS

Commercial Core (CC)

**TABLE 6.2 (a) Permitted Uses (continued)**

| Use Category<br>Specific Use                    | CC | Use Specific Standards |
|---|----|------------------------|
| Business Support Services                       | P  | §9.2.5.f               |
| Caterer/Wholesale Food Production               | SP | §9.2.5.g               |
| Day Care Service (as noted below)               | -- | §9.2.5.h               |
| Adult Day Care Center                           | P  | §9.2.5.h.i             |
| Child Day Care Center                           | P  | §9.2.5.h.ii            |
| Maintenance & Repair of Consumer Goods          | P  | §9.2.5.j               |
| Personal Services (except as noted below)       | P  | §9.2.5.k               |
| Body-Art Establishment                          | SP | §9.2.5.k.i             |
| Gym or Health Club                              | P  | §9.2.5.k.ii            |
| Funeral Home                                    | SP | §9.2.5.k.iii           |
| Health Care Provider                            | SP | §9.2.5.k.iv            |
| Recreation Facility                             | SP | §9.2.5.l               |
| Vehicle Parking, Commercial (except as follows) | P  | §9.2.5.m               |
| Bike Share Parking                              | P  | §9.2.5.m.i             |
| Car Share Parking (3 or less spaces)            | P  | §9.2.5.m.ii            |
| Car Share Parking (4 or more spaces)            | P  | §9.2.5.m.ii            |
| Public Parking                                  | P  | §9.2.5.m.iii           |
| <b>Eating and Drinking</b>                      |    |                        |
| Bar/Restaurant/Tavern                           | P  | §9.2.6.a               |
| Bakery/Café/Coffee Shop                         | P  | §9.2.6.b               |
| Formula Eating & Drinking Establishment         | SP | §9.2.6.c               |
| <b>Lodging</b>                                  |    |                        |
| Bed & Breakfast                                 | SP | §9.2.7.a               |
| Hotel or Hostel                                 | SP | §9.2.7.b               |
| <b>Office</b>                                   |    |                        |
| General Office                                  | P  | §9.2.8.a               |
| Research and Development and/or Laboratory      | P  | §9.2.8.b               |
| <b>Retail Sales</b>                             |    |                        |
| Building/Home Supplies & Equipment              | SP | §9.2.10.a              |
| Consumer Goods (except as follows)              | P  | §9.2.10.b              |
| Alcohol Sales                                   | SP | §9.2.10.b.i            |
| Drug Paraphernalia Store                        | N  | §9.2.10.b.ii           |
| Firearms Sales                                  | N  | §9.2.10.b.iii          |
| Medical Marijuana                               | N  | §9.2.10.b.iv           |
| Pet Store                                       | SP | §9.2.10.b.v            |

P - Permitted      SP - Special Permit Required      N - Not Permitted

# 6.0 COMMERCIAL DISTRICTS

Commercial Core (CC)

**TABLE 6.2 (a) Permitted Uses (continued)**

| Use Category<br>Specific Use       | CC | Use Specific<br>Standards |
|------------------------------------|----|---------------------------|
| Formula Retail                     | SP | §9.2.10.c                 |
| Fresh Food Market or Grocery Store | P  | §9.2.10.d                 |
| Farm/Vendor Market                 | P  | §9.2.10.e                 |
| <b>Urban Agriculture</b>           |    |                           |
| Farming (as noted below)           | -- | §9.2.11.a                 |
| Commercial Farm                    | P  | §9.2.11.a.i               |
| Community Farm                     | P  | §9.2.11.a.ii              |
| Community Gardening                | P  | §9.2.11.b                 |
| <b>Accessory Uses</b>              |    |                           |
| Urban Agriculture (as noted below) | -- | §9.2.12.d                 |
| Commercial Farming                 | P  | §9.2.12.d.iii             |

P - Permitted      SP - Special Permit Required      N - Not Permitted

# 6.0 COMMERCIAL DISTRICTS

Commercial Core (CC)

## 14. Vehicular Parking

- a. General
  - i. Vehicular parking must be provided according to Table 6.2 (b) except as follows:
    - a). Non-residential uses with five thousand (5,000) square feet or less of gross leasable floor area are exempt from any minimum requirements of Table 6.2 (b).
    - b). Any change in use within a non-residential structure constructed before the effective date of this Ordinance, provided that the change is to a permitted use, is exempt from any minimum requirements of Table 6.2 (b).
  - ii. There are no parking requirements for accessory uses.
  - iii. Motor vehicle parking spaces may be shared between uses on the same lot and buildings on the same block in accordance with §12.3 Shared Parking.
- b. Type
  - i. Motor vehicle parking may be provided as above ground structured parking or underground structured parking.
- c. Unbundled Parking
  - i. Motor vehicle parking spaces must be rented or leased as an option rather than a requirement of the rental, lease, or purchase of a dwelling unit or non-residential floor space.
  - ii. Bicycle parking must be provided at no cost or fee to customers, visitors, employees, tenants, and residents.
- d. Parking Design
  - i. The design of all parking is subject to §12.1 Bicycle Parking and §12.2 Motor Vehicle Parking of this Ordinance.
- ii. Driveways, curb cuts, and vehicular entrances to parking lots, parking structures, loading docks, and service areas are not permitted along primary front lot lines abutting a pedestrian street, but may provide access from a side street or alley.
- iii. Driveways may be located within a required side and rear setback areas, but are not permitted between the facade of a building and any front lot line.
- iv. Driveways may be no more than twenty four (24) feet in width at the frontage.
- v. Driveways may provide access in whole or in part on or across an abutting lot(s), provided that an access easement exists between all property owners.
- vi. Unless otherwise specified, only one (1) curb cut is permitted per front lot line.
- vii. Curb cuts must be located to minimize conflict with pedestrians, bicyclists, and motor vehicles on the thoroughfare they provide access to and from.
- viii. Curb cuts may be no wider than the driveway or vehicular entrance they serve, excluding flares or returned curbs.
- ix. Driveway crossings traversing sidewalks with paved furnishing zones must be designed to maintain the grade and clear width of the walkway they cross and must include sloped flares on either side of the driveway apron.
- x. Driveway crossings traversing sidewalks with continuously planted furnishing zones must be designed to maintain the grade and clear width of the walkway they cross and must include returned curbs.

**TABLE 6.2 (b) Vehicular Parking**

\*See Transit Orientation Map for distance to a Transit Station

| Use Category<br>Specific Use          | BICYCLE             |                    | MOTOR VEHICLE                     |                                       |
|---------------------------------------|---------------------|--------------------|-----------------------------------|---------------------------------------|
|                                       | Short-Term<br>(min) | Long-Term<br>(min) | Within a<br>Transit Area<br>(max) | Outside of a<br>Transit Area<br>(min) |
| <b>Arts &amp; Creative Enterprise</b> |                     |                    |                                   |                                       |
| Artisan Production                    | 1 / 10,000 sf       | 1 / 3,000 sf       | 1 / 800 sf                        | 1 / 1,000 sf                          |
| Arts Exhibition                       | 1 / 10,000 sf       | 1 / 3,000 sf       | 1 / 800 sf                        | 1 / 650 sf                            |
| Arts Sales & Services                 | 1 / 10,000 sf       | 1 / 3,000 sf       | 1 / 200 sf                        | 1 / 1,000 sf                          |
| Design Services                       | 1 / 10,000 sf       | 1 / 3,000 sf       | 1 / 800 sf                        | 1 / 1,000 sf                          |
| Shared Workspaces & Arts Education    | 1 / 10,000 sf       | 1 / 3,000 sf       | 1 / 800 sf                        | 1 / 650 sf                            |

sf - Gross Leasable Square Footage

DU - Dwelling Unit

RU - Rooming Unit

# 6.0 COMMERCIAL DISTRICTS

Commercial Core (CC)

**TABLE 6.2 (b) Vehicular Parking (continued)**

\*See Transit Orientation Map for distance to a Transit Station

| Use Category<br>Specific Use                            | BICYCLE             |   | MOTOR VEHICLE                     |                                       |
|---|---------------------|---|-----------------------------------|---------------------------------------|
|   | Short-Term<br>(min) | Long-Term<br>(min)                      | Within a<br>Transit Area<br>(max) | Outside of a<br>Transit Area<br>(min) |
| <b>Civic &amp; Institutional</b>                        |                     |   |                                   |                                       |
| Community Center  | 1 / 10,000 sf       | 4 / 10,000 sf                           | 1 / 1,800 sf                      | 1 / 600 sf                            |
| Educational Facility                                    | 1.0 /<br>classroom  | 4.0 /<br>classroom                      | 1.5 /<br>classroom                | 3.0 /<br>classroom                    |
| Hospital  | 10 per<br>entrance  | 1 / 5,000 sf                            | 1 / 200 sf                        | 1 / 1,000 sf                          |
| Library   | 1 / 3,000 sf        | 1 / 5,000 sf                            | 1 / 800 sf                        | 1 / 500 sf                            |
| Minor Utility Facility                                  | n/a                 | n/a                                     | n/a                               | n/a                                   |
| Museum  | 1 / 2,000 sf        | 1 / 10,000 sf                           | 1 / 800 sf                        | 1 / 500 sf                            |
| Private Non-Profit Club or Lodge                        | 1 / 2,000 sf        | 1 / 10,000 sf                           | 1 / 200 sf                        | 1 / 1,000 sf                          |
| <b>Commercial Services</b>                              |                     |   |                                   |                                       |
| Animal Services (as noted below)                        | 1 / 2,500 sf        | 1 / 10,000 sf                           | –                                 | –                                     |
| Pet Grooming  | –                   | –                                       | 1 / 500 sf                        | 1 / 400 sf                            |
| Veterinarian  | 1 / 2,000 sf        | 1 / 5,000 sf                            | 1 / 500 sf                        | 1 / 500 sf                            |
| Assembly & Entertainment                                | 1 / 40 seats        | 1 / 10,000 sf                           | 1 / 6 seats                       | 1 / 6 seats                           |
| Banking & Financial Services<br>(except as noted below) | 1 / 2,000 sf        | 1 / 10,000 sf                           | 1 / 450 sf                        | 1 / 400 sf                            |
| Broadcast and/or Recording Studio                       | 1 / 2,500 sf        | 1 / 10,000 sf                           | 1 / 800 sf                        | 1 / 600 sf                            |
| Building & Home Repair Services                         | 1 / 2,500 sf        | 1 / 10,000 sf                           | 1 / 1,000 sf                      | 1 / 2,000 sf                          |
| Business Support Services                               | 1 / 2,500 sf        | 1 / 10,000 sf                           | 1 / 900 sf                        | 1 / 600 sf                            |
| Caterer/Wholesale Food Production                       | 1 / 2,500 sf        | 1 / 10,000 sf                           | 1 / 800 sf                        | 1 / 1,000 sf                          |
| Day Care Service  | 2                   | 1 / 10,000 sf                           | 1 / 900 sf                        | 1 / 600 sf                            |
| Maintenance & Repair of Consumer Goods                  | 1 / 2,500 sf        | 1 / 10,000 sf                           | 1 / 750 sf                        | 1 / 1,000 sf                          |
| Personal Services (except as noted below)               | 1 / 2,500 sf        | 1 / 10,000 sf                           | 1 / 750 sf                        | 1 / 1,000 sf                          |
| Gym or Health Club                                      |                     |   | 1 / 200 sf                        | 1 / 500 sf                            |
| Funeral Home  |                     |   |                                   |                                       |
| Health Care Provider                                    | 1 / 2,000 sf        | 1 / 10,000 sf                           | 1 / 500 sf                        | 1 / 300 sf                            |
| Recreation Facility                                     | 1 / 2,500 sf        | 1 / 10,000 sf                           |                                   |                                       |
| Vehicle Parking   | n/a                 | 10 or 1 / 10<br>motor vehicle<br>spaces | n/a                               | n/a                                   |

sf - Gross Leasable Square Footage

DU - Dwelling Unit

RU - Rooming Unit

# 6.0 COMMERCIAL DISTRICTS

Commercial Core (CC)

**TABLE 6.2 (b) Vehicular Parking (continued)**

\*See Transit Orientation Map for distance to a Transit Station

| Use Category<br>Specific Use               | BICYCLE             |                    | MOTOR VEHICLE                     |                                       |
|--|---------------------|--------------------|-----------------------------------|---------------------------------------|
|  | Short-Term<br>(min) | Long-Term<br>(min) | Within a<br>Transit Area<br>(max) | Outside of a<br>Transit Area<br>(min) |
| <b>Eating and Drinking</b>                 |                     |                    |                                   |                                       |
| Bar/Restaurant/Tavern                      | 1 / 1,000 sf        | 1 / 5,000 sf       | 1 / 300 sf                        | 1 / 500 sf                            |
| Bakery/Café/Coffee Shop                    | 1 / 1,000 sf        | 1 / 5,000 sf       | 1 / 300 sf                        | 1 / 500 sf                            |
| Formula Eating & Drinking Establishment    | 1 / 1,000 sf        | 1 / 5,000 sf       | 1 / 300 sf                        | 1 / 500 sf                            |
| <b>Lodging</b>                             |                     |                    |                                   |                                       |
| Bed & Breakfast                            | 1 / 20 rooms        | 1 / 10 rooms       | 1 / DU + 1 / 4<br>guest rooms     | 1 / DU + 1 / 4<br>guest rooms         |
| Hotel or Hostel                            | 1 / 20 rooms        | 1 / 10 rooms       | 1 / 2 guest<br>rooms              | 1 / 2 guest<br>rooms                  |
| Short Term Rental                          | 1 / 20 rooms        | 1 / 10 rooms       | n/a                               | n/a                                   |
| <b>Office</b>                              |                     |                    |                                   |                                       |
| Co-Working                                 | 1 / 20,000 sf       | 1 / 3,000 sf       | 1 / 1,200 sf                      | 1 / 800 sf                            |
| General Office                             | 1 / 20,000 sf       | 1 / 3,000 sf       | 1 / 900 sf                        | 1 / 650 sf                            |
| Research and Development and/or Laboratory | 1 / 20,000 sf       | 1 / 5,000 sf       | 1 / 1,000 sf                      | 1 / 1,000 sf                          |
| <b>Residential</b>                         |                     |                    |                                   |                                       |
| Household Living                           | 0.1 / DU            | 1.0 / DU           | 1.0 / DU                          | 1.0 / DU                              |
| Group Living<br>(except as follows)        | 0.05 / room         | 0.5 / room         | –                                 | –                                     |
| Community or Group Residence               |                     |                    |                                   |                                       |
| Dormitory, Fraternity or Sorority          | 0.1 / room          | 0.5 / room         | .05 / bed                         | 1.0 / 4 beds                          |
| Homeless Shelter                           |                     |                    | 4.0                               | 4.0                                   |
| Nursing Home/Assisted Living Facility      |                     |                    | 1 / 6 beds                        | 1 / 6 beds                            |
| Single Room Occupancy Housing              |                     |                    | 1 / 6 beds                        | 1 / 4 beds                            |
| <b>Retail Sales</b>                        |                     |                    |                                   |                                       |
| Building/Home Supplies & Equipment         | 1 / 2,500 sf        | 1 / 10,000 sf      | 1 / 1,000 sf                      | 1 / 1,000 sf                          |
| Consumer Goods (except as follows)         | 1 / 2,500 sf        | 1 / 10,000 sf      | 1 / 1,500 sf                      | 1 / 750 sf                            |
| Packaged Liquor                            |                     |                    |                                   |                                       |
| Medical Marijuana                          |                     |                    |                                   |                                       |
| Pet Store                                  |                     |                    |                                   |                                       |
| Formula Retail                             | 1 / 2,500 sf        | 1 / 10,000 sf      | 1 / 1,500 sf                      | 1 / 750 sf                            |
| Fresh Food Market or Grocery Store         | 1 / 1,000 sf        | 1 / 10,000 sf      | 1 / 500 sf                        | 1 / 1,500 sf                          |
| Farm/Vendor Market                         | n/a                 | n/a                | n/a                               | 1 / 1,500 sf                          |

sf - Gross Leasable Square Footage

DU - Dwelling Unit

RU - Rooming Unit

- xi. The appearance of any walkway (ie. scoring pattern or special paving) must be maintained across any driveway or alley to indicate that, although a vehicle may cross, the area traversed by a vehicle remains part of the sidewalk.
- e. Parking Location
  - i. Required motor vehicle parking, excluding any required handicapped parking, may be provided off-site according to the following:
    - a). The off-site parking must be located within one thousand three hundred and twenty (1,320) feet in walking distance to the lot it will serve, measured from the nearest point of the off-site parking along block faces and walkways to the principal entrance of the use served;
    - b). Pedestrian access to off-site motor vehicle parking must be via a paved sidewalk or walkway.
    - c). A lease, recorded covenant, or other comparable legal instrument guaranteeing long term use of the site must be provided to the review board or building official and executed and filed with the Registry of Deeds.
  - ii. For real property located in more than one municipality, motor vehicle parking need not be located within the City of Somerville.
- f. Parking Relief
  - i. Relief from the parking standards of Table 6.2 (b) requires a special permit.
    - a). In its discretion to approve or deny a special permit authorizing relief from the parking standards of Table 6.2 (b), the review board shall consider the following:
      - i). The supply and demand of on-street parking in the neighborhood, as determined through a parking study.
      - ii). Mobility management programs and services provided by the applicant to reduce the demand for parking.
      - iii). That parking provided in excess of any maximum permitted does not result in the increase in impervious lot area.
  - a). Each ground story non-residential use must identify the street address either on the principal entrance door or above or beside the principal entrance of the use.
  - b). All residential building types must identify the street address either on the principal entrance door, above or beside the principal entrance, or on a mailbox.
  - ii. Address signs must be made easily visible through the use of colors or materials that contrast with the background material they are attached to and must be conspicuously located to provide visibility from the thoroughfare that the building faces.
  - iii. Address signs must be twelve (12) inches in height or less and may include the name of the occupant.

### 15. Site Development

- a. General
  - i. Development is subject the provisions of Article 10: Site Development Standards of this Ordinance. Where the provisions of this section conflict with those of Article 10, the provisions of Article 10 apply.
- b. Signs
  - i. A sign, individual numerals or letters, or a nonelectrical nameplate identifying the property address is required for all real property as follows:



# 6.0 COMMERCIAL DISTRICTS

Commercial Core (CC)

## 6.3 COMMERCIAL INDUSTRY (CI)

### 1. Description

The Commercial Industry district is characterized by large floorplate buildings up to four (4) stories in height. Buildings are typically setback by parking and include warehouse and factory styles along with multi story offices. The district is entirely commercial, with uses that are typically auto-oriented, commercial service, industrial, or office in nature.

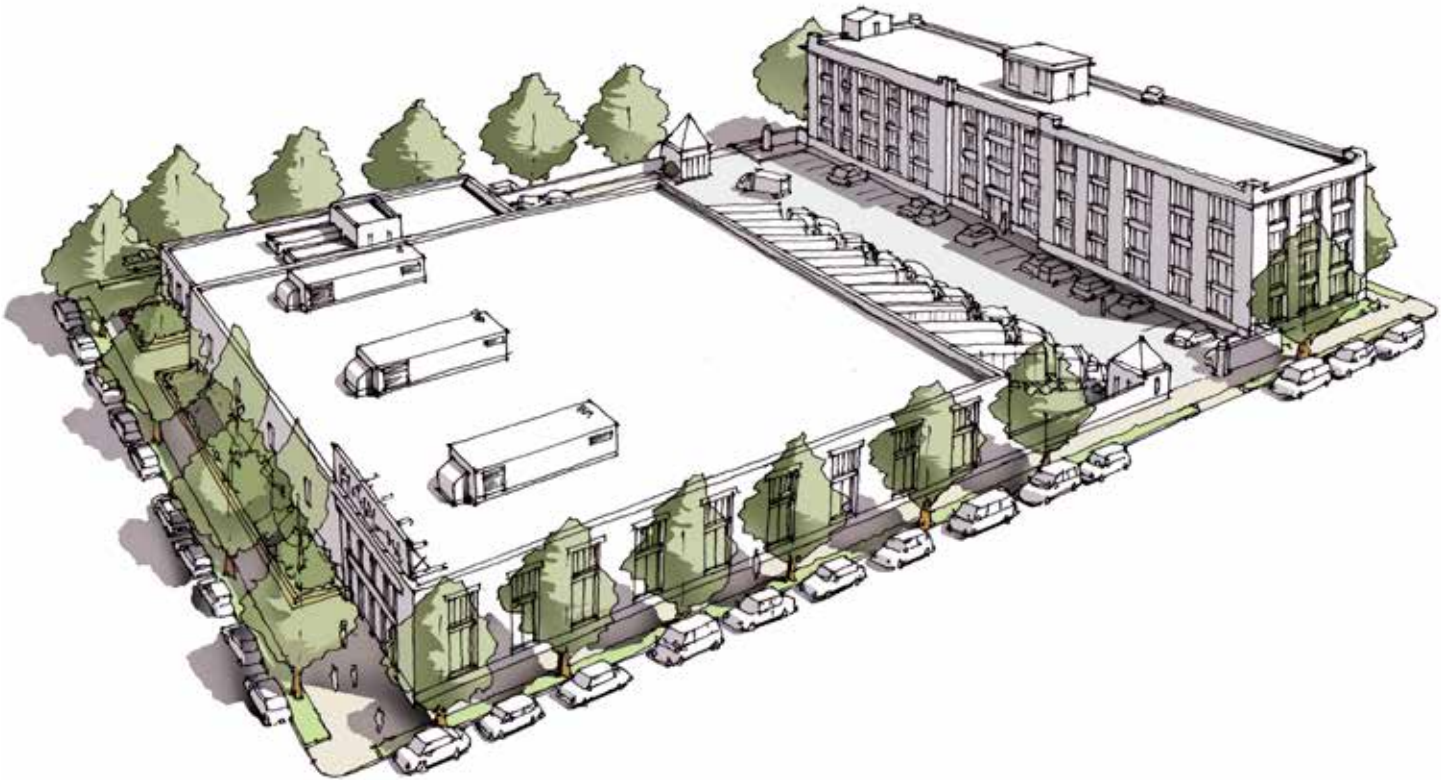

# 6.0 COMMERCIAL DISTRICTS

## Commercial Industry (CI)

### 2. Intent

- a. To maintain industrial and commercial activities that provide employment opportunities and business-to-business commerce.
- b. To maintain already existing areas appropriate for moderate- and large-scale, low-rise and mid-rise buildings and community- and region-serving commercial uses that do not readily assimilate into other zoning districts.

### 3. Purpose

- a. To permit the development of moderate-scale low- and mid-rise buildings.
- b. To provide quality commercial spaces and permit light & moderate industrial and large commercial uses.

### 4. Applicability

- a. The section is applicable to all real property within the Commercial Industry district as shown on the Official Zoning Map of the City of Somerville.

### 5. Development Review

- a. Development on any lot requires the submittal of a development review application to the Building Official and the issuance of a Zoning Compliance Certificate.
- b. Proposed development may or may not necessitate the need for Site Development Plan Approval, a Special Permit, or a Variance based on the nature of the proposal. In such cases, additional development review is required in accordance with Article 15: Administration.
  - i. The Zoning Board of Appeals is the decision making authority for all development in the Commercial Business district.
- c. Upon verification that no additional development review is necessary or completion of the required development review, a Zoning Compliance Certificate shall be issued by the Building Official to certify compliance with the provisions and procedures of this Ordinance.

### 6. Building Types

- a. One (1) principal building type may be built on each lot.
- b. The following building types are permitted by Site Development Plan Approval in the Commercial Core district:
  - i. Commercial Building
- c. Accessory structures are regulated according to Article 10: Development Standards of this Ordinance.

## 7. Commercial Building

A multi-story building type limited to commercial uses on all floors.

The following images are examples of the commercial building type and are intended only for illustrative purposes.



# 6.0 COMMERCIAL DISTRICTS

Commercial Industry (CI)

## 7. Commercial Building (continued)

### a. Lot Standards

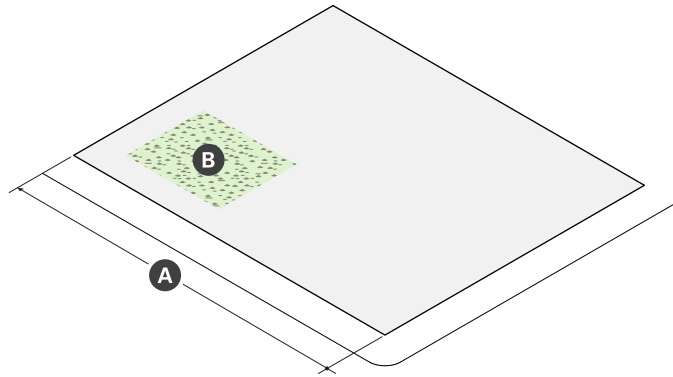

| Lot Dimensions       |       |
|----------------------|-------|
| <b>A</b> Width (min) | 30 ft |

| Lot Coverage                |      |
|-----------------------------|------|
| <b>B</b> Lot Coverage (max) | 100% |
| <b>C</b> Green Factor (min) | 0.20 |

### b. Building Placement

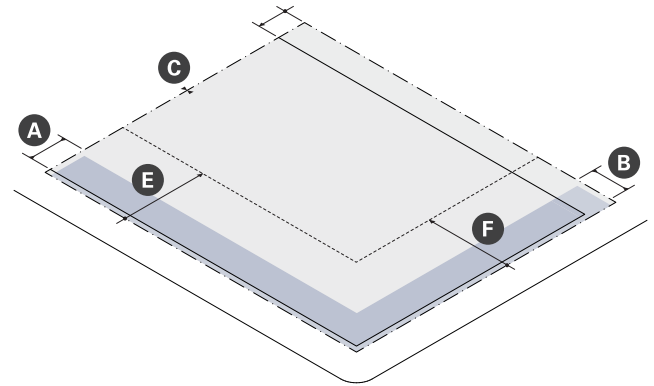

| Building Setbacks                        |       |       |
|--|-------|-------|
| <b>A</b> Primary Front Setback (min/max) | 2 ft  | 15 ft |
| <b>B</b> Secondary Front Setback         | 2 ft  | 15 ft |
| <b>C</b> Side Setback (min)              | 0 ft  |       |
| Side Setback Abutting NR or LHD (min)    | 5 ft  |       |
| <b>D</b> Rear Setback (min)              | 10 ft |       |
| Rear Setback Abutting NR (min)           | 15 ft |       |

| Parking Setbacks                       |       |
|--|-------|
| <b>E</b> Primary Front Setback (min)   | 30 ft |
| <b>F</b> Secondary Front Setback (min) | --    |
| Surface Parking                        | 30 ft |
| Structured Parking                     | 30 ft |

## 7. Commercial Building (continued)

### c. Height & Massing

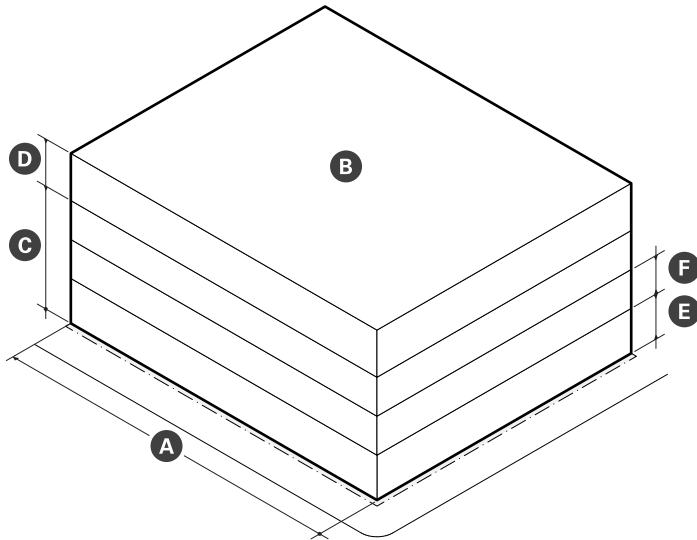

| Main Body                               |           |
|---|-----------|
| <b>A</b> Width (max)                    | 200 ft    |
| Facade Build Out (min)                  | --        |
| Primary Frontage                        | 80%       |
| Secondary Frontage                      | 65%       |
| <b>B</b> Floor Plate                    | 50,000 sf |
| <b>C</b> Building Height, Stories (max) | 4 stories |
| <b>D</b> Ground Story Height (min)      | 14 ft     |
| <b>E</b> Upper Story Height (min)       | 10 ft     |
| Building Height, Feet (max)             | 65 feet   |
| Roof Type                               | Flat      |

### d. Uses & Features

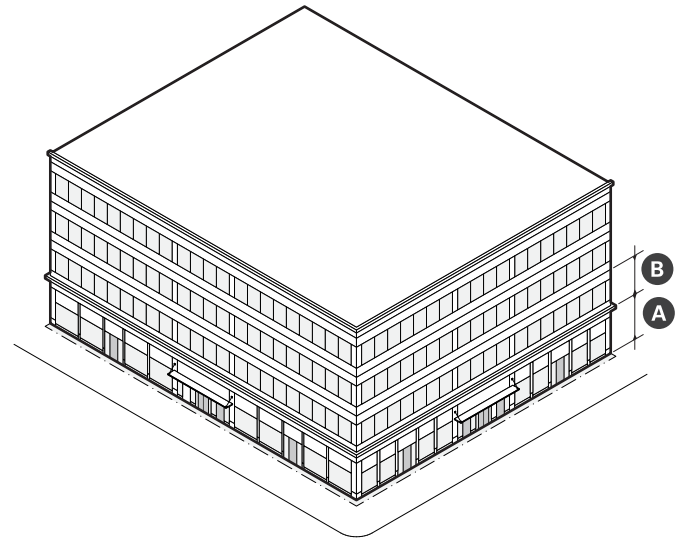

| Facade Composition                          |         |
|---|---------|
| <b>A</b> Ground Story Fenestration (min)    | 70%     |
| <b>B</b> Upper Story Fenestration (min/max) | 20% 70% |
| Blank Wall (max)                            | 20 ft   |

| Use & Occupancy              |       |
|------------------------------|-------|
| Entrance Spacing (max)       | 30 ft |
| Commercial Space Depth (min) | 30 ft |

## 6.0 COMMERCIAL DISTRICTS

Commercial Industry (CI)

e. Reserved



## 8. Building Components

- a. Building components are accessory features that increase the habitable square footage or enhance the usefulness of a building.
- b. The following building components are permitted in the Commercial Industry (CI) district:
  - i. Awning
  - ii. Entry Canopy
- c. Building components not expressly authorized are prohibited.

## D. Awning

- i. A wall mounted, pitched covering extending from a building to provide shade and weather protection for pedestrians.

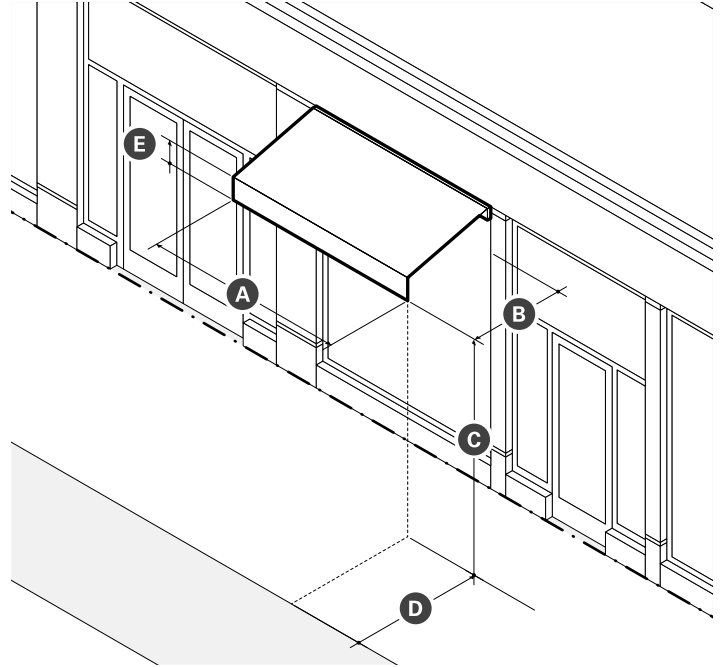

| Dimensions                       |            |
|----------------------------------|------------|
| <b>A</b> Width (min)             | See §X     |
| <b>B</b> Projection (min)        | 3 ft       |
| <b>C</b> Clearance (min)         | 8 ft clear |
| <b>D</b> Setback from Curb (min) | 1.5 ft     |
| <b>E</b> Valance Height (max)    | 12 in      |

- ii. Standards
  - a). Awnings must be securely attached to and supported by the building and must fit the windows or doors the awning is attached to.
  - b). An awning must be made of durable, weather-resistant material that is water repellent.
  - c). Internally illuminated or back-lit awnings are prohibited.
  - d). An awning that projects over the sidewalk of a public thoroughfare requires compliance with all City Ordinances.

# 6.0 COMMERCIAL DISTRICTS

Commercial Industry (CI)

## E. Entry Canopy

- i. An entry canopy is a wall-mounted structure that provides shade and weather protection over the entrance of a building.

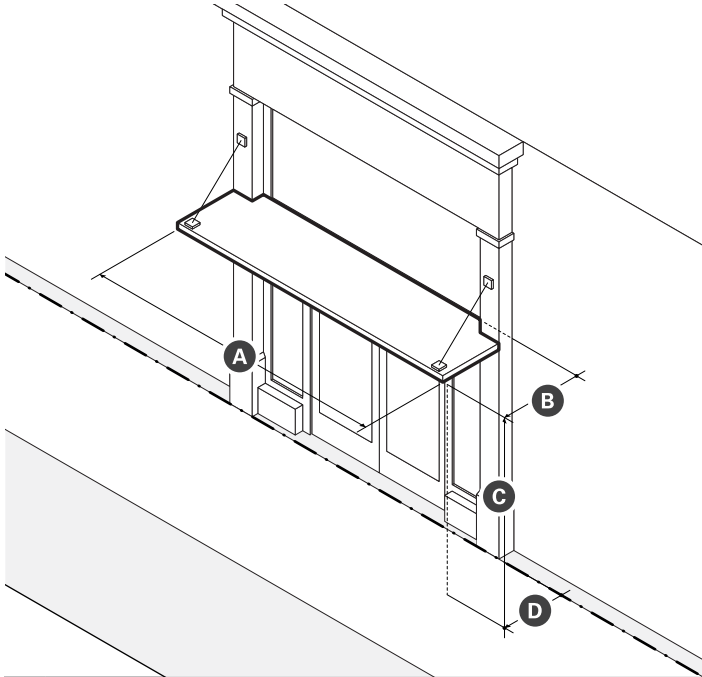

| Dimensions                                    |            |
|---|------------|
| <b>A</b> Width (min)                          | See §X     |
| <b>B</b> Depth (max)                          | 3 ft       |
| <b>C</b> Clearance (min)                      | 8 ft clear |
| <b>D</b> Permitted Setback Encroachment (max) | 100%       |

- ii. Standards
  - a). Entry canopies must be visually supported by brackets, cables, or rods.
  - b). The width of an entry canopy must be equal to or greater than the width of the doorway surround or exterior casing it is mounted over.

## 9. Private Frontage

- a. Private frontage must be designed as a building frontage type.
- b. Building frontage types facilitate access to principal entrances and serve as the interface and transition between the private realm (building interiors) and the public realm (sidewalks and civic spaces).
- c. The following building frontage types are permitted in the Commercial Industry (CI) district:
  - i. Forecourt
  - ii. Lobby Entrance
  - iii. Storefront
- d. Building frontage types may be combined as indicated for each type and multiple frontage types may exist for buildings that have more than one principal entrance.

## E. Forecourt

- i. A forecourt is a frontage type featuring a landscaped semi-public area, open to the sky, formed by a recess in a central portion of a building's facade.

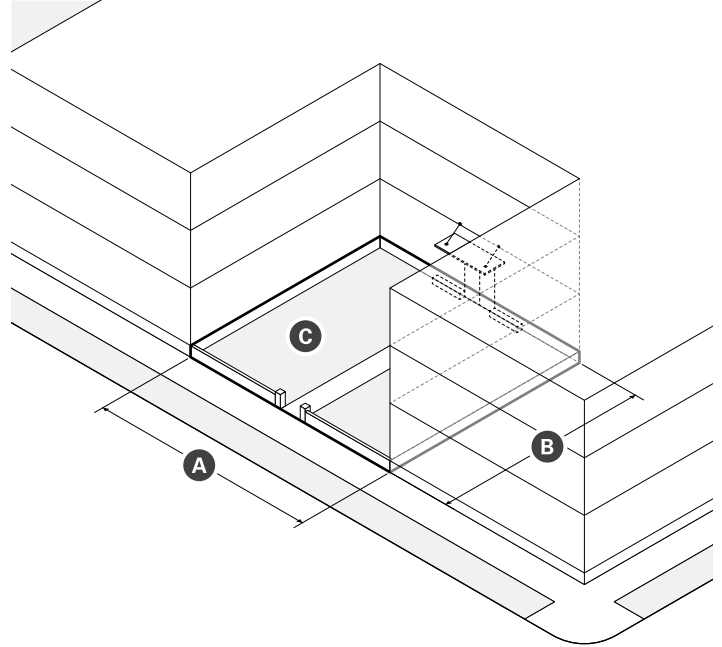

| Dimensions                           |        |
|--------------------------------------|--------|
| <b>A</b> Width (min)                 | 12 ft  |
| <b>B</b> Depth (min)                 | 12 ft  |
| <b>C</b> Height to Width Ratio (max) | 2 to 1 |
| Landscaped Area (min)                | 30%    |

- ii. Standards
  - a). Paving, excluding driveways, must match the abutting sidewalk unless paved with permeable paving.
  - b). Forecourts are considered part of the building for the purpose of measuring facade build out.
  - c). A forecourt must be enclosed by walls on three sides.
  - d). Porches, stoops, porticos, entry canopies, and balconies may encroach into the forecourt.
  - e). Driveways, parking spaces, passenger drop-offs, garage entrances, loading and service areas, exhaust vents, mechanical equipment, and refuse or recycling storage are not permitted in forecourts.
  - f). Forecourts may be combined with lobby entrance and storefront frontage types.

# 6.0 COMMERCIAL DISTRICTS

Commercial Industry (CI)

## F. Lobby Entrance

- i. A lobby entrance is a frontage type featuring a non-load bearing assembly of entry doors and windows providing access and light to the lobby of a building.

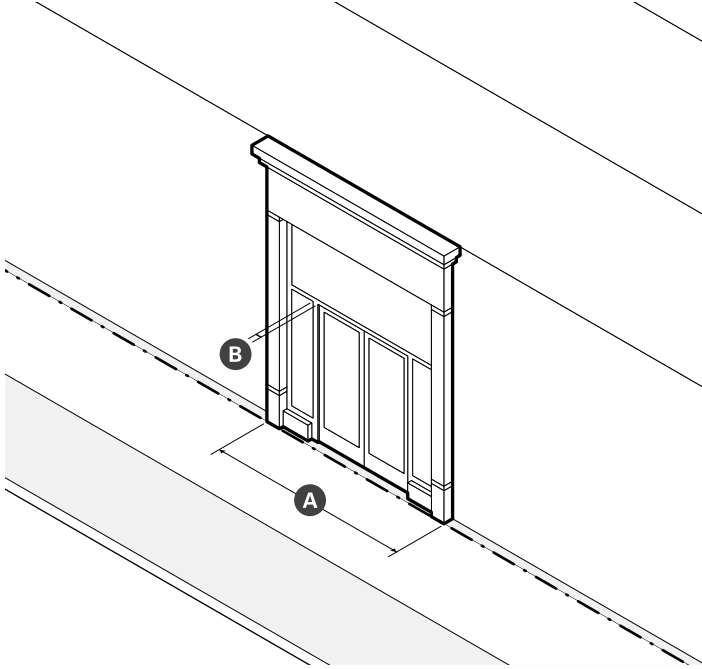

| Dimensions                                   |       |
|--|-------|
| <b>A</b> Width (max)                         | 20 ft |
| <b>B</b> Distance between Fenestration (max) | 2 ft  |
| Depth of Recessed Entry (max)                | 5 ft  |

- ii. Standards
  - a). Lobby entrances must be well-defined, clearly visible, and universally accessible from the abutting sidewalk.
  - b). When a lobby entrance is setback from the front lot line, the frontage must be paved to match the abutting sidewalk.
  - c). Lobby entrances should be made clearly identifiable using a difference in design from the rest of the facade.
  - d). Lobby entrances should include weather protection.

## G. Storefront

- i. A storefront is a frontage type featuring a non-load bearing assembly of commercial entry doors and substantial windows for the display of goods, services, and signs.

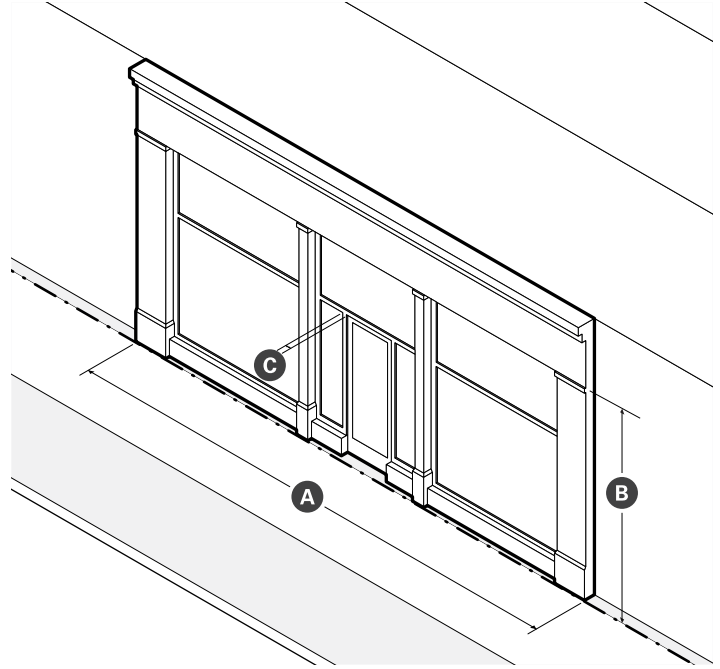

| Dimensions                                   |       |
|--|-------|
| <b>A</b> Width (max)                         | 30 ft |
| <b>B</b> Display Window Height (min)         | 8 ft  |
| <b>D</b> Distance between Fenestration (max) | 2 ft  |
| Depth of Recessed Entry (max)                | 5 ft  |

- ii. Standards
  - a). When storefronts are setback from the front lot line, the frontage must be paved to match the abutting sidewalk.
  - b). Open-ended, operable awnings are encouraged for weather protection.
  - c). Bi-fold glass windows and doors and other storefront systems that open to permit a flow of customers between interior and exterior space are encouraged.

## 10. Building Design Standards

- a. Facade Design
  - i. All building facades must provide surface relief through the use of balconies, Bays, cladding, columns, corner boards, cornices, door surrounds, moldings, piers, pilasters, sills, sign bands, windows, and other architectural features that either recess or project from the average plane of the facade by at least four (4) inches.
  - ii. Vents, exhausts, and other utility features on building facades must be architecturally integrated into the design of the building.
  - iii. Building facades, excluding apartment buildings, must provide a frame for each storefront and lobby entrance in accordance with the following architectural techniques:
    - a). A horizontal lintel or beam (architrave) and cornice that extends across the full width of the building and is supported by columns, pilasters, or piers; or
    - b). A horizontal beam or fascia (architrave) positioned between columns, pilasters, or

piers that extend from the upper stories of a building all the way to the ground.

- iv. When present, a horizontal lintel, beam, or fascia (architrave) serves as the sign band for each storefront.

## 11. Architectural Design Guidelines

- i. Reserved

**FIGURE 6.3 (a) Elements of a Storefront**

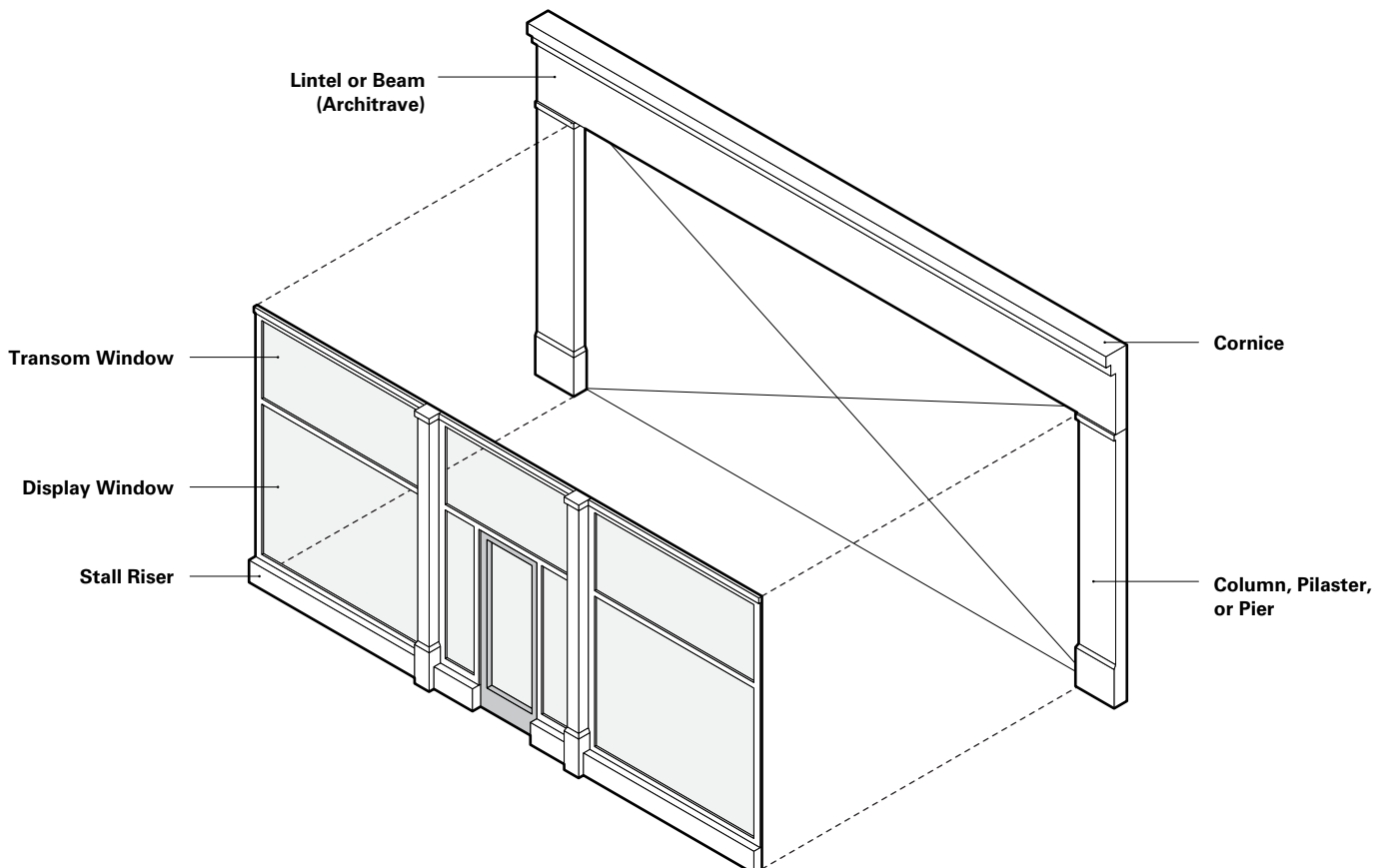

# 6.0 COMMERCIAL DISTRICTS

Commercial Industry (CI)

## 12. Use Provisions

- a. Permitted Uses
- b. Permitted Uses
  - i. The use of real property is subject to the provisions of Article 9: Use Provisions of this Ordinance. Where the provisions of this section conflict with those of Article 9, the provisions of Article 9 apply.
  - ii. Uses are permitted according to Table 6.3.12.
  - iii. All uses must comply with any use-specific standards applicable for each use in §9.2 Use Definitions & Limitations.
  - iv. Uses permitted by Special Permit require additional development review in accordance with §15.2.1 Special Permits.
  - v. Use categories not expressly authorized are prohibited.
- c. Required Uses
  - i. A minimum of five percent (5%) of the gross floor area of any commercial building or lab building must be provided as leasable floor area for uses from the arts & creative enterprise use category.

**TABLE 6.3 (a) CI Permitted Uses**

| Use Category<br>Specific Use            | CI | Use Specific<br>Standards |
|---|----|---------------------------|
| <b>Arts &amp; Creative Enterprise</b>   |    |                           |
| Artisan Production                      | P  | §9.2.2.a                  |
| Arts Exhibition                         | P  | §9.2.2.b                  |
| Arts Sales & Services                   | P  | §9.2.2.c                  |
| Co-working                              | P  | §9.2.2.d                  |
| Design Services                         | P  | §9.2.2.e                  |
| Shared Workspaces & Arts Education      | P  | §9.2.2.f                  |
| <b>Auto-Oriented</b>                    |    |                           |
| Commercial Vehicle Repair & Maintenance | SP | §9.2.3.a                  |
| Dispatch Service (except as follows)    | P  | §9.2.3.b                  |
| Towing Service                          | SP | §9.2.3.b.i                |
| Motor Vehicle Parking (as noted below)  | -- | §9.2.3.d                  |
| Off-Site Accessory Parking              | P  | §9.2.3.d.i                |
| Personal Vehicle Repair & Maintenance   | SP | §9.2.3.e                  |
| Vehicle Sales                           | SP | §9.2.3.f                  |
| <b>Civic &amp; Institutional</b>        |    |                           |
| Hospital                                | SP | §9.2.4.b                  |
| Minor Utility Facility                  | SP | §9.2.4.d                  |

P - Permitted      SP - Special Permit Required      N - Not Permitted



# 6.0 COMMERCIAL DISTRICTS

Commercial Industry (CI)

**TABLE 6.3 (a) Permitted Uses (continued)**

| Use Category<br>Specific Use                                 | CI | Use Specific Standards |
|--|----|------------------------|
| Religious & Educational Uses Protected by M.G.L. 40A. Sec. 3 | P  | §9.2.4.h               |
| <b>Commercial Services</b>                                   |    |                        |
| Animal Services (as noted below)                             | -- | §9.2.5.a               |
| Commercial Kennel  | P  | §9.2.5.a.i             |
| Pet Grooming   | P  | §9.2.5.a.ii            |
| Pet Daycare & Training                                       | P  | §9.2.5.a.iii           |
| Veterinarian   | SP | §9.2.5.a.iv            |
| Assembly & Entertainment                                     | SP | §9.2.5.b               |
| Banking & Financial Services (except as noted below)         | P  | §9.2.5.c               |
| Personal Credit  | SP | §9.2.5.c.i             |
| Broadcast and/or Recording Studio                            | P  | §9.2.5.d               |
| Building & Home Repair Services                              | P  | §9.2.5.e               |
| Business Support Services                                    | P  | §9.2.5.f               |
| Caterer/Wholesale Food Production                            | P  | §9.2.5.g               |
| Day Care Service (as noted below)                            | -- | §9.2.5.h               |
| Adult Day Care Center  | P  | §9.2.5.h.i             |
| Child Day Care Center  | P  | §9.2.5.h.ii            |
| Maintenance & Repair of Consumer Goods                       | P  | §9.2.5.j               |
| Personal Services (except as noted below)                    | P  | §9.2.5.k               |
| Body-Art Establishment                                       | P  | §9.2.5.k.i             |
| Gym or Health Club   | P  | §9.2.5.k.ii            |
| Funeral Home   | P  | §9.2.5.k.iii           |
| Health Care Provider   | SP | §9.2.5.k.iv            |
| Recreation Facility  | P  | §9.2.5.l               |
| Vehicle Parking, Commercial (except as follows)              | P  | §9.2.5.m               |
| Bike Share Parking   | P  | §9.2.5.m.i             |
| Car Share Parking (3 or less spaces)                         | P  | §9.2.5.m.ii            |
| Car Share Parking (4 or more spaces)                         | P  | §9.2.5.m.ii            |
| Public Parking   | P  | §9.2.5.m.iii           |
| <b>Eating and Drinking</b>                                   |    |                        |
| Bar/Restaurant/Tavern  | P  | §9.2.6.a               |
| Bakery/Café/Coffee Shop                                      | P  | §9.2.6.b               |
| Formula Eating & Drinking Establishment                      | SP | §9.2.6.c               |
| <b>Industrial</b>  |    |                        |
| Commercial Dry Cleaning & Laundry Services                   | SP | §9.2.7.a               |

P - Permitted      SP - Special Permit Required      N - Not Permitted

**TABLE 6.3 (a) Permitted Uses (continued)**

| Use Category<br>Specific Use                       | <b>CI</b> | Use Specific<br>Standards |
|--|-----------|---------------------------|
| Data Center  | SP        | §9.2.6.b                  |
| Manufacturing                                      | P         | §9.2.6.c                  |
| Moving and/or Self Storage (except as noted below) | P         | §9.2.6.d                  |
| Self Storage                                       | SP        | §9.2.6.d.i                |
| Recycling Collection                               | SP        | §9.2.6.e                  |
| Trucking and Transportation Depot                  | SP        | §9.2.6.g                  |
| Wholesale Trade & Distribution                     | P         | §9.2.6.h                  |
| <b>Lodging</b>                                     |           |                           |
| Hotel or Hostel                                    | SP        | §9.2.7.b                  |
| <b>Office</b>                                      |           |                           |
| General Office                                     | P         | §9.2.8.a                  |
| Research and Development and/or Laboratory         | P         | §9.2.8.b                  |
| <b>Retail Sales</b>                                |           |                           |
| Building/Home Supplies & Equipment                 | P         | §9.2.10.a                 |
| Consumer Goods (except as follows)                 | P         | §9.2.10.b                 |
| Alcohol Sales                                      | SP        | §9.2.10.b.i               |
| Drug Paraphernalia Store                           | N         | §9.2.10.b.ii              |
| Firearms Sales                                     | N         | §9.2.10.b.iii             |
| Medical Marijuana                                  | N         | §9.2.10.b.iv              |
| Pet Store  | SP        | §9.2.10.b.v               |
| Formula Retail                                     | SP        | §9.2.10.c                 |
| Fresh Food Market or Grocery Store                 | SP        | §9.2.10.d                 |
| Farm/Vendor Market                                 | P         | §9.2.10.e                 |
| <b>Urban Agriculture</b>                           |           |                           |
| Farming (as noted below)                           | --        | §9.2.11.a                 |
| Commercial Farm                                    | P         | §9.2.11.a.i               |
| Community Farm                                     | P         | §9.2.11.a.ii              |
| Community Gardening                                | P         | §9.2.11.b                 |
| <b>Accessory Uses</b>                              |           |                           |
| Urban Agriculture (as noted below)                 | --        | §9.2.12.d                 |
| Commercial Farming                                 | P         | §9.2.12.d.iii             |
| Vehicle Parking, Accessory (except as follows)     | P         | §9.2.12.e                 |
| Home Business Vehicle Parking                      | N         | §9.2.12.f                 |

P - Permitted      SP - Special Permit Required      N - Not Permitted

# 6.0 COMMERCIAL DISTRICTS

Commercial Industry (CI)

## 13. Vehicular Parking

- a. General
  - i. Vehicular parking must be provided according to Table 6.3 (b) except as follows:
    - a). Non-residential uses with five thousand (5,000) square feet or less of gross leasable floor area are exempt from any minimum requirements of Table 6.3 (b).
    - b). Any change in use within a non-residential structure constructed before the effective date of this Ordinance, provided that the change is to a permitted use, is exempt from any minimum requirements of Table 6.3 (b).
  - ii. There are no parking requirements for accessory uses.
  - iii. Motor vehicle parking spaces may be shared between uses on the same lot and buildings on the same block in accordance with §12.3 Shared Parking.
- b. Type
  - i. Motor vehicle parking may be provided as surface parking spaces, above ground structured parking, or underground structured parking.
- c. Unbundled Parking
  - i. Motor vehicle parking spaces must be rented or leased as an option rather than a requirement of the rental, lease, or purchase of a dwelling unit or non-residential floor space.
  - ii. Bicycle parking must be provided at no cost or fee to customers, visitors, employees, tenants, and residents.
- d. Parking Design
  - i. The design of all parking is subject to §12.1 Bicycle Parking and §12.2 Motor Vehicle Parking of this Ordinance.
  - ii. Driveways, curb cuts, and vehicular entrances to parking lots, parking structures, loading docks, and service areas are not permitted along primary front lot lines abutting a pedestrian street, but may provide access from a side street or alley.
  - iii. Driveways may be located within a required side and rear setback areas, but are not permitted between the facade of a building and any front lot line.
  - iv. Driveways may be no more than twenty four (24) feet in width at the frontage.
  - v. Driveways may provide access in whole or in part on or across an abutting lot(s), provided that an access easement exists between all property owners.
  - vi. Unless otherwise specified, only one (1) curb cut is permitted per front lot line.
  - vii. Curb cuts must be located to minimize conflict with pedestrians, bicyclists, and motor vehicles on the thoroughfare they provide access to and from.
  - viii. Curb cuts may be no wider than the driveway or vehicular entrance they serve, excluding flares or returned curbs.
  - ix. Driveway crossings traversing sidewalks with paved furnishing zones must be designed to maintain the grade and clear width of the walkway they cross and must include sloped flares on either side of the driveway apron.
  - x. Driveway crossings traversing sidewalks with continuously planted furnishing zones must be designed to maintain the grade and clear width of

**TABLE 6.3 (b) Vehicular Parking**

\*See Transit Orientation Map for distance to a Transit Station

| Use Category<br>Specific Use          | BICYCLE             |                    | MOTOR VEHICLE                     |                                       |
|---------------------------------------|---------------------|--------------------|-----------------------------------|---------------------------------------|
|                                       | Short-Term<br>(min) | Long-Term<br>(min) | Within a<br>Transit Area<br>(max) | Outside of a<br>Transit Area<br>(min) |
| <b>Arts &amp; Creative Enterprise</b> |                     |                    |                                   |                                       |
| Artisan Production                    | 1 / 10,000 sf       | 1 / 3,000 sf       | 1 / 800 sf                        | 1 / 1,000 sf                          |
| Arts Exhibition                       | 1 / 10,000 sf       | 1 / 3,000 sf       | 1 / 800 sf                        | 1 / 650 sf                            |
| Arts Sales & Services                 | 1 / 10,000 sf       | 1 / 3,000 sf       | 1 / 200 sf                        | 1 / 1,000 sf                          |
| Design Services                       | 1 / 10,000 sf       | 1 / 3,000 sf       | 1 / 800 sf                        | 1 / 1,000 sf                          |
| Shared Workspaces & Arts Education    | 1 / 10,000 sf       | 1 / 3,000 sf       | 1 / 800 sf                        | 1 / 650 sf                            |

sf - Gross Leasable Square Footage

DU - Dwelling Unit

RU - Rooming Unit

# 6.0 COMMERCIAL DISTRICTS

Commercial Industry (CI)

**TABLE 6.3 (b) Vehicular Parking (continued)**

\*See Transit Orientation Map for distance to a Transit Station

| Use Category<br>Specific Use                            | BICYCLE             |   | MOTOR VEHICLE                     |                                       |
|---|---------------------|---|-----------------------------------|---------------------------------------|
|   | Short-Term<br>(min) | Long-Term<br>(min)                      | Within a<br>Transit Area<br>(max) | Outside of a<br>Transit Area<br>(min) |
| <b>Civic &amp; Institutional</b>                        |                     |   |                                   |                                       |
| Community Center  | 1 / 10,000 sf       | 4 / 10,000 sf                           | 1 / 1,800 sf                      | 1 / 600 sf                            |
| Educational Facility                                    | 1.0 /<br>classroom  | 4.0 /<br>classroom                      | 1.5 /<br>classroom                | 3.0 /<br>classroom                    |
| Hospital  | 10 per<br>entrance  | 1 / 5,000 sf                            | 1 / 200 sf                        | 1 / 1,000 sf                          |
| Library   | 1 / 3,000 sf        | 1 / 5,000 sf                            | 1 / 800 sf                        | 1 / 500 sf                            |
| Minor Utility Facility                                  | n/a                 | n/a                                     | n/a                               | n/a                                   |
| Museum  | 1 / 2,000 sf        | 1 / 10,000 sf                           | 1 / 800 sf                        | 1 / 500 sf                            |
| Private Non-Profit Club or Lodge                        | 1 / 2,000 sf        | 1 / 10,000 sf                           | 1 / 200 sf                        | 1 / 1,000 sf                          |
| <b>Commercial Services</b>                              |                     |   |                                   |                                       |
| Animal Services (as noted below)                        | 1 / 2,500 sf        | 1 / 10,000 sf                           | –                                 | –                                     |
| Pet Grooming  | –                   | –                                       | 1 / 500 sf                        | 1 / 400 sf                            |
| Veterinarian  | 1 / 2,000 sf        | 1 / 5,000 sf                            | 1 / 500 sf                        | 1 / 500 sf                            |
| Assembly & Entertainment                                | 1 / 40 seats        | 1 / 10,000 sf                           | 1 / 6 seats                       | 1 / 6 seats                           |
| Banking & Financial Services<br>(except as noted below) | 1 / 2,000 sf        | 1 / 10,000 sf                           | 1 / 450 sf                        | 1 / 400 sf                            |
| Broadcast and/or Recording Studio                       | 1 / 2,500 sf        | 1 / 10,000 sf                           | 1 / 800 sf                        | 1 / 600 sf                            |
| Building & Home Repair Services                         | 1 / 2,500 sf        | 1 / 10,000 sf                           | 1 / 1,000 sf                      | 1 / 2,000 sf                          |
| Business Support Services                               | 1 / 2,500 sf        | 1 / 10,000 sf                           | 1 / 900 sf                        | 1 / 600 sf                            |
| Caterer/Wholesale Food Production                       | 1 / 2,500 sf        | 1 / 10,000 sf                           | 1 / 800 sf                        | 1 / 1,000 sf                          |
| Day Care Service  | 2                   | 1 / 10,000 sf                           | 1 / 900 sf                        | 1 / 600 sf                            |
| Maintenance & Repair of Consumer Goods                  | 1 / 2,500 sf        | 1 / 10,000 sf                           | 1 / 750 sf                        | 1 / 1,000 sf                          |
| Personal Services (except as noted below)               | 1 / 2,500 sf        | 1 / 10,000 sf                           | 1 / 750 sf                        | 1 / 1,000 sf                          |
| Gym or Health Club                                      |                     |   | 1 / 200 sf                        | 1 / 500 sf                            |
| Funeral Home  |                     |   |                                   |                                       |
| Health Care Provider                                    | 1 / 2,000 sf        | 1 / 10,000 sf                           | 1 / 500 sf                        | 1 / 300 sf                            |
| Recreation Facility                                     | 1 / 2,500 sf        | 1 / 10,000 sf                           |                                   |                                       |
| Vehicle Parking   | n/a                 | 10 or 1 / 10<br>motor vehicle<br>spaces | n/a                               | n/a                                   |

sf - Gross Leasable Square Footage

DU - Dwelling Unit

RU - Rooming Unit

# 6.0 COMMERCIAL DISTRICTS

Commercial Industry (CI)

**TABLE 6.3 (b) Vehicular Parking (continued)**

\*See Transit Orientation Map for distance to a Transit Station

| Use Category<br>Specific Use               | BICYCLE             |                    | MOTOR VEHICLE                     |                                       |
|--|---------------------|--------------------|-----------------------------------|---------------------------------------|
|  | Short-Term<br>(min) | Long-Term<br>(min) | Within a<br>Transit Area<br>(max) | Outside of a<br>Transit Area<br>(min) |
| <b>Eating and Drinking</b>                 |                     |                    |                                   |                                       |
| Bar/Restaurant/Tavern                      | 1 / 1,000 sf        | 1 / 5,000 sf       | 1 / 300 sf                        | 1 / 500 sf                            |
| Bakery/Café/Coffee Shop                    | 1 / 1,000 sf        | 1 / 5,000 sf       | 1 / 300 sf                        | 1 / 500 sf                            |
| Formula Eating & Drinking Establishment    | 1 / 1,000 sf        | 1 / 5,000 sf       | 1 / 300 sf                        | 1 / 500 sf                            |
| <b>Lodging</b>                             |                     |                    |                                   |                                       |
| Bed & Breakfast                            | 1 / 20 rooms        | 1 / 10 rooms       | 1 / DU + 1 / 4<br>guest rooms     | 1 / DU + 1 / 4<br>guest rooms         |
| Hotel or Hostel                            | 1 / 20 rooms        | 1 / 10 rooms       | 1 / 2 guest<br>rooms              | 1 / 2 guest<br>rooms                  |
| <b>Office</b>                              |                     |                    |                                   |                                       |
| Co-Working                                 | 1 / 20,000 sf       | 1 / 3,000 sf       | 1 / 1,200 sf                      | 1 / 800 sf                            |
| General Office                             | 1 / 20,000 sf       | 1 / 3,000 sf       | 1 / 900 sf                        | 1 / 650 sf                            |
| Research and Development and/or Laboratory | 1 / 20,000 sf       | 1 / 5,000 sf       | 1 / 1,000 sf                      | 1 / 1,000 sf                          |
| <b>Residential</b>                         |                     |                    |                                   |                                       |
| Household Living                           | 0.1 / DU            | 1.0 / DU           | 1.0 / DU                          | 1.0 / DU                              |
| Group Living<br>(except as follows)        | 0.05 / room         | 0.5 / room         | –                                 | –                                     |
| Community or Group Residence               |                     |                    |                                   |                                       |
| Dormitory, Fraternity or Sorority          | 0.1 / room          | 0.5 / room         | .05 / bed                         | 1.0 / 4 beds                          |
| Homeless Shelter                           |                     |                    | 4.0                               | 4.0                                   |
| Nursing Home/Assisted Living Facility      |                     |                    | 1 / 6 beds                        | 1 / 6 beds                            |
| Single Room Occupancy Housing              |                     |                    | 1 / 6 beds                        | 1 / 4 beds                            |
| <b>Retail Sales</b>                        |                     |                    |                                   |                                       |
| Building/Home Supplies & Equipment         | 1 / 2,500 sf        | 1 / 10,000 sf      | 1 / 1,000 sf                      | 1 / 1,000 sf                          |
| Consumer Goods (except as follows)         | 1 / 2,500 sf        | 1 / 10,000 sf      | 1 / 1,500 sf                      | 1 / 750 sf                            |
| Packaged Liquor                            |                     |                    |                                   |                                       |
| Medical Marijuana                          |                     |                    |                                   |                                       |
| Pet Store                                  |                     |                    |                                   |                                       |
| Formula Retail                             | 1 / 2,500 sf        | 1 / 10,000 sf      | 1 / 1,500 sf                      | 1 / 750 sf                            |
| Fresh Food Market or Grocery Store         | 1 / 1,000 sf        | 1 / 10,000 sf      | 1 / 500 sf                        | 1 / 1,500 sf                          |
| Farm/Vendor Market                         | n/a                 | n/a                | n/a                               | 1 / 1,500 sf                          |

sf - Gross Leasable Square Footage

DU - Dwelling Unit

RU - Rooming Unit

the walkway they cross and must include returned curbs.

- xi. The appearance of any walkway (ie. scoring pattern or special paving) must be maintained across any driveway or alley to indicate that, although a vehicle may cross, the area traversed by a vehicle remains part of the sidewalk.
  - e. Parking Location
    - i. Required motor vehicle parking, excluding any required handicapped parking, may be provided off-site according to the following:
      - a). The off-site parking must be located within one thousand three hundred and twenty (1,320) feet in walking distance to the lot it will serve, measured from the nearest point of the off-site parking along block faces and walkways to the principal entrance of the use served;
      - b). Pedestrian access to off-site motor vehicle parking must be via a paved sidewalk or walkway.
      - c). A lease, recorded covenant, or other comparable legal instrument guaranteeing long term use of the site must be provided to the review board or building official and executed and filed with the Registry of Deeds.
    - ii. For real property located in more than one municipality, motor vehicle parking need not be located within the City of Somerville.
  - f. Parking Relief
    - i. Relief from the parking standards of Table 6.2 (b) requires a special permit.
      - a). In its discretion to approve or deny a special permit authorizing relief from the parking standards of Table 6.2 (b), the review board shall consider the following:
        - i). The supply and demand of on-street parking in the neighborhood, as determined through a parking study.
        - ii). Mobility management programs and services provided by the applicant to reduce the demand for parking.
        - iii). That parking provided in excess of any maximum permitted does not result in the increase in impervious lot area.
- nonelectrical nameplate identifying the property address is required for all real property as follows:
- a). Each ground story non-residential use must identify the street address either on the principal entrance door or above or beside the principal entrance of the use.
  - b). All residential building types must identify the street address either on the principal entrance door, above or beside the principal entrance, or on a mailbox.
- ii. Address signs must be made easily visible through the use of colors or materials that contrast with the background material they are attached to and must be conspicuously located to provide visibility from the thoroughfare that the building faces.
  - iii. Address signs must be twelve (12) inches in height or less and may include the name of the occupant.

### 14. Site Development

- a. General
  - i. Development is subject the provisions of Article 10: Site Development Standards of this Ordinance. Where the provisions of this section conflict with those of Article 10, the provisions of Article 10 apply.
- b. Signs
  - i. A sign, individual numerals or letters, or a

# 6.0 COMMERCIAL DISTRICTS

Commercial Industry (CI)



## 6.4 COMMERCIAL BUSINESS (CB)

### 1. Character Description

The Commercial Business district is characterized by large floor plate buildings up to two (2) stories in height. Buildings are typically setback by large parking lots and sites are primarily designed to accommodate automobiles. The district is entirely commercial, with concentrations of commercial services, eating & drinking establishments, and retailers.

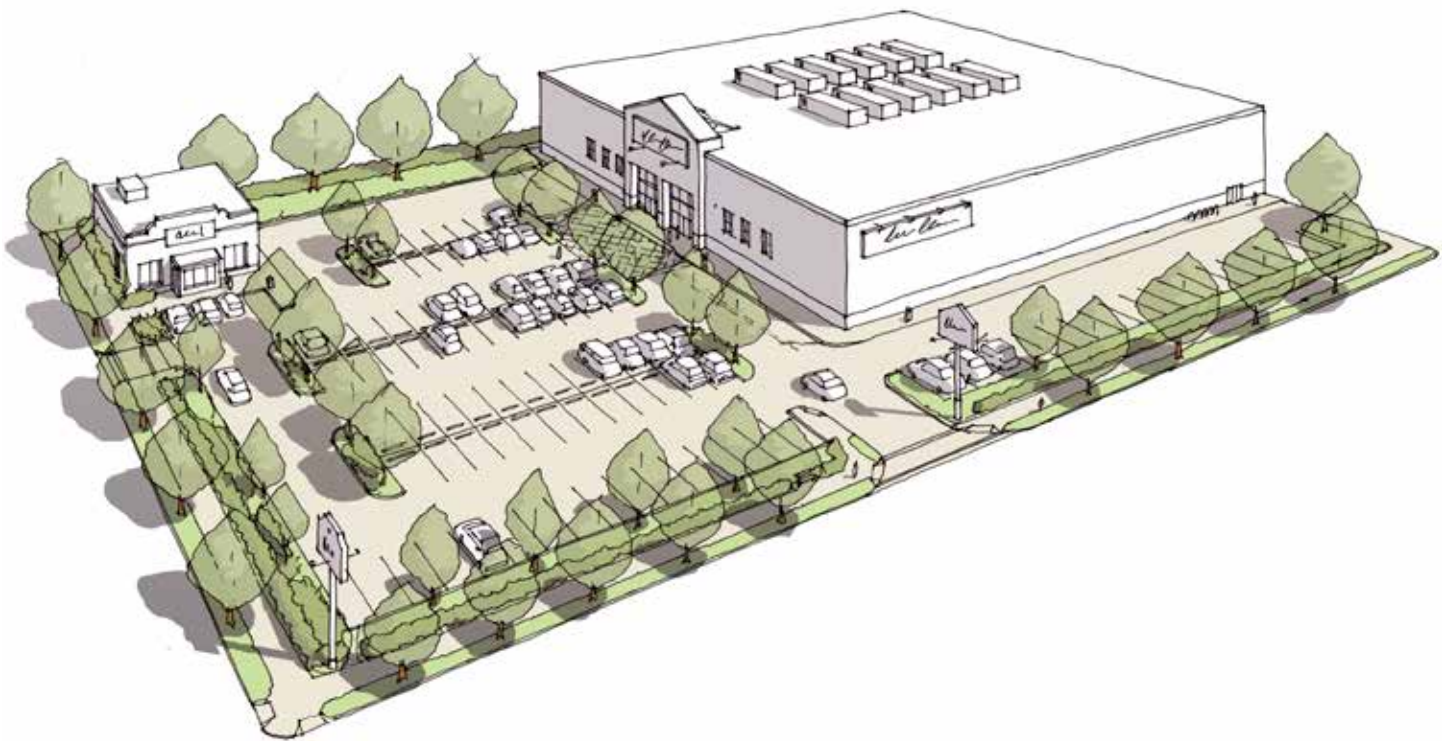

# 6.0 COMMERCIAL DISTRICTS

## Commercial Business (CB)

### 2. Intent

- a. To maintain commercial activities that are primarily accessed by motor vehicles.
- b. To maintain already existing areas appropriate for moderate- and large-scale, low-rise buildings and community- and region-serving commercial uses that do not readily assimilate into other zoning districts.

### 3. Purpose

- a. To permit the development of moderate- and large-scale low-rise buildings.
- b. To provide quality commercial spaces and permit commercial uses.

### 4. Applicability

- a. The section is applicable to all real property within the Commercial Business district as shown in the Official Zoning Atlas of the City of Somerville.

### 5. Standards & Measurements

- a. General
  - i. Notwithstanding the defined terms of Article 16: Definitions, the facade of any principal building type shall be designated by the Planning Director.
  - ii. If such a designation causes a building to orient away from the thoroughfare its lot is abutting, the front and rear setbacks are also reoriented.

### 6. Development Review

- a. Development on any lot requires the submittal of a development review application to the Building Official and the issuance of a Zoning Compliance Certificate.
- b. Proposed development may or may not necessitate the need for Site Development Plan Approval, a Special Permit, or a Variance based on the nature of the proposal. In such cases, additional development review is required in accordance with Article 15: Administration.
  - i. The Zoning Board of Appeals is the decision making authority for all development in the Commercial Business district.
- c. Upon verification that no additional development review is necessary or completion of the required development review, a Zoning Compliance Certificate shall be issued by the Building Official to certify compliance with the provisions and procedures of this Ordinance.

### 7. Building Types

- a. One (1) principal building type may be built on each lot.
- b. The following building types are permitted by Site Development Plan Approval in the High-Rise district:
  - i. Box Building
  - ii. Strip Commerce
  - iii. Pad Commerce
- c. Accessory structures are regulated according to Article 10: Development Standards of this Ordinance.

## 8. Box Building

A free-standing, low-rise, large floor plate, usually single tenant building type that is frequently setback by motor vehicle parking.

The following images are examples of the box building type and are intended only for illustrative purposes.



# 6.0 COMMERCIAL DISTRICTS

Commercial Business (CB)

## 8. Box Building (continued)

a. Lot Standards

b. Building Placement

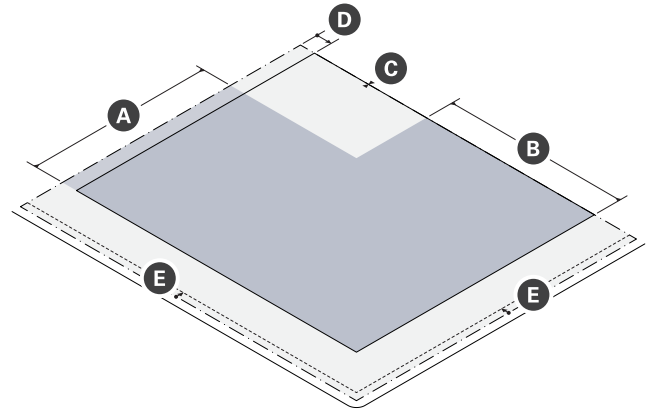
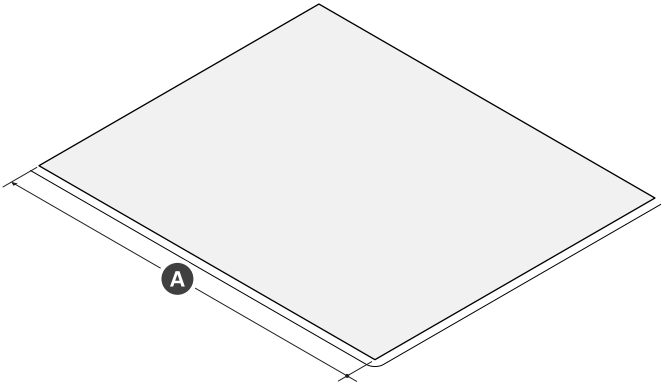

| Lot Dimensions       |        |
|----------------------|--------|
| <b>A</b> Width (max) | 800 ft |

| Lot Development             |      |
|-----------------------------|------|
| <b>B</b> Lot Coverage (max) | 75%  |
| <b>C</b> Green Factor (min) | 0.20 |

| Building Setbacks                          |              |
|--|--------------|
| <b>A</b> Primary Front Setback (min/max)   | 60 ft 300 ft |
| <b>B</b> Secondary Front Setback (min/max) | 10 ft 300 ft |
| <b>C</b> Side Setback (min)                | 0 ft         |
| Side Setback Abutting NR or LHD (min)      | 50 ft        |
| <b>D</b> Rear Setback (min)                | 20 ft        |
| Rear Setback Abutting NR or LHD (min)      | 50 ft        |

| Parking Setbacks             |       |
|------------------------------|-------|
| <b>E</b> Front Setback (min) | 10 ft |

## 8. Box Building (continued)

c. Height & Massing

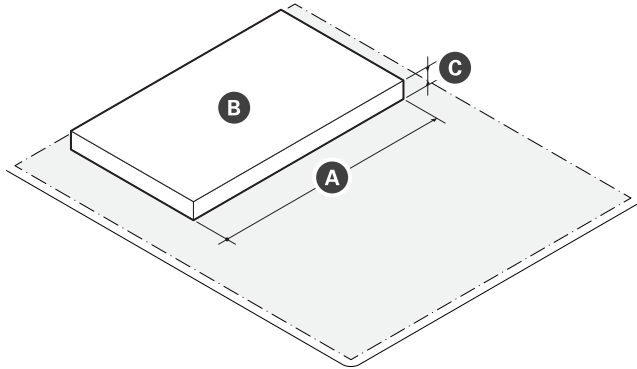

d. Uses & Features

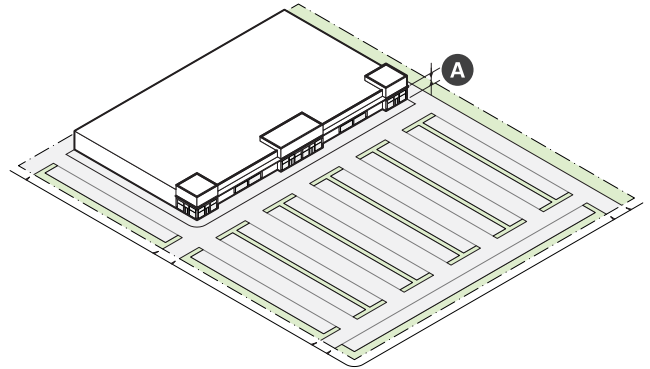

### Main Body

|   |           |
|---|-----------|
| <b>A</b> Building Width (max)           | 400 ft    |
| <b>B</b> Floor Plate (max)              | 65,000 sf |
| <b>C</b> Building Height, Stories (max) | 1 story   |
| Building Height, Feet (max)             | 50 ft     |

### Facade Composition

|  |       |
|--|-------|
| <b>A</b> Ground Story Fenestration (min) | 50%   |
| Blank Wall (max)                         | 50 ft |

### Use & Occupancy

|                                     |        |
|-------------------------------------|--------|
| Ground Story Entrance Spacing (max) | 200 ft |
|-------------------------------------|--------|

## 6.0 COMMERCIAL DISTRICTS

Commercial Business (CB)

- e. Building Design Standards
  - i. Reserved
- f. Architectural Design Guidelines
  - i. Reserved



## 9. Strip Commerce

A low rise, large floor plate, multi-tenant building type that is frequently setback by motor vehicle parking. Commercial tenants, typically retail or office uses, are oriented side-by-side. Second floors are uncommon, but permitted.

The following images are examples of the strip commerce building type and are intended only for illustrative purposes.



# 6.0 COMMERCIAL DISTRICTS

Commercial Business (CB)

## 9. Strip Commerce (continued)

a. Lot Standards

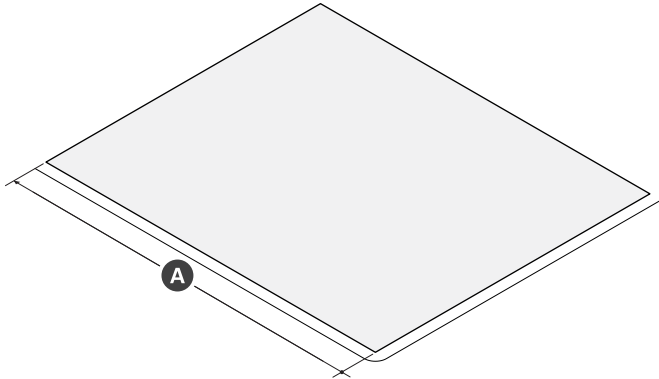

| Lot Dimensions       |        |
|----------------------|--------|
| <b>A</b> Width (max) | 400 ft |

| Lot Development             |      |
|-----------------------------|------|
| <b>B</b> Lot Coverage (max) | 75%  |
| <b>C</b> Green Factor (min) | 0.20 |

b. Building Placement

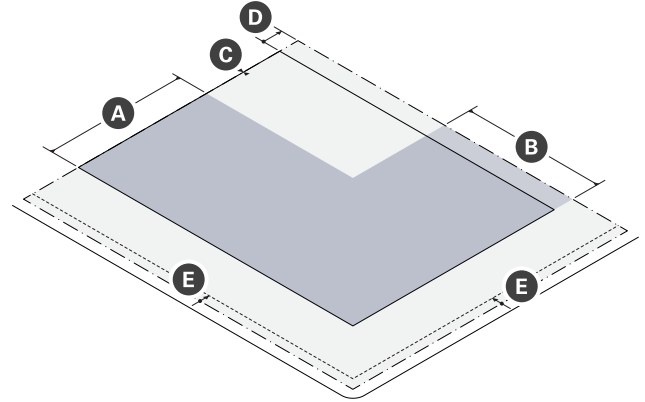

| Building Setbacks                          |       |        |
|--|-------|--------|
| <b>A</b> Primary Front Setback (min/max)   | 60 ft | 200 ft |
| <b>B</b> Secondary Front Setback (min/max) | 10 ft | 200 ft |
| <b>C</b> Side Setback (min)                | 0 ft  |        |
| Side Setback Abutting NR or LHD (min)      | 50 ft |        |
| <b>D</b> Rear Setback (min)                | 20 ft |        |
| Rear Setback Abutting NR or LHD (min)      | 50 ft |        |

| Parking Setbacks             |       |
|------------------------------|-------|
| <b>E</b> Front Setback (min) | 10 ft |



## 9. Strip Commerce (continued)

c. Height & Massing

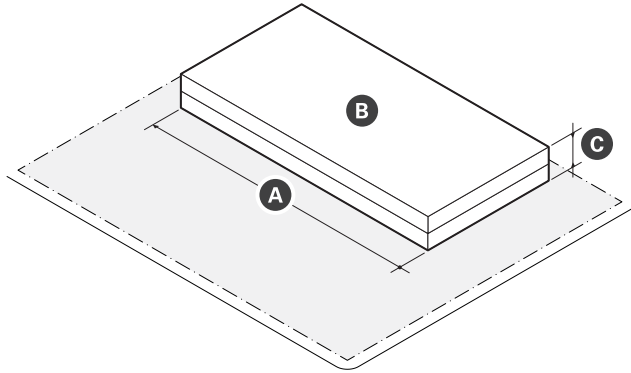

| Main Body                               |           |
|---|-----------|
| <b>A</b> Building Width (max)           | 400 ft    |
| <b>B</b> Floor Plate (max)              | 65,000 sf |
| <b>C</b> Building Height, Stories (max) | 2 stories |
| Building Height, Feet (max)             | 50 ft     |

d. Uses & Features

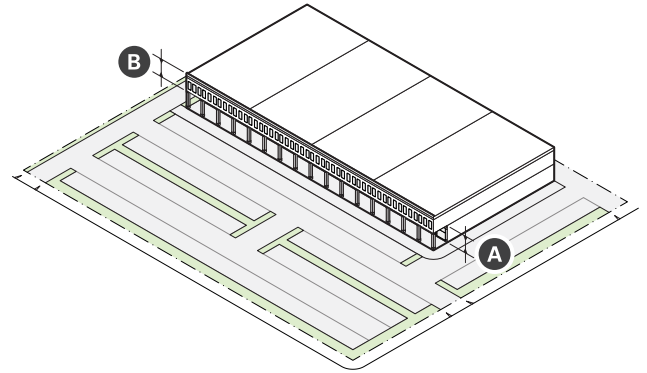

| Facade Composition                          |         |
|---|---------|
| <b>A</b> Ground Story Fenestration (min)    | 50%     |
| <b>B</b> Upper Story Fenestration (min/max) | 20% 70% |
| Blank Wall (max)                            | 20 ft   |

| Use & Occupancy                     |       |
|-------------------------------------|-------|
| Ground Story Entrance Spacing (max) | 30 ft |
| Commercial Space Depth (min)        | 30 ft |

## 6.0 COMMERCIAL DISTRICTS

Commercial Business (CB)

- e. Building Design Standards
  - i. Reserved
- f. Architectural Design Guidelines
  - i. Reserved

## 10. Pad Commerce

A low rise, small floor plate, one- to two-tenant building type on a freestanding lot typically located in front or to the side of a box building or strip commerce building type.

The following images are examples of the pad commerce building type and are intended only for illustrative purposes.



# 6.0 COMMERCIAL DISTRICTS

Commercial Business (CB)

## 10. Pad Commerce (continued)

a. Lot Standards

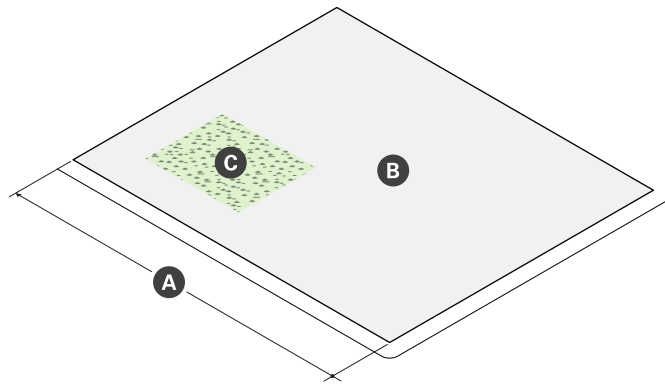

| Lot Dimensions       |        |
|----------------------|--------|
| <b>A</b> Width (max) | 250 ft |

| Lot Development             |      |
|-----------------------------|------|
| <b>B</b> Lot Coverage (max) | 75%  |
| <b>C</b> Green Factor (min) | 0.20 |

b. Building Placement

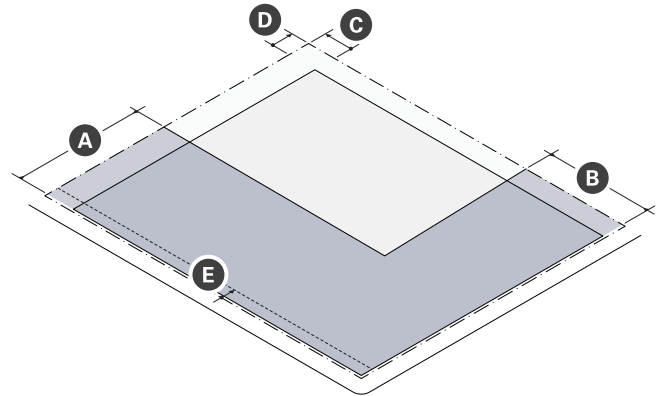

| Building Setbacks                          |       |       |
|--|-------|-------|
| <b>A</b> Primary Front Setback (min/max)   | 2 ft  | 75 ft |
| <b>B</b> Secondary Front Setback (min/max) | 2 ft  | 40 ft |
| <b>C</b> Side Setback (min)                | 15 ft |       |
| Side Setback Abutting NR or LHD (min)      | 50 ft |       |
| <b>D</b> Rear Setback (min)                | 20 ft |       |
| Rear Setback Abutting NR or LHD (min)      | 50 ft |       |

| Parking Setbacks             |       |
|------------------------------|-------|
| <b>E</b> Front Setback (min) | 10 ft |

## 10. Pad Commerce (continued)

c. Height & Massing

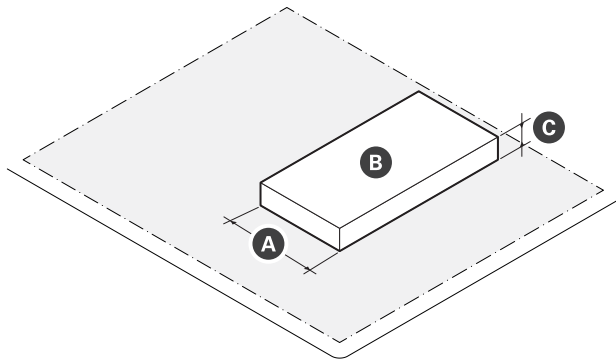

d. Uses & Features

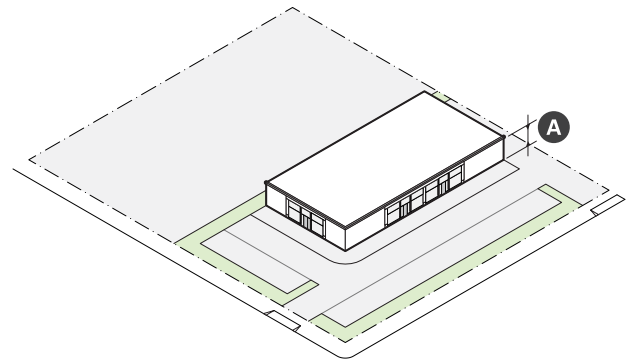

| Main Body                               |           |
|---|-----------|
| <b>A</b> Building Width (max)           | 100 ft    |
| <b>B</b> Floor Plate (max)              | 10,000 sf |
| <b>C</b> Building Height, Stories (max) | 1 story   |
| Building Height, Feet (max)             | 25 ft     |

| Facade Composition                       |       |
|--|-------|
| <b>A</b> Ground Story Fenestration (min) | 70%   |
| Blank Wall (max)                         | 20 ft |

## 6.0 COMMERCIAL DISTRICTS

Commercial Business (CB)

- e. Building Design Standards
  - i. Reserved
- f. Architectural Design Guidelines
  - i. Reserved

## 11. Building Components

- a. Building components are accessory features that increase the habitable square footage or enhance the usefulness of a building.
- b. The following building frontage types are permitted in the Commercial Business (CB) district:
  - i. Awning (See §6.11.d)
  - ii. Entry Canopy (See §6.11.e)
- c. Building components not expressly authorized are prohibited.

## D. Awning

- i. A wall mounted, pitched covering extending from a building to provide shade and weather protection for pedestrians.

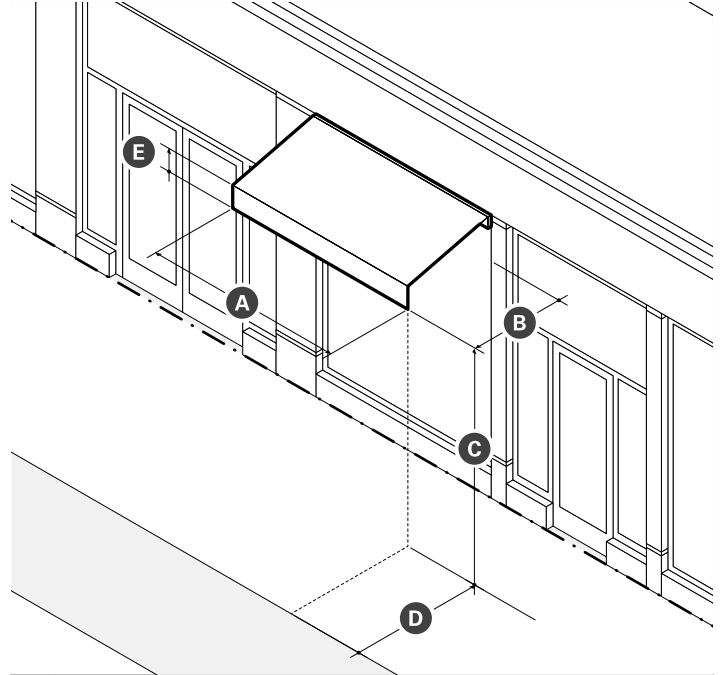

| Dimensions                       |            |
|----------------------------------|------------|
| <b>A</b> Width (min)             | See §X     |
| <b>B</b> Projection (min)        | 3 ft       |
| <b>C</b> Clearance (min)         | 8 ft clear |
| <b>D</b> Setback from Curb (min) | 1.5 ft     |
| <b>E</b> Valance Height (max)    | 12 in      |

- ii. Standards
  - a). Awnings must be securely attached to and supported by the building, and must fit the windows or doors the awning is attached to.
  - b). An awning must be made of durable, weather-resistant material that is water repellent.
  - c). Internally illuminated or back-lit awnings are prohibited.
  - d). An awning that projects over the sidewalk of a public thoroughfare requires compliance with all City Ordinances.

# 6.0 COMMERCIAL DISTRICTS

Commercial Business (CB)

## E. Entry Canopy

- i. An entry canopy is a wall-mounted structure that provides shade and weather protection over the entrance of a building.

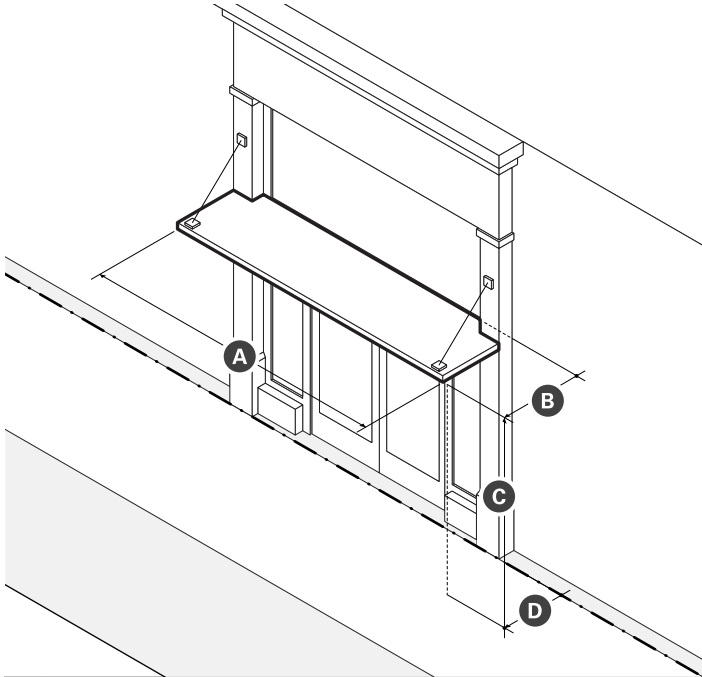

| Dimensions                                    |            |
|---|------------|
| <b>A</b> Width (min)                          | See §X     |
| <b>B</b> Depth (max)                          | 3 ft       |
| <b>C</b> Clearance (min)                      | 8 ft clear |
| <b>D</b> Permitted Setback Encroachment (max) | 100%       |

- ii. Standards
  - a). Entry canopies must be visually supported by brackets, cables, or rods.
  - b). The width of an entry canopy must be equal to or greater than the width of the doorway surround or exterior casing it is mounted over.



## 12. Private Frontage

- a. Private frontage must be designed as a building frontage type.
- b. Building frontage types facilitate access to principal entrances and serve as the interface and transition between the private realm (building interiors) and the public realm (sidewalks and civic spaces).
- c. The following building frontage types are permitted in the Commercial Business (CB) district:
  - i. Forecourt (See §6.12.e)
  - ii. Lobby Entrance (See §6.12.f)
  - iii. Storefront (See §6.12.g)
  - iv. Terrace (See §6.12.h)
  - v. Arcade (See §6.12.i)
- d. Building frontage types may be combined as indicated for each type and multiple frontage types may exist for buildings that have more than one principal entrance.

## E. Forecourt

- i. A forecourt is a frontage type featuring a landscaped semi-public area, open to the sky, formed by a recess in a central portion of a building's facade.

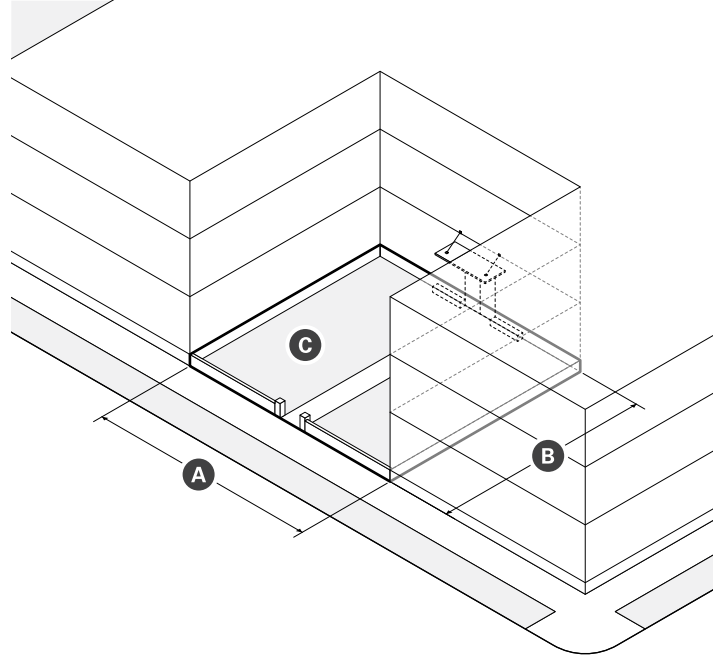

| Dimensions                     |        |
|--------------------------------|--------|
| <b>A</b> Width (min)           | 12 ft  |
| <b>B</b> Depth (min)           | 12 ft  |
| Height to Width Ratio (max)    | 2 to 1 |
| <b>C</b> Landscaped Area (min) | 30%    |

- ii. Standards
  - a). Paving, excluding driveways, must match the abutting sidewalk unless paved with permeable paving.
  - b). Forecourts are considered part of the building for the purpose of measuring facade build out.
  - c). A forecourt must be enclosed by walls on three sides.
  - d). Porches, stoops, porticos, entry canopies, and balconies may encroach into the forecourt.
  - e). Driveways, parking spaces, passenger drop-offs, garage entrances, loading and service areas, exhaust vents, mechanical equipment, and refuse or recycling storage are not permitted in forecourts.

# 6.0 COMMERCIAL DISTRICTS

Commercial Business (CB)

## F. Lobby Entrance

- i. A lobby entrance is a frontage type featuring a non-load bearing assembly of entry doors and windows providing access and light to the lobby of a building.

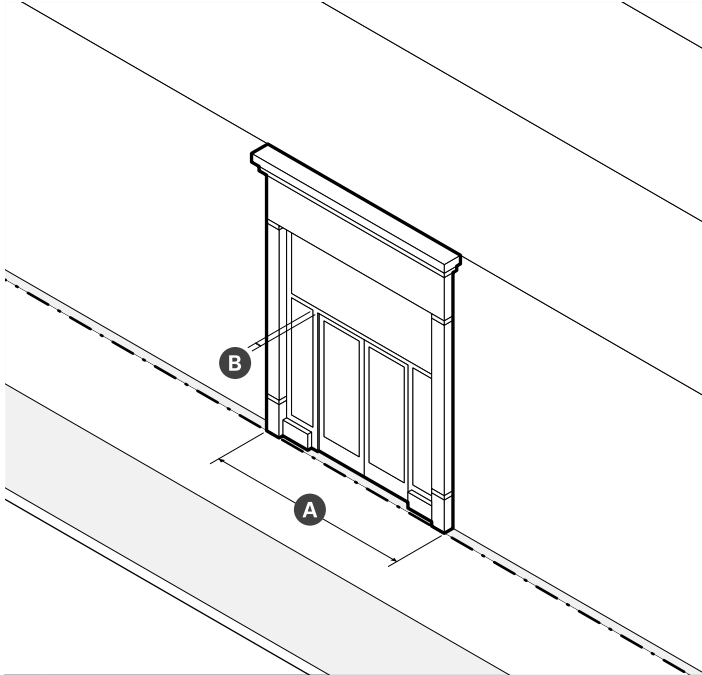

| Dimensions                                   |       |
|--|-------|
| <b>A</b> Width (max)                         | 20 ft |
| <b>B</b> Distance between Fenestration (max) | 2 ft  |
| Depth of Recessed Entry (max)                | 5 ft  |

- ii. Standards
  - a). Lobby entrances must be well-defined, clearly visible, and universally accessible from the abutting sidewalk.
  - b). When a lobby entrance is setback from the front lot line, the frontage must be paved to match the abutting sidewalk.
  - c). Lobby entrances should be made clearly identifiable using a difference in design from the rest of the facade.
  - d). Lobby entrances should include weather protection.

## G. Storefront

- i. A storefront is a frontage type featuring a non-load bearing assembly of commercial entry doors and substantial windows for the display of goods, services, and signs.

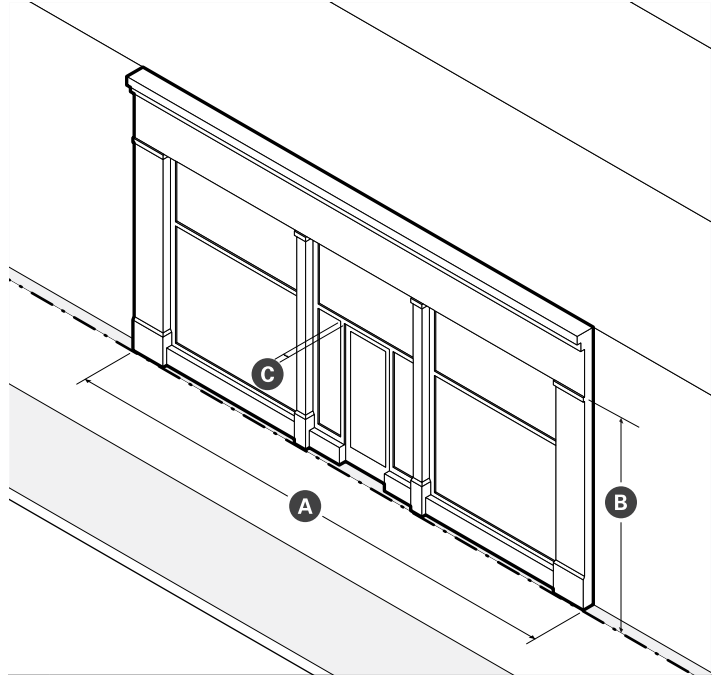

| Dimensions                                   |       |
|--|-------|
| <b>A</b> Width (max)                         | 30 ft |
| <b>B</b> Display Window Height (min)         | 8 ft  |
| <b>C</b> Distance between Fenestration (max) | 2 ft  |
| Depth of Recessed Entry (max)                | 5 ft  |

- ii. Standards
  - a). When storefronts are setback from the front lot line, the frontage must be paved to match the abutting sidewalk.
  - b). Open-ended, operable awnings are encouraged for weather protection.
  - c). Bi-fold glass windows and doors and other storefront systems that open to permit a flow of customers between interior and exterior space are encouraged.

## H. Terrace

- i. A terrace is a frontage type featuring an elevation of the ground level to accommodate a change in grade that provides circulation and access along the front of a building.

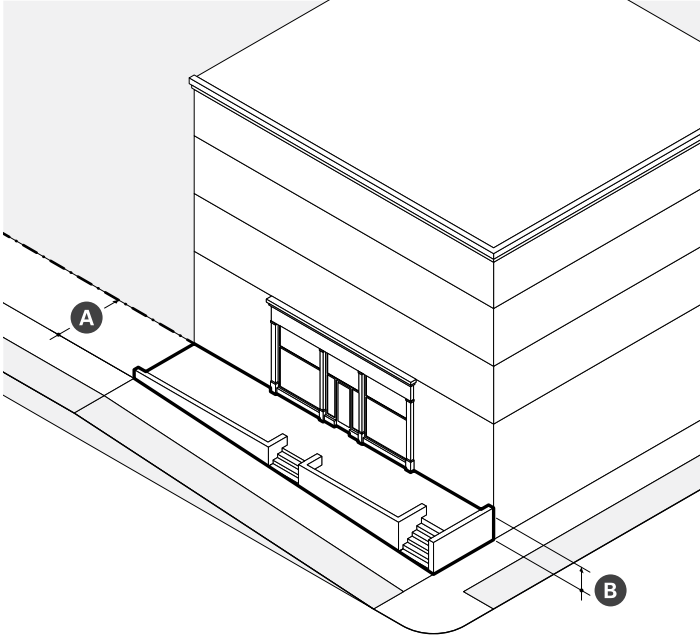

| Dimensions                               |       |      |
|--|-------|------|
| <b>A</b> Depth (min)                     | 20 ft |      |
| <b>B</b> Finish above Sidewalk (min/max) | 18 in | 4 ft |
| Distance between Stairs (max)            | 50 ft |      |

- ii. Standards
  - a). Terrace frontage must be paved to match the abutting sidewalk.
  - b). Frequent steps up to the terrace are required to avoid blank wall along the sidewalk and maximize pedestrian access.

## I. Arcade

- i. An arcade is a frontage type featuring a pedestrian walkway covered by the upper floors of a building. The ground story facade is setback and upper floors are supported by a colonnade or supports.

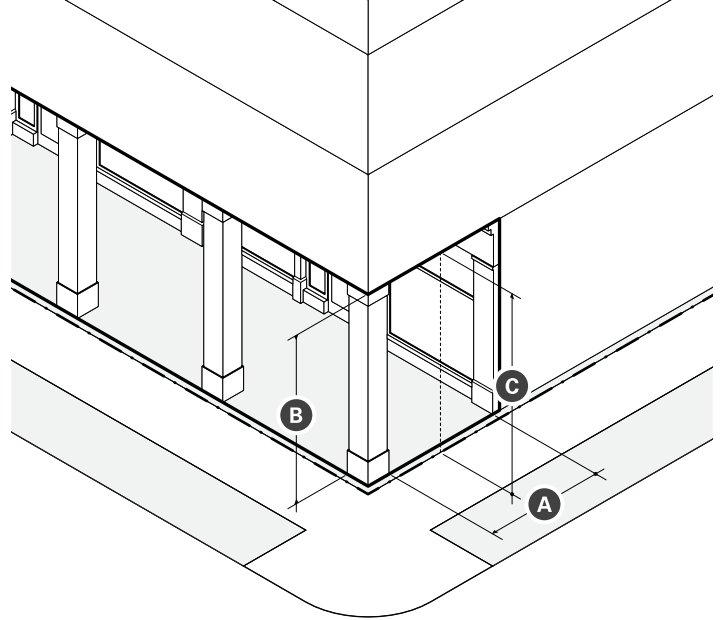

| Dimensions                   |         |       |
|------------------------------|---------|-------|
| <b>A</b> Depth (min/max)     | 10 ft   | W ft  |
| <b>B</b> Height (max)        | 1 story |       |
| <b>C</b> Clearance (min/max) | 14 ft   | 24 ft |

- ii. Standards
  - a). Arcades must extend the entire width of a building and must have a consistent depth.
  - b). Support columns or piers may be spaced no farther apart than they are tall.
  - c). Arcades are considered part of the building for the purpose of measuring facade build out.
  - d). Arcades may be combined only with storefront and lobby entrance frontages
  - e). The finished ceiling of an arcade interior may be arched or flat, but must have a greater clearance than the openings between columns or piers.

# 6.0 COMMERCIAL DISTRICTS

## Commercial Business (CB)

### 13. Use Provisions

- a. Permitted Uses
  - i. The use of real property is subject to the provisions of Article 9: Use Provisions of this Ordinance. Where the provisions of this section conflict with those of Article 9, the provisions of Article 9 apply.
  - ii. Uses are permitted as specified on Table 6.4 (a).
  - iii. Use categories not expressly authorized are prohibited.
  - iv. All uses must comply with any use-specific standards applicable for each use in §9.2 Use Definitions & Limitations.
  - v. Uses permitted by Special Permit require additional development review in accordance with §15.2.1 Special Permits.
- b. Required Uses
  - i. A minimum of five percent (5%) of the gross floor area of any Commercial Building or Lab Building must be provided as leasable floor area for uses from the Arts & Creative Enterprise use category.

**TABLE 6.4 (a) Permitted Uses**

| Use Category<br>Specific Use                                 | CB | Use Specific<br>Standards |
|--|----|---------------------------|
| <b>Arts &amp; Creative Enterprise</b>                        |    |                           |
| Artisan Production   | P  | §9.2.2.a                  |
| Arts Exhibition  | P  | §9.2.2.b                  |
| Arts Sales & Services  | P  | §9.2.2.c                  |
| Co-working   | P  | §9.2.2.d                  |
| Design Services  | P  | §9.2.2.e                  |
| Shared Workspaces & Arts Education                           | P  | §9.2.2.f                  |
| <b>Auto-Oriented</b>   |    |                           |
| Commercial Vehicle Repair & Maintenance                      | P  | §9.2.3.a                  |
| Dispatch Service (except as follows)                         | P  | §9.2.3.b                  |
| Towing Service   | SP | §9.2.3.b.i                |
| Motor Vehicle Parking (as noted below)                       | -- | §9.2.3.d                  |
| Off-Site Accessory Parking                                   | P  | §9.2.3.d.i                |
| Personal Vehicle Repair & Maintenance                        | SP | §9.2.3.e                  |
| Vehicle Sales  | SP | §9.2.3.f                  |
| <b>Civic &amp; Institutional</b>                             |    |                           |
| Minor Utility Facility                                       | SP | §9.2.4.d                  |
| Religious & Educational Uses Protected by M.G.L. 40A. Sec. 3 | P  | §9.2.4.h                  |
| <b>Commercial Services</b>                                   |    |                           |
| Animal Services (as noted below)                             | -- | §9.2.5.a                  |
| Commercial Kennel  | P  | §9.2.5.a.i                |
| Pet Grooming   | P  | §9.2.5.a.ii               |
| Pet Day Care & Training                                      | P  | §9.2.5.a.iii              |
| Veterinarian   | P  | §9.2.5.a.iv               |
| Assembly & Entertainment                                     | SP | §9.2.5.b                  |
| Banking & Financial Services (except as noted below)         | P  | §9.2.5.c                  |
| Personal Credit  | SP | §9.2.5.c.i                |
| Broadcast and/or Recording Studio                            | P  | §9.2.5.d                  |
| Building & Home Repair Services                              | P  | §9.2.5.e                  |
| Business Support Services                                    | P  | §9.2.5.f                  |
| Caterer/Wholesale Food Production                            | P  | §9.2.5.g                  |
| Day Care Service<br>(as noted below)                         | -- | §9.2.5.h                  |
| Adult Day Care Center  | P  | §9.2.5.h.i                |

P - Permitted      SP - Special Permit Required      N - Not Permitted

# 6.0 COMMERCIAL DISTRICTS

Commercial Business (CB)

**TABLE 6.4 (a) Permitted Uses**

| Use Category<br>Specific Use                       | CB | Use Specific<br>Standards |
|--|----|---------------------------|
| Child Day Care Center                              | P  | §9.2.5.h.ii               |
| Maintenance & Repair of Consumer Goods             | P  | §9.2.5.j                  |
| Personal Services (except as noted below)          | P  | §9.2.5.k                  |
| Body-Art Establishment                             | P  | §9.2.5.k.i                |
| Gym or Health Club                                 | P  | §9.2.5.k.ii               |
| Funeral Home                                       | P  | §9.2.5.k.iii              |
| Health Care Provider                               | SP | §9.2.5.k.iv               |
| Recreation Facility                                | P  | §9.2.5.l                  |
| Vehicle Parking, Commercial (except as follows)    | P  | §9.2.5.m                  |
| Bike Share Parking                                 | P  | §9.2.5.m.i                |
| Car Share Parking (3 or less)                      | P  | §9.2.5.m.ii               |
| Car Share Parking (4 or more)                      | P  | §9.2.5.m.ii               |
| Public Parking                                     | P  | §9.2.5.m.iii              |
| <b>Eating and Drinking</b>                         |    |                           |
| Bar/Restaurant/Tavern                              | P  | §9.2.6.a                  |
| Bakery/Café/Coffee Shop                            | P  | §9.2.6.b                  |
| Formula Eating & Drinking Establishment            | P  | §9.2.6.c                  |
| <b>Industrial</b>                                  |    |                           |
| Moving and/or Self Storage (except as noted below) | N  | §9.2.6.d                  |
| Self Storage                                       | SP | §9.2.6.d.i                |
| <b>Lodging</b>                                     |    |                           |
| Hotel or Hostel                                    | SP | §9.2.7.b                  |
| <b>Office</b>                                      |    |                           |
| General Office                                     | P  | §9.2.8.a                  |
| Research and Development and/or Laboratory         | P  | §9.2.8.b                  |
| <b>Retail Sales</b>                                |    |                           |
| Building/Home Supplies & Equipment                 | P  | §9.2.10.a                 |
| Consumer Goods (except as follows)                 | P  | §9.2.10.b                 |
| Alcohol Sales                                      | SP | §9.2.10.b.i               |
| Drug Paraphernalia Store                           | N  | §9.2.10.b.ii              |
| Firearms Sales                                     | N  | §9.2.10.b.iii             |
| Medical Marijuana                                  | N  | §9.2.10.b.iv              |
| Pet Store  | SP | §9.2.10.b.v               |
| Formula Retail                                     | P  | §9.2.10.c                 |

P - Permitted      SP - Special Permit Required      N - Not Permitted

**TABLE 6.4 (a) Permitted Uses**

| Use Category<br>Specific Use       | CB | Use Specific<br>Standards |
|------------------------------------|----|---------------------------|
| Fresh Food Market or Grocery Store | P  | §9.2.10.d                 |
| Farm/Vendor Market                 | P  | §9.2.10.e                 |
| <b>Urban Agriculture</b>           |    |                           |
| Farming (as noted below)           | -- | §9.2.11.a                 |
| Commercial Farm                    | P  | §9.2.11.a.i               |
| Community Farm                     | P  | §9.2.11.a.ii              |
| Community Gardening                | P  | §9.2.11.b                 |
| <b>Accessory Uses</b>              |    |                           |
| Urban Agriculture (as noted below) | -- | §9.2.12.d                 |
| Commercial Farming                 | P  | §9.2.12.d.iii             |

P - Permitted      SP - Special Permit Required      N - Not Permitted

# 6.0 COMMERCIAL DISTRICTS

## Commercial Business (CB)

### 14. Vehicular Parking

- a. General
    - i. Vehicular parking must be provided according to Table 6.4.14 except as follows:
      - a). Non-residential uses with five thousand (5,000) square feet or less of gross leasable floor area are exempt from any minimum requirements of Table 6.4.14.
      - b). Any change in use within a non-residential structure constructed before the effective date of this Ordinance, provided that the change is to a permitted use, is exempt from any minimum requirements of Table 6.4.14.
    - ii. There are no parking requirements for accessory uses.
    - iii. Motor vehicle parking spaces may be shared between uses on the same lot and buildings on the same block in accordance with §12.3 Shared Parking.
  - b. Type
    - i. Motor vehicle parking may be provided as surface parking spaces, above ground structured parking, or underground structured parking.
  - c. Unbundled Parking
    - i. Motor vehicle parking spaces must be rented or leased as an option rather than a requirement of the rental, lease, or purchase of non-residential floor space.
    - ii. Bicycle parking must be provided at no cost or fee to customers, visitors, employees, tenants, and residents.
  - d. Parking Design
    - i. The design of all parking is subject to §12.1 Bicycle Parking and §12.2 Motor Vehicle Parking of this Ordinance.
    - ii. Driveways, curb cuts, and vehicular entrances to parking lots, parking structures, loading docks, and service areas are not permitted along primary front lot lines abutting a pedestrian street, but may provide access from a side street or alley.
    - iii. Driveways may be located within a required side and rear setback areas, but are not permitted between the facade of a building and any front lot line.
    - iv. Driveways may be no more than twenty four (24) feet in width at the frontage.
    - v. Driveways may provide access in whole or in part on or across an abutting lot(s), provided that an access easement exists between all property owners.
    - vi. Unless otherwise specified, only one (1) curb cut is permitted per front lot line.
    - vii. Curb cuts must be located to minimize conflict with pedestrians, bicyclists, and motor vehicles on the thoroughfare they provide access to and from.
  - viii. Curb cuts may be no wider than the driveway or vehicular entrance they serve, excluding flares or returned curbs.
  - ix. Driveway crossings traversing sidewalks with paved furnishing zones must be designed to maintain the grade and clear width of the walkway they cross and must include sloped flares on either side of the driveway apron.
  - x. Driveway crossings traversing sidewalks with continuously planted furnishing zones must be designed to maintain the grade and clear width of the walkway they cross and must include returned curbs.
  - xi. The appearance of any walkway (ie. scoring pattern or special paving) must be maintained across any driveway or alley to indicate that, although a vehicle may cross, the area traversed by a vehicle remains part of the sidewalk.
- e. Parking Location
    - i. Required motor vehicle parking, excluding any required handicapped parking, may be provided off-site according to the following:
      - a). The off-site parking must be located within one thousand three hundred and twenty (1,320) feet in walking distance to the lot it will serve, measured from the nearest point of the off-site parking along block faces and walkways to the principal entrance of the use served;
      - b). Pedestrian access to off-site motor vehicle parking must be via a paved sidewalk or walkway.
      - c). A lease, recorded covenant, or other comparable legal instrument guaranteeing long term use of the site must be provided to the review board or building official and executed and filed with the Registry of Deeds.
    - ii. For real property located in more than one municipality, motor vehicle parking need not be located within the City of Somerville.
  - f. Parking Relief
    - i. Relief from the parking standards of Table 6.2 (b) requires a special permit.
      - a). In its discretion to approve or deny a special permit authorizing relief from the parking standards of Table 6.2 (b), the review board shall consider the following:
        - i). The supply and demand of on-street parking in the neighborhood, as determined through a parking study.
        - ii). Mobility management programs and services provided by the applicant to reduce the demand for parking.
        - iii). That parking provided in excess of any



# 6.0 COMMERCIAL DISTRICTS

Commercial Business (CB)

**TABLE 6.4 (b) Vehicular Parking**

\*See Transit Area Map to Identify Lots in a Transit Area

| Use Category<br>Specific Use                            | BICYCLE             |                    | MOTOR VEHICLE                     |                                       |
|---|---------------------|--------------------|-----------------------------------|---------------------------------------|
|   | Short-Term<br>(min) | Long-Term<br>(min) | Within a<br>Transit Area<br>(max) | Outside of a<br>Transit Area<br>(min) |
| <b>Arts &amp; Creative Enterprise</b>                   |                     |                    |                                   |                                       |
| Artisan Production                                      | 1 / 10,000 sf       | 1 / 3,000 sf       | 1 / 800 sf                        | 1 / 1,000 sf                          |
| Arts Exhibition   | 1 / 10,000 sf       | 1 / 3,000 sf       | 1 / 800 sf                        | 1 / 650 sf                            |
| Arts Sales & Services                                   | 1 / 10,000 sf       | 1 / 3,000 sf       | 1 / 200 sf                        | 1 / 1,000 sf                          |
| Design Services   | 1 / 10,000 sf       | 1 / 3,000 sf       | 1 / 800 sf                        | 1 / 1,000 sf                          |
| Shared Workspaces & Arts Education                      | 1 / 10,000 sf       | 1 / 3,000 sf       | 1 / 800 sf                        | 1 / 650 sf                            |
| <b>Civic &amp; Institutional</b>                        |                     |                    |                                   |                                       |
| Community Center  | 1 / 10,000 sf       | 4 / 10,000 sf      | 1 / 1,800 sf                      | 1 / 600 sf                            |
| Educational Facility                                    | 1.0 /<br>classroom  | 4.0 /<br>classroom | 1.5 /<br>classroom                | 3.0 /<br>classroom                    |
| Hospital  | 10 per<br>entrance  | 1 / 5,000 sf       | 1 / 200 sf                        | 1 / 1,000 sf                          |
| Library   | 1 / 3,000 sf        | 1 / 5,000 sf       | 1 / 800 sf                        | 1 / 500 sf                            |
| Minor Utility Facility                                  | n/a                 | n/a                | n/a                               | n/a                                   |
| Museum  | 1 / 2,000 sf        | 1 / 10,000 sf      | 1 / 800 sf                        | 1 / 500 sf                            |
| Private Non-Profit Club or Lodge                        | 1 / 2,000 sf        | 1 / 10,000 sf      | 1 / 200 sf                        | 1 / 1,000 sf                          |
| <b>Commercial Services</b>                              |                     |                    |                                   |                                       |
| Animal Services (as noted below)                        | 1 / 2,500 sf        | 1 / 10,000 sf      | –                                 | –                                     |
| Pet Grooming  | –                   | –                  | 1 / 500 sf                        | 1 / 400 sf                            |
| Veterinarian  | 1 / 2,000 sf        | 1 / 5,000 sf       | 1 / 500 sf                        | 1 / 500 sf                            |
| Assembly & Entertainment                                | 1 / 40 seats        | 1 / 10,000 sf      | 1 / 6 seats                       | 1 / 6 seats                           |
| Banking & Financial Services<br>(except as noted below) | 1 / 2,000 sf        | 1 / 10,000 sf      | 1 / 450 sf                        | 1 / 400 sf                            |
| Broadcast and/or Recording Studio                       | 1 / 2,500 sf        | 1 / 10,000 sf      | 1 / 800 sf                        | 1 / 600 sf                            |
| Building & Home Repair Services                         | 1 / 2,500 sf        | 1 / 10,000 sf      | 1 / 1,000 sf                      | 1 / 2,000 sf                          |
| Business Support Services                               | 1 / 2,500 sf        | 1 / 10,000 sf      | 1 / 900 sf                        | 1 / 600 sf                            |
| Caterer/Wholesale Food Production                       | 1 / 2,500 sf        | 1 / 10,000 sf      | 1 / 800 sf                        | 1 / 1,000 sf                          |
| Day Care Service  | 2                   | 1 / 10,000 sf      | 1 / 900 sf                        | 1 / 600 sf                            |
| Maintenance & Repair of Consumer Goods                  | 1 / 2,500 sf        | 1 / 10,000 sf      | 1 / 750 sf                        | 1 / 1,000 sf                          |
| Personal Services (except as noted below)               | 1 / 2,500 sf        | 1 / 10,000 sf      | 1 / 750 sf                        | 1 / 1,000 sf                          |
| Gym or Health Club                                      |                     |                    | 1 / 200 sf                        | 1 / 500 sf                            |

sf - Gross Leasable Square Footage

DU - Dwelling Unit

RU - Rooming Unit

# 6.0 COMMERCIAL DISTRICTS

Commercial Business (CB)

**TABLE 6.4 (b) Vehicular Parking (continued)**

\*See Transit Area Map to Identify Lots in a Transit Area

| Use Category<br>Specific Use               | BICYCLE             |   | MOTOR VEHICLE                     |                                       |
|--|---------------------|---|-----------------------------------|---------------------------------------|
|  | Short-Term<br>(min) | Long-Term<br>(min)                      | Within a<br>Transit Area<br>(max) | Outside of a<br>Transit Area<br>(min) |
| Funeral Home                               |                     |   |                                   |                                       |
| Health Care Provider                       | 1 / 2,000 sf        | 1 / 10,000 sf                           | 1 / 500 sf                        | 1 / 300 sf                            |
| Recreation Facility                        | 1 / 2,500 sf        | 1 / 10,000 sf                           |                                   |                                       |
| Vehicle Parking                            | n/a                 | 10 or 1 / 10<br>motor vehicle<br>spaces | n/a                               | n/a                                   |
| <b>Eating and Drinking</b>                 |                     |   |                                   |                                       |
| Bar/Restaurant/Tavern                      | 1 / 1,000 sf        | 1 / 5,000 sf                            | 1 / 300 sf                        | 1 / 500 sf                            |
| Bakery/Café/Coffee Shop                    | 1 / 1,000 sf        | 1 / 5,000 sf                            | 1 / 300 sf                        | 1 / 500 sf                            |
| Formula Eating & Drinking Establishment    | 1 / 1,000 sf        | 1 / 5,000 sf                            | 1 / 300 sf                        | 1 / 500 sf                            |
| <b>Lodging</b>                             |                     |   |                                   |                                       |
| Bed & Breakfast                            | 1 / 20 rooms        | 1 / 10 rooms                            | 1 / DU + 1 / 4<br>guest rooms     | 1 / DU + 1 / 4<br>guest rooms         |
| Hotel or Hostel                            | 1 / 20 rooms        | 1 / 10 rooms                            | 1 / 2 guest<br>rooms              | 1 / 2 guest<br>rooms                  |
| Short Term Rental                          | 1 / 20 rooms        | 1 / 10 rooms                            | n/a                               | n/a                                   |
| <b>Office</b>                              |                     |   |                                   |                                       |
| Co-Working                                 | 1 / 20,000 sf       | 1 / 3,000 sf                            | 1 / 1,200 sf                      | 1 / 800 sf                            |
| General Office                             | 1 / 20,000 sf       | 1 / 3,000 sf                            | 1 / 900 sf                        | 1 / 650 sf                            |
| Research and Development and/or Laboratory | 1 / 20,000 sf       | 1 / 5,000 sf                            | 1 / 1,000 sf                      | 1 / 1,000 sf                          |
| <b>Residential</b>                         |                     |   |                                   |                                       |
| Household Living                           | 0.1 / DU            | 1.0 / DU                                | 1.0 / DU                          | 1.0 / DU                              |
| Group Living<br>(except as follows)        | 0.05 / room         | 0.5 / room                              | –                                 | –                                     |
| Community or Group Residence               |                     |   |                                   |                                       |
| Dormitory, Fraternity or Sorority          | 0.1 / room          | 0.5 / room                              | .05 / bed                         | 1.0 / 4 beds                          |
| Homeless Shelter                           |                     |   | 4.0                               | 4.0                                   |
| Nursing Home/Assisted Living Facility      |                     |   | 1 / 6 beds                        | 1 / 6 beds                            |
| Single Room Occupancy Housing              |                     |   | 1 / 6 beds                        | 1 / 4 beds                            |

sf - Gross Leasable Square Footage

DU - Dwelling Unit

RU - Rooming Unit

# 6.0 COMMERCIAL DISTRICTS

Commercial Business (CB)

**TABLE 6.4 (b) Vehicular Parking (continued)**

\*See Transit Area Map to Identify Lots in a Transit Area

| Use Category<br>Specific Use       | BICYCLE             |                    | MOTOR VEHICLE                     |                                       |
|------------------------------------|---------------------|--------------------|-----------------------------------|---------------------------------------|
|                                    | Short-Term<br>(min) | Long-Term<br>(min) | Within a<br>Transit Area<br>(max) | Outside of a<br>Transit Area<br>(min) |
| <b>Retail Sales</b>                |                     |                    |                                   |                                       |
| Building/Home Supplies & Equipment | 1 / 2,500 sf        | 1 / 10,000 sf      | 1 / 1,000 sf                      | 1 / 1,000 sf                          |
| Consumer Goods (except as follows) | 1 / 2,500 sf        | 1 / 10,000 sf      | 1 / 1,500 sf                      | 1 / 750 sf                            |
| Packaged Liquor                    |                     |                    |                                   |                                       |
| Medical Marijuana                  |                     |                    |                                   |                                       |
| Pet Store                          |                     |                    |                                   |                                       |
| Formula Retail                     | 1 / 2,500 sf        | 1 / 10,000 sf      | 1 / 1,500 sf                      | 1 / 750 sf                            |
| Fresh Food Market or Grocery Store | 1 / 1,000 sf        | 1 / 10,000 sf      | 1 / 500 sf                        | 1 / 1,500 sf                          |
| Farm/Vendor Market                 | n/a                 | n/a                | n/a                               | 1 / 1,500 sf                          |

sf - Gross Leasable Square Footage

DU - Dwelling Unit

RU - Rooming Unit

# 6.0 COMMERCIAL DISTRICTS

## Commercial Business (CB)

maximum permitted does not result in the increase in impervious lot area.

### 15. Site Development

- a. General
  - i. Development is subject the provisions of Article 10: Site Development Standards of this Ordinance. Where the provisions of this section conflict with those of Article 10, the provisions of Article 10 apply.
- b. Signs
  - i. A sign, individual numerals or letters, or a nonelectrical nameplate identifying the property address is required for all real property as follows:
    - a). Each ground story non-residential use must identify the street address either on the principal entrance door or above or beside the principal entrance of the use.
    - b). All residential building types must identify the street address either on the principal entrance door, above or beside the principal entrance, or on a mailbox.
  - ii. Address signs must be made easily visible through the use of colors or materials that contrast with the background material they are attached to and must be conspicuously located to provide visibility from the thoroughfare that the building faces.
  - iii. Address signs must be twelve (12) inches in height or less and may include the name of the occupant.

# 6.0 COMMERCIAL DISTRICTS

Commercial Business (CB)

# 6.0 COMMERCIAL DISTRICTS

Commercial Business (CB)