

### 3 RESIDENTIAL DISTRICTS

**3.1 NEIGHBORHOOD RESIDENCE (NR) .....9**

Character Description	9
Intent	10
Purpose	10
Applicability	10
Development Review	10
Building Types	10
Building Components	27
Private Frontage	31
Building Design Standards	34
Architectural Design Guidelines	34
Use Provisions	35
Vehicular Parking	37
Site Development	38

**3.2 URBAN RESIDENCE (UR) .....39**

Character Description	39
Intent	40
Purpose	40
Applicability	40
Development Review	40
Building Types	40
Building Components	65
Private Frontage	69
Building Design Standards	74
Architectural Design Guidelines	74
Use Provisions	75
Vehicular Parking	77
Site Development	78

**DISCUSSION DRAFT**



## 3.1 NEIGHBORHOOD RESIDENCE (NR)

### 1. Character Description

The Neighborhood Residence district is characterized by a variety of small and moderate floor plate, one- and two-unit buildings with minimal front and side setbacks to help prioritize back yard space. The district is almost entirely residential, with occasional neighborhood stores, schools, places of worship, and arts related uses on advantageous sites.



# 3. RESIDENTIAL DISTRICTS

## Neighborhood Residence (NR)

### 2. Intent

- a. To implement the Neighborhood Residential context from the Future Land Context Map of SomerVision.
- b. To conserve already established areas of detached and semi-detached residential buildings.

### 3. Purpose

- a. To permit the development of one- and two-unit detached and semi-detached residential buildings on individual lots.
- b. To permit contextual modifications to existing detached and semi-detached residential buildings.
- c. To permit the adaptive reuse of certain existing nonconforming buildings for arts & creative enterprise and retail uses compatible with residential areas.

### 4. Applicability

- a. The section is applicable to all real property within the Neighborhood Residence district as shown on the maps of the Official Zoning Atlas of the City of Somerville.

### 5. Development Review

- a. Development on any lot requires the submittal of a development review application to the Building Official.
- b. A pre-submittal meeting is recommended for all development.
- c. Proposed development may or may not necessitate the need for a Special Permit or a Variance based on the nature of the proposal. In such cases, additional development review is required in accordance with Article 15: Administration.
  - i. The Zoning Board of Appeals is the decision making authority for all development that requires

a Special Permit in the Neighborhood Residence district.

- d. Upon completion of the required development review, a Certificate of Zoning Compliance shall be issued by the Building Official to certify compliance with the provisions and procedures of this Ordinance.

### 6. Building Types

- a. One (1) principal building type may be built on each lot.
- b. The following principal building types are permitted in the Neighborhood Residence district:
  - i. Cottage
  - ii. Detached House
  - iii. Semi-Detached House
  - iv. Duplex
- c. Accessory structures are regulated according to Article 10: Development Standards of this Ordinance.

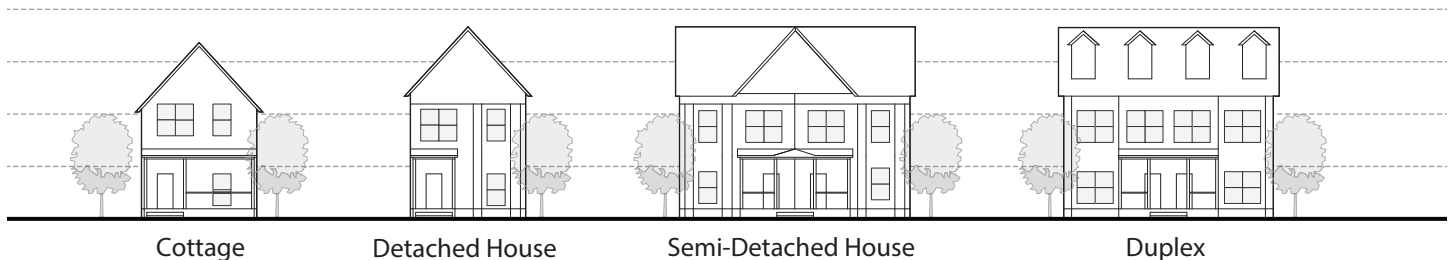

### 3. RESIDENTIAL DISTRICTS

Neighborhood Residence (NR)

#### 7. Cottage

A small floor plate, detached, residential building type with one dwelling unit. The cottage is the smallest type of detached housing in Somerville. Two variants exist, one with a half-story under pitched roof and another with a full height second story and a shallow pitched roof or a flat roof.

The following images are examples from Somerville of the cottage building type and are intended only for illustrative purposes.



# 3. RESIDENTIAL DISTRICTS

Neighborhood Residence (NR)

## 7. Cottage (continued)

a. Lot Standards

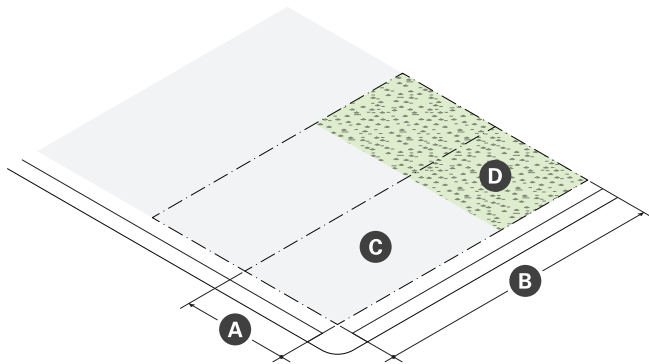

Lot Dimensions	
<b>A</b> Width (min)	--
No Driveway Access	32 ft
Side or Rear Driveway Access	32 ft
Front Driveway Access	35 ft
<b>B</b> Depth (min)	70 ft

Lot Development	
<b>C</b> Lot Coverage (max)	65%
<b>D</b> Green Factor (min)	0.35

b. Building Placement

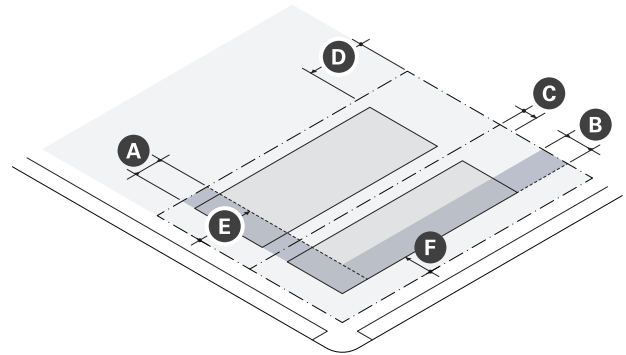

Building Setbacks		
<b>A</b> Primary Front Setback (min/max)	10 ft	20 ft
<b>B</b> Secondary Front Setback (min/max)	10 ft	20 ft
<b>C</b> Side Setback (min)	5 ft	
<b>D</b> Rear Setback (min)	20 ft	

Parking Setbacks	
<b>E</b> Primary Front Setback (min)	20 ft
<b>F</b> Secondary Front Setback (min)	10 ft

# 3. RESIDENTIAL DISTRICTS

Neighborhood Residence (NR)

## 7. Cottage (continued)

c. Massing & Height

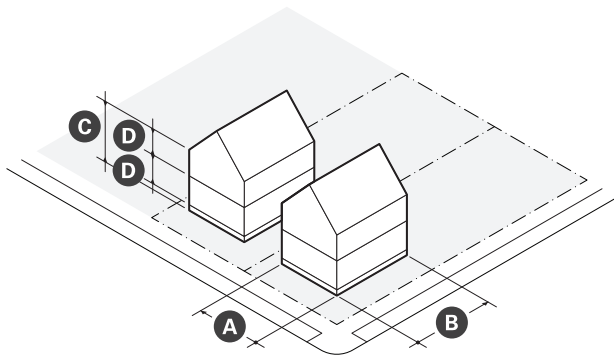

d. Uses & Features

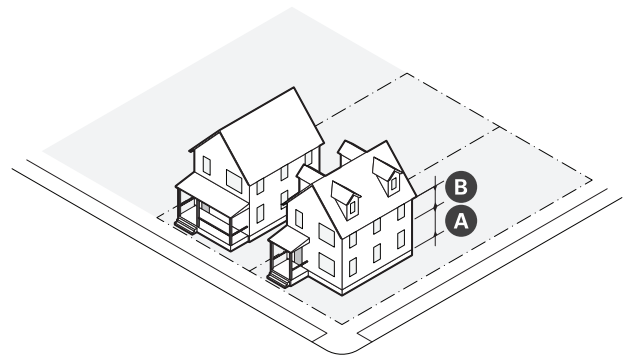

Main Body	
Facade Build Out (min)	60%
<b>A</b> Width (min/max)	22 ft 26 ft
<b>B</b> Depth (min/max)	24 ft 32 ft
<b>C</b> Building Height (max)	2 stories
<b>D</b> Story Height (min/max)	10 ft 12 ft
Ground Floor Elevation (min)	2 ft
Roof Type	Flat, Gable, Mansard

Facade Composition	
<b>A</b> Ground Story Fenestration (min/max)	20% 50%
<b>B</b> Upper Story Fenestration (min/max)	20% 50%

Use & Occupancy	
Dwelling Units (max)	1
Outdoor Amenity Space (min)	1/ DU

### 3. RESIDENTIAL DISTRICTS

Neighborhood Residence (NR)

- e. Housing
  - i. There is no affordable housing requirement for a cottage.

**FIGURE 3.1 (a) Dwelling Unit Orientation**

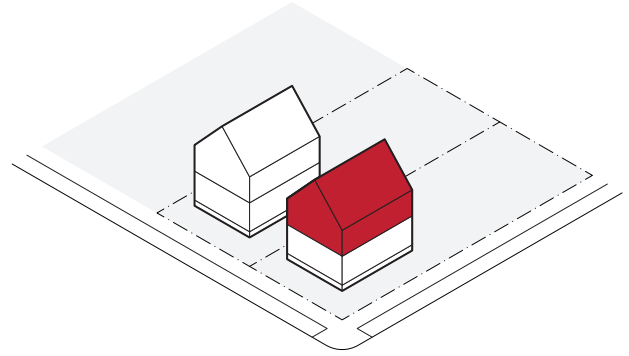



### 3. RESIDENTIAL DISTRICTS

Neighborhood Residence (NR)

#### 8. Detached House

A moderate floor plate, detached, residential building type with one dwelling unit or two vertically stacked dwelling units, where each unit typically has its own front door. The house is the most prevalent building type in Somerville. When the second floor is split between the two dwelling units, this type is referred to as a "Philly Style".

The following images are examples from Somerville of the house building type and are intended only for illustrative purposes.



# 3. RESIDENTIAL DISTRICTS

Neighborhood Residence (NR)

## 8. Detached House (continued)

a. Lot Standards

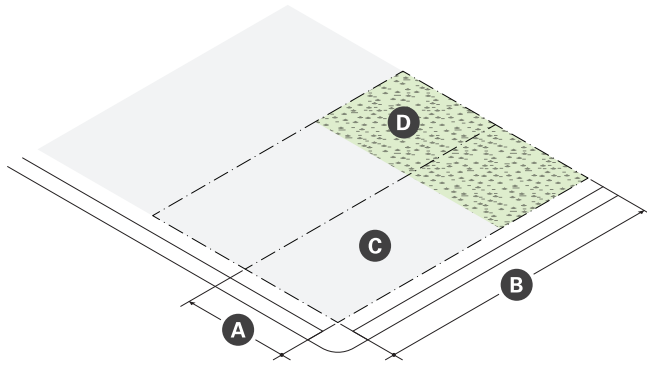

Lot Dimensions	
<b>A</b> Width (min)	--
No Driveway Access	32 ft
Side or Rear Driveway Access	32 ft
Front Driveway Access	35 ft
<b>B</b> Depth (min)	80 ft

Lot Development	
<b>C</b> Lot Coverage (max)	65%
<b>D</b> Green Factor (min)	0.35

b. Building Placement

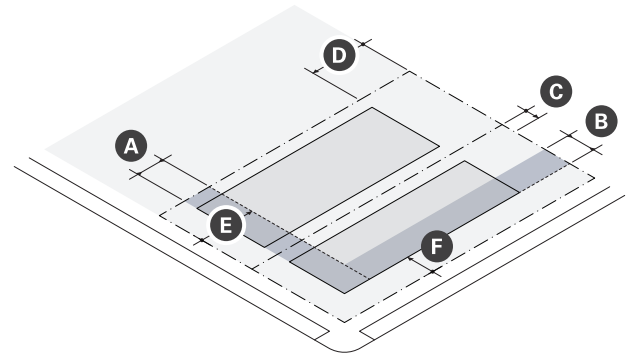

Building Setbacks		
<b>A</b> Primary Front Setback (min/max)	10 ft	20 ft
<b>B</b> Secondary Front Setback (min/max)	10 ft	20 ft
<b>C</b> Side Setback (min)	5 ft	
<b>D</b> Rear Setback (min)	20 ft	

Parking Setbacks	
<b>E</b> Primary Front Setback (min)	20 ft
<b>F</b> Secondary Front Setback (min)	10 ft

# 3. RESIDENTIAL DISTRICTS

Neighborhood Residence (NR)

## 8. Detached House (continued)

c. Massing & Height

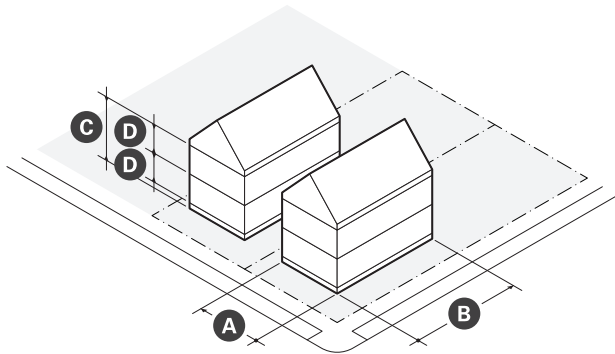

d. Uses & Features



### Main Body

Facade Build Out (min)	50%
<b>A</b> Width (min/max)	22 ft 28 ft
<b>B</b> Depth (min/max)	28 ft 48 ft
<b>C</b> Building Height (max)	2.5
<b>D</b> Story Height (min/max)	10 ft 12 ft
Ground Floor Elevation (min)	2 ft
Roof Type	Flat, Gable, Mansard

### Facade Composition

<b>A</b> Ground Story Fenestration (min/max)	20%	50%
<b>B</b> Upper Story Fenestration (min/max)	20%	50%

### Use & Occupancy

Dwelling Units (max)	2
Outdoor Amenity Space (min)	1/ DU

### 3. RESIDENTIAL DISTRICTS

#### Neighborhood Residence (NR)

- e. Housing
  - i. There is no affordable housing requirement for a detached house.
  - ii. The individual floors of a house may be built or converted internally so that dwelling units are stacked one over the other as shown in Figure 3.1.8.
  - iii. Houses are not permitted to have dwelling units that are side-by-side or front-to-back in orientation.

**FIGURE 3.1 (b) Dwelling Unit Orientation**

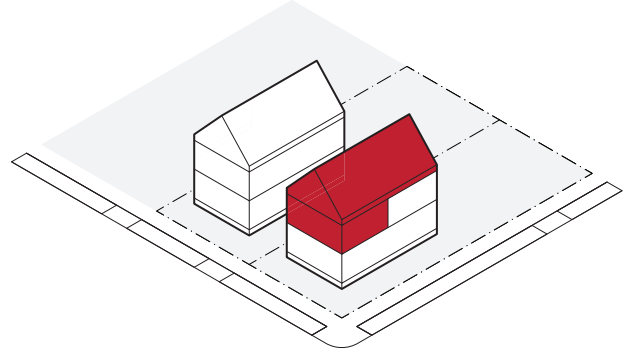

### 3. RESIDENTIAL DISTRICTS

Neighborhood Residence (NR)

#### 9. Semi-Detached House

A moderate floor plate, semi-detached, residential building type with one dwelling unit or two vertically stacked dwelling units. A semi-detached house must be attached on one side to another semi-detached house by a party wall.

The following images are examples from Somerville of the semi-detached house building type and are intended only for illustrative purposes.



# 3. RESIDENTIAL DISTRICTS

Neighborhood Residence (NR)

## 9. Semi-Detached House (continued)

a. Lot Standards

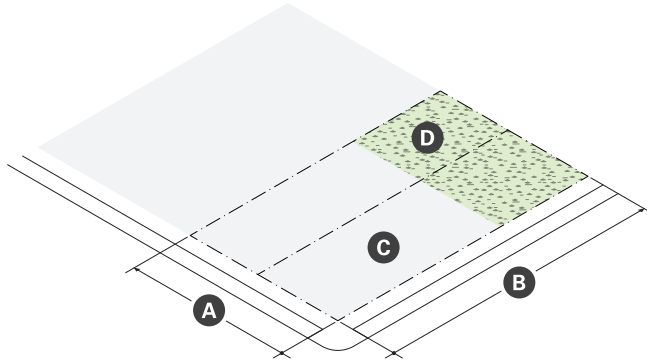

b. Building Placement

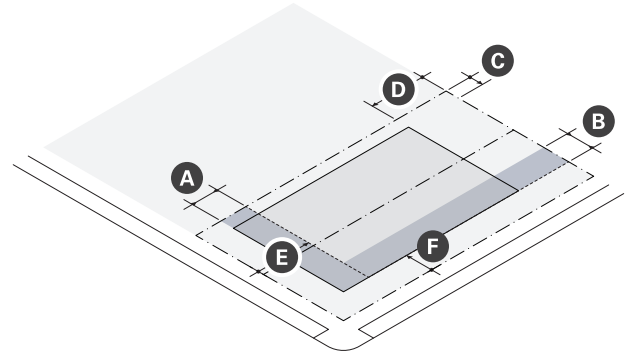

Lot Dimensions	
<b>A</b> Width (min)	--
No Driveway Access	27 ft
Side or Rear Driveway Access	27 ft
Front Driveway Access	30 ft
<b>B</b> Depth (min)	80 ft

Lot Development	
<b>C</b> Lot Coverage (max)	65%
<b>D</b> Green Factor (min)	0.35

Building Setbacks		
<b>A</b> Primary Front Setback	10 ft	20 ft
<b>B</b> Secondary Front Setback	10 ft	20 ft
<b>C</b> Side Setback (min)	--	
Party Lot Line	0 ft	
Side Lot Line	5 ft	
<b>D</b> Rear Setback (min)	20 ft	

Parking Setbacks	
<b>E</b> Primary Front Setback (min)	20 ft
<b>F</b> Secondary Front Setback (min)	10 ft

## 9. Semi-Detached House (continued)

c. Massing & Height

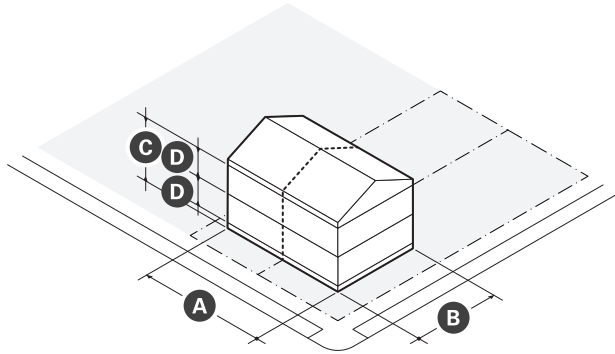

Main Body	
Facade Build Out (min)	50%
<b>A</b> Width (min/max)	22 ft 28 ft
<b>B</b> Depth (min/max)	28 ft 48 ft
<b>C</b> Building Height (max)	2.5
<b>D</b> Story Height (min/max)	10 ft 12 ft
Ground Floor Elevation (min)	2 ft
Roof Type	Flat, Gable, Mansard

d. Uses & Features

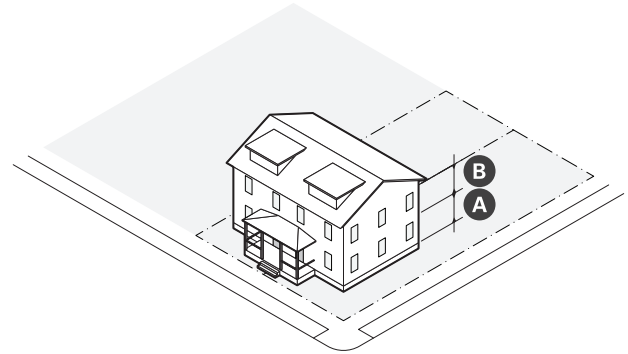

Facade Composition	
<b>A</b> Ground Story Fenestration (min/max)	20% 50%
<b>B</b> Upper Story Fenestration (min/max)	20% 50%

Use & Occupancy	
Dwelling Units (max)	2
Outdoor Amenity Space (min)	1/ DU

### 3. RESIDENTIAL DISTRICTS

#### Neighborhood Residence (NR)

- e. Housing
  - i. There is no affordable housing requirement for a semi-detached house.
  - ii. The individual floors of a semi-detached house may only be built or converted internally so that dwelling units are stacked one over the other as shown in Figure 3.1.9.
  - iii. Semi-detached houses are not permitted to have dwelling units that are attached side-by-side or front-to-back in orientation.

**FIGURE 3.1 (c) Dwelling Unit Orientation**

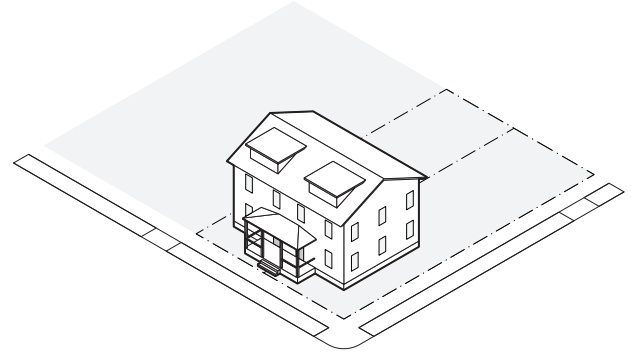



### 3. RESIDENTIAL DISTRICTS

Neighborhood Residence (NR)

#### 10. Duplex

A moderate floor plate, detached, residential building type with two side-by-side dwelling units. When occupying a corner lot, the duplex may have dwelling units attached back to side so that one dwelling unit is oriented toward each frontage.

The following images are primarily examples from Somerville of the duplex building type and are intended only for illustrative purposes.



# 3. RESIDENTIAL DISTRICTS

Neighborhood Residence (NR)

## 10. Duplex (continued)

a. Lot Standards

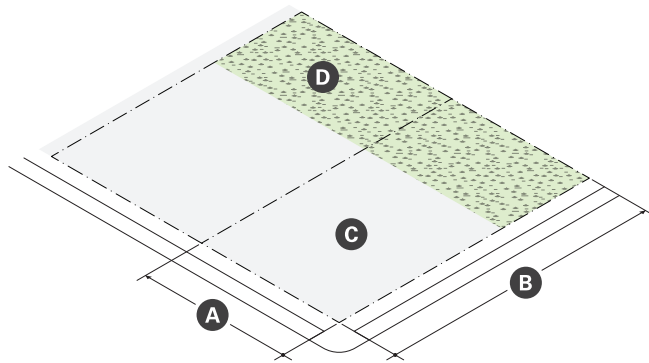

Lot Dimensions	
<b>A</b> Width (min)	--
No Driveway Access	50 ft
Side or Rear Driveway Access	50 ft
Front Driveway Access	53 ft
<b>B</b> Depth (min)	70 ft

Lot Development	
<b>C</b> Lot Coverage (max)	65%
<b>D</b> Green Factor (min)	0.35

b. Building Placement

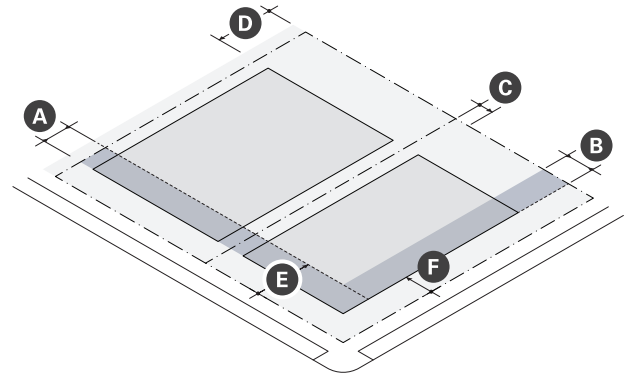

Building Setbacks		
<b>A</b> Primary Front Setback (min/max)	10 ft	20 ft
<b>B</b> Secondary Front Setback (min/max)	10 ft	20 ft
<b>C</b> Side Setback (min)	5 ft	
<b>D</b> Rear Setback (min)	20 ft	

Parking Setbacks	
<b>E</b> Primary Front Setback (min)	20 ft
<b>F</b> Secondary Front Setback (min)	10 ft

# 3. RESIDENTIAL DISTRICTS

Neighborhood Residence (NR)

## 10. Duplex (continued)

c. Massing & Height

d. Uses & Features

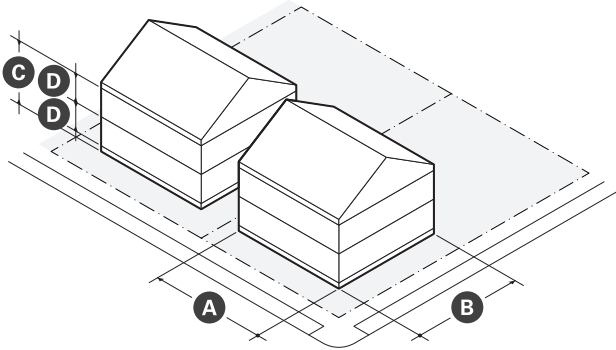

Main Body	
Facade Build Out (min)	50%
<b>A</b> Width (min/max)	40 ft 56 ft
<b>B</b> Depth (min/max)	30 ft 52 ft
<b>C</b> Building Height (max)	2.5 stories
<b>D</b> Story Height (min/max)	10 ft 12 ft
Ground Floor Elevation (min)	2 ft
Roof Type	Flat, Gable, Mansard

Facade Composition	
<b>A</b> Ground Story Fenestration (min/max)	20% 50%
<b>B</b> Upper Story Fenestration (min/max)	20% 50%

Use & Occupancy	
Dwelling Units (max)	2
Outdoor Amenity Space (min)	1/ DU

### 3. RESIDENTIAL DISTRICTS

#### Neighborhood Residence (NR)

- e. Housing
  - i. There is no affordable housing requirement for a duplex.
  - ii. Duplexes must be designed so that the dwelling units are side-by-side and both oriented toward the front lot line, except that on a corner lot a duplex may have dwelling units attached back to side, with one dwelling unit oriented toward each front lot line. See Figure 3.1.10.
  - iii. Duplexes are not permitted to have dwelling units that are stacked one over the other or attached front to back in orientation.

**FIGURE 3.1 (d) Dwelling Unit Orientation**

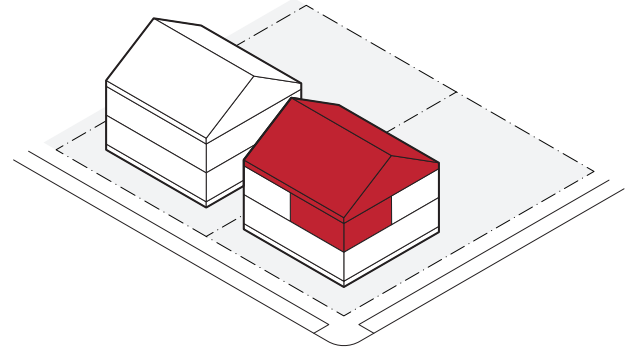

# 3. RESIDENTIAL DISTRICTS

## Neighborhood Residence (NR)

### 11. Building Components

- a. Building components are accessory features that increase the habitable square footage or enhance the usefulness of a principal building.
- b. The following building components are permitted for all building types in the Neighborhood Residence district:
  - i. Entry Canopy
  - ii. Bay
  - iii. Dormer Window
  - iv. Cross Gable
  - v. Side Wing
  - vi. Rear Addition
  - vii. Roof Deck
- c. Features such as decks, stoops, porticos, and porches attached to the side or rear of the main body of a principal building are permitted provided that they do not violate any side or rear setback.

### D. Entry Canopy

- i. An entry canopy is a wall-mounted structure that provides shade and weather protection over the entrance of a building.

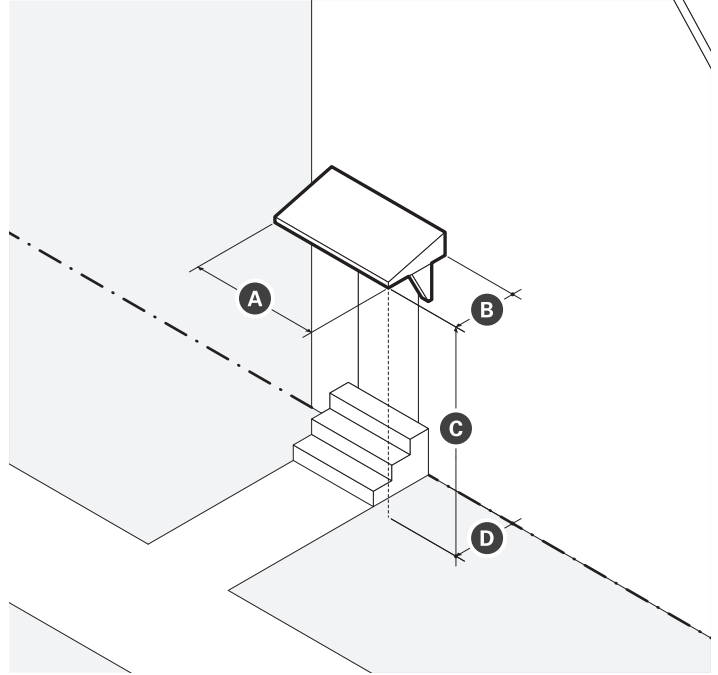

Dimensions	
<b>A</b> Width (min)	See §3.1.11.D.ii.b
<b>B</b> Depth (max)	3 ft
<b>C</b> Clearance (min)	8 ft clear
<b>D</b> Permitted Setback Encroachment (max)	100%

- ii. Standards
  - a). Entry canopies must be visually supported by brackets, cables, or rods.
  - b). The width of an entry canopy must be equal to or greater than the width of the doorway surround, trim, or exterior casing it is mounted above.

### 3. RESIDENTIAL DISTRICTS

Neighborhood Residence (NR)

#### E. Bay

- i. A bay is a window assembly extending from the main body of a building to permit increased light, provide multi-direction views, and articulate a building’s facade.

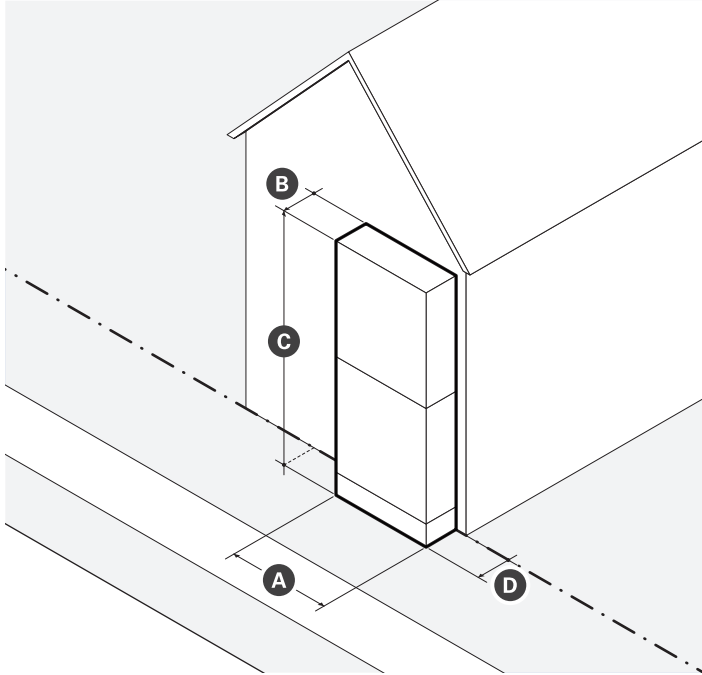

Dimensions	
<b>A</b> Width (min)	50% of facade or elevation
<b>B</b> Depth (max)	3 ft
<b>C</b> Height (max)	Height of Building
Fenestration (min)	60%
<b>D</b> Permitted Setback Encroachment (max)	3 ft

- ii. Standards
  - a). Bays must have a foundation extending all the way to ground level or be visually supported by brackets or other architectural supports.
  - b). Bays projecting over the sidewalk of a public thoroughfare must have two (2) stories of clearance and compliance with all City Ordinances.

#### F. Dormer Window

- i. A dormer window is a single window or set of windows that projects vertically from a sloped roof, designed to provide light into and expand the habitable space of a half-story.

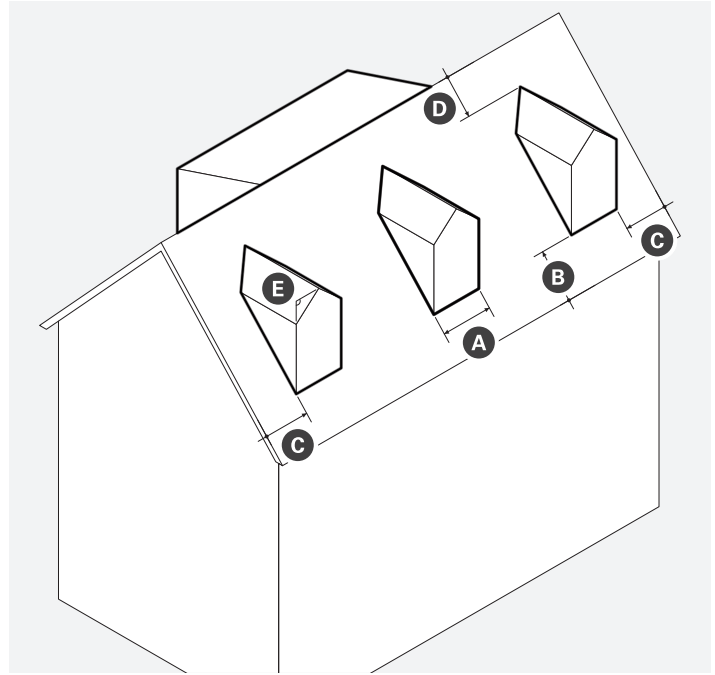

Dimensions	
<b>A</b> Width (max)	24 feet or 50% of the eave length of the main roof (whichever is shorter)
<b>B</b> Front & Rear Wall Setback (min)	3 ft 6 in
<b>C</b> Side Wall Setback (min)	1 ft 6 in
<b>D</b> Ridge Line Setback (min)	1 ft
<b>E</b> Roof Slope (min)	4:12 (18.43°)
Fenestration (min)	70%

- ii. Standards
  - a). Setbacks are strictly enforced regardless of permitted dormer width.
  - b). The maximum permitted width of a dormer applies to single, multiple, or attached combinations of dormers on each side of a roof.

### 3. RESIDENTIAL DISTRICTS

Neighborhood Residence (NR)

#### G. Cross Gable

- i. A cross gable is a sloped roof that projects perpendicularly from the main roof of a building to significantly increase the habitable space of a half-story.

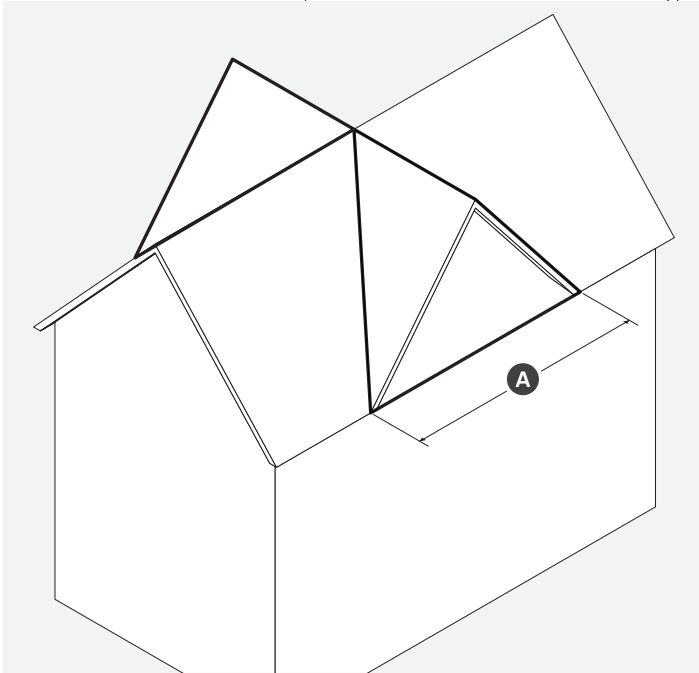

Dimensions	
<b>A</b> Width (max)	50% of the eave length of the main roof

- ii. Standards
  - a). The rakes of the cross gable roof must be structurally integrated into the eave and ridge of the main roof.

#### H. Side Wing

- i. A side wing is a multi-story extension from one or more side walls of the main body of a building.

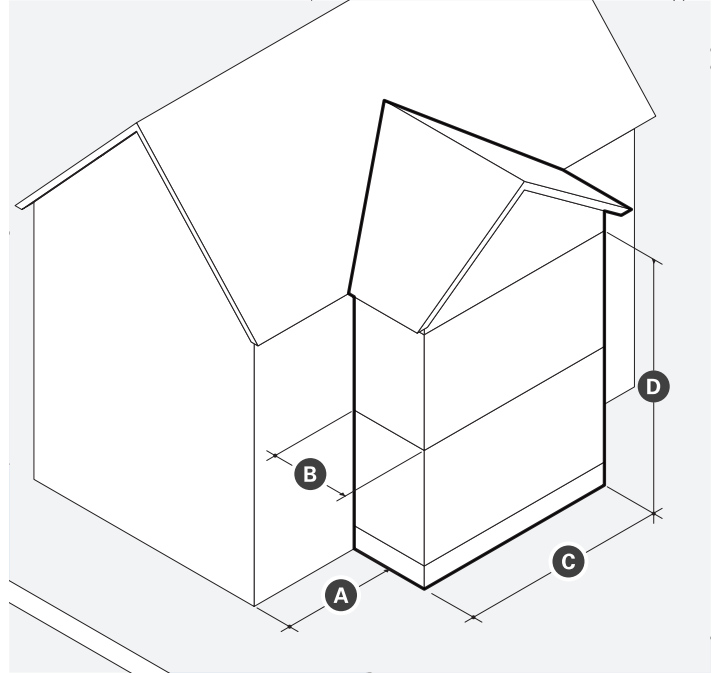

Dimensions	
<b>A</b> Setback from Facade (min)	5 ft
<b>B</b> Floor Plate (max)	4 ft
<b>C</b> Width (max)	--
One (1) Story	1/2 of Main Body Width
Two (2) or More Stories	1/3 of Main Body Width
<b>D</b> Height (max)	Same as Principal Building

- ii. Standards
  - a). Side wings must include a similarly style roof as the Principal Building.

# 3. RESIDENTIAL DISTRICTS

Neighborhood Residence (NR)

## I. Rear Addition

- i. A rear addition is an extension from the rear wall of the main body of a building.

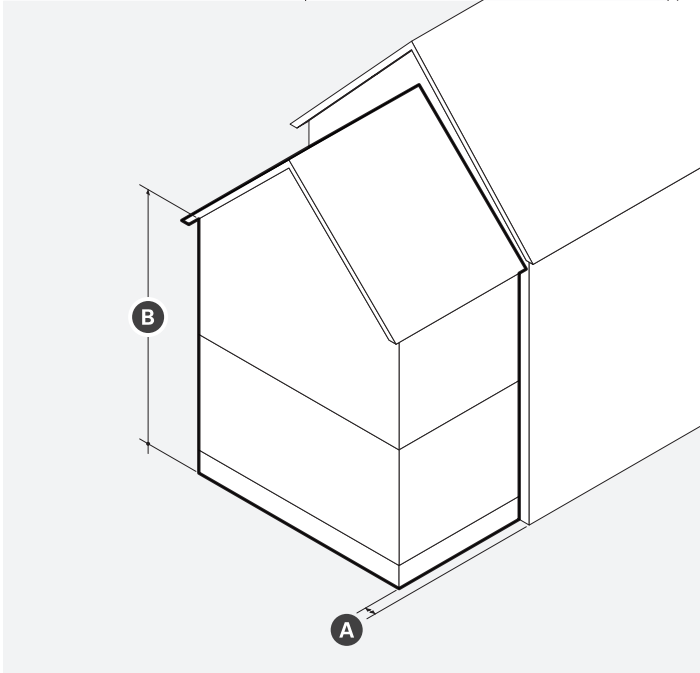

Dimensions	
<b>A</b> Setback from Exterior Side Walls (min)	1 ft
Floor Plate (max)	50% of the Floor Plate of the Principal Building
<b>B</b> Height (max)	Two (2) Stories

- ii. Standards
  - a). The slope of any pitched roof of a rear addition must be equal to or less than slope of the roof of the main body of the building and no less than nine and one-half degrees (9.5°; 2:12).

## J. Roof Deck

- i. A roof deck is a roofless, raised platform on the roof of a building, side wing, or rear addition that provides outdoor amenity space.

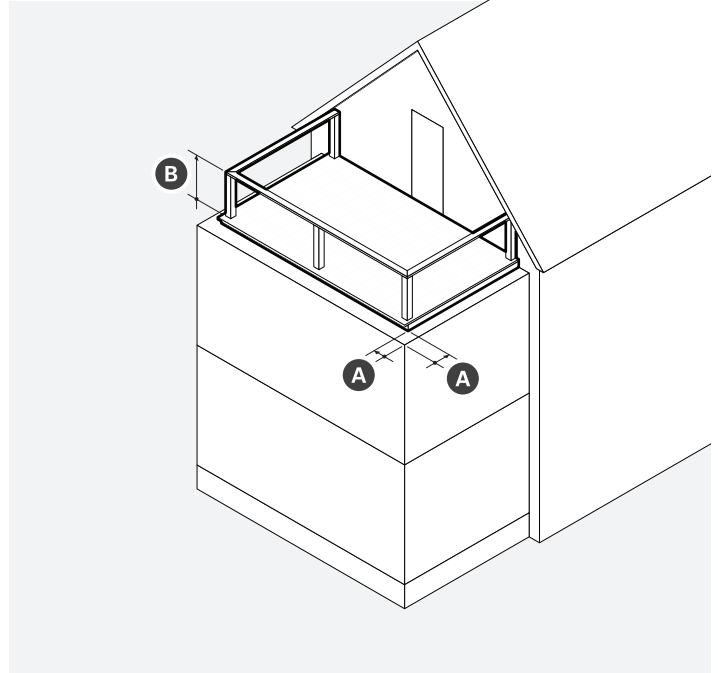

Dimensions	
<b>A</b> Setback from Facade (min)	5 ft
<b>B</b> Railing Height (max)	4 ft

- ii. Standards
  - a). Roof decks are only permitted on flat roofs.
  - b). The flooring of a roof deck must be no more than two feet above the roof supporting the deck.
  - c). Roof decks located within five (5) feet of a side rear lot line abutting the NR district must provide sight obscuring visual screening so that it is at least fifty percent (50%) opaque.
  - d). Roof deck access structures, such as stairwell penthouses, may not exceed 10 ft. in height and may only serve to enclose the access stairs and minimum landing required by Building Code.



# 3. RESIDENTIAL DISTRICTS

Neighborhood Residence (NR)

## 12. Private Frontage

- a. Private frontage must be designed as a building frontage type.
- b. Building frontage types facilitate access to principal entrances and serve as the interface and transition between the private realm (building interiors) and the public realm (sidewalks and civic spaces).
- c. The following building frontage types are permitted for all building types in the Neighborhood Residence (NR) district:
  - i. Stoop
  - ii. Portico
  - iii. Projecting Porch
  - iv. Engaged Porch
  - v. Dooryard
- d. Building frontage types may be combined as specified for each type and multiple frontage types may exist for buildings that have more than one principal entrance.

## E. Stoop

- i. A stoop is a frontage type featuring a set of stairs with a landing leading to the entrance of a building.

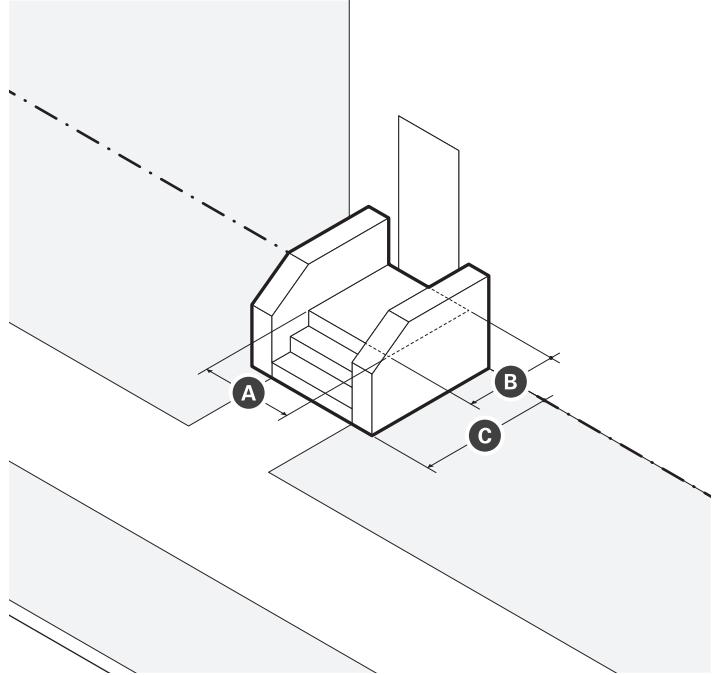

Dimensions	
<b>A</b> Landing Width (min)	4 ft
<b>B</b> Landing Depth (min)	4 ft
<b>C</b> Permitted Front Setback Encroachment (max)	100%

- ii. Standards
  - a). Paving, excluding driveways, must match the abutting sidewalk unless paved with pervious, porous, or permeable materials.
  - b). Stairs may be recessed into the building facade when the building is setback four (4) feet or less.
  - c). Stairs are not permitted to encroach onto any abutting sidewalk.
  - d). Stairs may be built perpendicular or parallel to the building facade, but must lead directly to ground level or an abutting sidewalk.

### 3. RESIDENTIAL DISTRICTS

Neighborhood Residence (NR)

#### F. Portico

- i. A portico is a frontage type featuring a set of stairs with a landing leading to the entrance of a building and a roof supported by columns, piers, or posts.

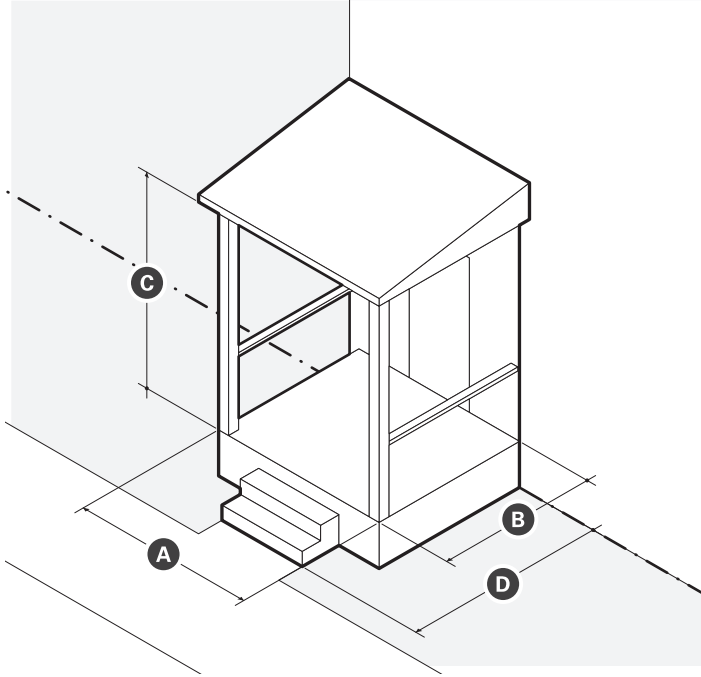

Dimensions	
<b>A</b> Landing Width (min)	4 ft
<b>B</b> Landing Depth (max)	4 ft
<b>C</b> Ceiling Height (max)	8 ft
<b>D</b> Permitted Front Setback Encroachment (max)	100%

- ii. Standards
  - a). Paving, excluding driveways, must match the abutting sidewalk unless paved with permeable paving.
  - b). Stairs are not permitted to encroach onto any abutting sidewalk.
  - c). Stairs may be built perpendicular or parallel to the building facade, but must lead directly to ground level or an abutting sidewalk.

#### G. Projecting Porch

- i. A projecting porch is a frontage type featuring a set of stairs with a landing leading to the entrance of a building and a roof supported by columns, piers, or posts.

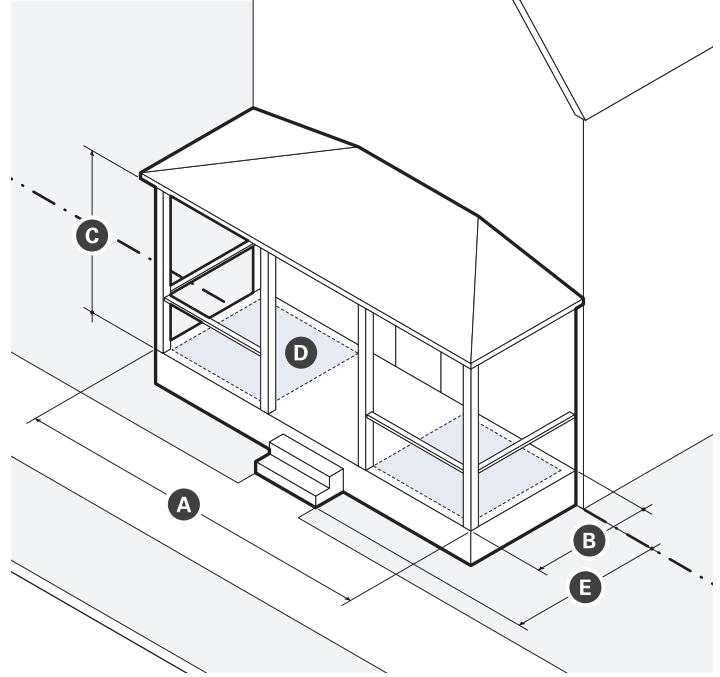

Dimensions	
<b>A</b> Width (min)	10' or 50% of facade width, whichever is greater
<b>B</b> Depth (min)	6 ft
<b>C</b> Ceiling Height (min)	8 ft
<b>D</b> Furniture Area, Clear (min)	6 ft x 6 ft
<b>E</b> Permitted Front Setback Encroachment (max)	10 ft

- ii. Standards
  - a). Paving, excluding driveways, must match the abutting sidewalk unless paved with permeable paving.
  - b). Stairs are not permitted to encroach onto any abutting sidewalk.
  - c). Porch railings must permit visual supervision of the public realm through the posts and rails.
  - d). A porch may be screened provided the percentage of window area to wall area is seventy percent (70%) or greater. Permanent enclosure of a porch to create year-round living space is not permitted.

## H. Engaged Porch

- i. An engaged porch is a frontage type featuring a porch attached to the building at two sides, one to the facade and the other to a mud room or entry foyer encroaching the front setback.

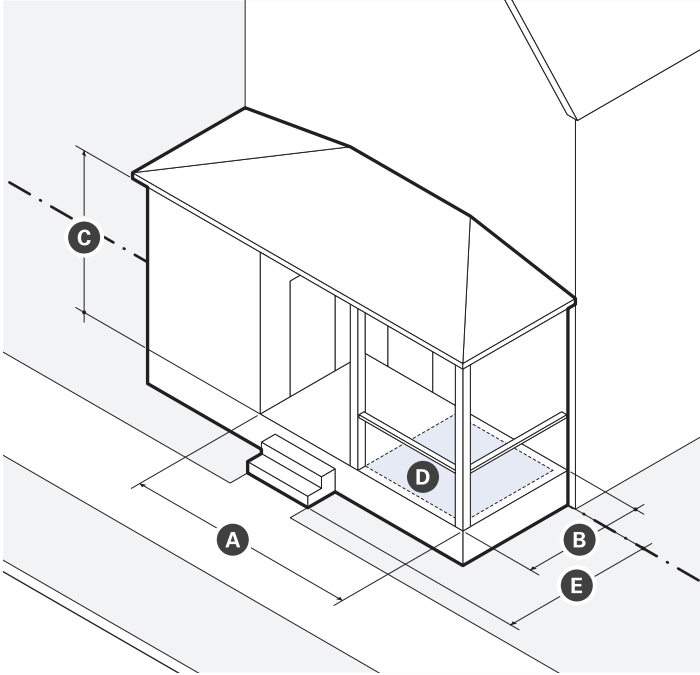

Dimensions	
<b>A</b> Width (min)	10' or 50% of facade width, whichever is greater
<b>B</b> Depth (min)	6 ft
<b>C</b> Ceiling Height (min)	8 ft
<b>D</b> Furniture Area, Clear (min)	6 ft x 6 ft
<b>E</b> Permitted Front Setback Encroachment (max)	10 ft

- ii. Standards
  - a). Paving, excluding driveways, must match the abutting sidewalk unless paved with permeable paving.
  - b). Stairs are not permitted to encroach onto any abutting sidewalk.
  - c). Porch railings must permit visual supervision of the public realm through the posts and rails.
  - d). A porch may be screened provided the percentage of window area to wall area is seventy percent (70%) or greater. Permanent enclosure of a porch to create year-round living space is not permitted.

## I. Dooryard

- i. A dooryard is a frontage type featuring fenced or elevated gardens or patios that buffer dwellings from an adjacent sidewalk.

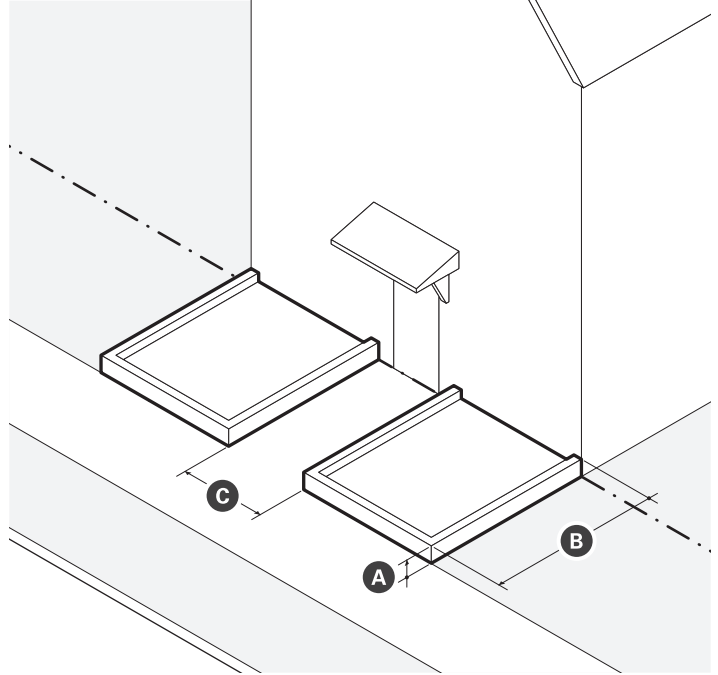

Dimensions	
Landscaped Area (min)	4 ft
<b>A</b> Elevation above Sidewalk (min)	18 in
<b>B</b> Depth (min)	100% of setback
<b>C</b> Path of Travel (min)	3 ft

- ii. Standards
  - a). Dooryards are an appropriate frontage type for a zero-step, accessible entrance, but may include steps leading to the entrance of the building.
  - b). Paving, excluding driveways, must match the abutting sidewalk unless paved with permeable paving.
  - c). A curb or retaining wall that is no taller than structurally necessary may be built around the planter, garden, terrace, or otherwise landscaped area.
  - d). Circulation between adjacent dooryards is prohibited.

### 3. RESIDENTIAL DISTRICTS

Neighborhood Residence (NR)

#### 13. Building Design Standards

- a. Contextual Front Setbacks
  - i. Notwithstanding the front setbacks identified for each building type, new construction must have a contextual front setback as follows:
    - a). If the subject lot is an interior lot or key lot, the minimum and maximum front setbacks are equal to the actual distances that principal structures are setback from the front lot line on the two abutting lots of the same block face. See Figure 3.1.13.
    - b). If the subject lot is a corner lot, the minimum front setback is equal to the actual distance that the principal structure is setback from the front lot line on the abutting lot that is oriented toward the same thoroughfare.
    - c). If the lot on either side of the subject lot is vacant, the minimum and maximum front setback identified for each building type governs.
  - ii. The contextual front setback provision does not exempt any building from complying with the maximum front setback required for each building type.

#### 14. Architectural Design Guidelines

- a. Privacy
  - i. Ground story dwelling units should be elevated above the grade of any adjacent sidewalk so that the window sills of dwelling unit are at or above the eye-level of passing pedestrians. This elevation change maintains privacy for occupants while also encouraging open blinds or curtains to allow natural daylight into the unit.
  - ii. Fenestration patterns and window configurations that break the direct line of sight between neighboring properties should be utilized to every extent possible. Translucent glass on the bottom half of windows or strategically placed landscape elements should be utilized if it is not practical to off-set windows in ways that minimize privacy impacts.
  - iii. Outdoor amenity spaces that are elevated such as roof decks, fully projecting balconies, and upper story rear porches should include screening walls or devices at the sides to provide privacy, security, and limit views of abutting properties from elevated vantage points.

FIGURE 3.1 (e) Contextual Front Setback

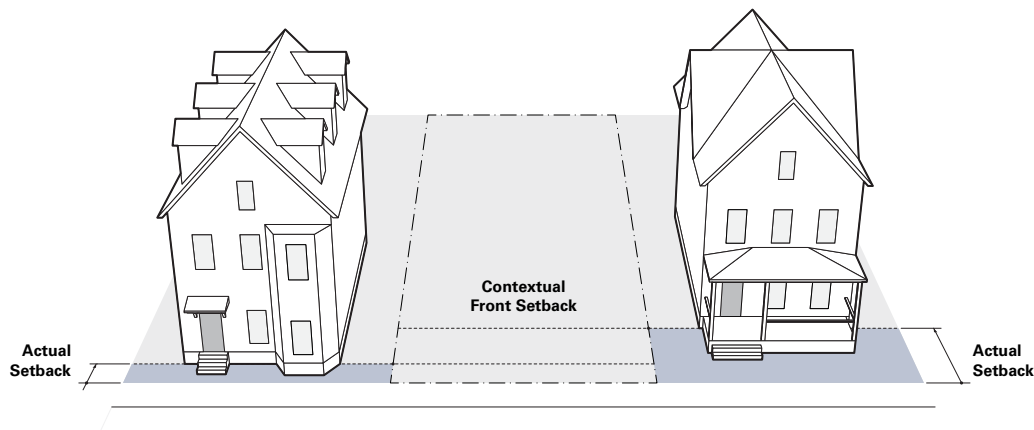

# 3. RESIDENTIAL DISTRICTS

Neighborhood Residence (NR)

## 15. Use Provisions

- a. Permitted Uses
  - i. The use of real property is subject to the provisions of Article 9: Use Provisions of this Ordinance. Where the provisions of this section conflict with those of Article 9, the provisions of Article 9 apply.
  - ii. Uses are permitted as specified on Table 3.1 (a).
  - iii. Use categories not expressly authorized are prohibited.
  - iv. All uses must comply with any use-specific standards applicable for each use in §9.2 Use Definitions & Limitations.
  - v. Uses permitted by Special Permit require additional development review in accordance with §15.2.1 Special Permits.
- b. Adaptive Re-Use of Specific Buildings
  - i. The use of any principal structure constructed before the effective date of this Ordinance for a non-residential use that is considered nonconforming in the Neighborhood Residence district, as established by permit records or other historical documents accepted by the Building Official, or any building used for municipal operations by the City of Somerville may be changed to any use within the following principal use categories in accordance with Table 3.1 (a):
    - a). Artisan Production;
    - b). Arts Sales & Services;
    - c). Design Services;
    - d). Shared Workspace & Arts Education;
    - e). Consumer Goods; or
    - f). Fresh Food Market or Grocery.
- c. Increases in Density
  - i. Existing structures may not be altered to conflict with number of dwelling units permitted for each building type.
  - ii. The alteration or renovation of an existing building that results in any increase of the number of dwelling units requires a special permit.
    - a). In its discretion to approve or deny a Special Permit authorizing an increase in the number of dwelling units in an existing building, the Review Board shall consider the following:
      - i). the review considerations for all Special Permits as specified in §15.2.1.e. Review Criteria; and
      - ii). the quality of the living space in terms of functional area.

**TABLE 3.1 (a) NR Permitted Uses**

Use Category Specific Use	NR	Use Specific Standards
<b>Arts &amp; Creative Enterprise</b>		
Artisan Production	SP	§3.1.15.b & §9.2.2.a.ii
Arts Sales & Service	SP	§3.1.15.b & §9.2.2.c.ii
Design Services	SP	§3.1.15.b & §9.2.2.d.ii
Shared Workspaces & Arts Education	SP	§3.1.15.b & §9.2.2.f.ii
<b>Auto-Oriented</b>		
Motor Vehicle Parking (as noted below)	--	§9.2.3.d
Off-Site Accessory Parking	SP	§9.2.3.d.i
<b>Civic &amp; Institutional</b>		
Minor Utility Facility	SP	§9.2.4.d
Religious & Educational Uses Protected by M.G.L. 40A. Sec. 3	P	§9.2.4.h

P - Permitted      SP - Special Permit Required      N - Not Permitted

### 3. RESIDENTIAL DISTRICTS

Neighborhood Residence (NR)

**TABLE 3.1 (a) NR Permitted Uses (continued)**

Use Category Specific Use	NR	Use Specific Standards
<b>Commercial Services</b>		
Day Care Service (as noted below)	--	§9.2.5.h
Child Day Care Center	P	§9.2.5.h.ii
<b>Lodging</b>		
Bed & Breakfast	SP	§9.2.7.a
<b>Residential</b>		
Household Living	P	§9.2.9.a
Group Living (except as follows)	SP	§9.2.9.b
Community or Group Residence	P	§9.2.9.b.i
Dormitory, Fraternity, or Sorority	N	§9.2.9.b.ii
Homeless Shelter	N	§9.2.9.b.iii
Nursing Home/Assisted Living Facility	N	§9.2.9.b.iv
Rooming House	N	§9.2.9.b.v
<b>Retail Sales</b>		
Consumer Goods (except as follows)	P	§3.1.15.b and §9.2.10.b
Alcohol Sales	N	§9.2.10.b.i
Drug Paraphernalia Store	N	§9.2.10.b.ii
Firearms Sales	N	§9.2.10.b.iii
Medical Marijuana	N	§9.2.10.b.iv
Pet Store	N	§9.2.10.b.v
Fresh Food Market or Grocery Store	P	§9.2.10.d
<b>Urban Agriculture</b>		
Farming (as noted below)	--	§9.2.11.a
Commercial Farm	N	§9.2.11.a.i
Community Farm	P	§9.2.11.a.ii
Community Gardening	P	§9.2.11.b
<b>Accessory Uses</b>		
Home Occupations (as noted below)	--	§9.2.12.b
Creative Studio	P	§9.2.12.b.i
Hobby Kennel	SP	§9.2.12.b.ii
Home-Based Business	P	§9.2.12.b.iii
Home Day Care	SP	§9.2.12.b.iv
Home Office	P	§9.2.12.b.v
Tourist Home	P	§9.2.12.c
Urban Agriculture (as noted below)	--	§9.2.12.d
Apiculture	P	§9.2.12.d.i

P - Permitted      SP - Special Permit Required      N - Not Permitted

### 3. RESIDENTIAL DISTRICTS

Neighborhood Residence (NR)

**TABLE 3.1 (a) NR Permitted Uses (continued)**

Use Category Specific Use	NR	Use Specific Standards
Aviculture	P	§9.2.12.d.ii
Commercial Farming	P	§9.2.12.d.iii
Residential Gardening	P	§9.2.12.d.iv
<b>Vehicle Parking, Accessory (except as follows)</b>	<b>P</b>	<b>§9.2.12.e</b>
Home Business Vehicle Parking	SP	§9.2.12.f

P - Permitted      SP - Special Permit Required      N - Not Permitted

**16. Vehicular Parking**

- a. General
  - i. Vehicular parking must be provided as specified on Table 3.1 (b), except as follows:
    - a). Non-residential uses with five thousand (5,000) square feet or less of gross leasable floor area are exempt from the requirements of Table 3.1 (b).
  - ii. There are no parking requirements for accessory uses.
  - iii. Parking may be shared between uses on the same lot and buildings on the same block in accordance with §12.3 Shared Parking.
  - iv. One (1) on street parking space for every twenty (20) feet of lot width may be counted if residential permit parking is permitted along the same side of the street as the lot the spaces will serve.
- b. Type
  - i. Motor vehicle parking may be provided as surface parking spaces, structured parking spaces, and on-street parking spaces.
- c. Unbundled Parking

**TABLE 3.1 (b) NR Parking**

\*See the Transit Area Map

Use Category Specific Use	BICYCLE		MOTOR VEHICLE	
	Short-Term (min)	Long-Term (min)	Within a Transit Area* (max)	Outside of a Transit Area* (min)
<b>Arts &amp; Creative Enterprise</b>				
Artisan Production	1.0 / 10,000 sf	1.0 / 3,000 sf	n/a	1.0 / 1,000 sf
Arts Sales & Service	1.0 / 10,000 sf	1.0 / 3,000 sf	n/a	1.0 / 1,000 sf
Design Services	1.0 / 10,000 sf	1.0 / 3,000 sf	n/a	1.0 / 1,000 sf
Shared Workspace & Arts Education	1.0 / 10,000 sf	1.0 / 3,000 sf	n/a	1.0 / 650 sf
<b>Lodging</b>				
Bed & Breakfast	1.0 / 20 rooms	1.0 / 10 rooms	n/a	1 / 4 rooms
Short Term Rental	1.0 / 20 rooms	1.0 / 10 rooms	n/a	1 / DU
<b>Residential</b>				
Household Living	n/a	n/a	n/a	1 / DU
Group Living	n/a	n/a	n/a	1 / DU
<b>Retail Sales</b>				
Consumer Goods	1.0 / 2,500 sf	1.0 / 10,000 sf	n/a	1 / 1,500 sf
Fresh Food Market or Grocery Store	1.0 / 2,500 sf	1.0 / 10,000 sf	n/a	1 / 1,500 sf

sf - Gross Leasable Square Footage      DU - Dwelling Unit      RU - Rooming Unit

### 3. RESIDENTIAL DISTRICTS

#### Neighborhood Residence (NR)

- i. Motor vehicle parking spaces must be rented, leased, or sold as an option rather than a requirement of the rental, lease, or purchase of a dwelling unit or non-residential floor space.
- d. Parking Location
  - i. Required vehicular parking, excluding any required handicapped parking, may be provided on a contiguous lot under the same ownership as the lot that the parking will serve according to the following:
    - a). Pedestrian access to off-site vehicular parking must be via a paved sidewalk or walkway.
    - b). A lease, recorded covenant, or other comparable legal instrument guaranteeing long term use of the site must be provided to the review board or building official and executed and filed with the Registry of Deeds.
  - ii. For real property located in more than one municipality, motor vehicle parking need not be located within the City of Somerville.
- e. Parking Relief
  - i. Relief from the parking standards of Table 3.1 (b) requires a special permit.
    - a). In its discretion to approve or deny a special permit authorizing relief from the parking standards of Table 3.1 (b), the review board shall consider the following:
      - i). The supply and demand of on-street parking in the neighborhood, as determined through a parking study.
      - ii). Mobility management programs and services provided by the applicant to reduce the demand for parking.
      - iii). That parking provided in excess of any maximum permitted does not result in the increase in impervious lot area.
- building and any front lot line.
- c). Driveways may be no wider than twelve (12) feet in width at the frontage.
- d). Driveways may provide access in whole or in part on or across an abutting lot(s), provided that an access easement exists between all property owners.
- iii. Curb Cuts
  - a). Unless otherwise specified, only one (1) curb cut is permitted per front lot line.
  - b). Curb cuts must be located to minimize conflict with pedestrians, bicyclists, and motor vehicles on the thoroughfare they provide access to and from.
  - c). Curb cuts may be no wider than the driveway or vehicular entrance they serve, excluding flares or returned curbs.
- iv. Driveway and Alley Crossings
  - a). Driveways and alleys traversing sidewalks must be designed to maintain the grade and clear width of the walkway they cross and must include returned curbs.
  - b). The appearance of any walkway (ie. scoring pattern or special paving) must be maintained across any driveway or alley to indicate that, although a vehicle may cross, the area traversed by a vehicle remains part of the sidewalk.
- c. Signs
  - i. A sign, individual numerals or letters, or a nonelectrical nameplate identifying the property address is required for all real property as follows:
    - a). Each ground story non-residential use must identify the street address either on the principal entrance door or above or beside the principal entrance of the use.
    - b). All residential building types must identify the street address either on the principal entrance door, above or beside the principal entrance, or on a mailbox.
  - ii. Address signs must be made easily visible through the use of colors or materials that contrast with the background material they are attached to and must be conspicuously located to provide visibility from the thoroughfare that the building faces.
  - iii. Address signs must be twelve (12) inches or less in height and may include the name of the occupant.

#### 17. Site Development

- a. General
  - i. Development is subject the provisions of Article 10: Development Standards of this Ordinance. Where the provisions of this section conflict with those of Article 10, the provisions of Article 10 apply.
- b. Parking Design
  - i. General
    - a). Bicycle and motor vehicle parking is subject to **§10.7 Parking Design** of this Ordinance.
  - ii. Driveways
    - a). Ribbon driveways should be used to every extent feasible.
    - b). Driveways may provide access from a front, side, or rear lot line and may be located within a required front, side, and rear setback areas, but are prohibited between the facade of a



## 3.2 URBAN RESIDENCE (UR)

### 1. Character Description

The Urban Residence district is characterized by a variety of moderate floor plate, multi-unit buildings where outdoor amenity space is typically shared between the residents of a building. The district is almost entirely residential, with occasional neighborhood stores, schools, places of worship, and arts related uses on advantageous sites. This district can provide a transition between Neighborhood Residence and the Mid-Rise, High-Rise, and Commercial Districts when mapped accordingly.



# 3. RESIDENTIAL DISTRICTS

Urban Residence (UR)

## 2. Intent

- a. To implement the Urban Residential context from the Future Land Context Map of SomerVision.
- b. To create, maintain, and enhance areas appropriate for multi-unit residential buildings.

## 3. Purpose

- a. To permit the development of multi-unit detached and semi-detached residential buildings on individual lots.
- b. To permit contextual modifications to existing detached and semi-detached residential buildings.
- c. To permit the adaptive reuse of certain existing nonconforming buildings for arts & creative enterprise and retail uses compatible with residential areas.

## 4. Applicability

- a. The section is applicable to all real property within the Urban Residence district as shown on the maps of the Official Zoning Atlas of the City of Somerville.

## 5. Development Review

- a. Development on any lot requires the submittal of a development review application to the Building Official and the issuance of a Certificate of Zoning Compliance.
- b. A pre-submittal meeting is recommended for all development.
- c. Proposed development may or may not necessitate the need for a Special Permit or a Variance based on the nature of the proposal. In such cases, additional development review is required in accordance with Article 15: Administration.
  - i. The Zoning Board of Appeals is the decision making authority for all development that requires a Special Permit in the Urban Residence district.

- d. Upon completion of the required development review, a Certificate of Zoning Compliance shall be issued by the Building Official to certify compliance with the provisions and procedures of this Ordinance.

## 6. Building Types

- a. One (1) principal building type may be built on each lot.
- b. The following principal building types are permitted in the Neighborhood Residence district:
  - i. Detached Triple Decker
  - ii. Semi-Detached Triple Decker
  - iii. Multi-Plex
  - iv. Apartment House
  - v. Apartment Building
  - vi. Row Houses
- c. Accessory structures are regulated according to Article 10: Development Standards of this Ordinance.



#### 7. Detached Triple Decker

A moderate floor plate, detached, residential building type with three vertically stacked dwelling units.

The following images are examples from Somerville of the detached triple decker building type and are intended only for illustrative purposes.



# 3. RESIDENTIAL DISTRICTS

Urban Residence (UR)

## 7. Detached Triple Decker (continued)

a. Lot Standards

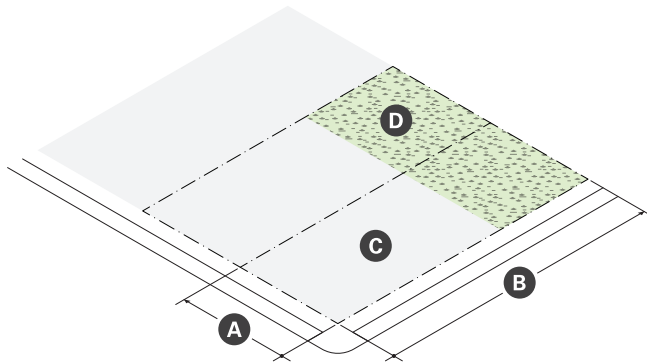

Lot Dimensions	
<b>A</b> Width (min)	--
No Driveway Access	34 ft
Side or Rear Driveway Access	34 ft
Front Driveway Access	37 ft
<b>B</b> Depth (min)	80 ft

Lot Development	
<b>C</b> Lot Coverage (max)	65%
<b>D</b> Green Factor (min)	0.35

b. Building Placement

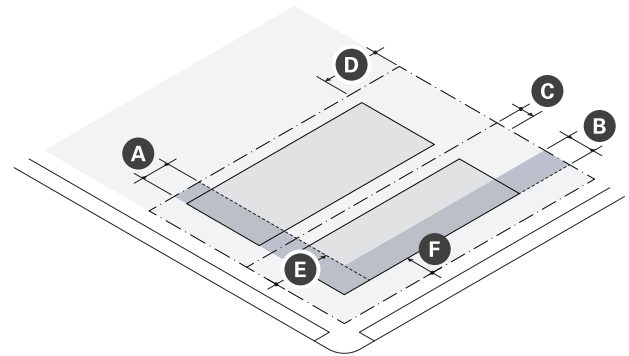

Building Setbacks		
<b>A</b> Primary Front Setback (min/max)	10 ft	20 ft
<b>B</b> Secondary Front Setback (min/max)	10 ft	20 ft
<b>C</b> Side Setback (min)	5 ft	
<b>D</b> Rear Setback (min)	20 ft	

Parking Setbacks	
<b>E</b> Primary Front Setback (min)	20 ft
<b>F</b> Secondary Front Setback (min)	10 ft

## 7. Detached Triple Decker (continued)

c. Massing & Height

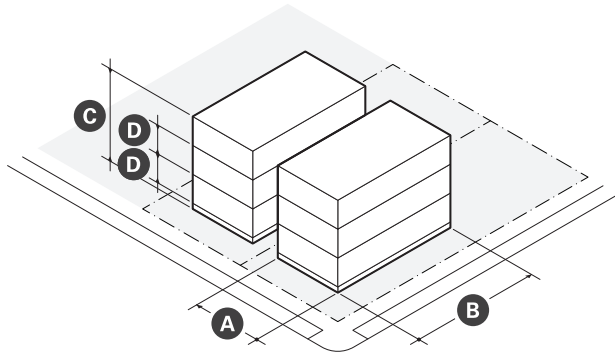

Main Body	
Facade Build Out (min)	60%
<b>A</b> Width (min/max)	24 ft 20 ft
<b>B</b> Depth (min/max)	36 ft 50 ft
<b>C</b> Building Height (max)	3 stories
<b>D</b> Story Height (min/max)	10 ft 12 ft
Ground Floor Elevation (min)	2 ft
Roof Type	Flat

d. Uses & Features

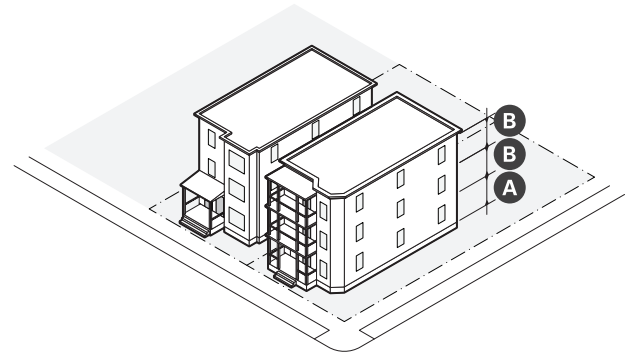

Facade Composition		
<b>A</b> Ground Story Fenestration (min/max)	20%	50%
<b>B</b> Upper Story Fenestration (min/max)	20%	50%

Use & Occupancy	
Dwelling Units (max)	3
Outdoor Amenity Space (min)	1/ DU

### 3. RESIDENTIAL DISTRICTS

Urban Residence (UR)

- e. Housing
  - i. There is no affordable housing requirement for a detached triple decker.

**FIGURE 3.2 (a) Dwelling Unit Orientation**

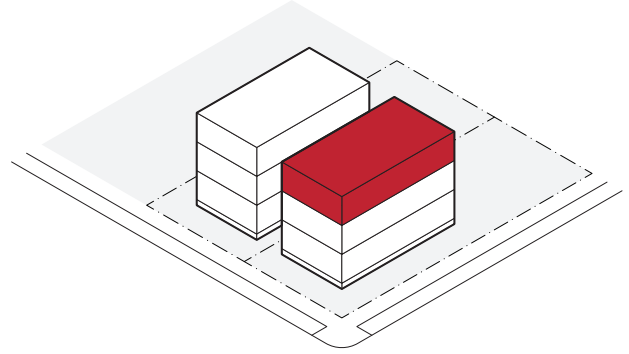

#### 8. Semi-Detached Triple Decker

A moderate floor plate, semi-detached, residential building type with three vertically stacked dwelling units. A semi-detached triple decker must be attached on one side to another semi-detached triple decker by a party wall.

The following images are examples from Somerville of the semi-detached triple decker building type and are intended only for illustrative purposes.



# 3. RESIDENTIAL DISTRICTS

Urban Residence (UR)

## 8. Semi-Detached Triple Decker (continued)

a. Lot Standards

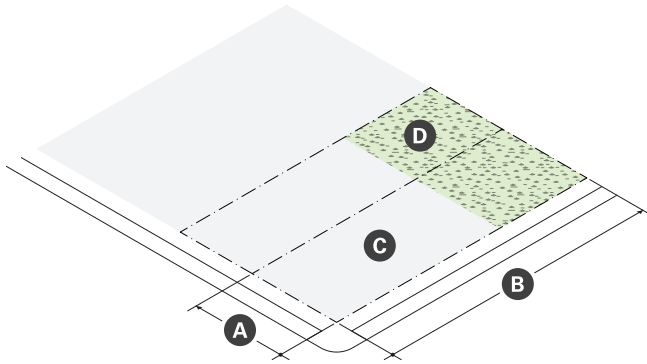

Lot Dimensions	
<b>A</b> Width (min)	--
No Driveway Access	29 ft
Side or Rear Driveway Access	29 ft
Front Driveway Access	32 ft
<b>B</b> Depth (min)	80 ft

Lot Development	
<b>C</b> Lot Coverage (max)	65%
<b>D</b> Green Factor (min)	0.35

b. Building Placement

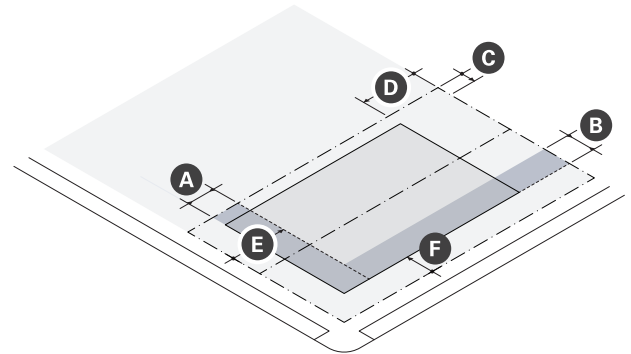

Building Setbacks		
<b>A</b> Primary Front Setback (min/max)	10 ft	20 ft
<b>B</b> Secondary Front Setback (min/max)	10 ft	20 ft
<b>C</b> Side Setback (min)		
Party Lot Line	0 ft	
Side Lot Line	5 ft	
<b>D</b> Rear Setback (min)	20 ft	

Parking Setbacks	
<b>E</b> Primary Front Setback (min)	20 ft
<b>F</b> Secondary Front Setback (min)	10 ft



## 8. Semi-Detached Triple Decker (continued)

c. Massing & Height

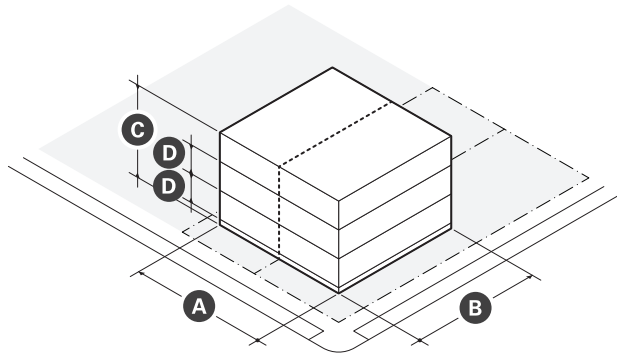

Main Body	
Facade Build Out (min)	60%
<b>A</b> Width (min/max)	24 ft 30 ft
<b>B</b> Depth (min/max)	36 ft 50 ft
<b>C</b> Building Height (max)	3 stories
<b>D</b> Story Height (min/max)	10 ft 12 ft
Ground Floor Elevation (min)	2 ft
Roof Type	Flat

d. Uses & Features

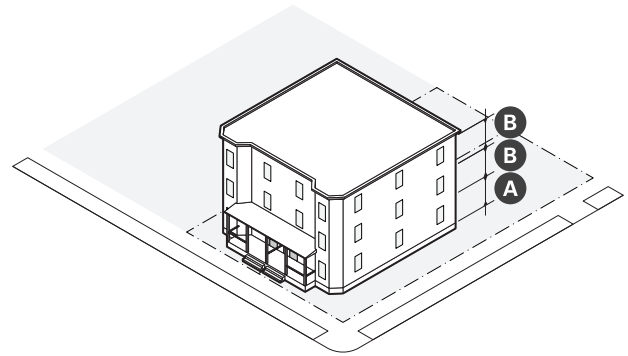

Facade Composition		
<b>A</b> Ground Story Fenestration (min/max)	20%	50%
<b>B</b> Upper Story Fenestration (min/max)	20%	50%

Use & Occupancy	
Dwelling Units (max)	3
Outdoor Amenity Space (min)	1/ DU

### 3. RESIDENTIAL DISTRICTS

Urban Residence (UR)

- e. Housing
  - i. There is no affordable housing requirement for a semi-detached triple decker.

**FIGURE 3.2 (b) Dwelling Unit Orientation**

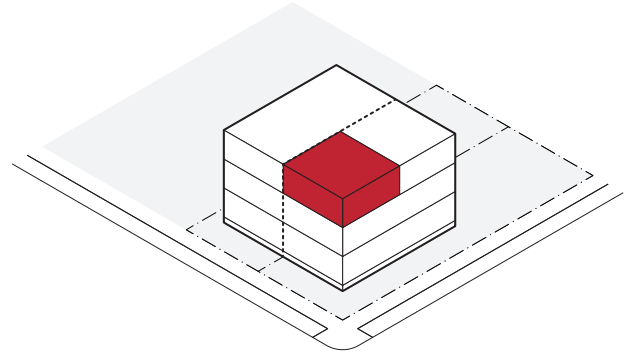

### 3. RESIDENTIAL DISTRICTS

Urban Residence (UR)

#### 9. Multi-Plex

A moderate floor plate, detached, residential building type with four to six dwelling units.

The following images are examples from Somerville of the multi-plex building type and are intended only for illustrative purposes.



# 3. RESIDENTIAL DISTRICTS

Urban Residence (UR)

## 9. Multi-Plex (continued)

### a. Lot Standards

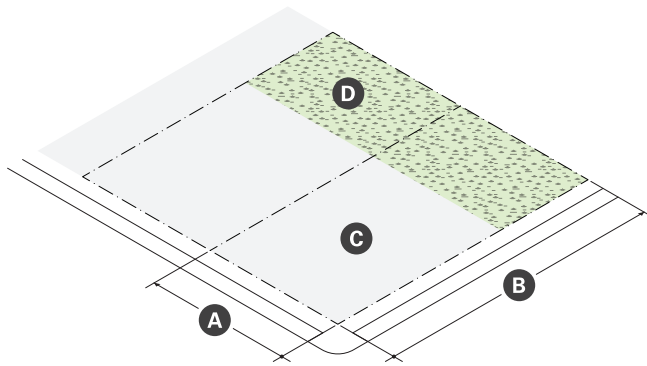

Lot Dimensions	
<b>A</b> Width (min)	--
No Driveway Access	46 ft
Side or Rear Driveway Access	46 ft
Front Driveway Access	49 ft
<b>B</b> Depth (min)	85 ft

Lot Development	
<b>C</b> Lot Coverage (max)	65%
<b>D</b> Green Factor (min)	0.35

### b. Building Placement

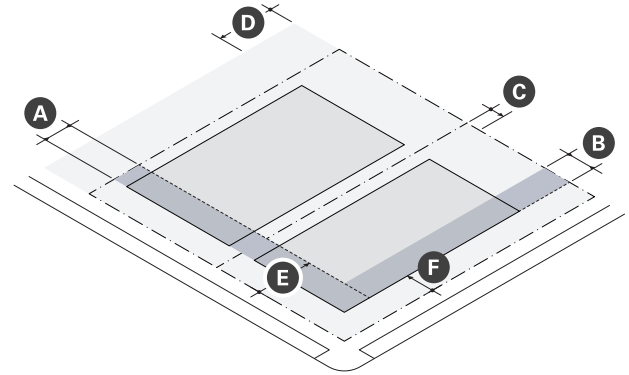

Building Setbacks		
<b>A</b> Primary Front Setback (min/max)	10 ft	20 ft
<b>B</b> Secondary Front Setback (min/max)	10 ft	20 ft
<b>C</b> Side Setback (min)	5 ft	
<b>D</b> Rear Setback (min)	20 ft	

Parking Setbacks	
<b>E</b> Primary Front Setback (min)	20 ft
<b>F</b> Secondary Front Setback (min)	10 ft

## 9. Multi-Plex (continued)

c. Massing & Height

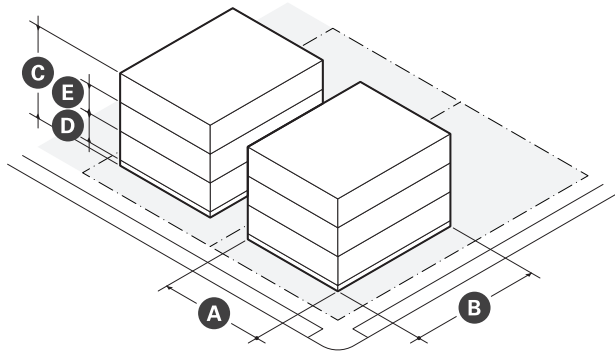

d. Uses & Features

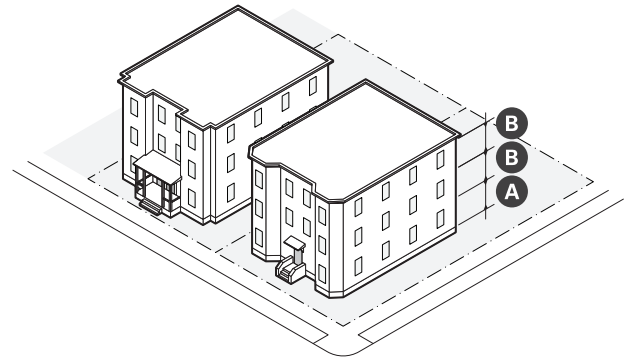

Main Body	
Facade Build Out (min)	70%
<b>A</b> Width (min/max)	36 ft 50 ft
<b>B</b> Depth (min/max)	44 ft 64 ft
<b>C</b> Building Height (max)	3 stories
<b>D</b> Story Height (min/max)	10 ft 12 ft
Ground Floor Elevation (min)	2 ft
Roof Type	Flat, Gable, Hip

Facade Composition	
<b>A</b> Ground Story Fenestration (min/max)	20% 50%
<b>C</b> Upper Story Fenestration (min/max)	20% 50%

Use & Occupancy	
Dwelling Units (max)	6
Outdoor Amenity Space (min)	1/ DU

### 3. RESIDENTIAL DISTRICTS

Urban Residence (UR)

- e. Housing
  - i. There is no affordable housing requirement for a multi-plex.

**FIGURE 3.2 (c) Dwelling Unit Orientation**

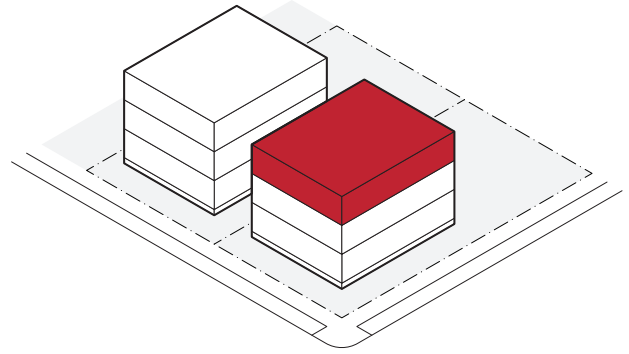

#### 10. Apartment House

A moderate floor plate, detached, residential building type with six to ten dwelling units designed to appear as a large house.

The following images are primarily examples from Somerville of the apartment house building type and are intended only for illustrative purposes.



# 3. RESIDENTIAL DISTRICTS

Urban Residence (UR)

## 10. Apartment House (continued)

a. Lot Standards

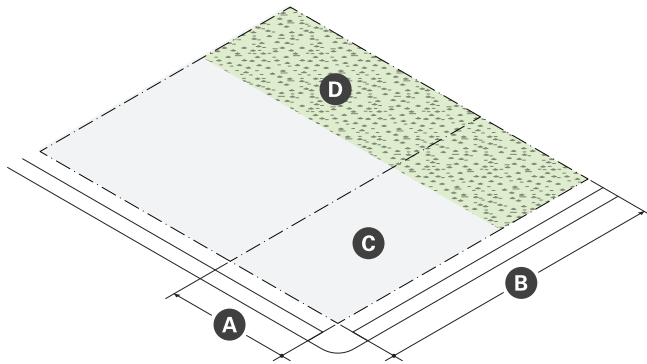

Lot Dimensions	
<b>A</b> Width (min)	--
No Driveway Access	38 ft
Side or Rear Driveway Access	38 ft
Front Driveway Access	41 ft
<b>B</b> Depth (min)	100 ft

Lot Development	
<b>C</b> Lot Coverage (max)	65%
<b>D</b> Green Factor (min)	0.35

b. Building Placement

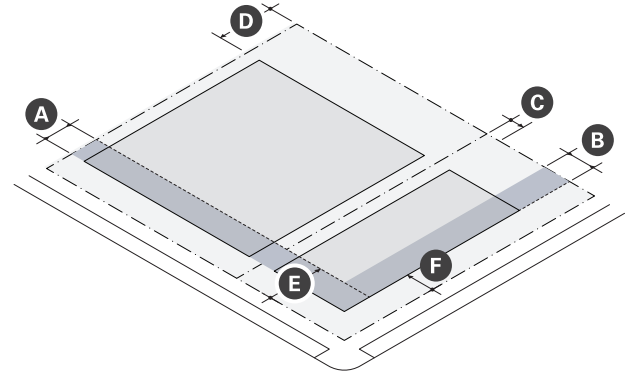

Building Setbacks		
<b>A</b> Primary Front Setback (min/max)	10 ft	20 ft
<b>B</b> Secondary Front Setback (min/max)	10 ft	20 ft
<b>C</b> Side Setback (min)	5 ft	
<b>D</b> Rear Setback (min)	20 ft	

Parking Setbacks	
<b>E</b> Primary Front Setback (min)	20 ft
<b>F</b> Secondary Front Setback (min)	10 ft



## 10. Apartment House (continued)

c. Massing & Height

d. Uses & Features

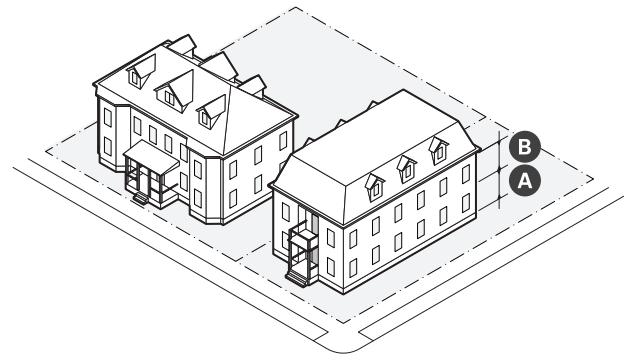
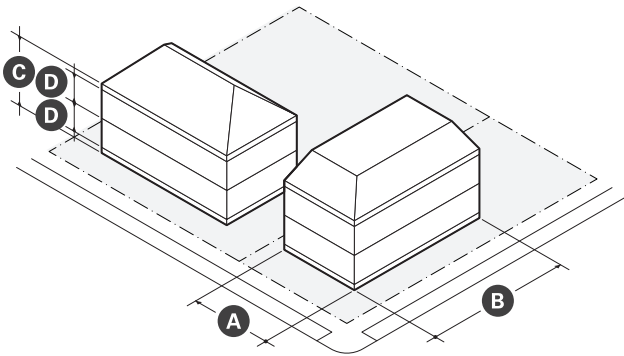

Main Body	
Facade Build Out (min)	70%
<b>A</b> Width (min/max)	28 ft 56 ft
<b>B</b> Depth (min/max)	44 ft 68 ft
<b>C</b> Building Height (max)	2.5 stories
<b>D</b> Story Height (min/max)	10 ft 12 ft
Ground Floor Elevation (min)	2 ft
Roof Type	Gable, Hip, Mansard

Facade Composition	
<b>A</b> Ground Story Fenestration (min/max)	20% 50%
<b>B</b> Upper Story Fenestration (min/max)	20% 50%

Use & Occupancy	
Dwelling Units (max)	10
Outdoor Amenity Space (min)	1/ DU

### 3. RESIDENTIAL DISTRICTS

Urban Residence (UR)

- e. Housing
  - i. An apartment house with more than six units must provide affordable housing in accordance with Article 13.

**FIGURE 3.2 (d) Dwelling Unit Orientation**

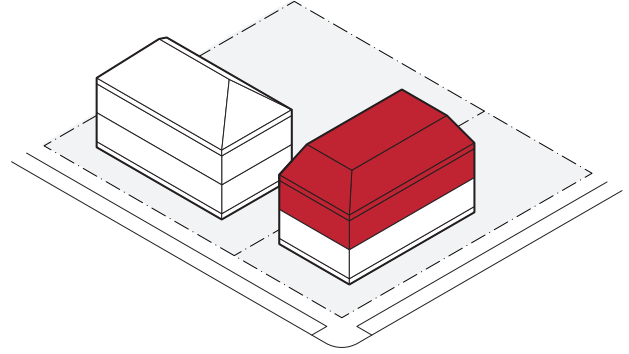

#### 11. Apartment Building

A moderate floorplate, multi-story building type with more than six dwelling units.

The following images are examples of the apartment building type and are intended only for illustrative purposes.



# 3. RESIDENTIAL DISTRICTS

Urban Residence (UR)

## 11. Apartment Building (continued)

a. Lot Standards

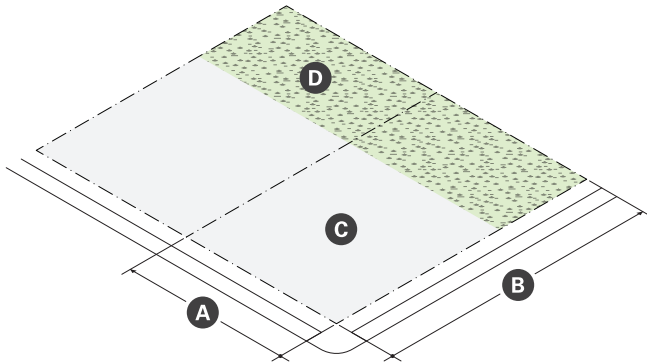

Lot Dimensions	
<b>A</b> Width (min)	--
No Driveway Access	55 ft
Side or Rear Driveway Access	55 ft
Front Driveway Access	58 ft
<b>B</b> Depth (min)	90 ft

Lot Development	
<b>C</b> Lot Coverage (max)	65%
<b>D</b> Green Factor (min)	0.35

b. Building Placement

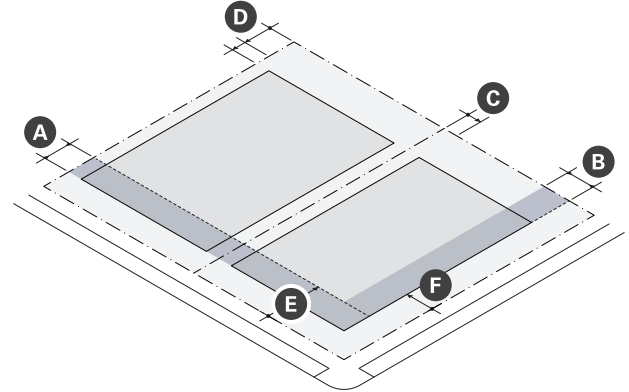

Building Setbacks		
<b>A</b> Primary Front Setback (min/max)	10 ft	20 ft
<b>B</b> Secondary Front Setback (min/max)	10 ft	20 ft
<b>C</b> Side Setback (min)	5 ft	
Side Setback Abutting NR (min)	20 ft	
<b>D</b> Rear Setback (min)	10 ft	
Rear Setback Abutting NR (min)	20 ft	

Parking Setbacks		
<b>E</b> Primary Front Setback (min)	--	
Surface Parking	20 ft	
Structured Parking	20 ft	
<b>F</b> Secondary Front Setback (min)	--	
Surface Parking	10 ft	
Structured Parking	10 ft	

## 11. Apartment Building (continued)

c. Massing & Height

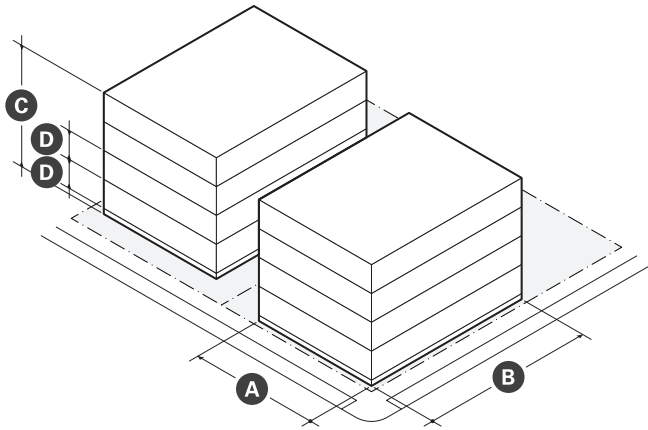

Main Body	
Facade Build Out (min)	80%
<b>A</b> Floor Plate (max)	7,000 sf
<b>B</b> Building Height (min)	2 stories
<b>C</b> Building Height (max)	4 stories
<b>D</b> Story Height (min/max)	10 ft 12 ft
Ground Floor Elevation (min)	2 ft
Roof Type	Flat, Mansard

d. Uses & Features

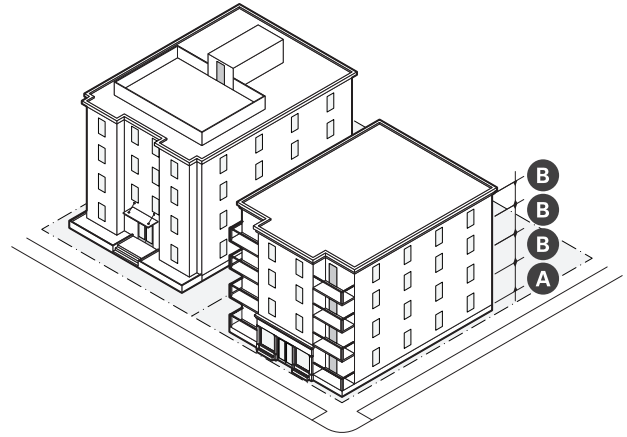

Facade Composition	
<b>A</b> Ground Story Fenestration (min/max)	20% 50%
<b>B</b> Upper Story Fenestration (min/max)	20% 50%

Use & Occupancy	
Dwelling Units (min)	<b>7</b>
Density Factor	<b>1,350</b>
Outdoor Amenity Space (min)	1/ DU

### 3. RESIDENTIAL DISTRICTS

Urban Residence (UR)

- e. Housing
  - i. An apartment building with more than six (6) dwelling units must provide affordable housing in accordance with Article 13.

**FIGURE 3.2 (e) Dwelling Unit Orientation**

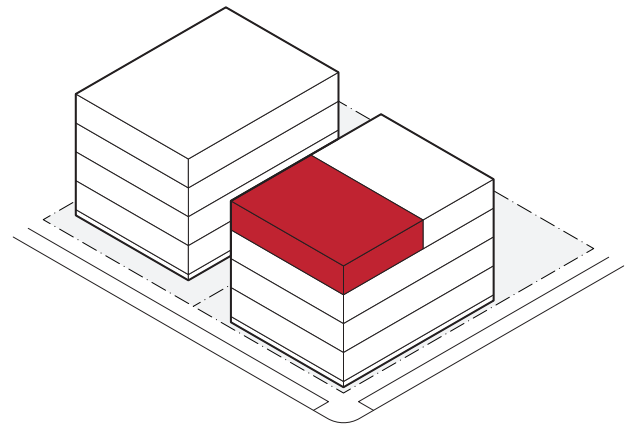

## 12. Row Houses

A series of three (3) or more small floor plate, attached, residential buildings, each with one (1) dwelling unit.

The following images are examples from Somerville of the row houses building type and are intended only for illustrative purposes.



# 3. RESIDENTIAL DISTRICTS

Urban Residence (UR)

## 12. Row Houses (continued)

a. Lot Standards

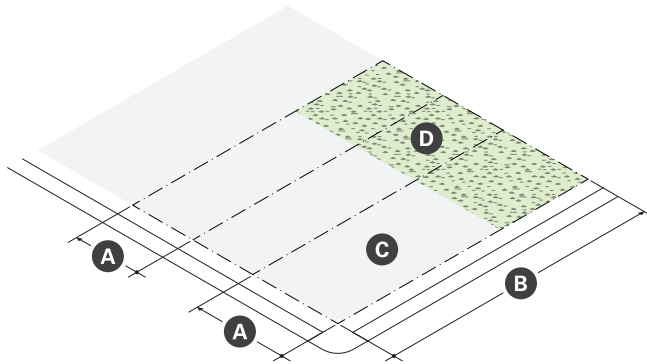

Site Dimensions	
Width (min/max)	82 ft 250 ft

Lot Dimensions	
<b>A</b> Width (min)	--
Interior Lot in Sequence	--
No Driveway Access	24 ft
End Lot in Sequence	--
No Driveway Access	29 ft
Side or Rear Driveway Access	29 ft
Front Driveway Access	32 ft
<b>B</b> Depth (min)	80 ft

Lot Development	
<b>C</b> Lot Coverage (max)	65%
<b>D</b> Green Factor (min)	0.35

b. Building Placement

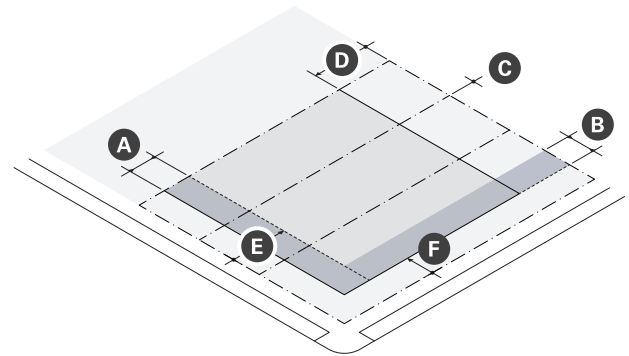

Building Setbacks	
<b>A</b> Primary Front Setback (min/max)	10 ft 20 ft
<b>B</b> Secondary Front Setback (min/max)	10 ft 20 ft
<b>C</b> Side Setback (min)	5 ft
<b>D</b> Rear Setback (min)	20 ft

Parking Setbacks	
<b>E</b> Primary Front Setback (min)	20 ft
<b>F</b> Secondary Front Setback (min)	10 ft



**12. Row Houses (continued)**

c. Massina & Height

d. Uses & Features

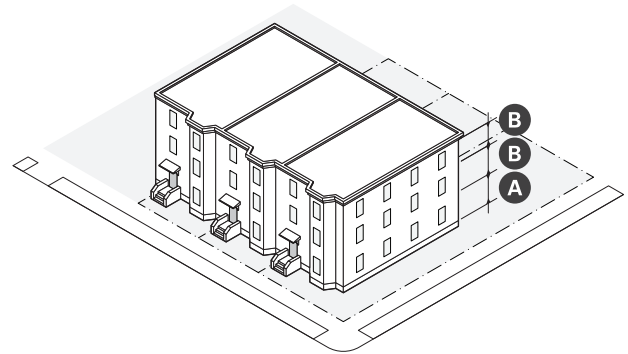
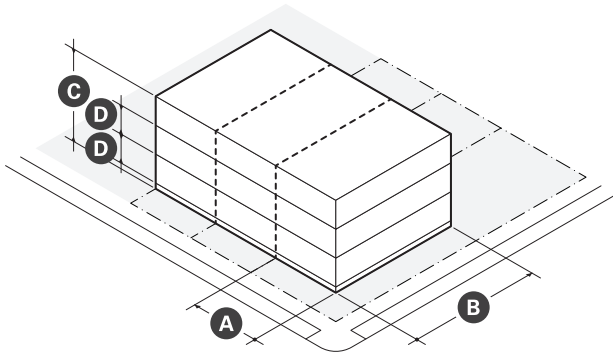

Main Body	
Facade Build Out (min)	70%
<b>A</b> Width (min/max)	24 ft 30 ft
<b>B</b> Depth (min/max)	34 ft 60 ft
<b>C</b> Building Height (min)	2 stories
Building Height (max)	3 stories
<b>D</b> Story Height (min/max)	10 ft 12 ft
Ground Floor Elevation (min)	2 ft
Roof Type	Flat, Gable, Mansard

Facade Composition		
<b>A</b> Ground Story Fenestration (min/max)	20%	50%
<b>B</b> Upper Story Fenestration (min/max)	20%	50%

Use & Occupancy		
Dwelling Units per Site (min/max)	3	10
Dwelling Units per Row House (max)	1	
Outdoor Amenity Space (min)	1/ DU	

### 3. RESIDENTIAL DISTRICTS

Urban Residence (UR)

- e. Housing
  - i. A sequence of six (6) or more row houses must provide affordable housing in accordance with Article 13.

**FIGURE 3.2 (f) Dwelling Unit Orientation**

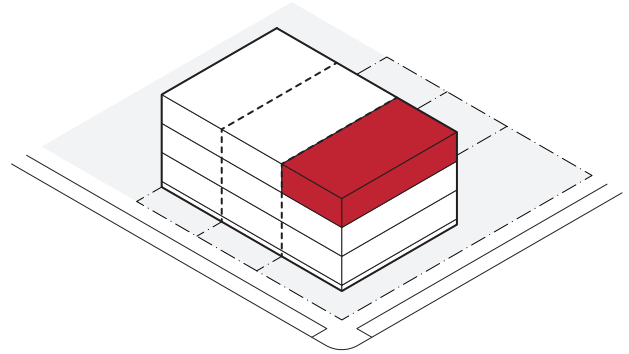

### 13. Building Components

- a. Building components are accessory features that increase the habitable square footage or enhance the usefulness of a building.
- b. Building components are permitted as specified on Table 3.2 (a).
- c. Structures such as decks, stoops, porticos, and porches attached to the side or rear of the main body of a principal building type are permitted provided that they do not violate any side or rear setback.

**TABLE 3.2 (a) Permitted Building Components**

	Entry Canopy	Bay	Dormer Window	Cross Gable	Balcony	Roof Deck	Specific Standards
Triple Decker	P	P	N	N	P	P	§3.2.7
Semi-Detached Triple Decker	P	P	N	N	P	P	§3.2.8
Multi-Plex	P	P	Y	Y	P	P	§3.2.9
Apartment House	P	P	Y	Y	P	P	§3.2.10
Apartment Building	P	P	N	N	P	P	§3.2.11
Rowhouses	P	P	Y	N	P	P	§3.2.12

P - Permitted      SP - Special Permit Required      N - Not Permitted

# 3. RESIDENTIAL DISTRICTS

Urban Residence (UR)

## D. Entry Canopy

- i. An entry canopy is a wall-mounted structure that provides shade and weather protection over the entrance of a building.

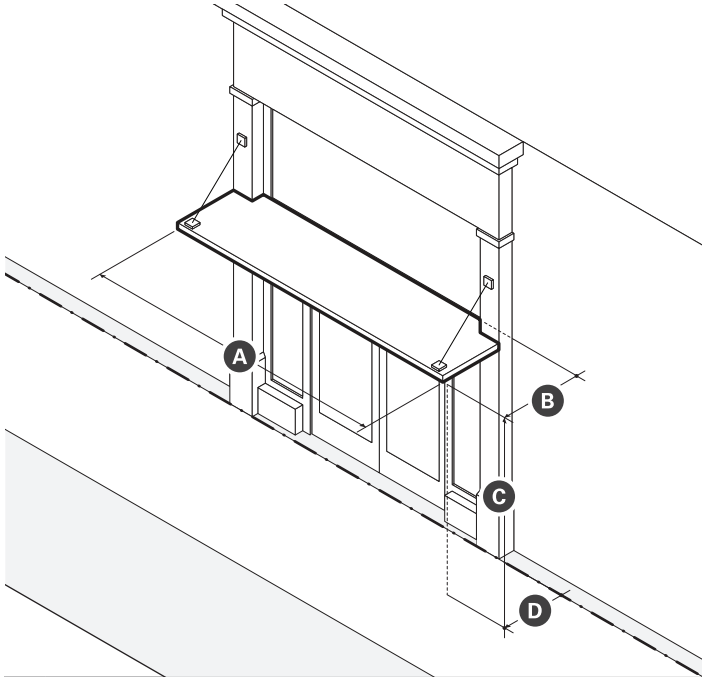

Dimensions	
<b>A</b> Width (min)	See §D.ii.b
<b>B</b> Depth (max)	3 ft
<b>C</b> Clearance (min)	8 ft clear
<b>D</b> Permitted Setback Encroachment (max)	100%

- ii. Standards
  - a). Entry canopies must be visually supported by brackets, cables, or rods.
  - b). The width of an entry canopy must be equal to or greater than the width of the doorway surround or exterior casing it is mounted over.

## E. Bay

- i. A bay is a window assembly extending from the main body of a building to permit increased light, provide multi-direction views, and articulate a building's facade.

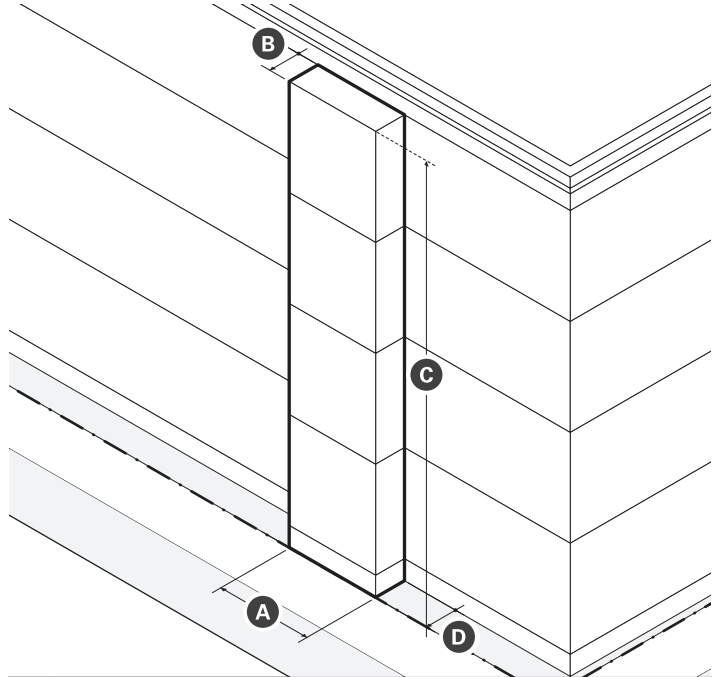

Dimensions	
<b>A</b> Width (min)	50% of facade or elevation
<b>B</b> Depth (max)	3 ft
<b>C</b> Height (max)	Height of Building
Fenestration (min)	60%
<b>D</b> Permitted Setback Encroachment (max)	3 ft

- ii. Standards
  - a). Bays must have a foundation extending all the way to ground level or be visually supported by brackets or other architectural supports.
  - b). Bays projecting over the sidewalk of a public thoroughfare must have two (2) stories of clearance and compliance with all City Ordinances.

## F. Dormer Window

- i. A dormer window is a single window or set of windows that projects vertically from a sloped roof, designed to provide light into and expand the habitable space of a half-story.

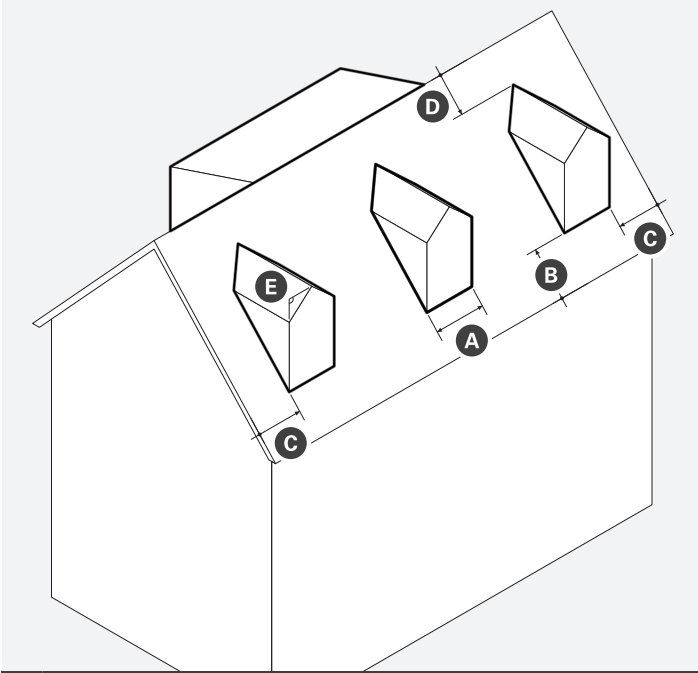

Dimensions	
<b>A</b> Width (max)	24 feet or 50% of the eave length of the main roof (whichever is shorter)
<b>B</b> Front & Rear Wall Setback (min)	3 ft 6 in
<b>C</b> Side Wall Setback (min)	1 ft 6 in
<b>D</b> Ridge Line Setback (min)	1 ft
<b>E</b> Roof Slope (min)	4:12 (18.43°)
Fenestration (min)	70%

- ii. Standards
  - a). Setbacks are strictly enforced regardless of permitted dormer width.
  - b). The maximum permitted width of a dormer applies to single, multiple, or attached combinations of dormers on each side of a roof.

## G. Cross Gable

- i. A cross gable is a sloped roof that projects perpendicularly from the main roof of a building to significantly increase the habitable space of a half-story.

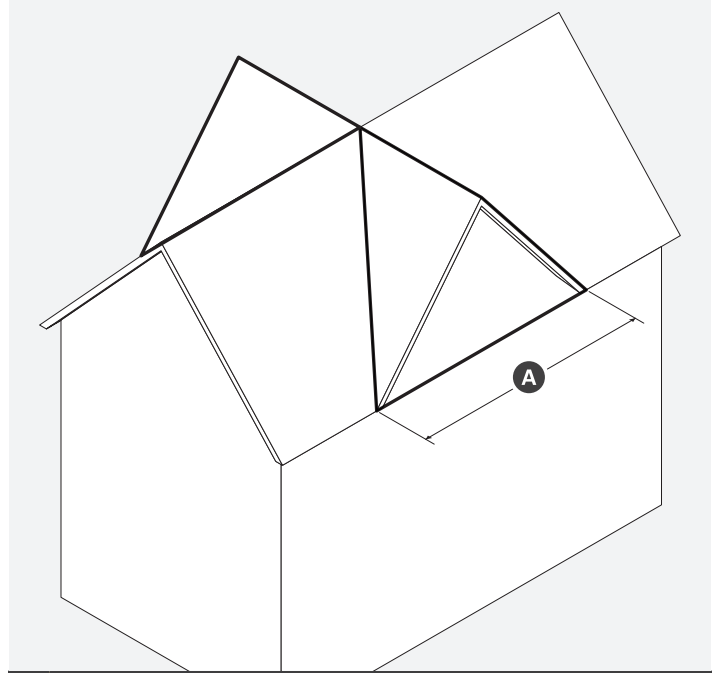

Dimensions	
<b>A</b> Width (max)	50% of the eave length of the main roof

- ii. Standards
  - a). The rakes of the cross gable roof must be structurally integrated into the eave and ridge line of the main roof.

### 3. RESIDENTIAL DISTRICTS

Urban Residence (UR)

#### H. Balcony

- i. A balcony is a platform with a railing that provides outdoor amenity space.

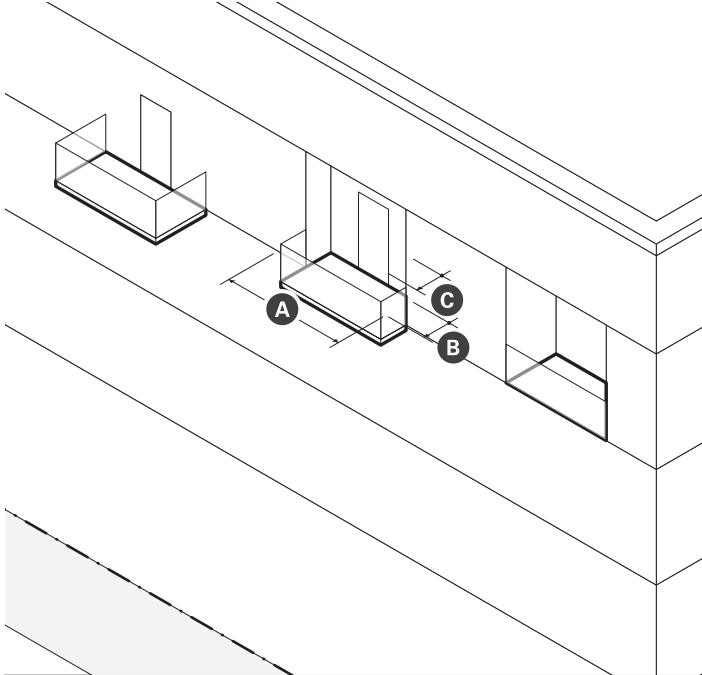

Dimensions	
<b>A</b> Width (min)	5 ft
<b>B</b> Depth (min)	5 ft
Area (min)	50 sf
Clearance (min)	10 ft
<b>C</b> Permitted Setback Encroachment (max)	6 ft

- ii. Standards
  - a). Balconies may be recessed, projecting, a combination of the two, or terraced as part of the roof of a portico, porch, or bay.
  - b). A balcony that projects over the sidewalk of a public thoroughfare requires compliance with all City Ordinances.
  - c). The guard rail of any balcony oriented toward a front lot line must permit visual supervision of the public realm through the posts and rails.
  - d). The guard rail of any balcony oriented toward a side or rear lot line abutting the NR district must include sight obscuring visual screening so that it is at least fifty percent (50%) opaque.

#### I. Roof Deck

- i. A roof deck is a roofless, raised platform on the roof of a building that provides outdoor amenity space.

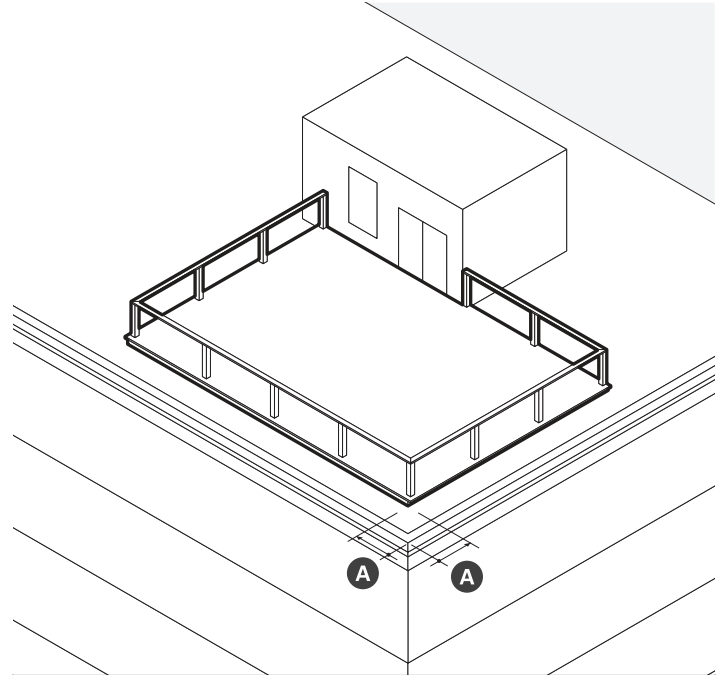

Dimensions	
<b>A</b> Setback from Facade (min)	5 ft
Railing Height (max)	4 ft

- ii. Standards
  - a). Roof decks are only permitted on flat roofs.
  - b). The flooring of a roof deck must be no more than two feet above the roof supporting the deck.
  - c). Roof decks located within five (5) feet of a side rear lot line abutting the NR district must provide sight obscuring visual screening so that it is at least fifty percent (50%) opaque.
  - d). Roof deck access structures, such as stairwell penthouses, may not exceed 10 ft. in height and may only serve to enclose the access stairs.

#### 14. Private Frontage

- a. Private frontage must be designed as a building frontage type.
- b. Building frontage types facilitate access to principal entrances and serve as the interface and transition between the private realm (building interiors) and the public realm (sidewalks and civic spaces).
- c. Building frontage types are permitted according as specified on Table 3.2 (b).
- d. Building frontage types may be combined as specified for each type and multiple frontage types may exist for buildings that have more than one principal entrance.

**TABLE 3.2 (b) Permitted Building Frontages**

	Stoop	Portico	Projecting Porch	Dooryard	Forecourt	Lobby Entrance	Lightwell	Specific Standards
Triple Decker	P	P	P	P	N	N	N	§3.2.7
Semi-Detached Triple Decker	P	P	P	P	N	N	N	§3.2.8
Multi-Plex	P	P	P	P	N	N	N	§3.2.9
Apartment House	P	P	P	P	N	N	N	§3.2.10
Apartment Building	P	P	N	P	P	P	P	§3.2.11
Rowhouses	P	P	P	P	N	N	P	§3.2.12

P - Permitted      SP - Special Permit Required      N - Not Permitted

### 3. RESIDENTIAL DISTRICTS

Urban Residence (UR)

#### E. Stoop

- i. A stoop is a frontage type featuring a set of stairs with a landing leading to the entrance of a building.

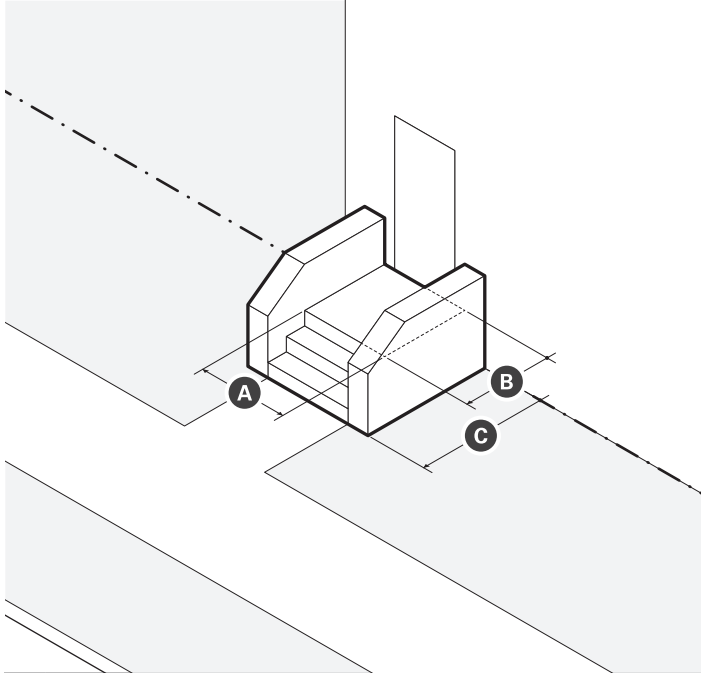

Dimensions	
<b>A</b> Landing Width (min)	4 ft
<b>B</b> Landing Depth (min)	4 ft
<b>C</b> Permitted Front Setback Encroachment (max)	100%

- ii. Standards
  - a). Paving, excluding driveways, must match the abutting sidewalk unless paved with pervious, porous, or permeable materials.
  - b). Stairs may be recessed into the building facade when the building is setback four (4) feet or less.
  - c). Stairs are not permitted to encroach onto any abutting sidewalk.
  - d). Stairs may be built perpendicular or parallel to the building facade, but must lead directly to ground level or an abutting sidewalk.

#### F. Portico

- i. A portico is a frontage type featuring a set of stairs with a landing leading to the entrance of a building and a roof supported by columns, piers, or posts.

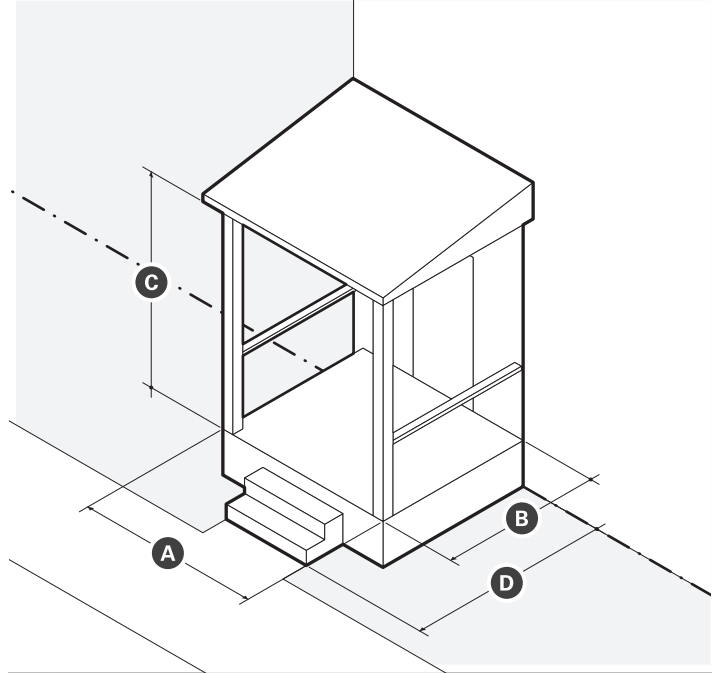

Dimensions	
<b>A</b> Landing Width (min)	4 ft
<b>B</b> Landing Depth (max)	4 ft
<b>C</b> Ceiling Height (max)	8 ft
<b>D</b> Permitted Front Setback Encroachment (max)	100%

- ii. Standards
  - a). Paving, excluding driveways, must match the abutting sidewalk unless paved with permeable paving.
  - b). Stairs are not permitted to encroach onto any abutting sidewalk.
  - c). Stairs may be built perpendicular or parallel to the building facade, but must lead directly to ground level or an abutting sidewalk.



## G. Projecting Porch

- i. A projecting porch is a frontage type featuring a set of stairs with a landing leading to the entrance of a building and a roof supported by columns, piers, or posts.

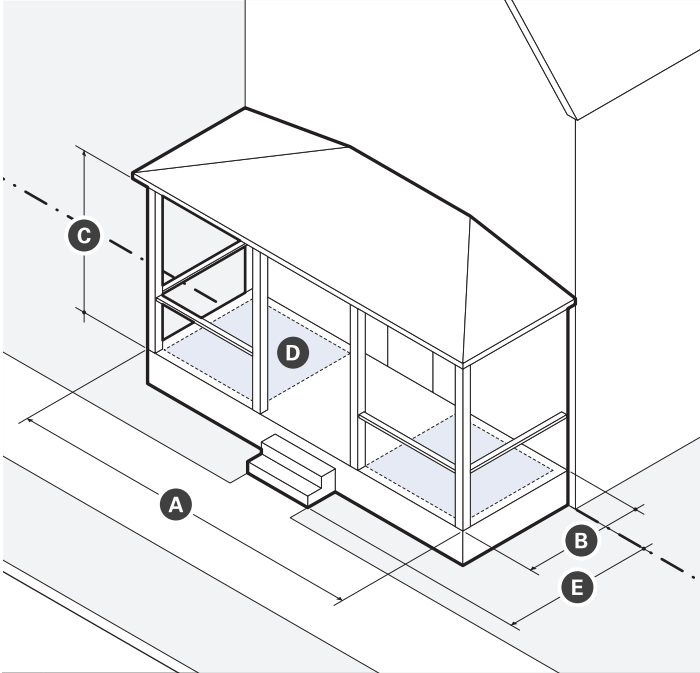

Dimensions	
<b>A</b> Width (min)	10' or 50% of facade width, whichever is greater
<b>B</b> Depth (min)	6 ft
<b>C</b> Ceiling Height (min)	8 ft
<b>D</b> Furniture Area, Clear (min)	6 ft x 6 ft
<b>E</b> Permitted Front Setback Encroachment (max)	10 ft

- ii. Standards
  - a). Paving, excluding driveways, must match the abutting sidewalk unless paved with permeable paving.
  - b). Stairs are not permitted to encroach onto any abutting sidewalk.
  - c). Porch railings must permit visual supervision of the public realm through the posts and rails.
  - d). A porch may be screened provided the percentage of window area to wall area is seventy percent (70%) or greater. Permanent enclosure of a porch to create year-round living space is not permitted.

## H. Dooryard

- i. A dooryard is a frontage type featuring fenced or elevated gardens or patios that buffer dwellings from an adjacent sidewalk.

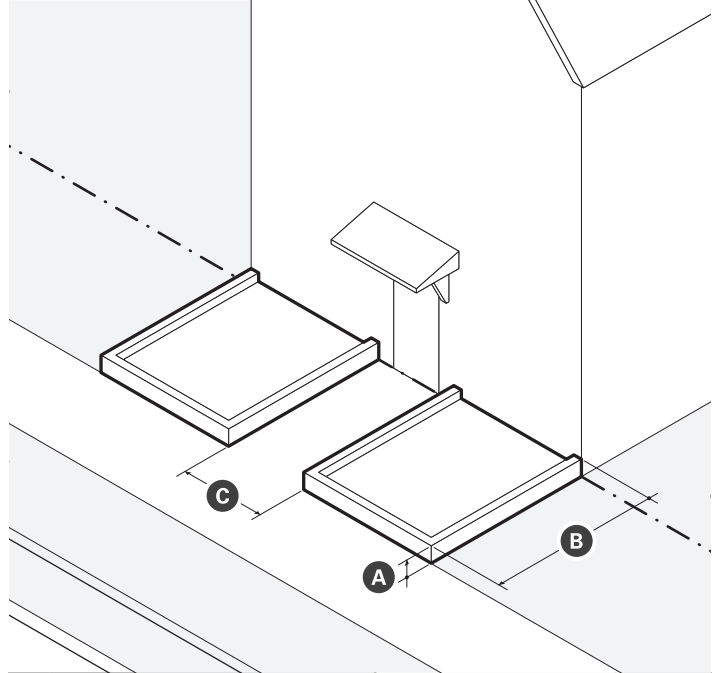

Dimensions	
Landscaped Area (min)	4 ft
<b>A</b> Elevation above Sidewalk (min)	18 in
<b>B</b> Depth (min)	100% of setback
<b>C</b> Path of Travel (min)	3 ft

- ii. Standards
  - a). Dooryards are an appropriate frontage type for a zero-step, accessible entrance, but may include steps leading to the entrance of the building.
  - b). Paving, excluding driveways, must match the abutting sidewalk unless paved with permeable paving.
  - c). A curb or retaining wall that is no taller than structurally necessary may be built around the planter, garden, terrace, or otherwise landscaped area.
  - d). Circulation between adjacent dooryards is prohibited.

# 3. RESIDENTIAL DISTRICTS

Urban Residence (UR)

## I. Forecourt

- i. A forecourt is a frontage type featuring a landscaped semi-public area, open to the sky, formed by a recess in a central portion of a buildings facade.

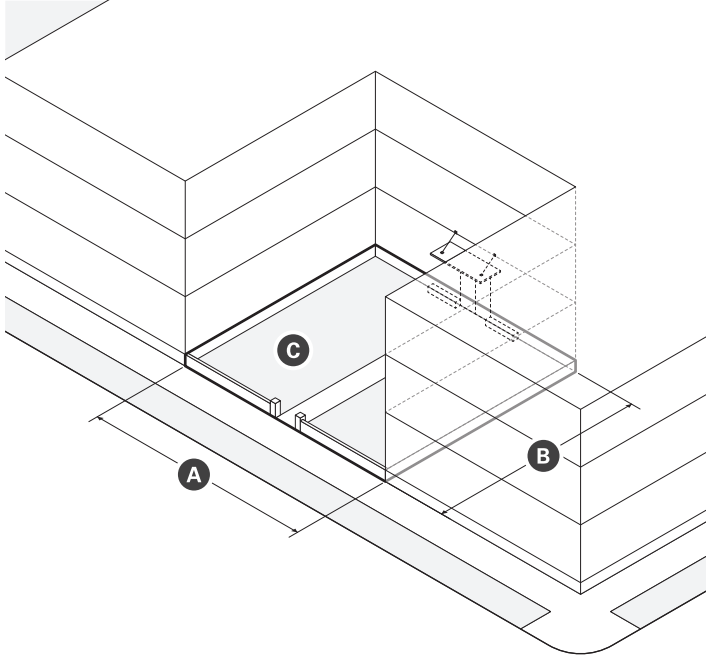

Dimensions	
<b>A</b> Width (min)	12 ft
<b>B</b> Depth (min)	12 ft
Height to Width Ratio (max)	2 to 1
<b>C</b> Landscaped Area (min)	30%

- ii. Standards
  - a). Paving, excluding driveways, must match the abutting sidewalk unless paved with permeable paving.
  - b). Forecourts are considered part of the building for the purpose of measuring facade build out.
  - c). A forecourt must be enclosed by walls on three sides.
  - d). Porches, stoops, porticos, entry canopies, and balconies may encroach into the forecourt.
  - e). Driveways, parking spaces, passenger drop-offs, garage entrances, loading and service areas, exhaust vents, mechanical equipment, and refuse or recycling storage are not permitted in forecourts.

## J. Lobby Entrance

- i. A lobby entrance frontage type featuring an at-grade principal entrance providing access to upper story uses of a building.

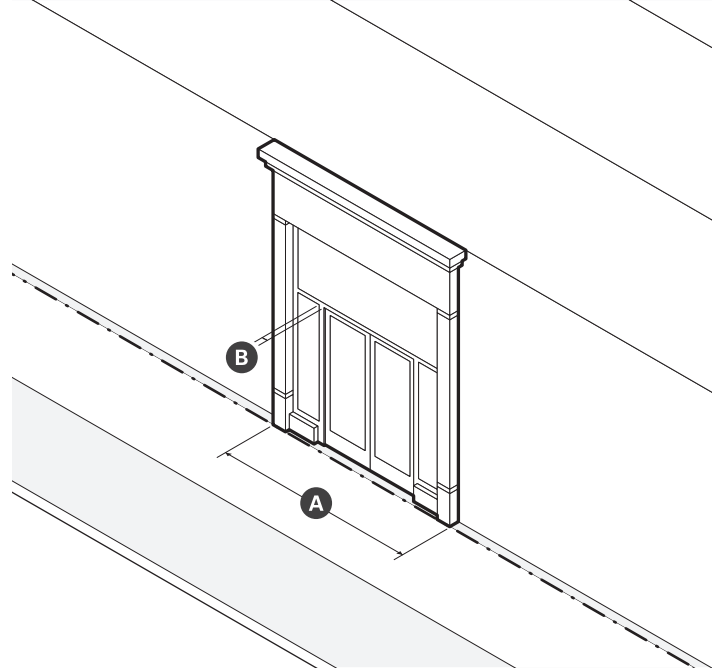

Dimensions	
<b>A</b> Width (max)	30 ft
<b>B</b> Distance between Fenestration (max)	2 ft
Depth of Recessed Entry (max)	5 ft

- ii. Standards
  - a). Lobby entrances must be well-defined, clearly visible, and universally accessible from the abutting sidewalk.
  - b). Lobby entrances should be made clearly identifiable using a difference in design from the rest of the facade.
  - c). Lobby entrances must include an awning or entry canopy above the principal entrance to provide weather protection.
  - d). When a lobby entrance is setback from the front lot line, the frontage must be paved to match the abutting sidewalk.

**K. Lightwell**

- i. A frontage type where the ground level is sunken to allow light and sometimes access into basement levels or to accommodate a change in grade at the front of a building.

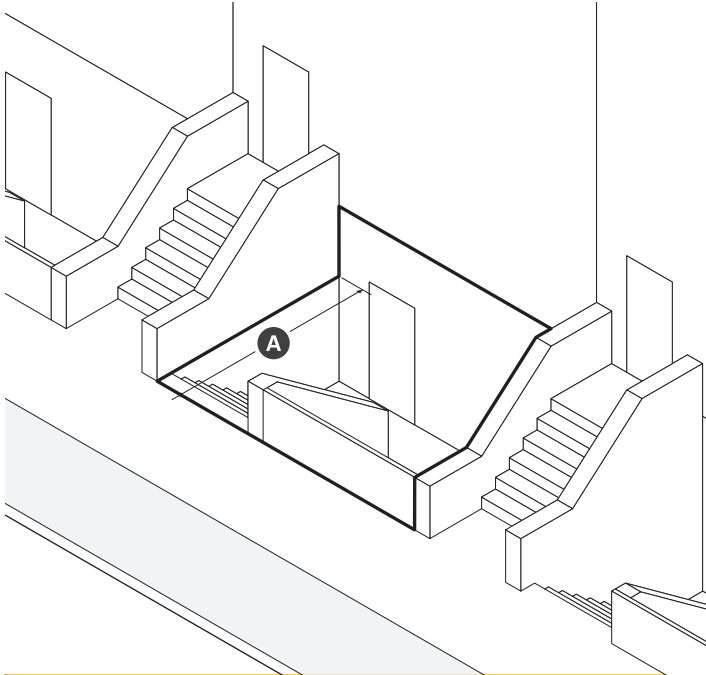

Dimensions	
<b>A</b> Depth (min)	5 ft
Fenestration (min)	--
Residential Uses	30%
Commercial Uses	50%

- ii. Standards
  - a). The principal entrance to upper stories must be provided at the ground story, rather than the basement.
  - b). An entrance to the basement is permitted on the below grade portion of the facade.
  - c). Below grade spaces are required to have windows and doors with highly transparent, low reflectivity glass.
  - d). A short fence is required at the front the sunken portion of the lot.

### 3. RESIDENTIAL DISTRICTS

Urban Residence (UR)

#### 15. Building Design Standards

- a. Contextual Front Setbacks
  - i. Notwithstanding the front setbacks identified for each building type, new construction must have a contextual front setback as follows:
    - a). If the subject lot is an interior lot or key lot, the minimum and maximum front setbacks are equal to the actual distances that principal structures are setback from the front lot line on the two abutting lots of the same block face. See Figure 3.1.
    - b). If the subject lot is a corner lot, the minimum front setback is equal to the actual distance that the principal structure is setback from the front lot line on the abutting lot that is oriented toward the same thoroughfare.
    - c). If the lot on either side of the subject lot is vacant, the minimum and maximum front setback identified for each building type governs.
  - ii. The contextual front setback provision does not exempt any building from complying with the maximum front setback required for each building type.

#### 16. Architectural Design Guidelines

- a. Residential Privacy
  - i. Ground story dwelling units should be elevated above the grade of any adjacent sidewalk so that the window sills of dwelling unit are at or above the eye-level of passing pedestrians. This elevation change maintains privacy for occupants while also encouraging open blinds or curtains to allow natural daylight into the unit.
  - ii. Fenestration patterns and window configurations that break the direct line of sight between residential uses on neighboring properties should be utilized to every extent possible. Translucent glass on the bottom half of windows or strategically placed landscape elements should be utilized if it is not practical to off-set windows in ways that minimize privacy impacts.
  - iii. Outdoor amenity spaces that are elevated such as roof decks, fully projecting balconies, and upper story rear porches should include screening walls or devices at the sides to provide privacy, security, and limit views of abutting properties from elevated vantage points.

FIGURE 3.1 (g) Contextual Front Setback

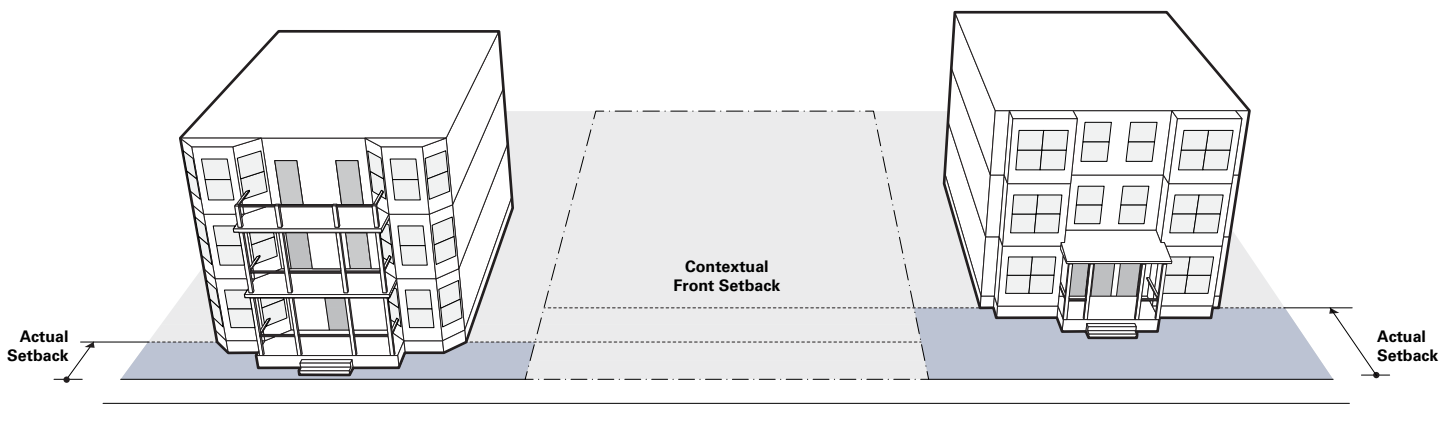

## 17. Use Provisions

- a. Permitted Uses
  - i. The use of real property is subject to the provisions of Article 9: Use Provisions of this Ordinance. Where the provisions of this section conflict with those of Article 9, the provisions of Article 9 apply.
  - ii. Uses are permitted as specified on Table 3.2 (c).
  - iii. Use categories not expressly authorized are prohibited.
  - iv. All uses must comply with any use-specific standards applicable for each use in §9.2 Use Definitions & Limitations.
  - v. Uses permitted by Special Permit require additional development review in accordance with §15.2.1 Special Permits.
- b. Adaptive Re-Use of Specific Buildings
  - i. The use of any principal structure constructed before the effective date of this Ordinance for a use that is considered nonconforming in the Urban Residential district, as established by permit records or other historical documents accepted by the Building Official, or any building used for municipal operations by the City of Somerville may be changed to any use within the following principal use categories in accordance with Table 3.2 (c):
    - a). Artisan Production;
    - b). Arts Sales & Services;
    - c). Design Services;
    - d). Shared Workspace & Arts Education;
    - e). Consumer Goods; or
    - f). Fresh Food Market or Grocery.
- c. Increases in Density
  - i. Existing structures may not be altered to conflict with number of dwelling units permitted for each building type.
  - ii. The alteration or renovation of an existing building that results in any increase of the number of dwelling units requires a special permit.
    - a). In its discretion to approve or deny a Special Permit authorizing an increase in the number of dwelling units in an existing building, the Review Board shall consider the following:
      - i). the review considerations for all Special Permits as specified in §15.2.1.e. Review Criteria; and
      - ii). the quality of the living space in terms of functional area.

Use Category Specific Use	UR	Use Specific Standards
<b>Arts &amp; Creative Enterprise</b>		
Artisan Production	SP	§3.1.15.b and §9.2.2.a
Arts Sales & Service	SP	§3.1.15.b and §9.2.2.c
Design Services	SP	§3.1.15.b and §9.2.2.d
Shared Workspace & Arts Education	SP	§3.1.15.b and §9.2.2.e
<b>Auto-Oriented</b>		
Motor Vehicle Parking (as noted below)	--	§9.2.3.d
Off-Site Accessory Parking	SP	§9.2.3.d.i
<b>Civic &amp; Institutional</b>		
Minor Utility Facility	SP	§9.2.4.d
Religious & Educational Uses Protected by M.G.L. 40A. Sec. 3	P	§9.2.4.h
<b>Commercial Services</b>		
Day Care Service (as noted below)	--	§9.2.5.h
Child Day Care Center	P	§9.2.5.h.ii
Vehicle Parking (except as follows)	N	§9.2.5.m
Bike Share Parking	P	§9.2.5.m.i

P - Permitted      SP - Special Permit Required      N - Not Permitted

### 3. RESIDENTIAL DISTRICTS

Urban Residence (UR)

**TABLE 3.3 (c) UR Permitted Uses (continued)**

Use Category Specific Use	NR	Use Specific Standards
Car Share Parking (3 or less spaces)	P	§9.2.5.m.ii
Car Share Parking (4 or more spaces)	SP	§9.2.5.m.ii
<b>Lodging</b>		
Bed & Breakfast	SP	§9.2.7.a
<b>Residential</b>		
Household Living	P	§9.2.9.a
Group Living (except as follows)	SP	§9.2.9.b
Community or Group Residence	P	§9.2.9.b.i
Dormitory, Fraternity, or Sorority	SP	§9.2.9.b.ii
Homeless Shelter	N	§9.2.9.b.iii
Nursing Home/Assisted Living Facility	SP	§9.2.9.b.iv
Rooming House	SP	§9.2.9.b.v
<b>Retail Sales</b>		
Consumer Goods (except as follows)	P	§3.1.15.b and §9.2.10.b
Alcohol Sales	N	§9.2.10.b.i
Drug Paraphernalia Store	N	§9.2.10.b.ii
Firearms Sales	N	§9.2.10.b.iii
Medical Marijuana	N	§9.2.10.b.iv
Pet Store	N	§9.2.10.b.v
Fresh Food Market or Grocery Store	P	§9.2.10.d
<b>Urban Agriculture</b>		
Farming (as noted below)	--	§9.2.11.a
Commercial Farm	N	§9.2.11.a.i
Community Farm	P	§9.2.11.a.ii
Community Gardening	P	§9.2.11.b
<b>Accessory Uses</b>		
Home Occupations (as noted below)	--	§9.2.12.b
Creative Studio	P	§9.2.12.b.i
Home-Based Business	P	§9.2.12.b.iii
Home Office	P	§9.2.12.b.v
Tourist Home	P	§9.2.12.c
Urban Agriculture (as noted below)	--	§9.2.12.d
Apiculture	P	§9.2.12.d.i
Aviculture	P	§9.2.12.d.ii
Commercial Farming	P	§9.2.12.d.iii
Residential Gardening	P	§9.2.12.d.iv
Vehicle Parking, Accessory (except as follows)	P	§9.2.12.e
Home Business Vehicle Parking	SP	§9.2.12.f

P - Permitted      SP - Special Permit Required      N - Not Permitted

### 3. RESIDENTIAL DISTRICTS

Urban Residence (UR)

#### 18. Vehicular Parking

- a. General
  - i. Vehicular parking must be provided as specified on Table 3.2 (d), except as follows:
    - a). Non-residential uses with five thousand (5,000) square feet or less of gross leasable floor area are exempt from the requirements of Table 3.2 (d).
  - ii. There are no parking requirements for accessory uses.
  - iii. Parking may be shared between uses on the same lot and buildings on the same block in accordance with §12.3 Shared Parking.
  - iv. One (1) on street parking space for every twenty (20) feet of lot width may be counted toward any parking requirement if residential permit parking is permitted along the same side of the street as the lot that the spaces will serve.
- b. Type
  - i. Motor vehicle parking may be provided as surface parking spaces, above ground structured parking, underground structured parking, and on street parking spaces.
- c. Unbundled Parking
  - i. Motor vehicle parking spaces must be rented or leased as an option rather than a requirement of the rental, lease, or purchase of a dwelling unit or non-residential floor space.
- d. Parking Location
  - i. Required vehicular parking, excluding any required handicapped parking, may be provided on a contiguous lot under the same ownership as the lot that the parking will serve according to the following:
    - a). Pedestrian access to off-site vehicular parking must be via a paved sidewalk or walkway.
    - b). A lease, recorded covenant, or other comparable legal instrument guaranteeing long term use of the site must be provided to the review board or building official and executed and filed with the Registry of Deeds.
  - ii. For real property located in more than one municipality, motor vehicle parking need not be located within the City of Somerville.
- e. Parking Relief
  - i. Relief from the parking standards of Table 3.2 (d) requires a Special Permit.
    - a). In its discretion to approve or deny a special

**TABLE 3.2 (d) UR Parking**

\*See Transit Areas Map

Use Category Specific Use	BICYCLE		MOTOR VEHICLE	
	Short-Term (min)	Long-Term (min)	Within a Transit Area* (max)	Outside of a Transit Area* (min)
<b>Arts &amp; Creative Enterprise</b>				
Artisan Production	1.0 / 10,000 sf	1.0 / 3,000 sf	n/a	1.0 / 1,000 sf
Arts Sales & Service	1.0 / 10,000 sf	1.0 / 3,000 sf	n/a	1.0 / 1,000 sf
Design Services	1.0 / 10,000 sf	1.0 / 3,000 sf	n/a	1.0 / 1,000 sf
Shared Workspace & Arts Education	1.0 / 10,000 sf	1.0 / 3,000 sf	n/a	1.0 / 650 sf
<b>Lodging</b>				
Bed & Breakfast	1.0 / 20 rooms	1.0 / 10 rooms	n/a	1 / 4 rooms
Short Term Rental	1.0 / 20 rooms	1.0 / 10 rooms	n/a	1 / DU
<b>Residential</b>				
Household Living	n/a	n/a	n/a	1 / DU
Group Living	n/a	n/a	n/a	1 / DU
<b>Retail Sales</b>				
Consumer Goods	1.0 / 2,500 sf	1.0 / 10,000 sf	n/a	1 / 1,500 sf
Fresh Food Market or Grocery Store	1.0 / 2,500 sf	1.0 / 10,000 sf	n/a	1 / 1,500 sf

sf - Gross Leasable Square Footage

DU - Dwelling Unit

RU - Rooming Unit

### 3. RESIDENTIAL DISTRICTS

#### Urban Residence (UR)

permit authorizing relief from the parking standards of Table 3.2 (d), the review board shall consider the following:

- i). The supply and demand of on-street parking in the neighborhood, as determined through a parking study.
- ii). Mobility management programs and services provided by the applicant to reduce the demand for parking.
- iii). That parking provided in excess of any maximum permitted does not result in the increase in impervious lot area.

#### 19. Site Development

##### a. General

- i. Development is subject the provisions of Article 10: Site Development Standards of this Ordinance. Where the provisions of this section conflict with those of Article 10, the provisions of Article 10 apply.

##### b. Parking Design

###### i. General

- a). Bicycle and motor vehicle parking is subject to §12.1 Parking Design of this Ordinance.

###### ii. Access

- a). Driveways, curb cuts, and vehicular entrances to parking lots, parking structures, loading docks, and service areas are not permitted along primary front lot lines abutting a pedestrian street, but may provide access from a side street or alley.

###### iii. Driveways

- a). Driveways may be located within a required side and rear setback areas, but are not permitted between the facade of a building and any front lot line.
- b). Driveways may be no more than twelve (12) feet in width at the frontage.
- c). Driveways may provide access in whole or in part on or across an abutting lot(s), provided that an access easement exists between all property owners.

###### iv. Curb Cuts

- a). Unless otherwise specified, only one (1) curb cut is permitted per front lot line.
- b). Curb cuts must be located to minimize conflict with pedestrians, bicyclists, and motor vehicles on the thoroughfare they provide access to and from.
- c). Curb cuts may be no wider than the driveway or vehicular entrance they serve, excluding flares or returned curbs.

###### v. Driveway and Alley Crossings

- a). Driveway crossings traversing sidewalks with

paved furnishing zones must be designed to maintain the grade and clear width of the walkway they cross and must include sloped flares on either side of the driveway apron.

- b). Driveway crossings traversing sidewalks with continuously planted furnishing zones must be designed to maintain the grade and clear width of the walkway they cross and must include returned curbs.

- c). The appearance of any walkway (ie. scoring pattern or special paving) must be maintained across any driveway or alley to indicate that, although a vehicle may cross, the area traversed by a vehicle remains part of the sidewalk.

##### c. Signs

- i. A sign, individual numerals or letters, or a nonelectrical nameplate identifying the property address is required for all real property as follows:
  - a). Each ground story non-residential use must identify the street address either on the principal entrance door or above or beside the principal entrance of the use.
  - b). All residential building types must identify the street address either on the principal entrance door, above or beside the principal entrance, or on a mailbox.
- ii. Address signs must be made easily visible through the use of colors or materials that contrast with the background material they are attached to and must be conspicuously located to provide visibility from the thoroughfare that the building faces.
- iii. Address signs must be twelve (12) inches in height or less and may include the name of the occupant.